



# STi7110FTA

## HDTV satellite set-top box decoder for Microsoft VC-1, H.264 and MPEG-2

Data brief

### Features

- STi7110FTA is a unique predefined profile (no possible variant) with Dolby enabled (Dolby license required)
- Microsoft VC-1, MPEG-2 and H.264 support
- ST40-300 CPU, high performance for Linux- and OS21-based systems
- DVB-S2 and DVB-S front-end integrated demodulators with fully featured HD advanced decoder SoC
- Flexible ST231-based advanced video decoder
- Advanced multi-channel audio decoding (WMA9, AC3, DD+, AAC, AAC+ with SPDIF output)
- Advanced high-definition video decoding
- Advanced standard-definition video decoding
- HDMI/HDCP output plus HD or SD component and composite output
- Unified DDR2 32-bit interface
- Programmable transport interface (PTI) and transport stream (TS) merger
- USB 2.0 to support network interface and feature enhancement
- External memory interface (EMI) with NAND-Flash, NOR-Flash, PCI, peripherals support
- Ethernet MAC with media independent interface (MII) and reduced MII (RMII)
- Dual smartcard, five UARTs, three external synchronous serial controllers (SSCs), soft modem and DAA interface, IR blaster and receiver, UHF Rx digital input
- DiSEqC 2.0 and FSK modem supported
- 4 x 4 matrix key front panel switch scanner FSM with key de-bounce
- 27 mm x 27 mm package

### Description

The STi7110FTA is an HD set-top box that provides very high performance for low-cost HD systems. The STi7110FTA presents a new generation of HD video decoders for VC-1 Microsoft video (including Windows Media Video 9) as well as H.264 (MPEG-4 part 10) and MPEG-2 HD demodulating and decoding.

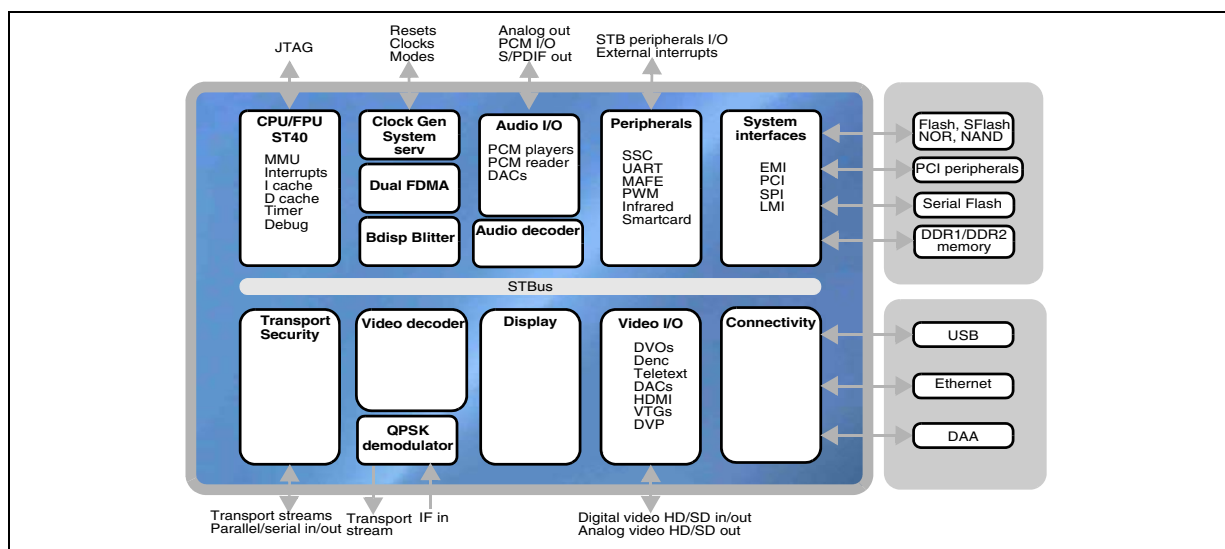

# 1 Introduction

The STi7110FTA uses ST's state-of-the-art process technology to provide a low-cost, full-featured advanced decoding HD set-top box SoC. It is a highly integrated solution suitable for DVB-S2 and DVB-S set-top box markets worldwide.

The STi7110FTA provides a solution for operators to specify a range of low-cost HD STBs including low-cost DVB-S2 Zappers, interactive STBs and DVR capable STBs. The STi7110FTA is optimized for IP-TV and home networking applications with integrated DVB, DES, AES and Multi2 descramblers and smartcard interfaces. The STi7110FTA offers enhancements in performance, features and integration to current users of ST's HD AVC family of audio/video decoders, whilst reducing cost and time-to-market for the next generation of deployments.

Features	Benefits
Combines a QPSK demodulator with STB decoding and display functions	This highly integrated SoC helps to reduce board area and manufacturing cost, allowing low-cost and small size STBs to be designed.
ST40-300 applications CPU, 32K I cache, 32K D cache	Superscalar performance from a single CPU core, using standard tools and operating systems (Linux, OS21).
STMicroelectronics' video decoding system	Decoding of advanced high-definition standards for MPEG2, H264, VC-1 broadcast, with the performance and flexibility for web-based content decoding such as Flash, DivX, MJPEG and Real.
USB 2.0 hosts, Ethernet MAC with MII/RMII and TMII, interfaces, PCI interface	Extensive high-speed connectivity for the widest range of STB peripherals, such as Flash drives, external HDDs, home network controllers (for example MoCA, Wi-Fi), DOCSIS modem and so on.
Low-power process, design and architecture	Best in class, low-power standby mode, to meet emerging energy standards for STBs. Dynamic configuration of power to individual subsystems enables power-efficient active standby modes.
Advanced 2D graphics and display subsystem	Allows visually appealing user interfaces and video rich navigation to be offered to consumers, while high-quality progressive output can be watched on the latest high-definition displays.

## 2 Revision history

Table 1. Document revision history

Date	Revision	Changes
20-Oct-2010	1	Initial release.

**Please Read Carefully:**

Information in this document is provided solely in connection with ST products. STMicroelectronics NV and its subsidiaries ("ST") reserve the right to make changes, corrections, modifications or improvements, to this document, and the products and services described herein at any time, without notice.

All ST products are sold pursuant to ST's terms and conditions of sale.

Purchasers are solely responsible for the choice, selection and use of the ST products and services described herein, and ST assumes no liability whatsoever relating to the choice, selection or use of the ST products and services described herein.

No license, express or implied, by estoppel or otherwise, to any intellectual property rights is granted under this document. If any part of this document refers to any third party products or services it shall not be deemed a license grant by ST for the use of such third party products or services, or any intellectual property contained therein or considered as a warranty covering the use in any manner whatsoever of such third party products or services or any intellectual property contained therein.

**UNLESS OTHERWISE SET FORTH IN ST'S TERMS AND CONDITIONS OF SALE ST DISCLAIMS ANY EXPRESS OR IMPLIED WARRANTY WITH RESPECT TO THE USE AND/OR SALE OF ST PRODUCTS INCLUDING WITHOUT LIMITATION IMPLIED WARRANTIES OF MERCHANTABILITY, FITNESS FOR A PARTICULAR PURPOSE (AND THEIR EQUIVALENTS UNDER THE LAWS OF ANY JURISDICTION), OR INFRINGEMENT OF ANY PATENT, COPYRIGHT OR OTHER INTELLECTUAL PROPERTY RIGHT.**

**UNLESS EXPRESSLY APPROVED IN WRITING BY AN AUTHORIZED ST REPRESENTATIVE, ST PRODUCTS ARE NOT RECOMMENDED, AUTHORIZED OR WARRANTED FOR USE IN MILITARY, AIR CRAFT, SPACE, LIFE SAVING, OR LIFE SUSTAINING APPLICATIONS, NOR IN PRODUCTS OR SYSTEMS WHERE FAILURE OR MALFUNCTION MAY RESULT IN PERSONAL INJURY, DEATH, OR SEVERE PROPERTY OR ENVIRONMENTAL DAMAGE. ST PRODUCTS WHICH ARE NOT SPECIFIED AS "AUTOMOTIVE GRADE" MAY ONLY BE USED IN AUTOMOTIVE APPLICATIONS AT USER'S OWN RISK.**

Resale of ST products with provisions different from the statements and/or technical features set forth in this document shall immediately void any warranty granted by ST for the ST product or service described herein and shall not create or extend in any manner whatsoever, any liability of ST.

ST and the ST logo are trademarks or registered trademarks of ST in various countries.

Information in this document supersedes and replaces all information previously supplied.

The ST logo is a registered trademark of STMicroelectronics. All other names are the property of their respective owners.

© 2010 STMicroelectronics - All rights reserved

STMicroelectronics group of companies

Australia - Belgium - Brazil - Canada - China - Czech Republic - Finland - France - Germany - Hong Kong - India - Israel - Italy - Japan - Malaysia - Malta - Morocco - Philippines - Singapore - Spain - Sweden - Switzerland - United Kingdom - United States of America

[www.st.com](http://www.st.com)