

Antenna tuning circuit with turbo and glide

Datasheet - production data

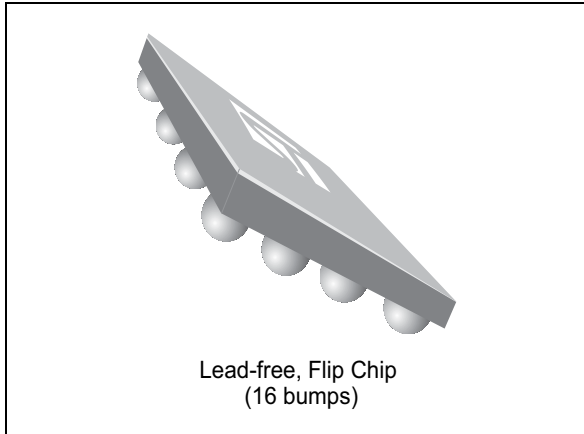

Description

The ST high voltage BST capacitor controller STHVDAC-253MTG is a high voltage digital to analog converter (DAC), specifically designed to control and meet the wide tuning bias voltage requirement of the BST tunable capacitors.

It provides 3 independent high voltage outputs, thus having the capability to control 3 different capacitors. It is fully controlled through an RFFE serial interface.

BST capacitors are tunable capacitors intended for use in mobile phone application, and dedicated to RF tunable application. These tunable capacitors are controlled through a bias voltage ranging from 0 to 24 V. The implementation of BST tunable capacitor in mobile phones enables significant improvement in term of radiated performance, making the performance almost insensitive to external environment.

Features

- Dedicated controller to bias BST tunable capacitors
- Operation compliant with cellular systems requirements
- Turbo and glide modes for optimal system performance
- Integrated boost converter with 3 programmable outputs (from 0 to 24 V)
- Low power consumption
- MIPI RFFE serial interface 1,8 V
- Available in WLCSP for stand-alone or SiP module integration

Applications

- Cellular antenna tunable matching network in multi-band GSM/WCDMA/LTE handsets
- Compatible for open loop antenna tuner application

Benefits

RF tunable passive implementation in mobile phones to optimize the radiated performance.

Figure 1. Pin configuration (top view)

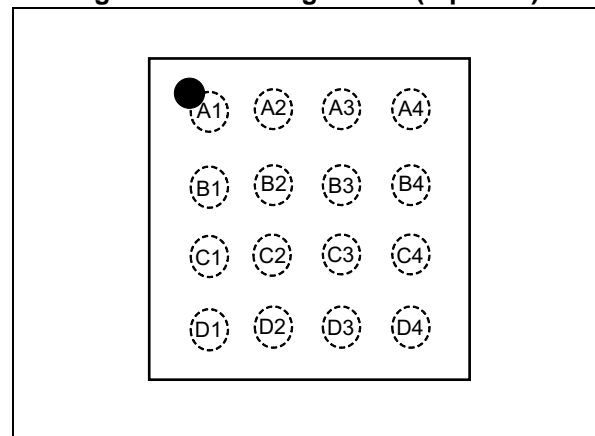

1 Electrical characteristics

Table 1. Absolute maximum ratings (limiting value)

| Symbol | Parameter | Rating | Unit |
|-----------------|---|-------------------------|------|
| V_{DD} | Analog supply voltage | -0.3 to +5.5 | V |
| $V_{I/O}$ | Digital supply voltage | -0.3 to +3.3 | V |
| V_{LOG} | Input voltage logic lines (DATA, CLK, SEL_ID0, SEL_ID1) | -0.5 to $V_{I/O} + 0.5$ | V |
| $V_{ESD (HBM)}$ | Human body model, JESD22-A114-B, All I/O | 2 | kV |
| T_{stg} | Storage temperature | -55 to +150 | °C |
| T_j | Maximum junction temperature | 150 | °C |

Table 2. Recommended operating conditions

| Symbol | Parameter | Rating | | | Unit |
|---------------|--|---------------------|------|---------------------|------|
| | | min. | typ. | max. | |
| T_{AMB_OP} | Operating ambient temperature | -30 | - | +85 | °C |
| V_{DD} | Analog supply voltage | 2.3 | - | 5 | V |
| $V_{I/O}$ | Digital supply voltage | 1.65 | - | 1.95 | V |
| V_{IH} | Input voltage logic level High (DATA, CLK, SEL_ID0, SEL_ID1) | $0.7 \cdot V_{I/O}$ | - | $V_{I/O} + 0.3$ | V |
| V_{IL} | Input voltage logic level Low (DATA, CLK, SEL_ID0, SEL_ID1) | -0.3 | - | $0.3 \cdot V_{I/O}$ | V |

Table 3. DC characteristics

| Conditions: AV _{DD} 3.3V, VI/O from 1.65 to 1.95V, T _{amb} from -30 °C to +85 °C, L _{BOOST} = 15 μH unless otherwise specified | | | | | | | |
|---|--|--|--|-------------------|-------------------|------|------|
| Symbol | Parameter | Conditions | Min. | Typ. | Max. | Unit | |
| I _{LBOOST} | Boost inductor supply current L=15μH, AV _{DD} =3.3V | Low Power mode or shutdown | | 0.28 | 1 | μA | |
| | | I _{LBOOST_SS2} | Active mode, 1 output steady state 2V | | 130 | | |
| | | | Active mode, 3 outputs steady state 2V | | 310 | | 700 |
| | | I _{LBOOST_SS20} | Active mode, 1 output steady state 20V | | 150 | | |
| Active mode, 3 outputs steady state 20V | | | 380 | 800 | | | |
| I _{AVDD} | AVDD supply current AVDD=3.3V | Low Power mode or shutdown | | 1.55 | 5 | μA | |
| | | I _{AVDDT_SS2} | Active mode, 1 output steady state 2V | | 600 | | |
| | | | Active mode, 3 outputs steady state 2V | | 720 | | 1200 |
| | | I _{AVDD_SS20} | Active mode, 1 output steady state 20V | | 600 | | |
| Active mode, 3 outputs steady state 20V | | | 700 | 1200 | | | |
| I _{I/O} | V _{I/O} supply current | Low Power mode or shutdown | | 1.8 | 5 | μA | |
| | | Active mode: (3 outputs active) No activity on CLK, VI/O=1.8V FCLK = 13MHz FCLK = 26MHz | | 28 560 1100 | 50 800 1500 | μA | |
| I _{IH} | Input current logic level high | Any mode, DATA, CLK, SEL_ID0, SEL_ID1 pins | -1 | | +1 | μA | |
| I _{IL} | Input current logic level low | Any mode, DATA, CLK, SEL_ID0, SEL_ID1 pins | -1 | | +1 | μA | |
| V _{IORST} | VIO low threshold | | | | 0.5 | V | |

Table 4. High voltage DAC output characteristics

| Conditions: AV _{DD} from 2.3 to 5V, VI/O from 1.65 to 1.95 V, T _{amb} from -30 °C to +85 °C, OUTA-C, unless otherwise specified | | | | | | |
|---|----------------------------------|-------------------------------------|-------|-------|------|--------------------|
| Symbol | Parameter | Conditions | Min. | Typ. | Max. | Unit |
| LOW POWER MODE | | | | | | |
| Z _{out} | OUTA-OUTC output impedance | | 6 | | | MΩ |
| ACTIVE MODE | | | | | | |
| V _{OH} | OUTA-OUTC maximum output voltage | DAC = 7Fh, I _{LOAD} < 1 μA | 23.17 | 23.88 | | V |
| V _{OL} | OUTA-OUTC minimum output voltage | DAC = 0Ah, I _{LOAD} < 1 μA | | 1.88 | 1.94 | V |
| Resolution | Voltage resolution / OUTA- OUTC | 7 bits DAC, 01h to 7Fh range | | 188 | | mV |
| INL | Integral Non Linearity | DAC A – DAC C from 0Ah to 7Fh | -3 | | +3 | LSB |
| DNL | Differential non Linearity | DAC A – DAC C from 0Ah to 7Fh | -0.5 | | +0.5 | LSB |
| Error | DACs error | DAC A – DAC C from 0Ah to 7Fh | -3 | | +3 | % V _{out} |
| Isc | Over Current Protection | Any DAC output | | | 50 | mA |

2 Functional block diagram

Figure 2. HV DAC functional block diagram

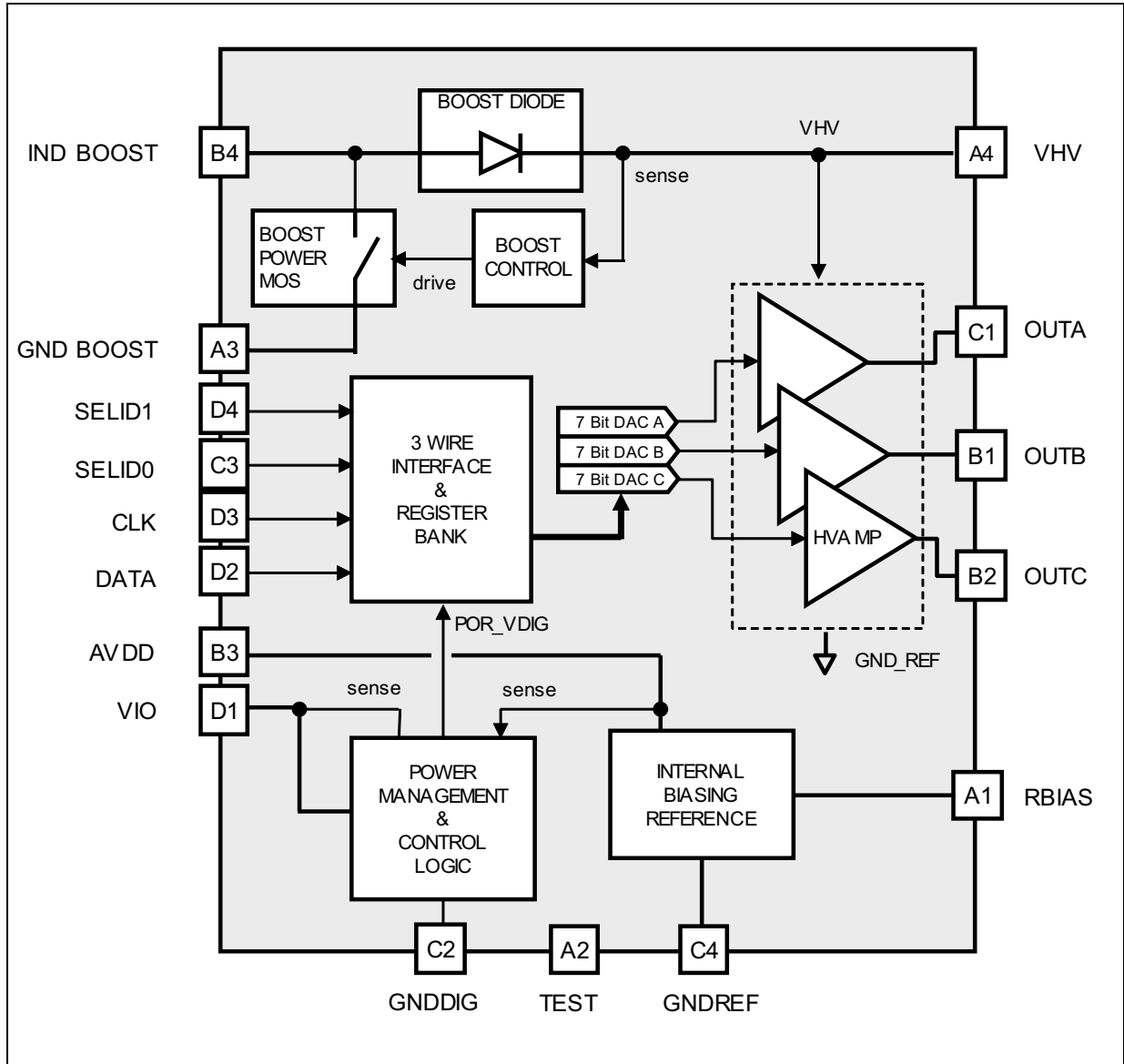

Table 5. Signals description

| Pin number | Pin name | Description |
|------------|-----------|---|
| A1 | RBIAS | Biasing reference resistance |
| A2 | TEST | Reserved for test, leave unconnected in application PCB |
| A3 | GND_BOOST | Power Ground |
| A4 | VHV | Boost High voltage output |
| B1 | OUTB | High voltage output B |
| B2 | OUTC | High voltage output C |
| B3 | AVDD | Analog supply |
| B4 | IND_BOOST | Boost inductance |
| C1 | OUTA | High voltage output A |
| C2 | GNDDIG | Digital Ground |
| C3 | SELID0 | RFFE interface / SELID0 |
| C4 | GND_REF | Reference Ground |
| D1 | VIO | IO supply voltage |
| D2 | DATA | RFFE interface / Serial Data |
| D3 | CLK | RFFE interface / Serial Clock |
| D4 | SELID1 | RFFE interface / SELID1 |

3 Theory of operation

3.1 HVDAC output voltages

The HVDAC outputs are directly controlled by programming the 7 bits DAC (DAC A to DAC C) through the RFFE interface.

The DAC stages are driven from a reference voltage, generating an analog output voltage driving a high voltage amplifier supplied from the boost converter (see HVDAC block diagram [Figure 2](#)).

The HVDAC output voltages are scaled from 0 to 24 V, with 127 steps of 188 mV. If DAC value is set to 00h, then the corresponding output is setup to be in high impedance state (6 MΩ).

STHVDAC-253MTG has been specifically designed to drive BST tunable capacitors, equivalent to RC output loads as shown in [Figure 3](#).

Figure 3. HVDAC output load

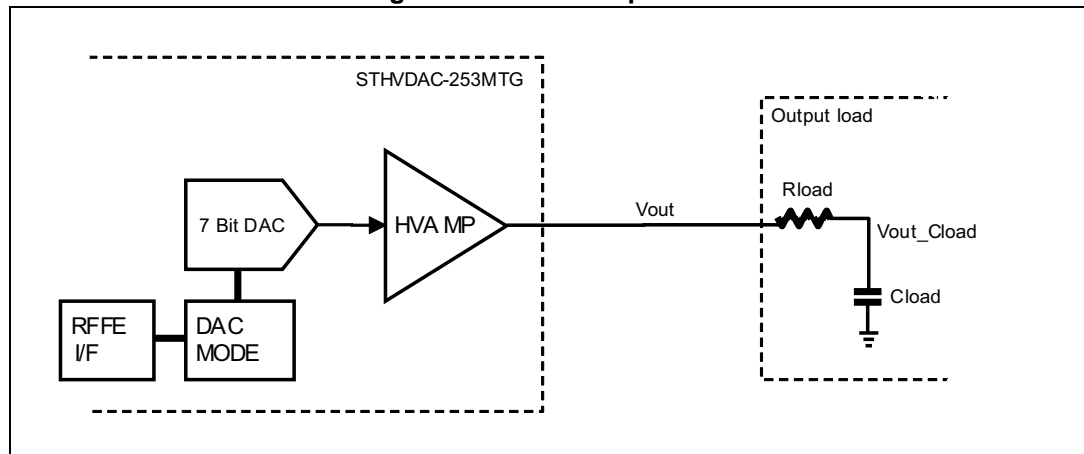

Each DAC output can be operated either in normal, turbo or glide mode. The DAC mode is set by controlling turbo mode bit of each DAC register (MSB of registers 2, 3, 4, 6, 7, 8), and Glide_enable bits (defined in registers#1 and 5).

3.1.1 DAC operation in normal mode -- glide_enable = 0b, turbo_mode = 0b

In normal mode, the DAC output directly switches from old to new output voltage after programming. The DAC output is controlled to ensure the output voltage (V_{out} , see [Figure 3](#)) reaches its final value within 10μs typical after valid RFFE command.

Typical timing diagram in Normal mode is shown on [Figure 4](#).

3.1.2 DAC operation in turbo mode -- glide_enable = 0b, turbo_mode = 1b

A specific turbo mode is implemented in the STHVDAC-253MTG to ensure a fast system settling time.

In this mode, the DAC voltage outputs are optimized to minimize the settling time on the output capacitor load (V_{out_Cload} , see [Figure 3](#)). Once enabled, the output voltage on the output capacitor reaches its final value within 55µs typical.

In turbo mode, STHVDAC-253MTG has been optimized to support up to 4 different output RC loads, as defined in [Table 6](#). The RC loads can be selected for each output independently, by controlling PTIC_selection bits in registers#9 to 11.

Typical timing diagram in turbo mode is shown on [Figure 4](#).

3.1.3 DAC operation in glide mode - glide_enable = 1b, turbo_mode = x

Glide mode has been implemented to smooth DAC output voltage transition, and to minimize the impact of tunable capacitor changes on RF system performance (especially to meet 3GPP phase discontinuity requirements).

In this mode, the DAC output voltage transitions from old to new voltage value, in a period of time equal to the glide_delay defined as :

Glide_delay = glide_step_delay * 256 (programmable from 512 µs up to 16.84 ms)

glide_step_delay defined in registers#1 and 5 as per [Table 11](#).

Typical timing diagram in glide mode is shown on [Figure 4](#).

Table 6. Supported output RC loads (turbo mode only)

| PTIC_selection bits | | Rload | Cload |
|---------------------|---|-------|--------|
| 0 | 0 | 12 kΩ | 2.7 nF |
| 0 | 1 | 17 kΩ | 2.7 nF |
| 1 | 0 | 22 kΩ | 2.7 nF |
| 1 | 1 | 27 kΩ | 2.7 nF |

Figure 4. HVDAC output voltage in normal, turbo and glide modes

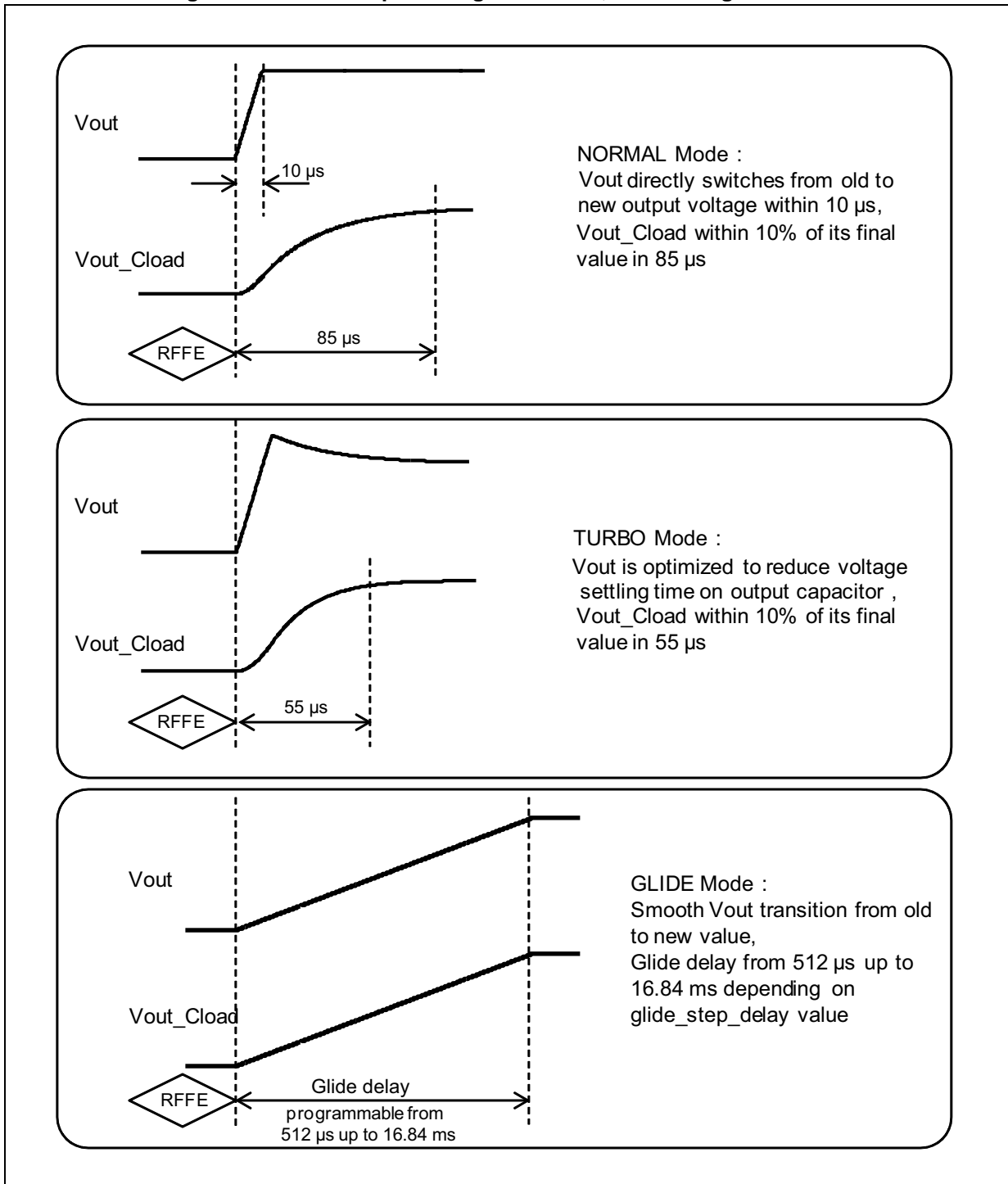

4 Devices operating modes

The following operating modes are accessible through the serial interface:

4.1 Shutdown mode:

The HVDAC is switched OFF, and all the blocks in the control ASIC are switched OFF. Power consumption is almost zero in this mode, the DAC outputs are in high Z state. The shutdown mode is set by driving VIO to LOW level.

4.2 Active mode:

The device is directly set into this mode after startup, or by driving PWR_MODE bits to 00b in register #0 or 28#.

Active mode is further controlled through reg0 bit D5:

D5 = 0b (default) : Idle mode

the device is switched OFF except the RFFE interface. Power consumption is almost zero in this mode, the DAC outputs are in high Z state. (same as Low power mode)

D5 = 1b : Operating mode :

The HVDAC is switched ON and the DAC outputs are fully controlled through the RFFE serial interface. The DAC settings can be dynamically modified and the outputs will be adjusted according to the specified timing diagrams. Each DAC can be individually controlled and/or pulled down according to application requirements.

4.3 Low power mode:

The HVDAC is switched OFF except the RFFE interface. Power consumption is almost zero in this mode, the DAC outputs are in high Z state.

The device is set into this mode by driving PWR_MODE bits to 10b. All registers can be controlled and accessed in low power mode.

Figure 5. HVDAC state diagram

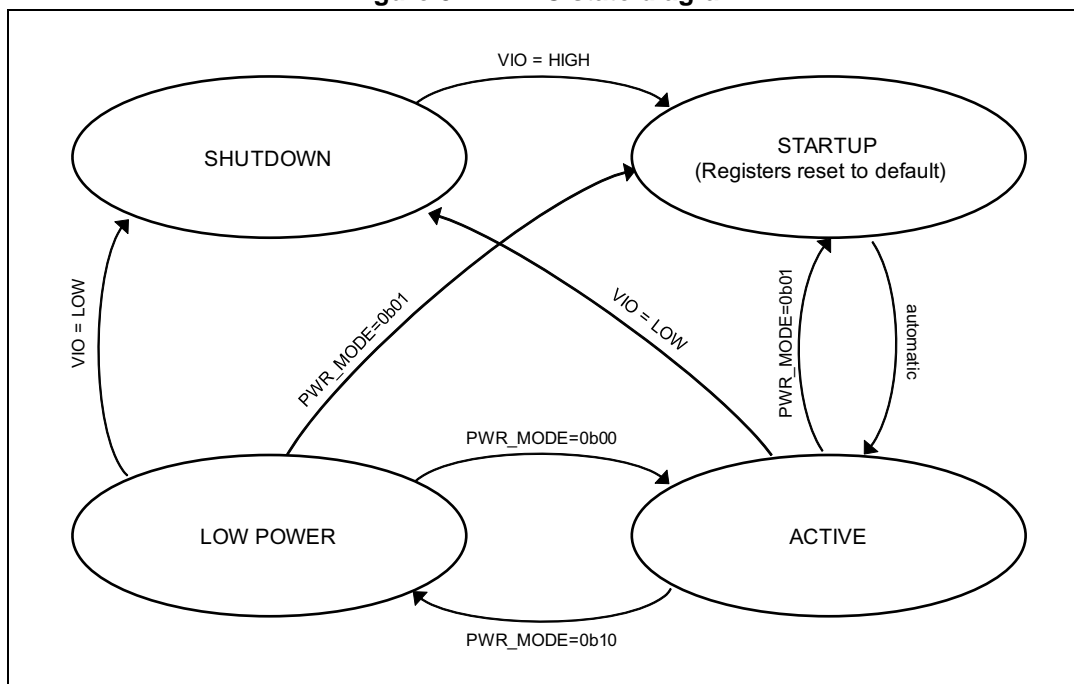

4.4 Device reset

Power-On Reset is implemented on the VI/O supply input, ensuring the HVDAC will be reset to default mode once VI/O supply line rises above a given threshold (typically 1V). This trigger will force all registers to their default value.

Device Reset is also implemented as defined in the MIPI RFFE specification. Setting PWR_MODE bits to 01b will force the device to reset all registers to their default value, and then automatically switch the device into low power mode.

A Soft Reset is implemented using register #26 MSB. Setting this bit will reset all registers to their default values, except PM_TRIG register (reg #28) and device USID (reg #31).

4.5 RFFE serial interface

The HVDAC is fully controlled through RFFE serial interface (DATA, VIO, CLOCK).

This interface is further described in the next sections of this document and is made compliant to the MIPI Alliance Specification for RF Front End control Interface version 1.10 - 26 July 2011 (see [Figure 12](#) and [Figure 13](#)).

Sequence Start Condition (SSC): One rising edge followed by falling edge on DATA while CLK remains at logic level low. This is used by the Master to identify the start of a Command frame.

Parity (P): Each frame shall end with a single parity bit. The parity bit shall be driven such that the total number of bits in the frame that are driven to logic level one, including the parity bit, is odd.

Bus park cycle (BP): The slave releasing DATA will drive the DATA to logic level zero during the first half of the CLK clock cycle. This is used by the master as the indication of the end of Frame.

4.6 RFFE serial interface extended mode

All the registers in the device can be addressed in extended mode, by sending appropriate command sequences as per MIPI RFFE specification (see [Figure 14](#)).

4.7 RFFE serial interface broadcast capability

Registers#28 to 31 can be addressed in broadcast mode, by sending appropriate command sequences as per MIPI RFFE specification.

4.8 RFFE interface - command and data frame structure

The STHVDAC-253MTG RFFE interface has been implemented to support the following command sequences :

- Register WRITE
- Register READ
- Extended register write

These supported command sequences are described in [Figure 6](#).

Figure 6. Supported command sequences

| | SSC | | | Command Frame | | | | | Data frame | | | | | | | | | | | | | | | | | | | | |
|-------------------------|-----|---|---|---------------|---|---|---|------------------|------------|-----------|-----------|---|--------------|--|--|--|---|----|----|---|-----------------------------------|--|--|--|--|--|----|--|--|
| Register WRITE | 0 | 1 | 0 | USID | 0 | 1 | 0 | REG Address[4,0] | P | DATA[7,0] | | | | | | | P | BP | | | | | | | | | | | |
| Register READ | 0 | 1 | 0 | USID | 0 | 1 | 1 | REG Address[4,0] | P | BP | DATA[7,0] | | | | | | | P | BP | | | | | | | | | | |
| Extended Register WRITE | 0 | 1 | 0 | USID | 0 | 0 | 0 | 0 | 0 | 0 | 0 | P | Address[7,0] | | | | | | | P | Up to 4 bytes of data with parity | | | | | | BP | | |
| | | | | | | | | BC[3,0] | | | | | | | | | | | | | | | | | | | | | |
| | | | | | | | | 1 | 1 | 1 | 1 | | | | | | | | | | | | | | | | | | |

USID : Unique Slave Identifier
 SSC : Sequence Start Condition
 P : Parity Bit
 BC : Byte Count
 BP : Bus Park Cycle

All frames are required to end with a single parity bit. The parity bit shall be driven such that the total number of bits in the frame that are driven to logic level 1, including the parity bit, is odd. In case the device detects a parity error, the frame is considered not valid and is ignored.

4.9 Power-up/down sequence

[Table 7](#) and [Figure 8](#) are describing the HVDAC settling time requirements and recommended timing diagrams.

Switching from Shutdown to Active mode is triggered by setting VIO to HIGH level.

Switching from Low Power to Active mode will occur setting PWR_MODE bits to 00b (REGISTER#28 or REGISTER#0).

Switching from active to low power mode will occur setting PWR_MODE bits to 10b (REGISTER#28 or REGISTER#0).



Following active mode command (from Low power), the HVDAC will be operational after t_{active} (typ. 100 μs). Once in active mode, a settling time of 10 μs typ (Tset) is required following each DAC command in active mode. During this settling time the HVDAC output voltages will vary from the initial to the updated DAC command.

4.10 Power supply sequencing

No specific power supply sequencing is required on the STHVDAC-253MTG.

The STHVDAC-253MTG is fully functional only once both VIO and AVDD are supplied.

4.11 Trigger mode

To meet precise timing requirements and avoid RFFE interface traffic congestion at critical timing, trigger mode has been implemented in the RFFE interface.

Three triggers (TRIG0, TRIG1 and TRIG2) are available and can be controlled through the RFFE interface.

By default, registers 2 to 4 (DAC A, DAC B and DAC C) are associated to TRIG0. Each DAC can be independently mapped to TRIG0, TRIG1 or TRIG2 by controlling trigger configuration bits in registers 9 and 10.

Trigger mode enabled (default mode):

By default, the different triggers are enabled and the device is running in triggered mode.

In this case, once in ACTIVE mode, the following sequence must be followed to control the HVDAC outputs:

- Send any valid write command sequence to Register#0 - Register#10. The new DAC register values will be temporarily stored in shadow registers.
- Send a register#28 write command sequence, setting trigger bits (D2 to D0) and keeping trigger mask bits (D5 to D3) low. The shadow registers will be loaded to destination registers and this will trigger the corresponding DAC outputs to their new values.

Trigger mode disabled:

The different triggers are disabled setting corresponding trigger mask bits in register#28 (D5 to D3).

In this case, any valid DAC register write command sequence is directly loaded to the destination register, directly triggering the corresponding DAC output to its new value.

The following logic diagram illustrates the trigger mode function. By default the trigger mode is enabled and the DATA are first sent to SHADOW registers, then transferred into DAC register once valid trigger is sent to register#28.

Figure 7. Logic diagram trigger mode / default trigger mapping

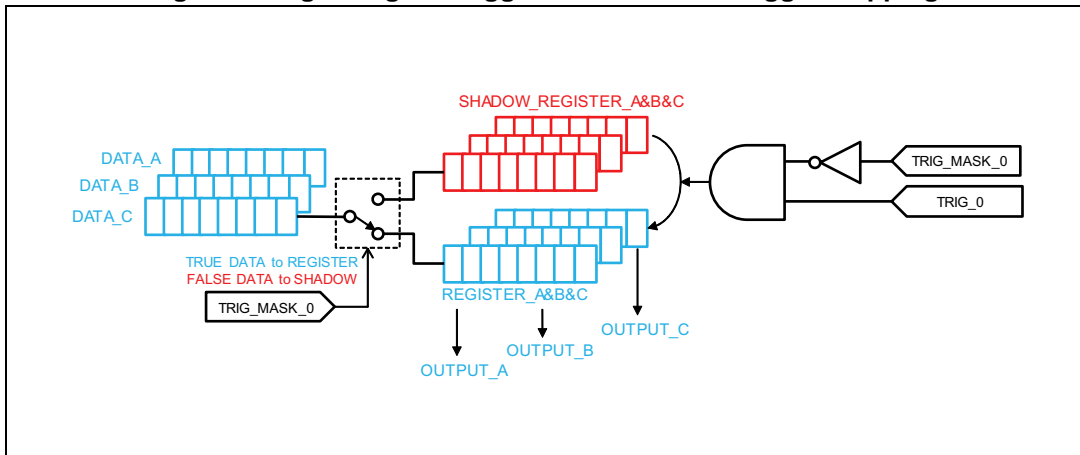

4.12 Settling time

The STHVDAC will set the bias voltage of the tunable capacitors within 10 μ s typical after

- Bus Park (BP) of register #28 write sequence data frame if trigger mode is enabled.
- Parity Bit (P) of each data frame of register #1 to 8 extended write sequence if trigger mode is disabled.

Table 7. Timing

| Conditions: AV _{DD} from 2.5 to 5 V, V _{I/O} from 1.65 to 1.95 V, T _{amb} from -30 °C to +85 °C, OUTA-OUTC unless otherwise specified | | | | | | |
|--|---|--|------|------|------|---------|
| Symbol | Parameter | Conditions | Min. | Typ. | Max. | Unit |
| T _{active} | Activation time | Internal voltages activation time from Low Power (or shutdown) to Active mode Chv=33 nF | - | 100 | 250 | μ s |
| T _{set+} | Output positive setting time @ 95% of delta V | V _{out} 2 V to 20 V, equivalent load of 12 k Ω and 2.7 nF / Normal mode | - | 10 | 25 | μ s |
| T _{set-} | Output negative setting time @ 95% of delta V | V _{out} 20 V to 2 V, equivalent load of 12 k Ω and 2.7 nF / Normal mode | - | 10 | 25 | μ s |

4.13 Recommended operation with trigger and extended commands

It is recommended to use trigger so that outputs will be activated by write to REG_28. By default the device is set in triggered mode.

PWR_MODE bits from REG_28 have been duplicated in REG_0 to ensure the device can be setup from low power to active using one single extended mode RFFE command, as illustrated on *Figure 8*.

By default, DAC_A, B and C are mapped to TRIG0 and DAC_D, E and F to TRIG1. In this configuration, DAC values can be updated through RFFE extended commands, and DAC outputs for a given antenna synchronized through trigger control.

Each DAC output can be mapped to TRIG0, 1 or 2 through registers 9 to 11.

The timing diagram below represents recommended operation when default trigger mapping and extended write are in use.

Figure 8. Operation with trigger and extended commands

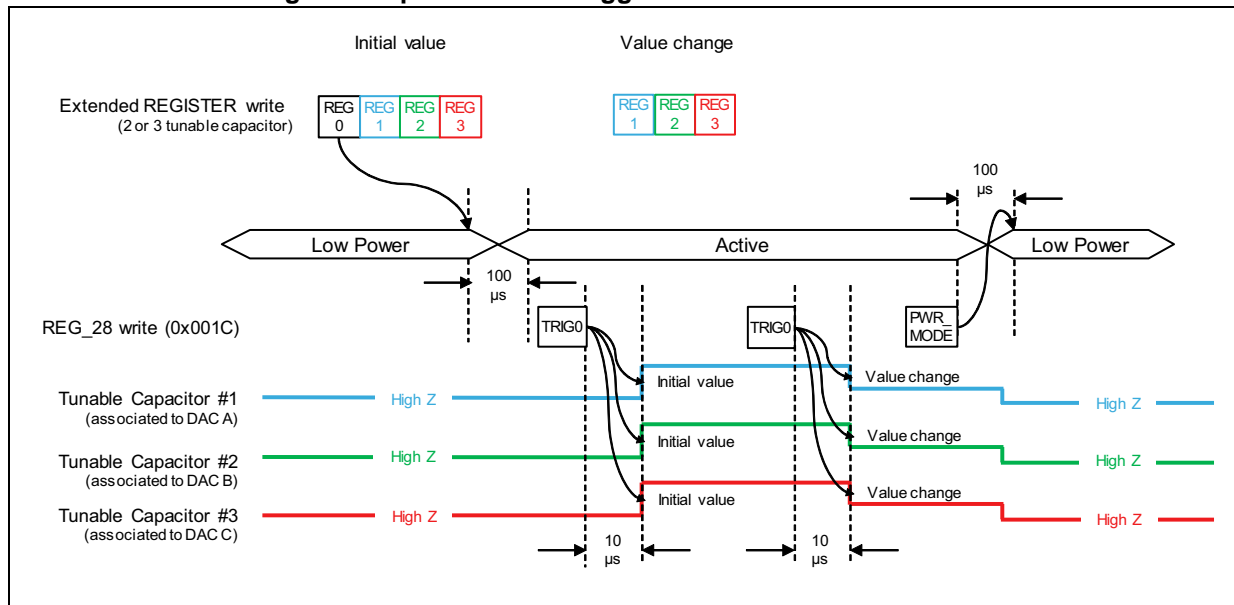

4.14 Registers table

The STHVDAC is embedding 12 x 8 bits registers. Registers content is described in [Figure 9](#), and registers default values are provided in [Figure 10](#).

Figure 9. Registers table

| Reg # | Reg address hex | Reg address bin | D7 MSB | D6 | D5 | D4 | D3 | D2 | D1 | D0 LSB | Access type | Default Triggers | |
|-------|-----------------|-----------------|-----------------------------------|---------|------------------------|--------------|---------------|------------|---------------|------------|-------------|------------------|----|
| 0 | 00h | [00000] | x | x | Active | 0 | 1 | 0 | PWR_MODE | | RW | no | |
| 1 | 01h | [00001] | glide_step_delay | | | | | Glide A EN | Glide B EN | Glide C EN | | RW | no |
| 2 | 02h | [00010] | TM_A | DAC A | | | | | | RW | TRIG0 | | |
| 3 | 03h | [00011] | TM_B | DAC B | | | | | | RW | TRIG0 | | |
| 4 | 04h | [00100] | TM_C | DAC C | | | | | | RW | TRIG0 | | |
| 9 | 09h | [01001] | TRIG_CONFIG_A | | PTIC_Select_A | | TRIG_CONFIG_B | | PTIC_Select_B | | RW | no | |
| 10 | 0Ah | [01010] | TRIG_CONFIG_C | | PTIC_Select_C | | | | | | RW | no | |
| 26 | 1Ah | [11010] | SW reset | | | RFFE status | | | | | RW | no | |
| 28 | 1Ch | [11100] | PWR_MODE | | Trig mask 2 | Trig mask 1 | Trig mask 0 | TRIG2 | TRIG1 | TRIG0 | RW | no | |
| 29 | 1Dh | [11101] | SELSID1 | SELSID0 | PRODUCT ID [xx000100b] | | | | | | R | no | |
| 30 | 1Eh | [11110] | MANUFACTURER ID [7,0] [00000100b] | | | | | | | | R | no | |
| 31 | 1Fh | [11111] | 0 | 0 | MANUF_ID[9,8] [01b] | USID [0111b] | | | | RW | no | | |

Figure 10. Registers default values

| Reg # | Reg address hex | Reg address bin | D7 | D6 | D5 | D4 | D3 | D2 | D1 | D0 |
|-------|-----------------|-----------------|------------|------------|----|----|----|----|----|----|
| 0 | 00h | [00000] | 0 | 0 | 0 | 0 | 1 | 0 | 0 | 0 |
| 1 | 01h | [00001] | 0 | 0 | 0 | 0 | 0 | 0 | 0 | 0 |
| 2 | 02h | [00010] | 0 | 0 | 0 | 0 | 0 | 0 | 0 | 0 |
| 3 | 03h | [00011] | 0 | 0 | 0 | 0 | 0 | 0 | 0 | 0 |
| 4 | 04h | [00100] | 0 | 0 | 0 | 0 | 0 | 0 | 0 | 0 |
| 9 | 09h | [01001] | 0 | 0 | 0 | 0 | 0 | 0 | 0 | 0 |
| 10 | 0Ah | [01010] | 0 | 0 | 0 | 0 | 0 | 1 | 0 | 0 |
| 26 | 1Ah | [11010] | 0 | 0 | 0 | 0 | 0 | 0 | 0 | 0 |
| 28 | 1Ch | [11100] | 0 | 0 | 0 | 0 | 0 | 0 | 0 | 0 |
| 29 | 1Dh | [11101] | SELSID1(*) | SELSID0(*) | 0 | 0 | 0 | 1 | 0 | 0 |
| 30 | 1Eh | [11110] | 0 | 0 | 0 | 0 | 0 | 1 | 0 | 0 |
| 31 | 1Fh | [11111] | 0 | 0 | 0 | 1 | 0 | 1 | 1 | 1 |

Note: (*)Reg#29 - D7 and D6 (MSBs DEVICE ID) default values are directly tied to SELID1 and SELID0 pins, respectively. These bits are set to 1 if the corresponding pin is tied to V_{IO}, and set to 0 if tied to GND. This will allow to have up to four HVDAC with different product ID connected to the same RFFE master.

4.15 RFFE interface - registers content description

Registers content and control are further described in tables#8 to 14 and *Figure 11*.

Table 8. STHVDAC mode selection

| D7 | D6 | Reg #0 D5 | Comments |
|----------|----|-----------|---------------------------------------|
| PWR_MODE | | Active | |
| 0 | 0 | 0 | Active mode - idle |
| 0 | 0 | 1 | Active mode - operating |
| 0 | 1 | x | Start up / registers reset to default |
| 1 | 0 | x | Low power |
| 1 | 1 | x | N/A |

PWR_MODE bits located in D7-D6 of reg#28, and duplicated in D1-D0 of reg#0.

Table 9. STHVDAC trigger control register - reg#28

| D5 | D4 | D3 | D2 | D1 | D0 | Comments |
|-------------|-------------|-------------|--------|--------|--------|---|
| Trig mask 2 | Trig mask 1 | Trig mask 0 | Trig 2 | Trig 1 | Trig 0 | |
| 0 | 0 | 0 | 0 | 0 | 0 | Triggers 2, 1, 0 are unmasked / triggers 2, 1, 0 are disabled (default) |
| 0 | 0 | 0 | 1 | 1 | 1 | Triggers 2, 1, 0 are unmasked / triggers 2, 1, 0 are enabled |
| 1 | 1 | 1 | 0 | 0 | 0 | Triggers 2, 1, 0 are masked |

Table 10. HVDAC unique slave identifier control - reg#31

| D7 | D6 | D5 | D4 | D3 | D2 | D1 | D0 | Comments |
|-------|----|-----------------------|----|------|----|----|----|--|
| spare | | MANUFACTURER_ID [9,8] | | USID | | | | |
| 0 | 0 | 0 | 1 | 0 | 1 | 1 | 1 | Default value |
| 0 | 0 | 0 | 1 | x | x | x | x | USID can be modified by RFFE master, see detailed programming procedure in MIPI RFFE specification |

Table 11. Glide step delay control - reg#1

| Address | D7 | D6 | D5 | D4 | D3 | Comments |
|---------|------------------------------|----|----|----|----|----------|
| | Glide step delay DAC A, B, C | | | | | |
| [00001] | 0 | 0 | 0 | 0 | 0 | 2 μs |
| | 0 | 0 | 0 | 0 | 1 | 4 μs |
| | 0 | 0 | 0 | 1 | 0 | 6 μs |
| | | | | | | |
| | 1 | 1 | 1 | 1 | 0 | 62 μs |
| | 1 | 1 | 1 | 1 | 1 | 64 μs |

Table 12. Glide enable bits - reg#1

| Address | D2 | D1 | D0 | Comments |
|---------|------------|------------|------------|--|
| | Glide A EN | Glide B EN | Glide C EN | |
| [00001] | 0 | 0 | 0 | Glide enable = 0: DAC mode set by DAC register MSB |
| | 1 | 1 | 1 | Glide enable = 1: DAC in glide mode |

Table 13. DAC control registers - reg#2, 3, 4

| Address | D7 MSB | D6 | D5 | D4 | D3 | D2 | D1 | D0 LSB | Comments |
|---------|--------|-------|----|----|----|----|----|--------|---|
| [00010] | TM_A | DAC A | | | | | | | D7: Turbo mode control: 0: Turbo OFF 1: Turbo ON D7 is disregarded if glide mode is enabled D6-D0: DAC output |
| [00011] | TM_B | DAC B | | | | | | | |
| [00100] | TM_C | DAC C | | | | | | | |

Table 14. RFFE status register - reg#26

| Reg# | Address | D7 MSB | D6 | D5 | D4 | D3 | D2 | D1 | D0 LSB | Access type | Triggered |
|------|---------|----------|-------------|----|----|----|----|----|--------|-------------|-----------|
| 26 | [11010] | SW reset | RFFE status | | | | | | | RW | no |

D7: Software reset:

- 0: Normal operation
- 1: Software reset - all configurable registers are reset to their default values (except USID and reg#28)

D6-D0: RFFE status and error reporting

Figure 11. Trigger configuration and PTIC selection registers - reg#9, 10 and 11

| Reg # | Reg address hex | Reg address bin | D7 MSB | D6 | D5 | D4 | D3 | D2 | D1 | D0 LSB | Access type | Default Triggers |
|-------|-----------------|-----------------|---------------|----|---------------|----|---------------|----|---------------|--------|-------------|------------------|
| 9 | 09h | [01001] | TRIG_CONFIG_A | | PTIC_Select_A | | TRIG_CONFIG_B | | PTIC_Select_B | | RW | no |
| 10 | 0Ah | [01010] | TRIG_CONFIG_C | | PTIC_Select_C | | | | | | RW | no |
| 11 | 0Bh | [01011] | | | | | | | | | RW | no |

Each DAC output can be connected to RFFE TRIG#0, TRIG#1 or TRIG2
 TRIG CONFIG x : 00b DAC x triggered through TRIG#0 default for DAC A, B & C
 TRIG CONFIG x : 01b DAC x triggered through TRIG#1
 TRIG CONFIG x : 10b DAC x triggered through TRIG#2

In TURBO mode, Each DAC output is optimized to supply 4 different RC loads (corresponding to 4 different PTIC designs)

| | | | |
|---------------------------|----------------------|---------------|---|
| PTIC_Selection_bits = 00b | Rload = 12k Ω | Cload = 2.7nF | (24 capacitor stack STPTIC F1, G1, G2 series) |
| PTIC_Selection_bits = 01b | Rload = 17k Ω | Cload = 2.7nF | (36 capacitor stack STPTIC H1, L2 series) |
| PTIC_Selection_bits = 10b | Rload = 22k Ω | Cload = 2.7nF | (48 capacitor stack STPTIC L1, L2 series) |
| PTIC_Selection_bits = 11b | Rload = 27k Ω | Cload = 2.7nF | (Spare) |

5 Serial interface specification

Table 15. Interface specifications

| Conditions: AV _{DD} from 2.3 to 5 V, VIO from 1.65 to 1.95 V, T _{amb} from -30 °C to +85 °C, unless otherwise specified | | | | | | |
|---|-------------------------|-------------------------------------|-------|------|------|------|
| Symbol | Parameter | Conditions | Min. | Typ. | Max. | Unit |
| F _{CLK} | Clock Frequency | | | - | 26 | MHz |
| T _{CLK} | Clock Period | | 38.4 | - | | ns |
| T _{HIGH} | Clock High Time | | 11.25 | - | | ns |
| T _{LOW} | Clock Low Time | | 11.25 | - | | ns |
| TD _{setup} | DATA setup time | Relative to 30% of CLK falling edge | 1 | - | | ns |
| TD _{hold} | DATA hold time | Relative to 70% of CLK falling edge | 5 | - | | ns |
| C _{CLK} | CLK pin input capacitor | | | - | 5 | pF |
| C _{DATA} | DATA pin input | | | - | 5 | pF |

Figure 12. Operation register WRITE command sequence

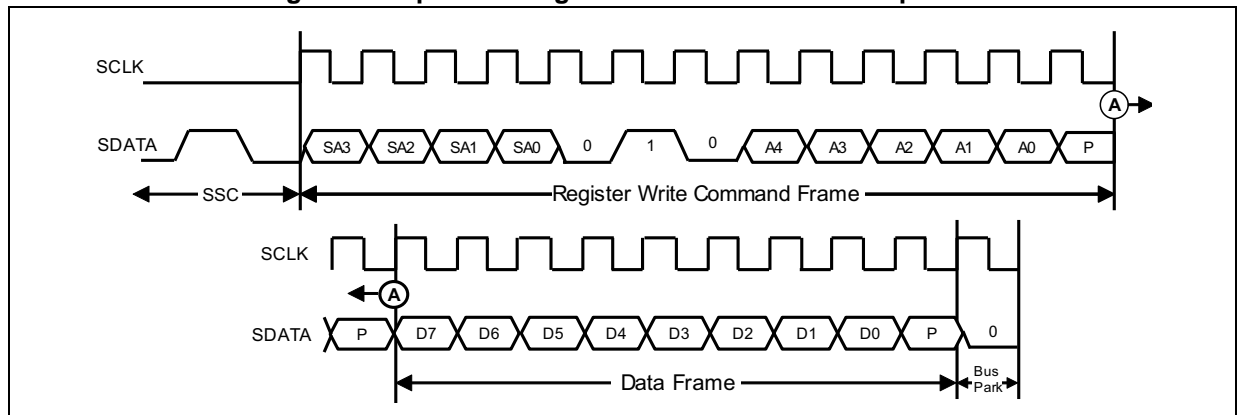

Figure 13. Operation register READ command sequence

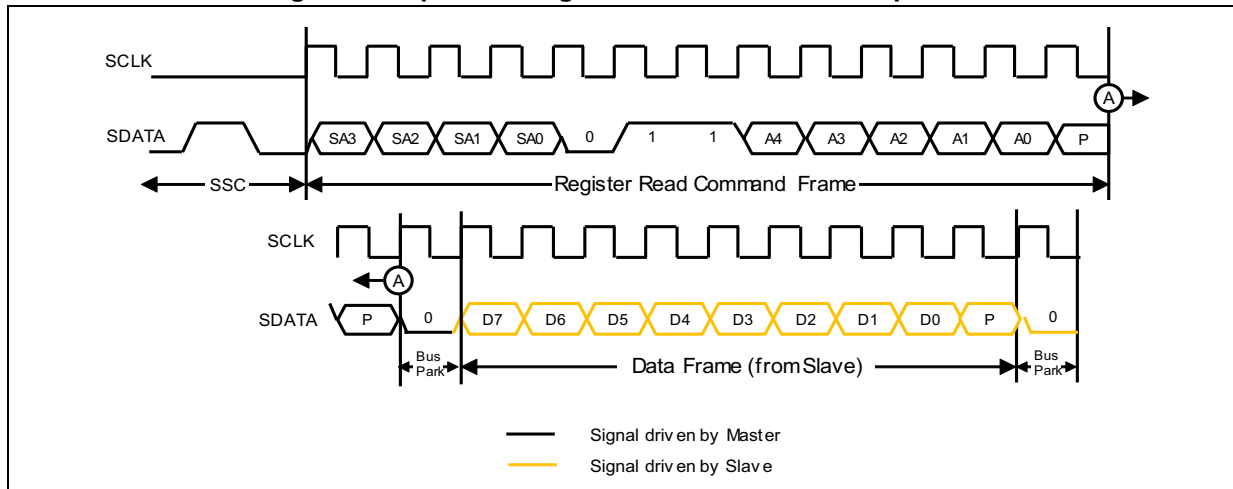
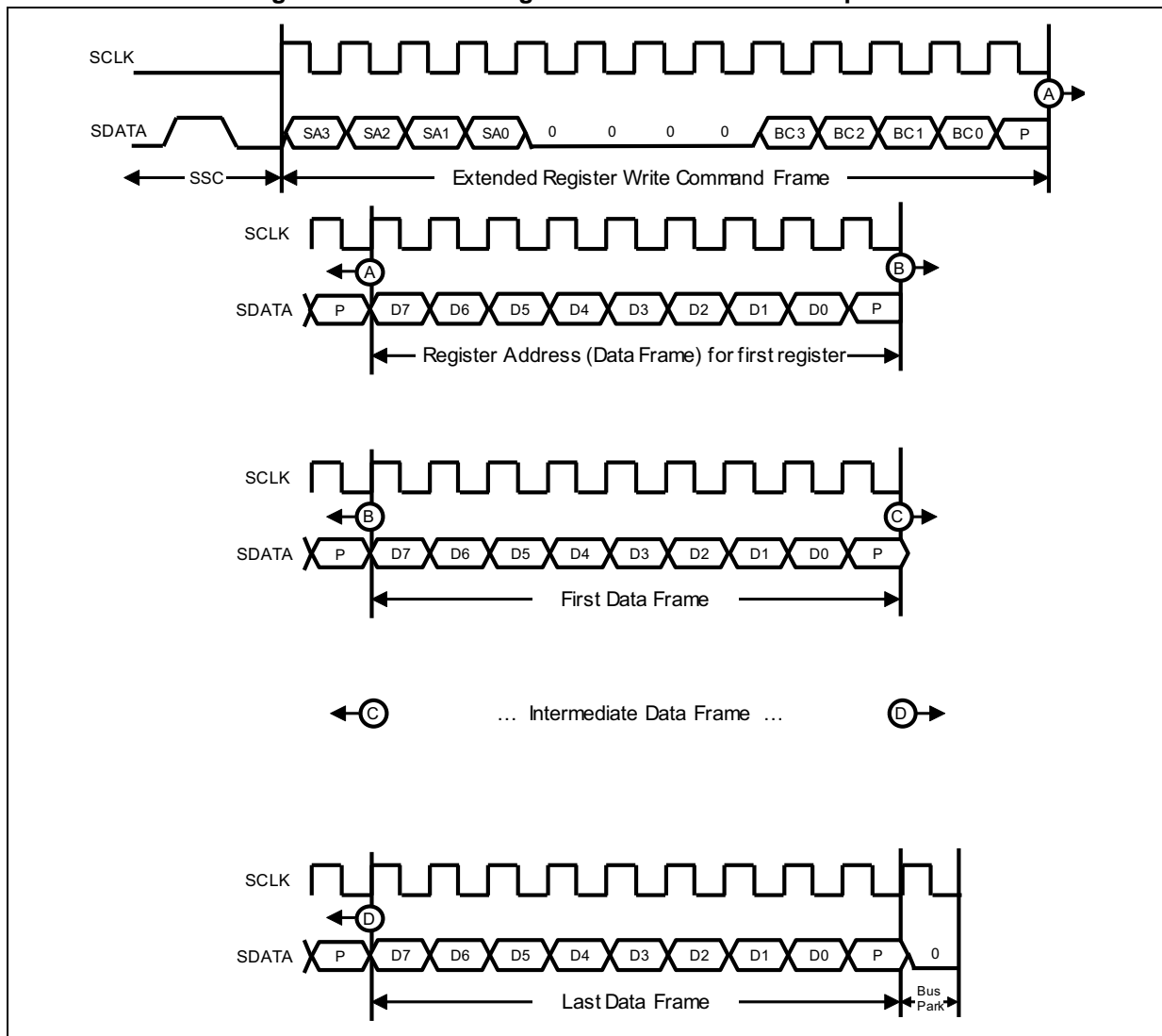

Figure 14. Extended register WRITE command sequence



6 Application schematic

Figure 15. Recommended application schematic

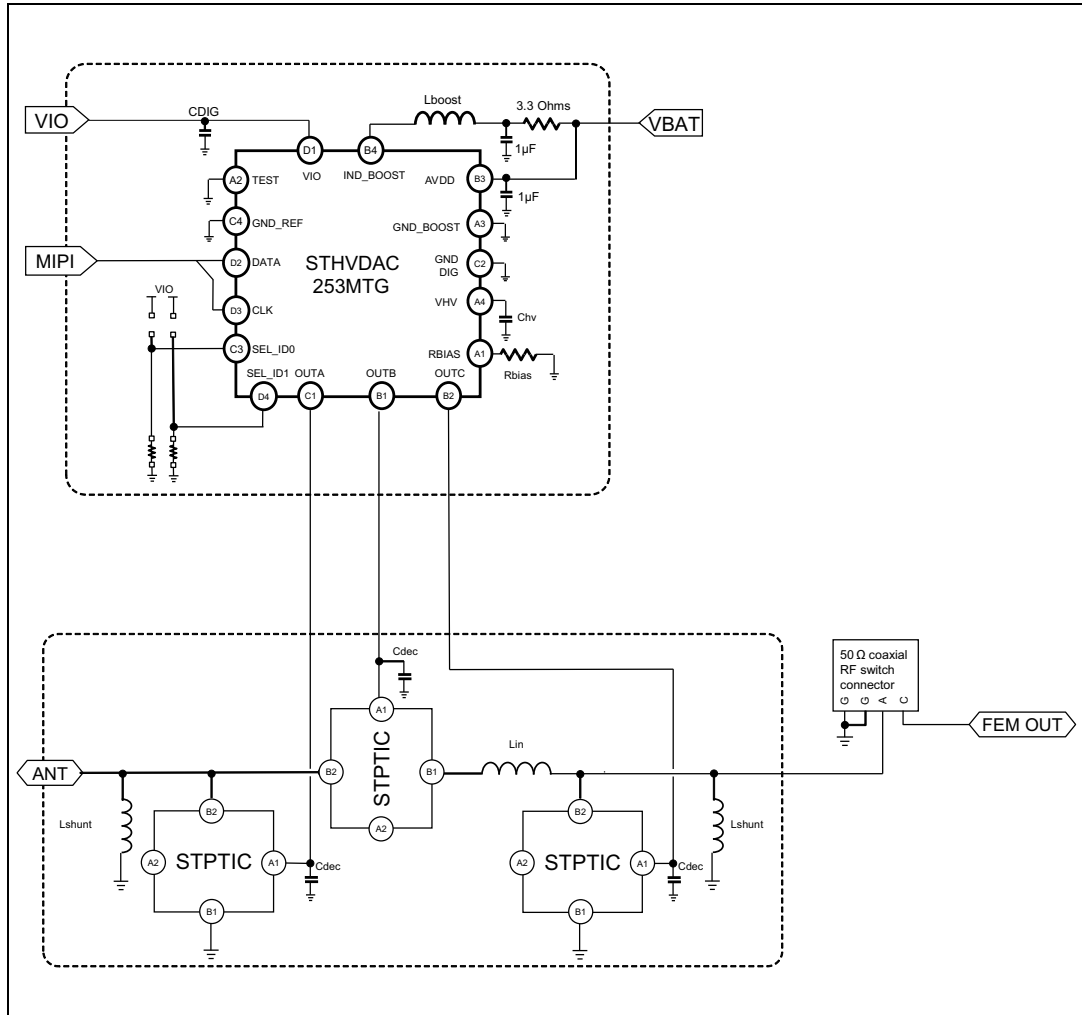

Figure 16. Evaluation board

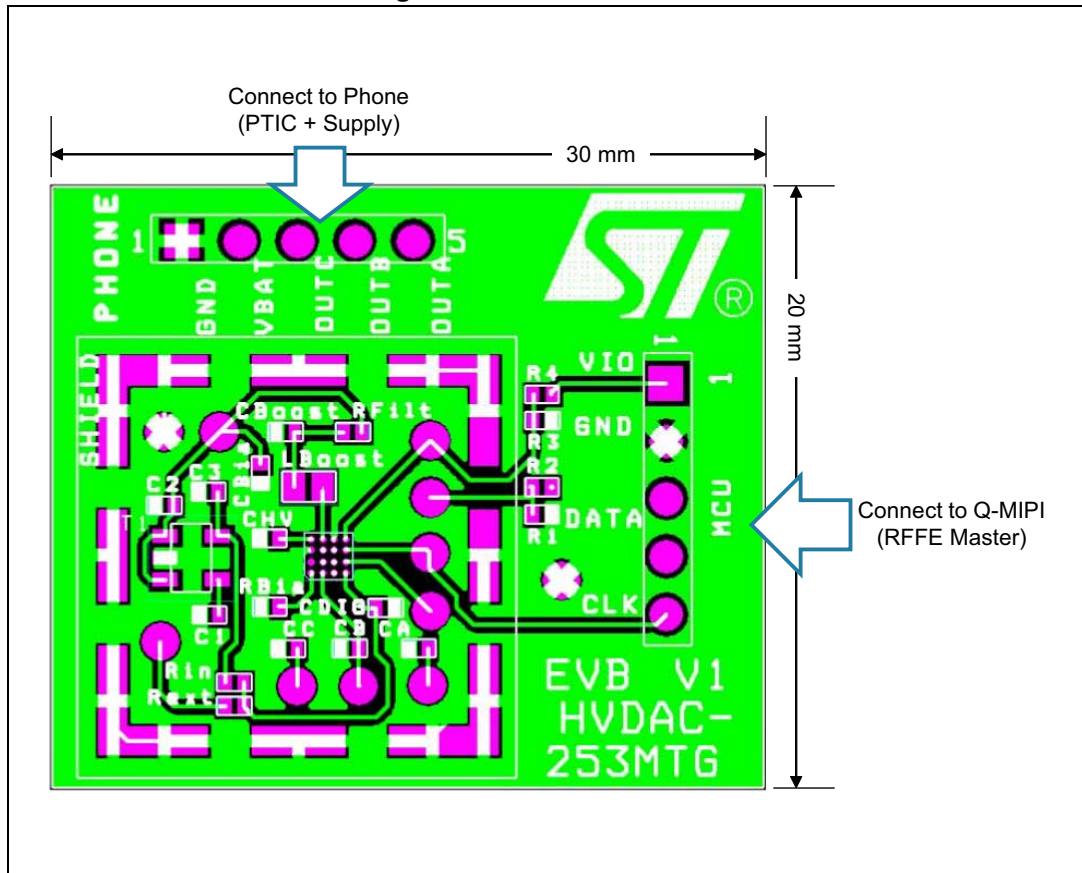

Table 16. Recommended external BOM

| Components | Description | Nominal value | Package (inch) | Package (mm) | Recommended P/N |
|------------|-----------------------------|----------------|----------------|--------------|-------------------------------|
| Cboost | Boost supply capacitor | 1 μ F | 0201 | 0603 | AVX: 02016D105MAT2A |
| Lboost | Boost inductance | 15 μ H | 0603 | 1608 | COILCRAFT: 0603LS-153XGL |
| Rbias | Reference bias resistor, 1% | 110 k Ω | 0201 | 0603 | Multicomp: MC 0.0625W 0402 1% |
| Chv | Boost output capacitor, 50V | 33 nF | 0402 | 1005 | Murata: GRM155R61H333KE19 |
| Cdec | Decoupling capacitor, 50V | 100 pF | 0201 | 0603 | TDK: C0603COG1H101J |

7 Package information

In order to meet environmental requirements, ST offers these devices in different grades of ECOPACK® packages, depending on their level of environmental compliance. ECOPACK® specifications, grade definitions and product status are available at: www.st.com. ECOPACK® is an ST trademark.

7.1 Flip-chip package information

Figure 17. Flip-chip package outline

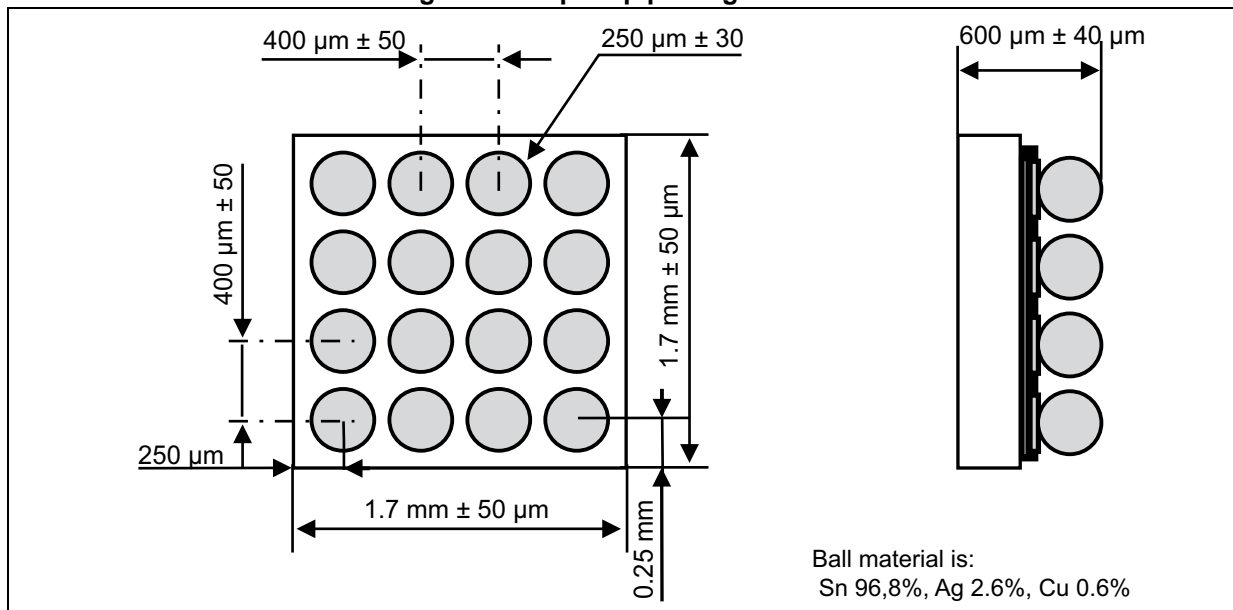

Figure 18. Footprint

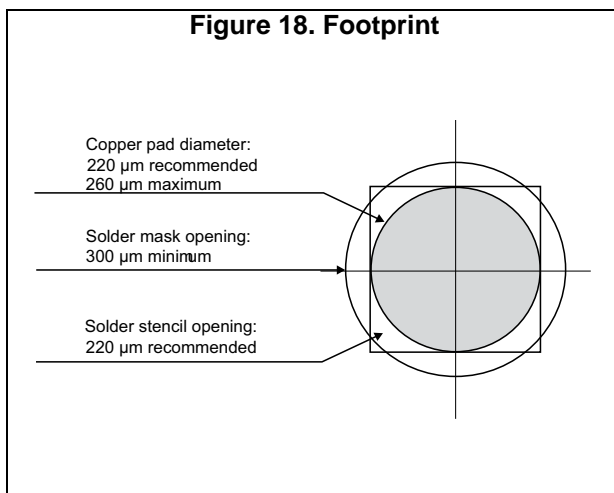

Figure 19. Marking

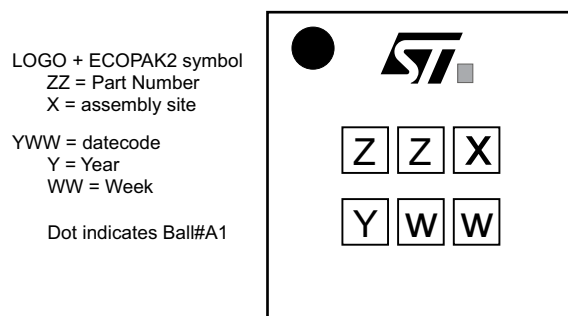
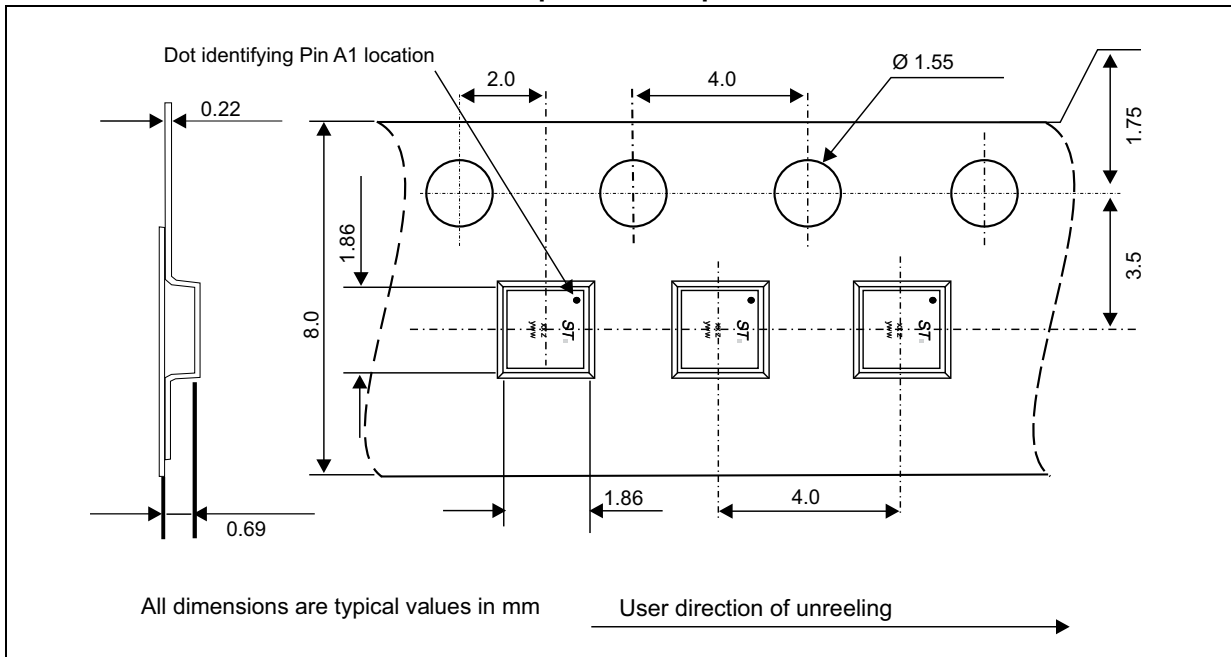

Table 17. Tape and reel specification



8 Ordering information

Table 18. Ordering information

| Part Number | Marking | Base Qty. | Delivery mode |
|------------------|---------|-----------|---------------|
| STHVDAC-253MTGF3 | PU | 5000 | Tape & reel |

Note: More information is available in the STMicroelectronics Application note:
AN1235: "Flip Chip: Package description and recommendations for use"

9 Revision history

Table 19. Document revision history

| Date | Revision | Changes |
|-------------|----------|-------------------------------------|
| 10-Jun-2015 | 1 | Initial release. |
| 24-Jun-2015 | 2 | Updated description. |
| 9-Jul-2015 | 3 | Updated figure16. |
| 17-Nov-2015 | 4 | Updated Figure 15 . |

IMPORTANT NOTICE – PLEASE READ CAREFULLY

STMicroelectronics NV and its subsidiaries ("ST") reserve the right to make changes, corrections, enhancements, modifications, and improvements to ST products and/or to this document at any time without notice. Purchasers should obtain the latest relevant information on ST products before placing orders. ST products are sold pursuant to ST's terms and conditions of sale in place at the time of order acknowledgement.

Purchasers are solely responsible for the choice, selection, and use of ST products and ST assumes no liability for application assistance or the design of Purchasers' products.

No license, express or implied, to any intellectual property right is granted by ST herein.

Resale of ST products with provisions different from the information set forth herein shall void any warranty granted by ST for such product.

ST and the ST logo are trademarks of ST. All other product or service names are the property of their respective owners.

Information in this document supersedes and replaces information previously supplied in any prior versions of this document.

© 2015 STMicroelectronics – All rights reserved