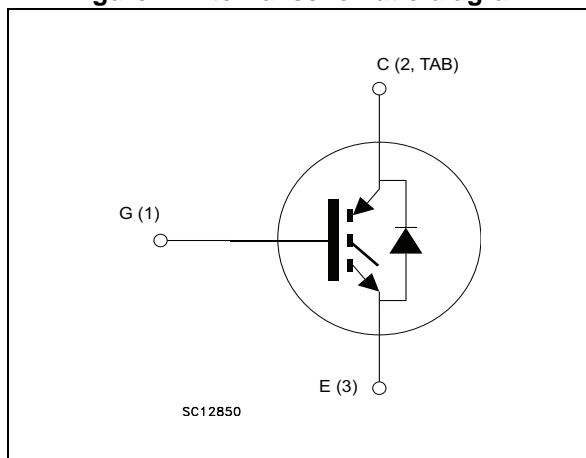

Figure 1. Internal schematic diagram



Features

- High speed switching
- Tight parameters distribution
- Safe paralleling
- Low thermal resistance
- Short circuit rated
- Ultrafast soft recovery antiparallel diode

Applications

- Inverter
- UPS
- PFC

Description

This device is an IGBT developed using an advanced proprietary trench gate and field stop structure. This IGBT series offers the optimum compromise between conduction and switching losses, maximizing the efficiency of very high frequency converters. Furthermore, a positive $V_{CE(sat)}$ temperature coefficient and very tight parameter distribution result in easier paralleling operation.

Table 1. Device summary

Order codes	Marking	Package	Packaging
STGB30H60DF	GB30H60DF	D ² PAK	Tape and reel
STGF30H60DF	GF30H60DF	TO-220FP	Tube
STGP30H60DF	GP30H60DF	TO-220	
STGW30H60DF	GW30H60DF	TO-247	

Contents

1	Electrical ratings	3
2	Electrical characteristics	4
2.1	Electrical characteristics (curves)	7
3	Test circuits	11
4	Package mechanical data	12
5	Packaging mechanical data	20
6	Revision history	23



1 Electrical ratings

Table 2. Absolute maximum ratings

Symbol	Parameter	Value		Unit
		TO-220 D ² PAK TO-247	TO-220FP	
V _{CES}	Collector-emitter voltage (V _{GE} = 0)	600		V
I _C	Continuous collector current at T _C = 25 °C	60	60 ⁽¹⁾	A
I _C	Continuous collector current at T _C = 100 °C	30	30 ⁽¹⁾	A
I _{CP} ⁽²⁾	Pulsed collector current	120	120 ⁽¹⁾	A
V _{GE}	Gate-emitter voltage	±20		V
I _F	Continuous forward current T _C = 25 °C	60	60 ⁽¹⁾	A
I _F	Continuous forward current at T _C = 100 °C	30	30 ⁽¹⁾	A
I _{FP} ⁽²⁾	Pulsed forward current	120	120 ⁽¹⁾	A
P _{TOT}	Total dissipation at T _C = 25 °C	260	37 ⁽¹⁾	W
T _{STG}	Storage temperature range	- 55 to 150		°C
T _J	Operating junction temperature	- 40 to 175		

1. Limited by maximum junction temperature

2. Pulse width limited by maximum junction temperature and turn-off within RBSOA.

Table 3. Thermal data

Symbol	Parameter	Value				Unit
		D ² PAK	TO-220FP	TO-220	TO-247	
R _{thJC}	Thermal resistance junction-case IGBT	0.58	4	0.58		°C/W
R _{thJC}	Thermal resistance junction-case diode	2.5	5.6	2.5		°C/W
R _{thJA}	Thermal resistance junction-ambient	62.5			50	°C/W

2 Electrical characteristics

$T_J = 25\text{ °C}$ unless otherwise specified.

Table 4. Static

Symbol	Parameter	Test condition	Min.	Typ.	Max.	Unit
$V_{(BR)CES}$	Collector-emitter breakdown voltage ($V_{GE} = 0$)	$I_C = 2\text{ mA}$	600			V
$V_{CE(sat)}$	Collector-emitter saturation voltage	$V_{GE} = 15\text{ V}, I_C = 30\text{ A}$		2.0	2.4	V
		$V_{GE} = 15\text{ V}, I_C = 30\text{ A}$ $T_J = 175\text{ °C}$		2.4		V
$V_{GE(th)}$	Gate threshold voltage	$V_{CE} = V_{GE}, I_C = 1\text{ mA}$	5.0	6.0	7.0	V
I_{CES}	Collector cut-off current ($V_{GE} = 0$)	$V_{CE} = 600\text{ V}$			25	μA
I_{GES}	Gate-emitter leakage current ($V_{CE} = 0$)	$V_{GE} = \pm 20\text{ V}$			250	nA

Table 5. Dynamic

Symbol	Parameter	Test condition	Min.	Typ.	Max.	Unit
C_{ies}	Input capacitance	$V_{CE} = 25\text{ V}, f = 1\text{ MHz},$ $V_{GE} = 0$	-	3600	-	pF
C_{oes}	Output capacitance			130		pF
C_{res}	Reverse transfer capacitance			65		pF
Q_g	Total gate charge	$V_{CC} = 400\text{ V}, I_C = 30\text{ A},$ $V_{GE} = 15\text{ V}$	-	105	-	nC
Q_{ge}	Gate-emitter charge			30		nC
Q_{gc}	Gate-collector charge			35		nC

Table 6. Switching on/off (inductive load)

Symbol	Parameter	Test condition	Min.	Typ.	Max.	Unit
$t_{d(on)}$	Turn-on delay time	$V_{CE} = 400\text{ V}$, $I_C = 30\text{ A}$, $R_G = 10\ \Omega$, $V_{GE} = 15\text{ V}$	-	50	-	ns
t_r	Current rise time			15		ns
$(di/dt)_{on}$	Turn-on current slope			1600		A/ μ s
$t_{d(on)}$	Turn-on delay time	$V_{CE} = 400\text{ V}$, $I_C = 30\text{ A}$, $R_G = 10\ \Omega$, $V_{GE} = 15\text{ V}$ $T_J = 175\text{ }^\circ\text{C}$	-	47	-	ns
t_r	Current rise time			17		ns
$(di/dt)_{on}$	Turn-on current slope			1400		A/ μ s
$t_r(V_{off})$	Off voltage rise time	$V_{CE} = 400\text{ V}$, $I_C = 30\text{ A}$, $R_G = 10\ \Omega$, $V_{GE} = 15\text{ V}$	-	20	-	ns
$t_{d(off)}$	Turn-off delay time			160		ns
t_f	Current fall time			60		ns
$t_r(V_{off})$	Off voltage rise time	$V_{CE} = 400\text{ V}$, $I_C = 30\text{ A}$, $R_G = 10\ \Omega$, $V_{GE} = 15\text{ V}$ $T_J = 175\text{ }^\circ\text{C}$	-	22	-	ns
$t_{d(off)}$	Turn-off delay time			146		ns
t_f	Current fall time			88		ns
t_{sc}	Short circuit withstand time	$V_{CC} \leq 360\text{ V}$, $V_{GE} = 15\text{ V}$	3	6	-	μ s

Table 7. Switching energy (inductive load)

Symbol	Parameter	Test condition	Min.	Typ.	Max.	Unit
$E_{on}^{(1)}$	Turn-on switching losses	$V_{CE} = 400\text{ V}$, $I_C = 30\text{ A}$, $R_G = 10\ \Omega$, $V_{GE} = 15\text{ V}$	-	0.35	-	mJ
$E_{off}^{(2)}$	Turn-off switching losses			0.40		mJ
E_{ts}	Total switching losses			0.75		mJ
$E_{on}^{(1)}$	Turn-on switching losses	$V_{CE} = 400\text{ V}$, $I_C = 230\text{ A}$, $R_G = 10\ \Omega$, $V_{GE} = 15\text{ V}$ $T_J = 175\text{ }^\circ\text{C}$	-	0.61	-	mJ
$E_{off}^{(2)}$	Turn-off switching losses			0.84		mJ
E_{ts}	Total switching losses			1.45		mJ

1. Energy losses include reverse recovery of the diode.
2. Turn-off losses include also the tail of the collector current.

Table 8. Collector-emitter diode

Symbol	Parameter	Test condition	Min.	Typ.	Max.	Unit
V_F	Forward on-voltage	$I_F = 30\text{ A}$	-	2.0	2.3	V
		$I_F = 30\text{ A}, T_J = 175\text{ °C}$		1.5		V
t_{rr}	Reverse recovery time	$V_r = 400\text{ V}, I_F = 30\text{ A};$ $di_F/dt = 400\text{ A} / \mu\text{s}$	-	110	-	ns
Q_{rr}	Reverse recovery charge			136		nC
I_{rrm}	Reverse recovery current			2.5		A
t_{rr}	Reverse recovery time	$V_r = 400\text{ V}, I_F = 30\text{ A};$ $di_F/dt = 400\text{ A} / \mu\text{s}$ $T_J = 175\text{ °C}$	-	190	-	ns
Q_{rr}	Reverse recovery charge			506		nC
I_{rrm}	Reverse recovery current			5.3		A

2.1 Electrical characteristics (curves)

Figure 2. Output characteristics ($T_J = 25^\circ\text{C}$)

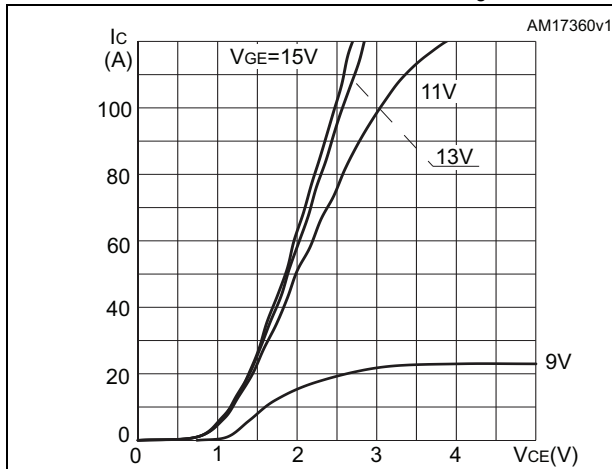

Figure 3. Output characteristics ($T_J = 175^\circ\text{C}$)

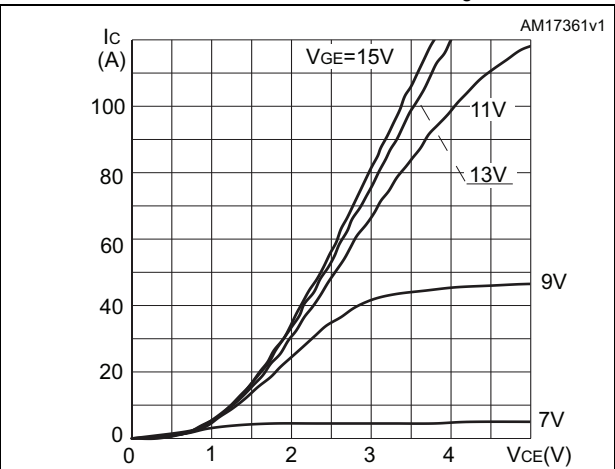

Figure 4. Transfer characteristics

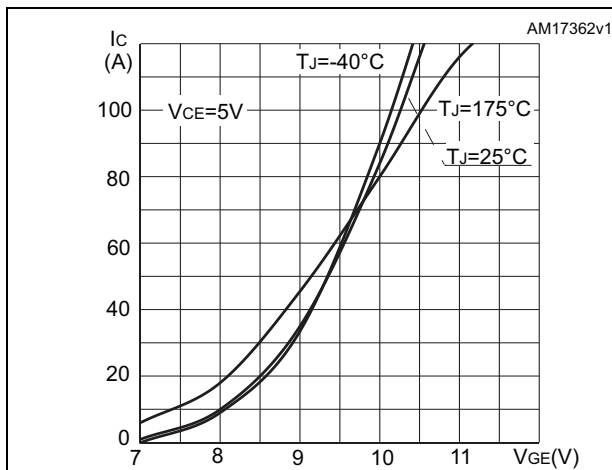

Figure 5. Normalized $V_{GE(th)}$ vs. junction temperature

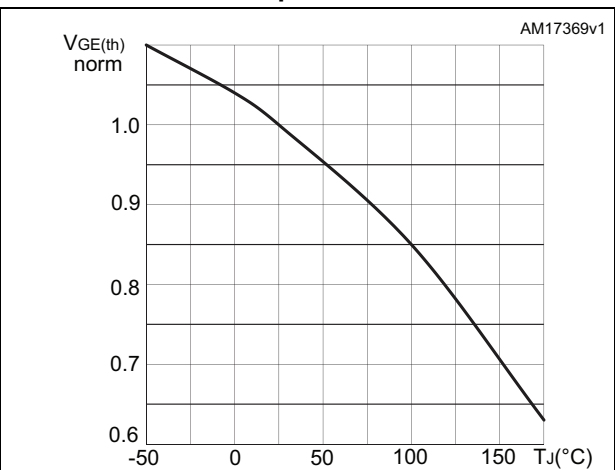

Figure 6. Power dissipation vs. case temperature for D²PAK, TO-220 and TO-247

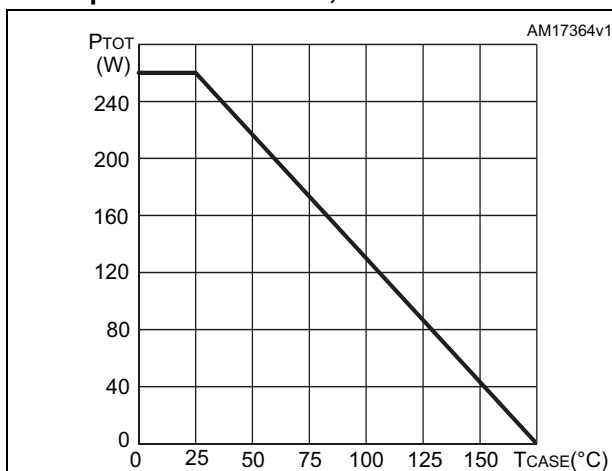

Figure 7. Power dissipation vs. case temperature for TO-220FP

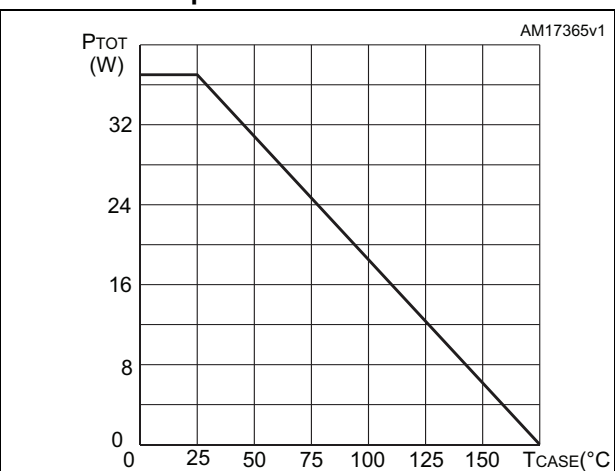

Figure 8. Collector current vs. frequency for D²PAK, TO-220 and TO-247

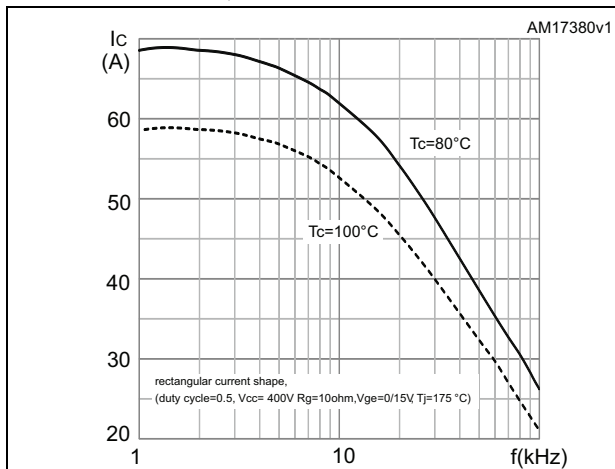

Figure 9. Collector current vs. frequency for TO-220FP

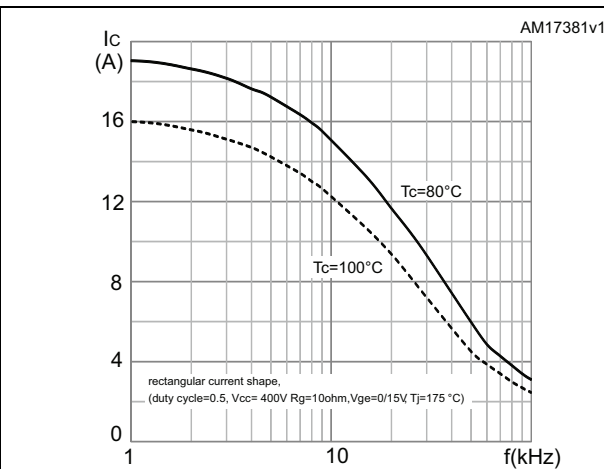

Figure 10. V_{CE(sat)} vs. junction temperature

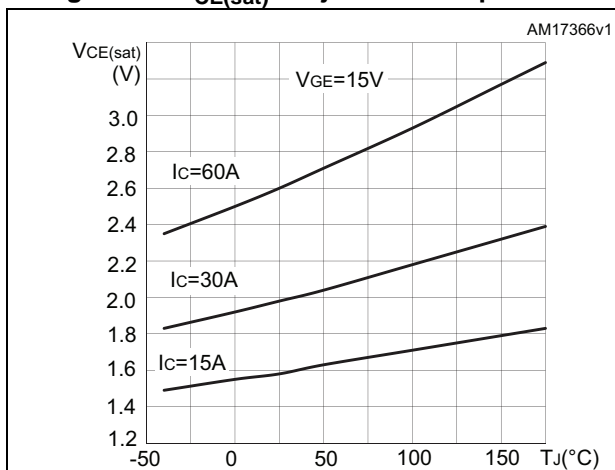

Figure 11. V_{CE(sat)} vs. collector current

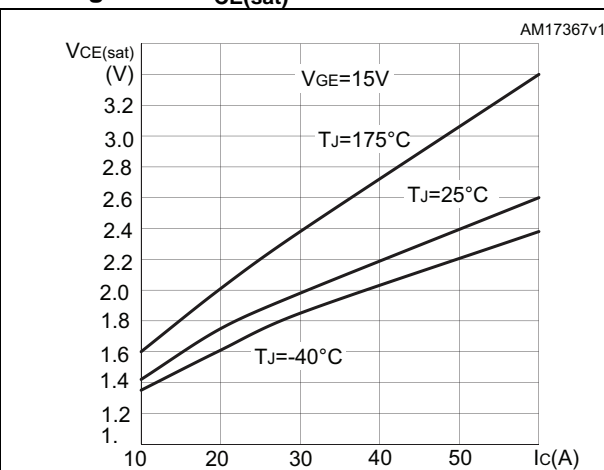

Figure 12. Collector current vs. case temperature for D²PAK, TO-220 and TO-247

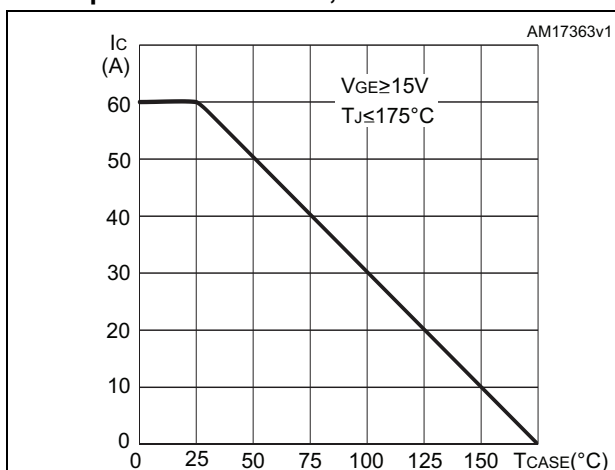

Figure 13. Collector current vs. case temperature for TO-220FP

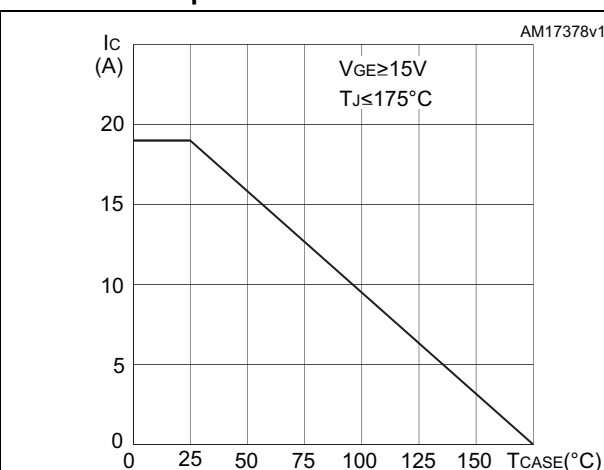

Figure 14. Forward bias safe operating area for TO-220, D²PAK and TO-247

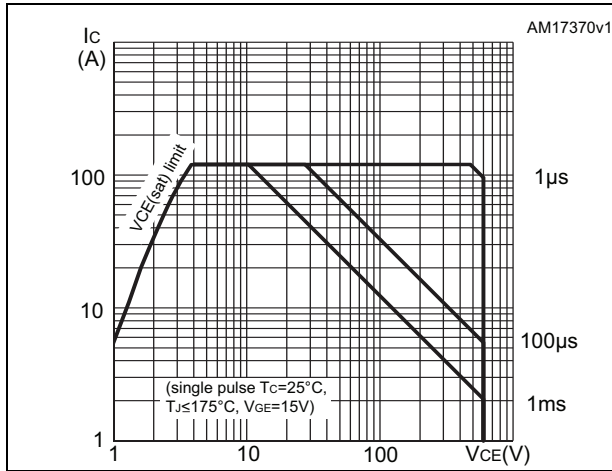

Figure 15. Thermal impedance for TO-220, D²PAK and TO-247

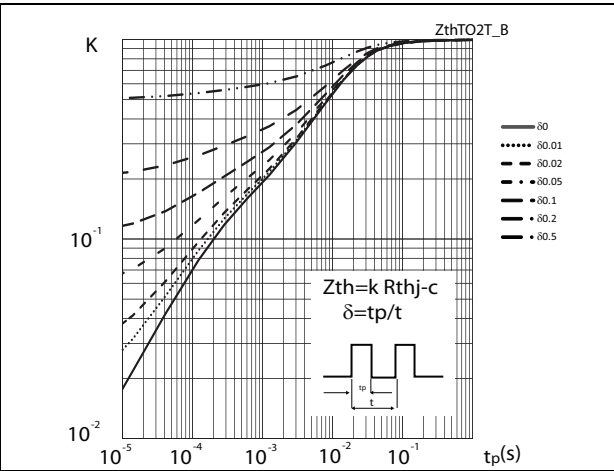

Figure 16. Forward bias safe operating area for TO-220FP

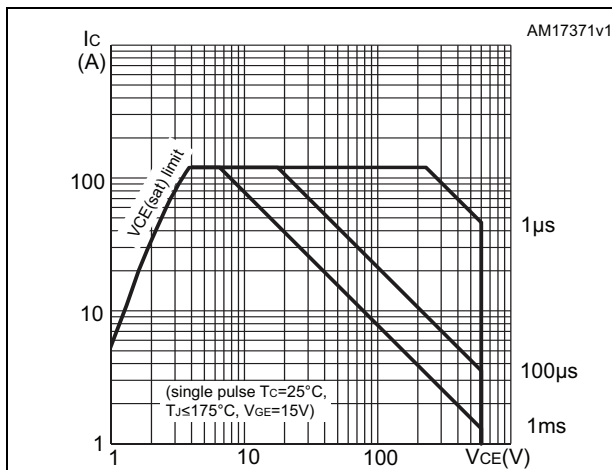

Figure 17. Thermal impedance for TO-220FP

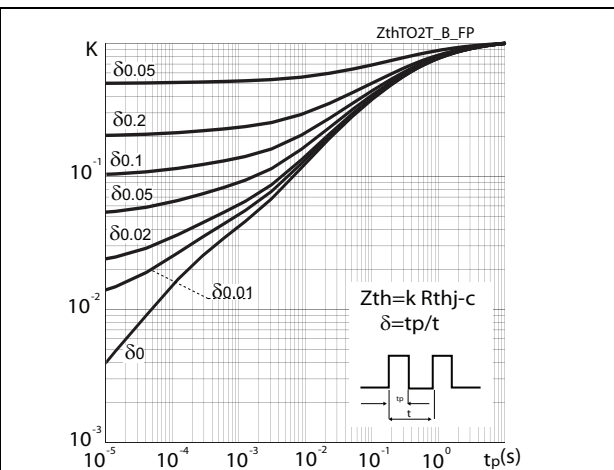

Figure 18. Gate charge vs. gate-emitter voltage

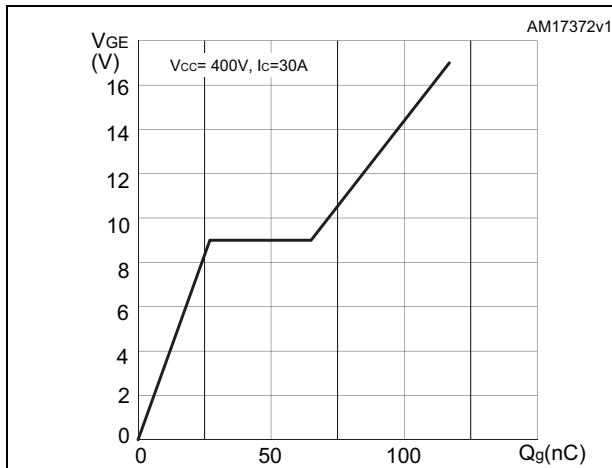

Figure 19. Capacitance variations vs. V_{CE}

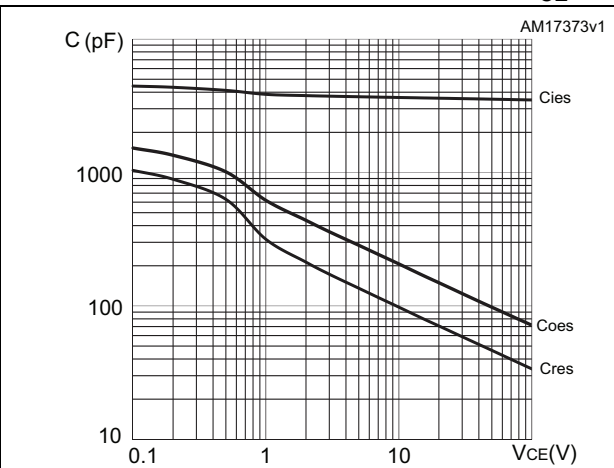

Figure 20. Diode VF vs. forward current

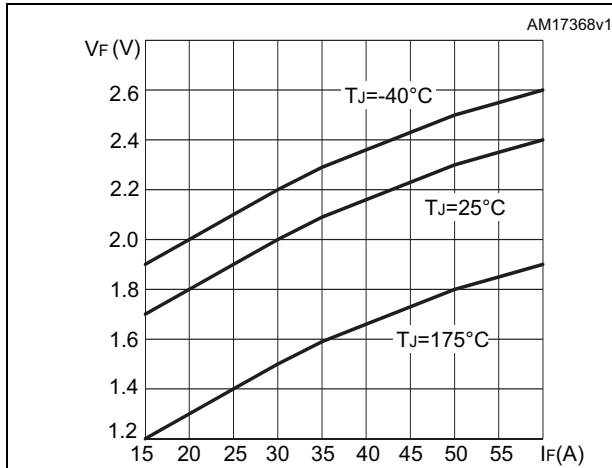

Figure 21. Switching losses vs. gate resistance

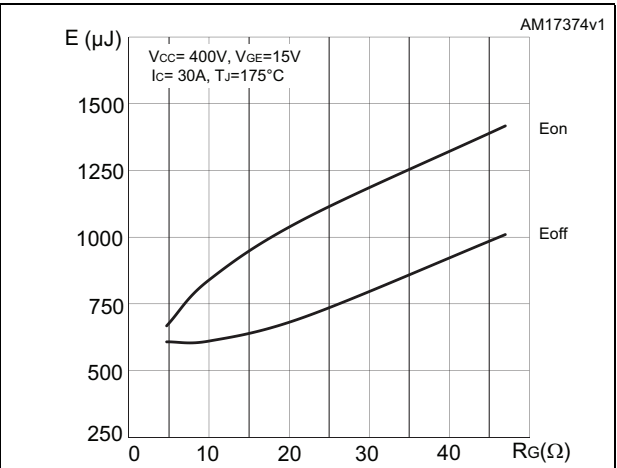

Figure 22. Switching losses vs. collector current

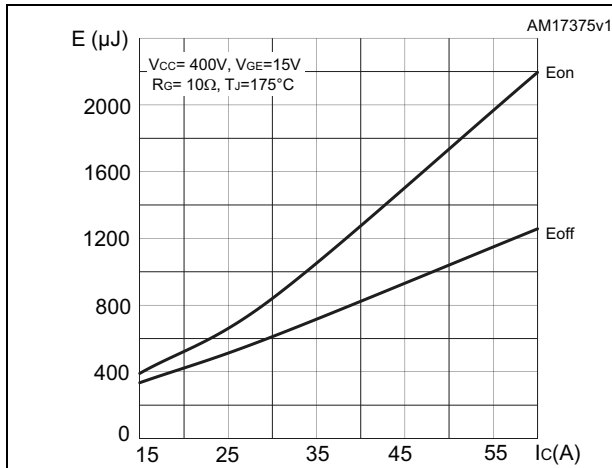

Figure 23. Switching losses vs temperature

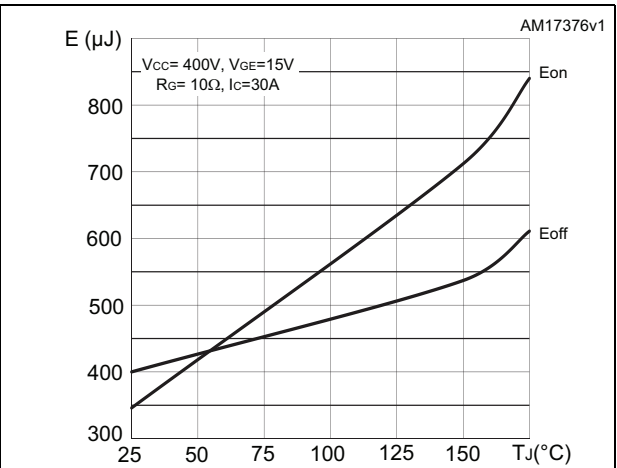
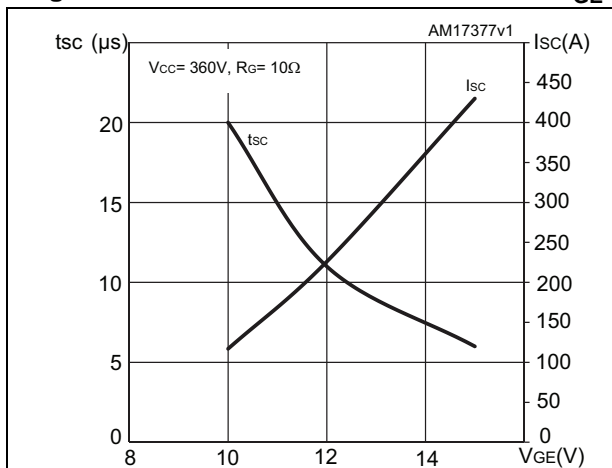
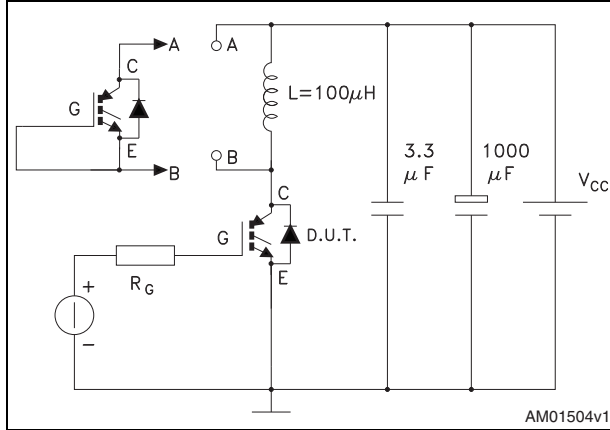

Figure 24. Short circuit time & current vs. VGE



3 Test circuits

Figure 25. Test circuit for inductive load switching



AM01504v1

Figure 26. Gate charge test circuit

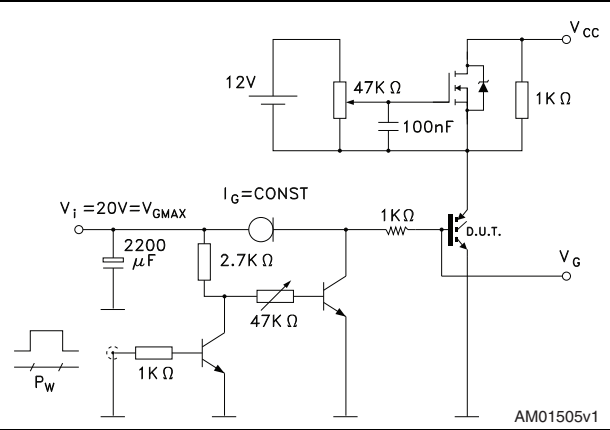

AM01505v1

Figure 27. Switching waveform

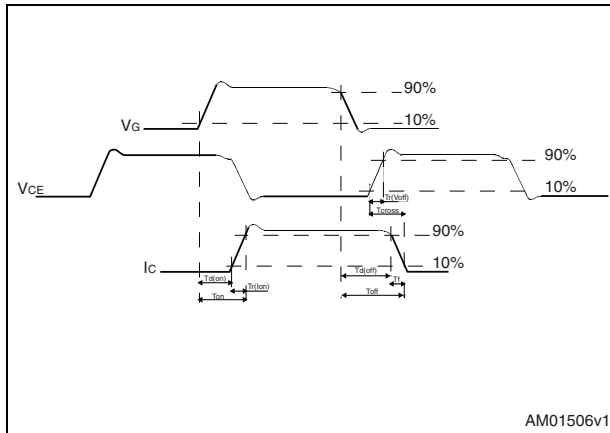

AM01506v1

Figure 28. Diode recovery time waveform

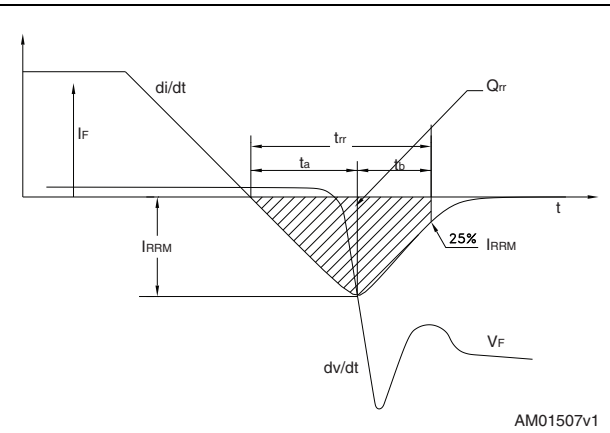

AM01507v1

4 Package mechanical data

In order to meet environmental requirements, ST offers these devices in different grades of ECOPACK[®] packages, depending on their level of environmental compliance. ECOPACK[®] specifications, grade definitions and product status are available at: www.st.com. ECOPACK[®] is an ST trademark.

Table 9. D²PAK (TO-263) mechanical data

Dim.	mm		
	Min.	Typ.	Max.
A	4.40		4.60
A1	0.03		0.23
b	0.70		0.93
b2	1.14		1.70
c	0.45		0.60
c2	1.23		1.36
D	8.95		9.35
D1	7.50		
E	10		10.40
E1	8.50		
e		2.54	
e1	4.88		5.28
H	15		15.85
J1	2.49		2.69
L	2.29		2.79
L1	1.27		1.40
L2	1.30		1.75
R		0.4	
V2	0°		8°

Figure 29. D²PAK (TO-263) drawing

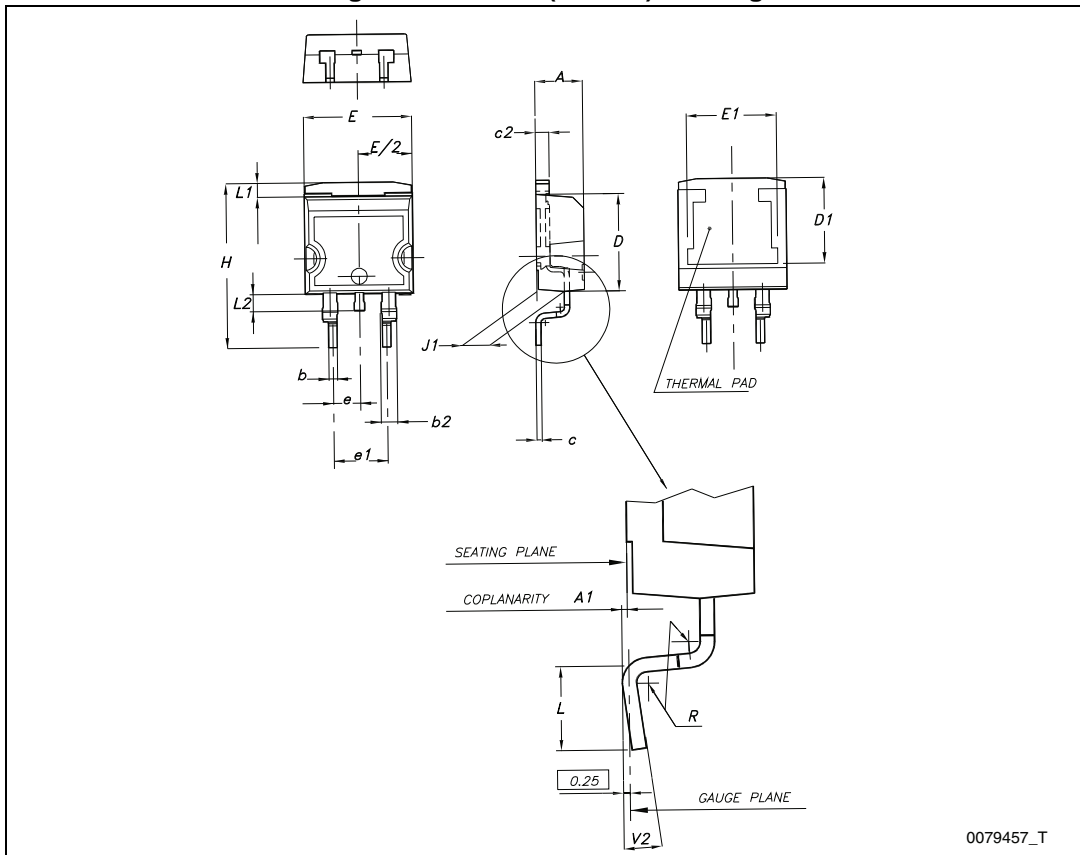

0079457_T

Table 10. TO-220FP mechanical data

Dim.	mm		
	Min.	Typ.	Max.
A	4.4		4.6
B	2.5		2.7
D	2.5		2.75
E	0.45		0.7
F	0.75		1
F1	1.15		1.70
F2	1.15		1.70
G	4.95		5.2
G1	2.4		2.7
H	10		10.4
L2		16	
L3	28.6		30.6
L4	9.8		10.6
L5	2.9		3.6
L6	15.9		16.4
L7	9		9.3
Dia	3		3.2

Figure 30. TO-220FP drawing

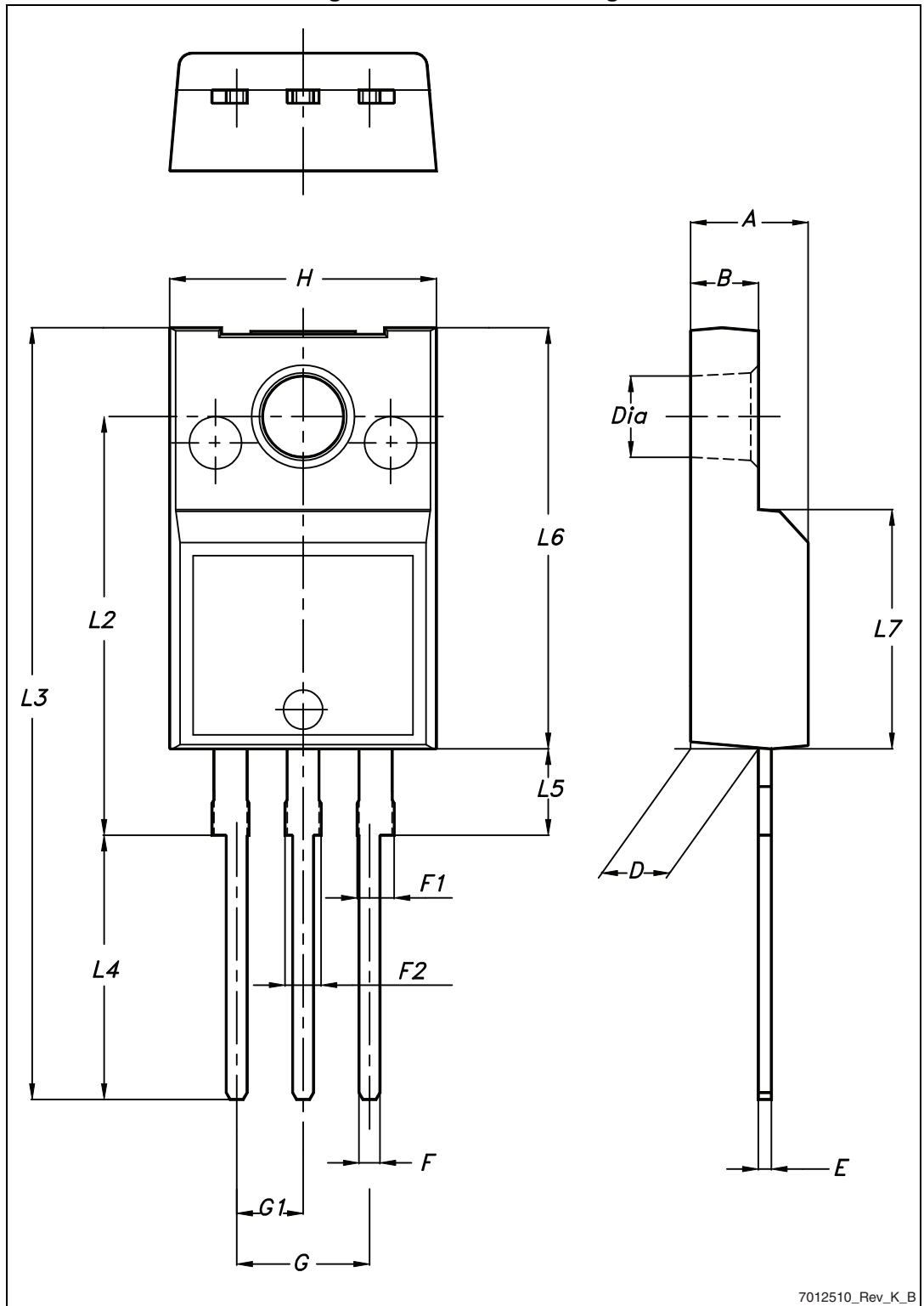

7012510_Rev_K_B

Table 11. TO-220 type A mechanical data

Dim.	mm		
	Min.	Typ.	Max.
A	4.40		4.60
b	0.61		0.88
b1	1.14		1.70
c	0.48		0.70
D	15.25		15.75
D1		1.27	
E	10		10.40
e	2.40		2.70
e1	4.95		5.15
F	1.23		1.32
H1	6.20		6.60
J1	2.40		2.72
L	13		14
L1	3.50		3.93
L20		16.40	
L30		28.90	
ØP	3.75		3.85
Q	2.65		2.95

Figure 31. TO-220 type A drawing

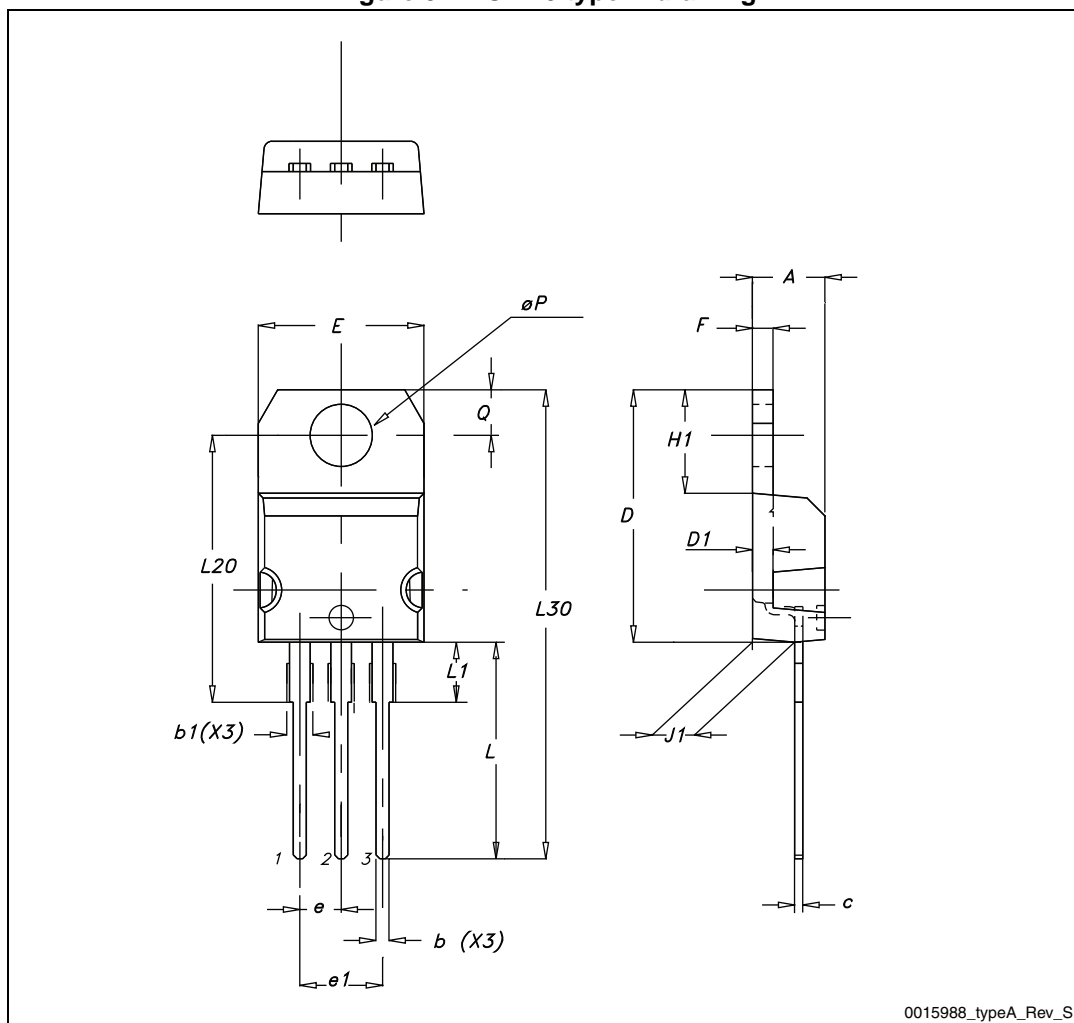
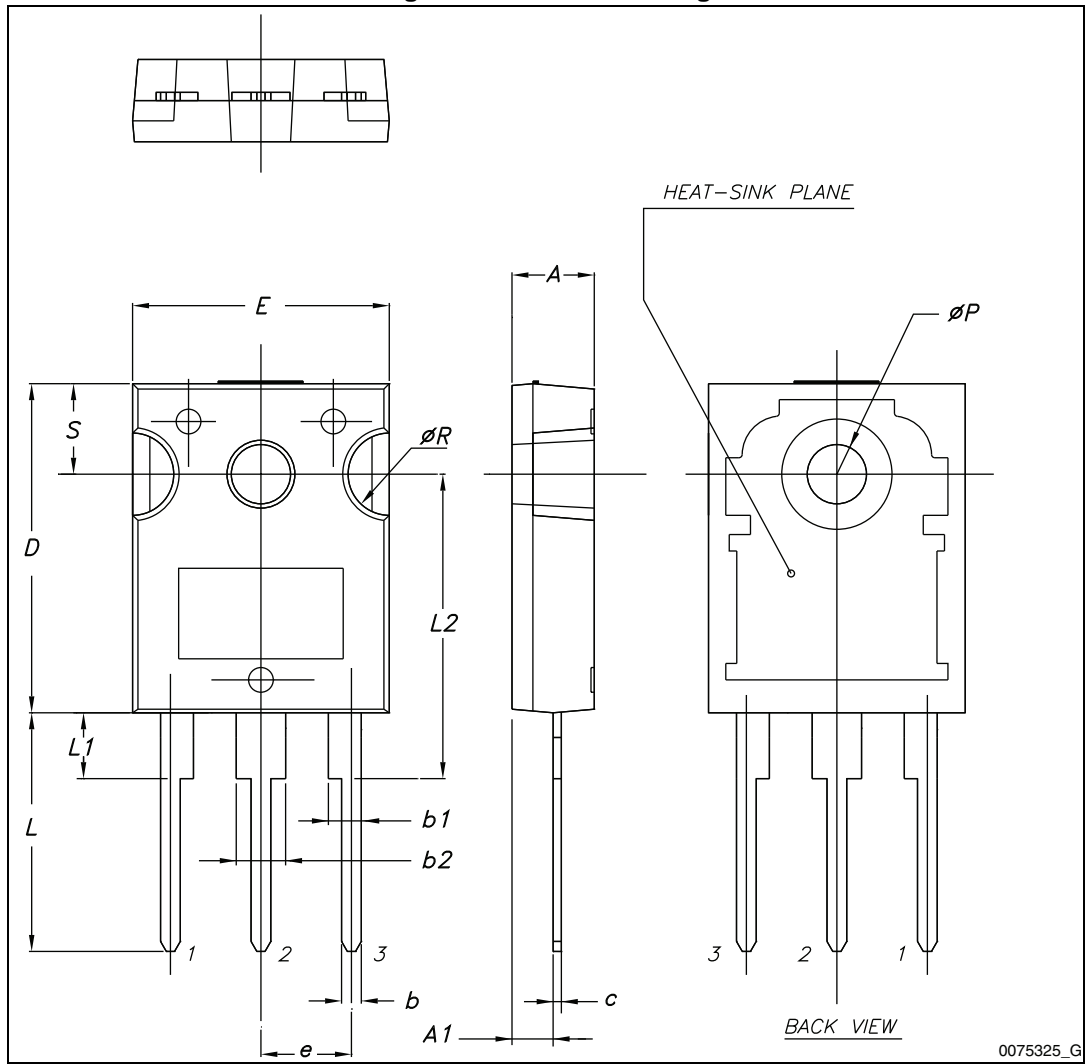

Table 12. TO-247 mechanical data

Dim.	mm.		
	Min.	Typ.	Max.
A	4.85		5.15
A1	2.20		2.60
b	1.0		1.40
b1	2.0		2.40
b2	3.0		3.40
c	0.40		0.80
D	19.85		20.15
E	15.45		15.75
e	5.30	5.45	5.60
L	14.20		14.80
L1	3.70		4.30
L2		18.50	
ØP	3.55		3.65
ØR	4.50		5.50
S	5.30	5.50	5.70

Figure 32. TO-247 drawing



5 Packaging mechanical data

Table 13. D²PAK (TO-263) tape and reel mechanical data

Tape			Reel		
Dim.	mm		Dim.	mm	
	Min.	Max.		Min.	Max.
A0	10.5	10.7	A		330
B0	15.7	15.9	B	1.5	
D	1.5	1.6	C	12.8	13.2
D1	1.59	1.61	D	20.2	
E	1.65	1.85	G	24.4	26.4
F	11.4	11.6	N	100	
K0	4.8	5.0	T		30.4
P0	3.9	4.1			
P1	11.9	12.1		Base qty	1000
P2	1.9	2.1		Bulk qty	1000
R	50				
T	0.25	0.35			
W	23.7	24.3			

Figure 33. D²PAK footprint^(a)

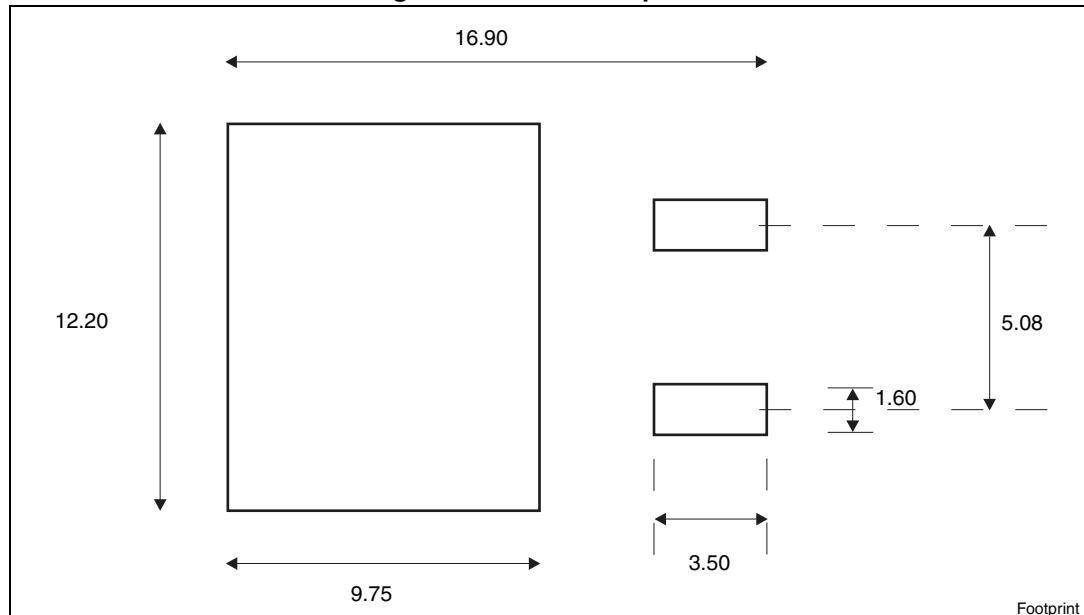
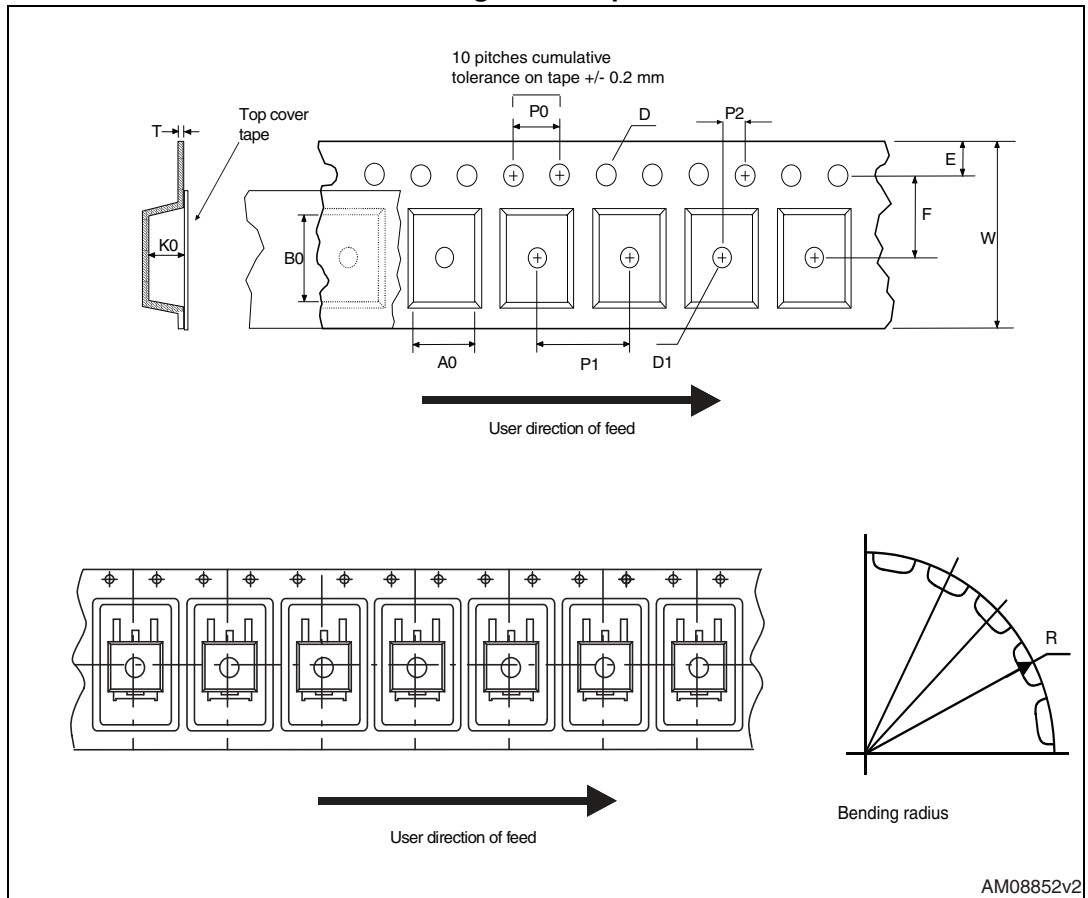
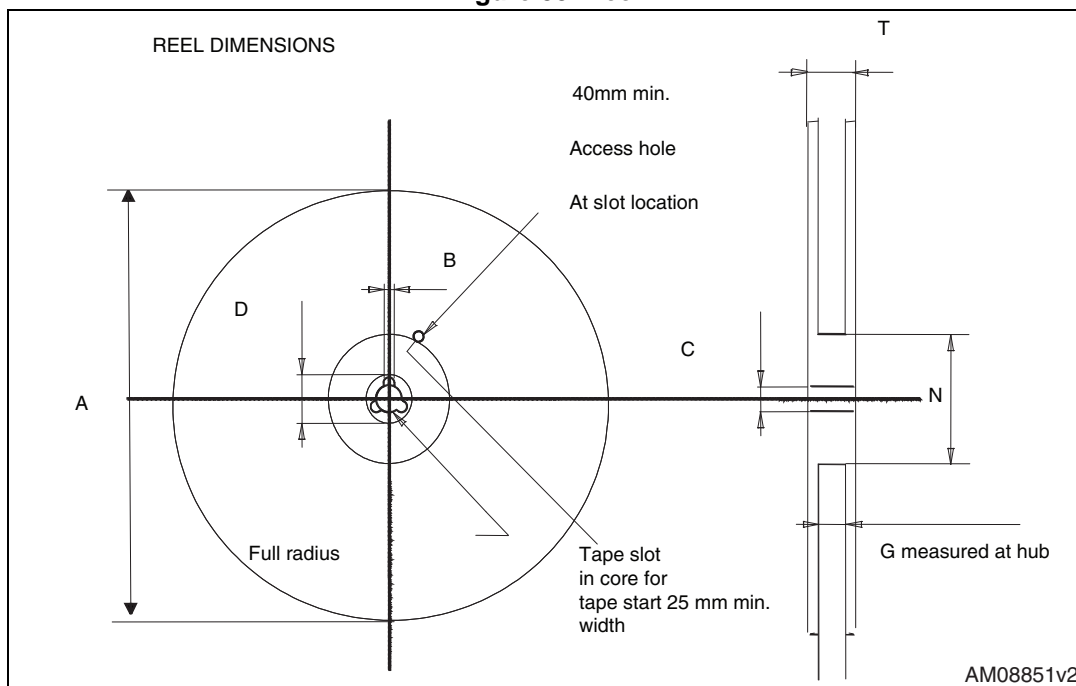

Figure 34. Tape



a. All dimensions are in millimeters

Figure 35. Reel



6 Revision history

Table 14. Document revision history

Date	Revision	Changes
14-Oct-2011	1	Initial release.
03-Oct-2012	2	Document status promoted from target specification to preliminary data.
20-Mar-2013	3	Document status promoted from preliminary data to production data. Added new root part number STGF30H60DF in TO-220FP package. Added new root part number STGW30H60DF in TO-247 package.

Please Read Carefully:

Information in this document is provided solely in connection with ST products. STMicroelectronics NV and its subsidiaries ("ST") reserve the right to make changes, corrections, modifications or improvements, to this document, and the products and services described herein at any time, without notice.

All ST products are sold pursuant to ST's terms and conditions of sale.

Purchasers are solely responsible for the choice, selection and use of the ST products and services described herein, and ST assumes no liability whatsoever relating to the choice, selection or use of the ST products and services described herein.

No license, express or implied, by estoppel or otherwise, to any intellectual property rights is granted under this document. If any part of this document refers to any third party products or services it shall not be deemed a license grant by ST for the use of such third party products or services, or any intellectual property contained therein or considered as a warranty covering the use in any manner whatsoever of such third party products or services or any intellectual property contained therein.

UNLESS OTHERWISE SET FORTH IN ST'S TERMS AND CONDITIONS OF SALE ST DISCLAIMS ANY EXPRESS OR IMPLIED WARRANTY WITH RESPECT TO THE USE AND/OR SALE OF ST PRODUCTS INCLUDING WITHOUT LIMITATION IMPLIED WARRANTIES OF MERCHANTABILITY, FITNESS FOR A PARTICULAR PURPOSE (AND THEIR EQUIVALENTS UNDER THE LAWS OF ANY JURISDICTION), OR INFRINGEMENT OF ANY PATENT, COPYRIGHT OR OTHER INTELLECTUAL PROPERTY RIGHT.

ST PRODUCTS ARE NOT AUTHORIZED FOR USE IN WEAPONS. NOR ARE ST PRODUCTS DESIGNED OR AUTHORIZED FOR USE IN: (A) SAFETY CRITICAL APPLICATIONS SUCH AS LIFE SUPPORTING, ACTIVE IMPLANTED DEVICES OR SYSTEMS WITH PRODUCT FUNCTIONAL SAFETY REQUIREMENTS; (B) AERONAUTIC APPLICATIONS; (C) AUTOMOTIVE APPLICATIONS OR ENVIRONMENTS, AND/OR (D) AEROSPACE APPLICATIONS OR ENVIRONMENTS. WHERE ST PRODUCTS ARE NOT DESIGNED FOR SUCH USE, THE PURCHASER SHALL USE PRODUCTS AT PURCHASER'S SOLE RISK, EVEN IF ST HAS BEEN INFORMED IN WRITING OF SUCH USAGE, UNLESS A PRODUCT IS EXPRESSLY DESIGNATED BY ST AS BEING INTENDED FOR "AUTOMOTIVE, AUTOMOTIVE SAFETY OR MEDICAL" INDUSTRY DOMAINS ACCORDING TO ST PRODUCT DESIGN SPECIFICATIONS. PRODUCTS FORMALLY ESCC, QML OR JAN QUALIFIED ARE DEEMED SUITABLE FOR USE IN AEROSPACE BY THE CORRESPONDING GOVERNMENTAL AGENCY.

Resale of ST products with provisions different from the statements and/or technical features set forth in this document shall immediately void any warranty granted by ST for the ST product or service described herein and shall not create or extend in any manner whatsoever, any liability of ST.

ST and the ST logo are trademarks or registered trademarks of ST in various countries.

Information in this document supersedes and replaces all information previously supplied.

The ST logo is a registered trademark of STMicroelectronics. All other names are the property of their respective owners.

© 2013 STMicroelectronics - All rights reserved

STMicroelectronics group of companies

Australia - Belgium - Brazil - Canada - China - Czech Republic - Finland - France - Germany - Hong Kong - India - Israel - Italy - Japan - Malaysia - Malta - Morocco - Philippines - Singapore - Spain - Sweden - Switzerland - United Kingdom - United States of America

www.st.com