

## SLLIMM™-nano (small low-loss intelligent molded module) IPM, 3 A - 600 V 3-phase IGBT inverter bridge

Datasheet – production data

### Features

- IPM 3 A, 600 V, 3-phase IGBT inverter bridge including control ICs for gate driving and freewheeling diodes
- Optimized for low electromagnetic interference
- $V_{CE(sat)}$  negative temperature coefficient
- 3.3 V, 5 V, 15 V CMOS/TTL inputs comparators with hysteresis and pull down/pull up resistors
- Undervoltage lockout
- Internal bootstrap diode
- Interlocking function
- Smart shutdown function
- Comparator for fault protection against overtemperature and overcurrent
- Op amp for advanced current sensing
- Optimized pinout for easy board layout

### Applications

- 3-phase inverters for motor drives
- Dish washers, refrigerator compressors, heating systems, air-conditioning fans, draining and recirculation pumps

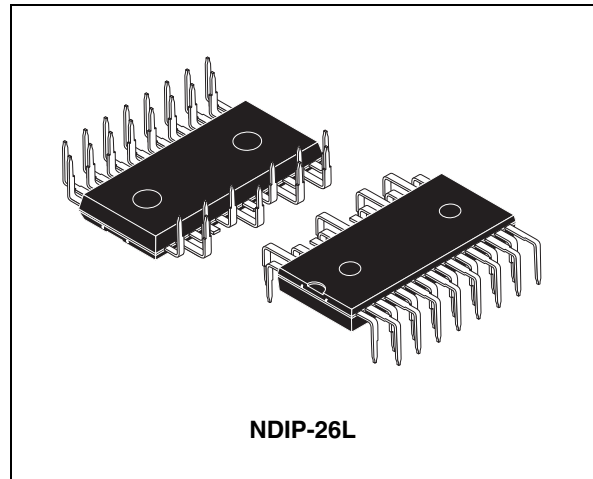

### Description

This intelligent power module implements a compact, high performance AC motor drive in a simple, rugged design. It is composed of six IGBTs with freewheeling diodes and three half-bridge HVICs for gate driving, providing low electromagnetic interference (EMI) characteristics with optimized switching speed. The package is optimized for thermal performance and compactness in built-in motor applications, or other low power applications where assembly space is limited. This IPM includes an operational amplifier, completely uncommitted, and a comparator that can be used to design a fast and efficient protection circuit. SLLIMM™ is a trademark of STMicroelectronics.

**Table 1. Device summary**

Order code	Marking	Package	Packaging
STGIPN3H60	GIPN3H60	NDIP-26L	Tube

# Contents

- 1 Internal schematic diagram and pin configuration ..... 3**
- 2 Electrical ratings ..... 6**
  - 2.1 Absolute maximum ratings ..... 6
  - 2.2 Thermal data ..... 7
- 3 Electrical characteristics ..... 8**
  - 3.1 Control part ..... 9
  - 3.2 Waveform definitions ..... 13
- 4 Smart shutdown function ..... 14**
- 5 Application information ..... 15**
  - 5.1 Recommendations ..... 16
- 6 Package mechanical data ..... 17**
- 7 Revision history ..... 20**

# 1 Internal schematic diagram and pin configuration

Figure 1. Internal schematic diagram

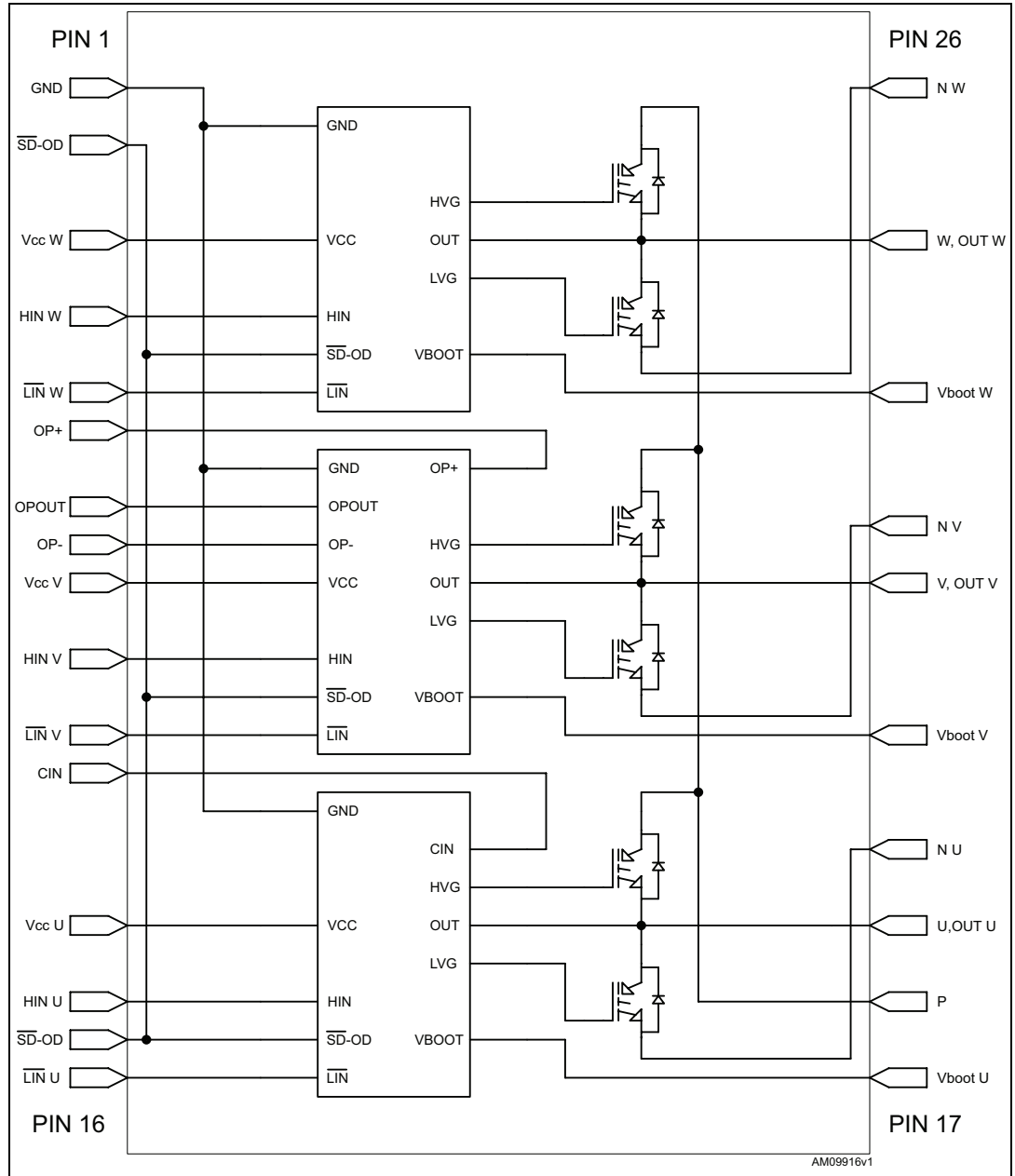
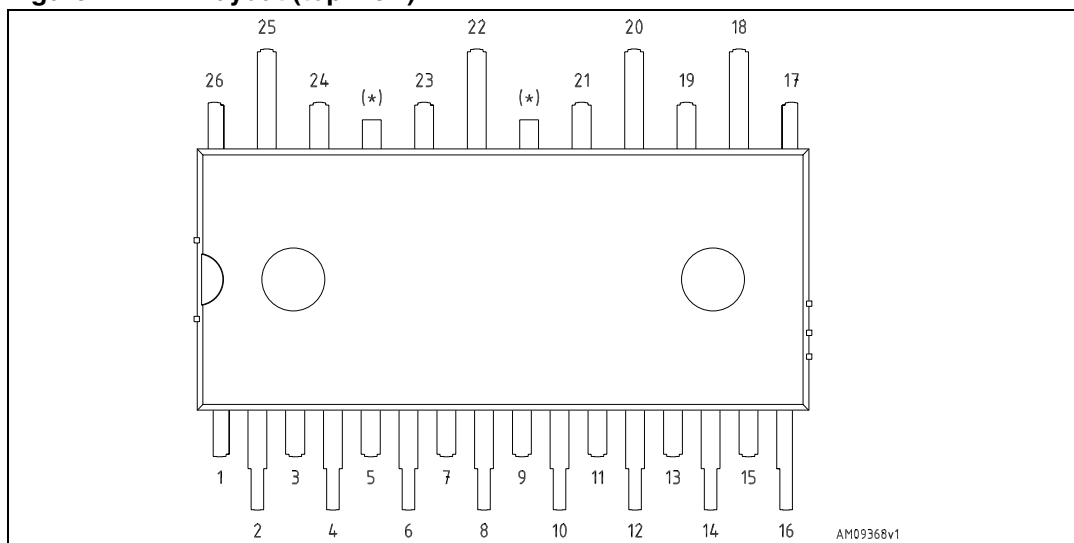

Table 2. Pin description

Pin	Symbol	Description
1	GND	Ground
2	$\overline{SD} / OD$	Shut down logic input (active low) / open drain (comparator output)
3	$V_{CC W}$	Low voltage power supply W phase
4	HIN W	High side logic input for W phase
5	$\overline{LIN W}$	Low side logic input for W phase
6	OP+	Op amp non inverting input
7	OP <sub>OUT</sub>	Op amp output
8	OP-	Op amp inverting input
9	$V_{CC V}$	Low voltage power supply V phase
10	HIN V	High side logic input for V phase
11	$\overline{LIN V}$	Low side logic input for V phase
12	CIN	Comparator input
13	$V_{CC U}$	Low voltage power supply for U phase
14	HIN U	High side logic input for U phase
15	$\overline{SD} / OD$	Shut down logic input (active low) / open drain (comparator output)
16	$\overline{LIN U}$	Low side logic input for U phase
17	$V_{BOOT U}$	Bootstrap voltage for U phase
18	P	Positive DC input
19	U, OUT <sub>U</sub>	U phase output
20	N <sub>U</sub>	Negative DC input for U phase
21	$V_{BOOT V}$	Bootstrap voltage for V phase
22	V, OUT <sub>V</sub>	V phase output
23	N <sub>V</sub>	Negative DC input for V phase
24	$V_{BOOT W}$	Bootstrap voltage for W phase
25	W, OUT <sub>W</sub>	W phase output
26	N <sub>W</sub>	Negative DC input for W phase

Figure 2. Pin layout (top view)



(\*) Dummy pin internally connected to P (positive DC input).

## 2 Electrical ratings

### 2.1 Absolute maximum ratings

**Table 3. Inverter part**

Symbol	Parameter	Value	Unit
$V_{CES}$	Each IGBT collector emitter voltage ( $V_{IN}^{(1)} = 0$ )	600	V
$\pm I_C^{(2)}$	Each IGBT continuous collector current at $T_C = 25^\circ\text{C}$	3	A
$\pm I_{CP}^{(3)}$	Each IGBT pulsed collector current	18	A
$P_{TOT}$	Each IGBT total dissipation at $T_C = 25^\circ\text{C}$	8	W

1. Applied between  $HIN_i$ ,  $\overline{LIN}_i$  and GND for  $i = U, V, W$
2. Calculated according to the iterative formula:

$$I_C(T_C) = \frac{T_{j(max)} - T_C}{R_{thj-c} \times V_{CE(sat)(max)}(T_{j(max)}, I_C(T_C))}$$

3. Pulse width limited by max junction temperature

**Table 4. Control part**

Symbol	Parameter	Min.	Max.	Unit
$V_{OUT}$	Output voltage applied between $OUT_U, OUT_V, OUT_W$ - GND	$V_{boot} - 21$	$V_{boot} + 0.3$	V
$V_{CC}$	Low voltage power supply	- 0.3	21	V
$V_{CIN}$	Comparator input voltage	- 0.3	$V_{CC} + 0.3$	V
$V_{op+}$	OPAMP non-inverting input	- 0.3	$V_{CC} + 0.3$	V
$V_{op-}$	OPAMP inverting input	- 0.3	$V_{CC} + 0.3$	V
$V_{boot}$	Bootstrap voltage	- 0.3	620	V
$V_{IN}$	Logic input voltage applied between $HIN, \overline{LIN}$ and GND	- 0.3	15	V
$V_{SD/OD}$	Open drain voltage	- 0.3	15	V
$\Delta V_{OUT}/dT$	Allowed output slew rate		50	V/ns

**Table 5. Total system**

Symbol	Parameter	Value	Unit
$V_{ISO}$	Isolation withstand voltage applied between each pin and heatsink plate (AC voltage, $t = 60$ sec.)	1000	V
$T_j$	Power chips operating junction temperature	-40 to 150	$^\circ\text{C}$
$T_C$	Module case operation temperature	-40 to 125	$^\circ\text{C}$

## 2.2 Thermal data

**Table 6. Thermal data**

Symbol	Parameter	Value	Unit
$R_{thJA}$	Thermal resistance junction-ambient	50	°C/W

### 3 Electrical characteristics

$T_J = 25\text{ }^\circ\text{C}$  unless otherwise specified.

**Table 7. Inverter part**

Symbol	Parameter	Test conditions	Min.	Typ.	Max.	Unit
$V_{CE(sat)}$	Collector-emitter saturation voltage	$V_{CC} = V_{boot} = 15\text{ V}$ , $V_{IN}^{(1)} = 0 - 5\text{ V}$ , $I_C = 1\text{ A}$	-	2.15	2.6	V
		$V_{CC} = V_{boot} = 15\text{ V}$ , $V_{IN}^{(1)} = 0 - 5\text{ V}$ , $I_C = 1\text{ A}$ , $T_J = 125\text{ }^\circ\text{C}$	-	1.65		
$I_{CES}$	Collector-cut off current ( $V_{IN}^{(1)} = 0$ "logic state")	$V_{CE} = 550\text{ V}$ , $V_{CC} = V_{Boot} = 15\text{ V}$	-		250	$\mu\text{A}$
$V_F$	Diode forward voltage	$V_{IN}^{(1)} = 0$ "logic state", $I_C = 1\text{ A}$	-		1.7	V
<b>Inductive load switching time and energy</b>						
$t_{on}$	Turn-on time	$V_{DD} = 300\text{ V}$ , $V_{CC} = V_{boot} = 15\text{ V}$ , $V_{IN}^{(1)} = 0 - 5\text{ V}$ , $I_C = 1\text{ A}$ (see <a href="#">Figure 4</a> )	-	275		ns
$t_{c(on)}$	Crossover time (on)		-	90		
$t_{off}$	Turn-off time		-	890		
$t_{c(off)}$	Crossover time (off)		-	125		
$t_{rr}$	Reverse recovery time		-	50		$\mu\text{J}$
$E_{on}$	Turn-on switching losses		-	18		
$E_{off}$	Turn-off switching losses		-	13		

1. Applied between  $HIN_i$ ,  $\overline{LIN}_i$  and GND for  $i = U, V, W$  ( $\overline{LIN}$  inputs are active-low).

*Note:*  $t_{ON}$  and  $t_{OFF}$  include the propagation delay time of the internal drive.  $t_{C(ON)}$  and  $t_{C(OFF)}$  are the switching time of IGBT itself under the internally given gate driving condition.

**Figure 3. Switching time test circuit**

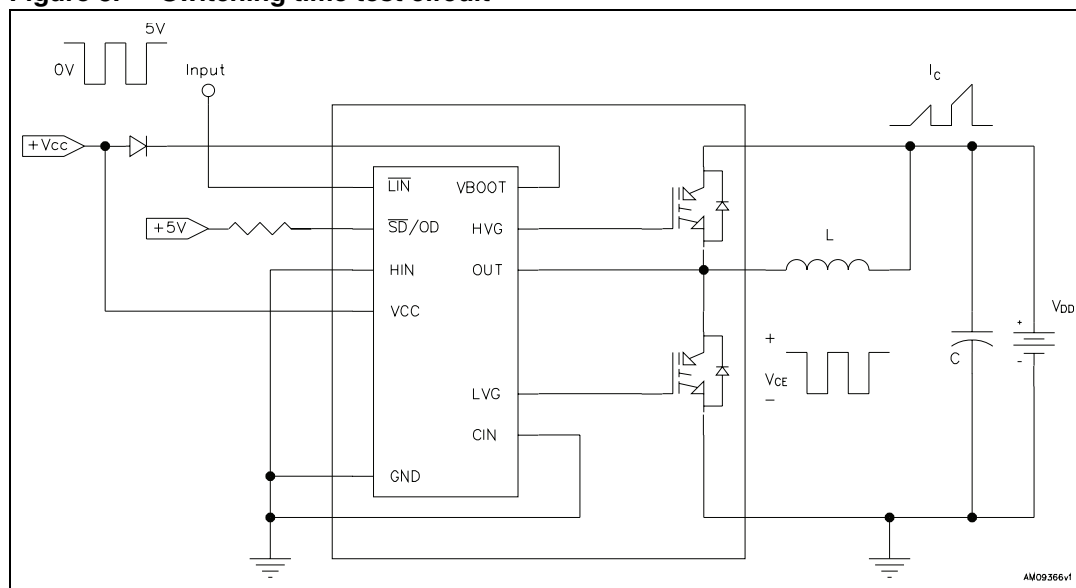
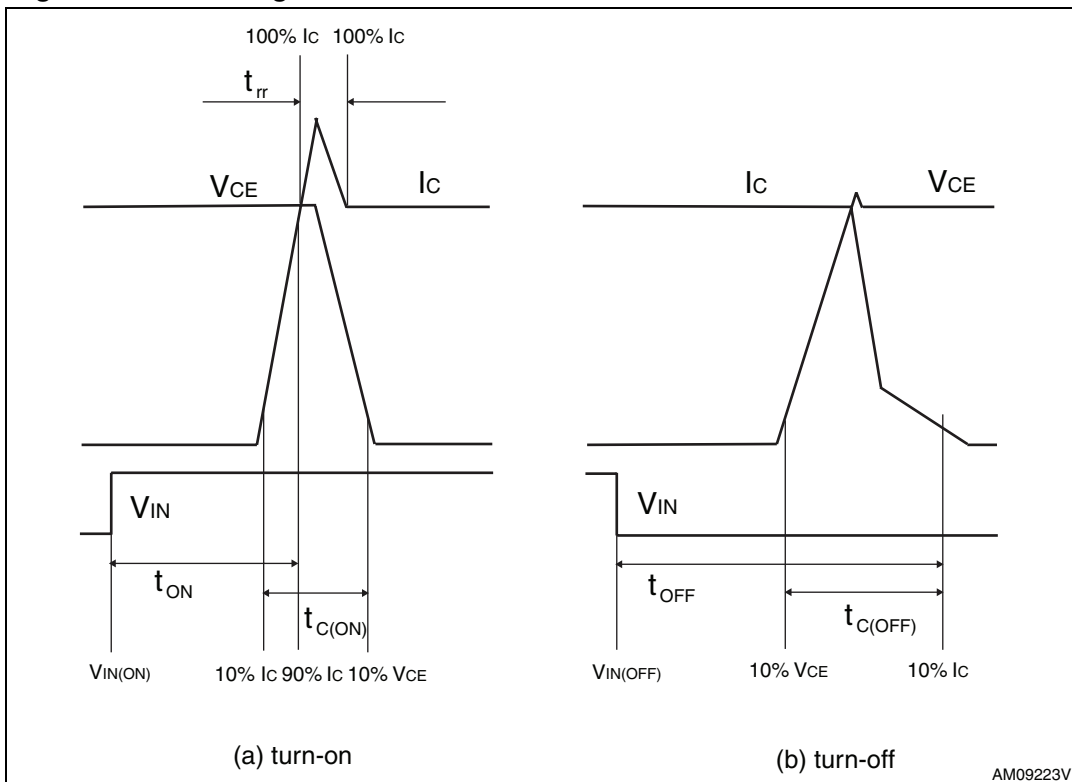



Figure 4. Switching time definition



Note: Figure 4 “Switching time definition” refers to HIN inputs (active high). For  $\overline{LIN}$  inputs (active low), VIN polarity must be inverted for turn-on and turn-off.

### 3.1 Control part

Table 8. Low voltage power supply (VCC = 15 V unless otherwise specified)

Symbol	Parameter	Test conditions	Min.	Typ.	Max.	Unit
V <sub>CC_hys</sub>	V <sub>CC</sub> UV hysteresis		1.2	1.5	1.8	V
V <sub>CC_thON</sub>	V <sub>CC</sub> UV turn ON threshold		11.5	12	12.5	V
V <sub>CC_thOFF</sub>	V <sub>CC</sub> UV turn OFF threshold		10	10.5	11	V
I <sub>qccu</sub>	Undervoltage quiescent supply current	V <sub>CC</sub> = 10 V $\overline{SD}/OD = 5$ V; $\overline{LIN} = 5$ V; HIN = 0, CIN = 0			150	μA
I <sub>qcc</sub>	Quiescent current	V <sub>CC</sub> = 15 V $\overline{SD}/OD = 5$ V; $\overline{LIN} = 5$ V HIN = 0, CIN = 0			1	mA
V <sub>ref</sub>	Internal comparator (CIN) reference voltage		0.5	0.54	0.58	V

**Table 9. Bootstrapped voltage ( $V_{CC} = 15\text{ V}$  unless otherwise specified)**

Symbol	Parameter	Test conditions	Min.	Typ.	Max.	Unit
$V_{BS\_hys}$	$V_{BS}$ UV hysteresis		1.2	1.5	1.8	V
$V_{BS\_thON}$	$V_{BS}$ UV turn ON threshold		10.6	11.5	12.4	V
$V_{BS\_thOFF}$	$V_{BS}$ UV turn OFF threshold		9.1	10	10.9	V
$I_{QBSU}$	Undervoltage $V_{BS}$ quiescent current	$V_{BS} < 9\text{ V}$ $\overline{SD}/OD = 5\text{ V}$ ; $\overline{LIN}$ and $HIN = 5\text{ V}$ ; $CIN = 0$		70	110	$\mu\text{A}$
$I_{QBS}$	$V_{BS}$ quiescent current	$V_{BS} = 15\text{ V}$ $\overline{SD}/OD = 5\text{ V}$ ; $\overline{LIN}$ and $HIN = 5\text{ V}$ ; $CIN = 0$		150	210	$\mu\text{A}$
$R_{DS(on)}$	Bootstrap driver on resistance	LVG ON		120		$\Omega$

**Table 10. Logic inputs ( $V_{CC} = 15\text{ V}$  unless otherwise specified)**

Symbol	Parameter	Test conditions	Min.	Typ.	Max.	Unit
$V_{il}$	Low logic level voltage				0.8	V
$V_{ih}$	High logic level voltage		2.25			V
$I_{HINh}$	HIN logic "1" input bias current	$HIN = 15\text{ V}$	110	175	260	$\mu\text{A}$
$I_{HINl}$	HIN logic "0" input bias current	$HIN = 0\text{ V}$			1	$\mu\text{A}$
$I_{LINl}$	$\overline{LIN}$ logic "1" input bias current	$\overline{LIN} = 0\text{ V}$	3	6	20	$\mu\text{A}$
$I_{LINh}$	$\overline{LIN}$ logic "0" input bias current	$\overline{LIN} = 15\text{ V}$			1	$\mu\text{A}$
$I_{SDh}$	$\overline{SD}$ logic "0" input bias current	$\overline{SD} = 15\text{ V}$	30	120	300	$\mu\text{A}$
$I_{SDl}$	$\overline{SD}$ logic "1" input bias current	$\overline{SD} = 0\text{ V}$			3	$\mu\text{A}$
Dt	Dead time	see <a href="#">Figure 5</a>		180		ns

Table 11. OPAMP characteristics ( $V_{CC} = 15\text{ V}$  unless otherwise specified)

Symbol	Parameter	Test condition	Min.	Typ.	Max.	Unit
$V_{io}$	Input offset voltage	$V_{ic} = 0\text{ V}$ , $V_o = 7.5\text{ V}$			6	mV
$I_{io}$	Input offset current	$V_{ic} = 0\text{ V}$ , $V_o = 7.5\text{ V}$		4	40	nA
$I_{ib}$	Input bias current <sup>(1)</sup>			100	200	nA
$V_{icm}$	Input common mode voltage range		0			V
$V_{OL}$	Low level output voltage	$R_L = 10\text{ k}\Omega$ to $V_{CC}$		75	150	mV
$V_{OH}$	High level output voltage	$R_L = 10\text{ k}\Omega$ to GND	14	14.7		V
$I_o$	Output short circuit current	Source, $V_{id} = +1$ ; $V_o = 0\text{ V}$	16	30		mA
		Sink, $V_{id} = -1$ ; $V_o = V_{CC}$	50	80		mA
SR	Slew rate	$V_i = 1 - 4\text{ V}$ ; $C_L = 100\text{ pF}$ ; unity gain	2.5	3.8		V/ $\mu\text{s}$
GBWP	Gain bandwidth product	$V_o = 7.5\text{ V}$	8	12		MHz
$A_{vd}$	Large signal voltage gain	$R_L = 2\text{ k}\Omega$	70	85		dB
SVR	Supply voltage rejection ratio	vs. $V_{CC}$	60	75		dB
CMRR	Common mode rejection ratio		55	70		dB

1. The direction of input current is out of the IC.

Table 12. Sense comparator characteristics ( $V_{CC} = 15\text{ V}$  unless otherwise specified)

Symbol	Parameter	Test conditions	Min.	Typ.	Max.	Unit
$I_{ib}$	Input bias current	$V_{CP+} = 1\text{ V}$			3	$\mu\text{A}$
$V_{ol}$	Open drain low level output voltage	$I_{od} = 3\text{ mA}$			0.5	V
$t_{d\_comp}$	Comparator delay	$\overline{SD}/OD$ pulled to 5 V through 100 k $\Omega$ resistor		90	130	ns
SR	Slew rate	$C_L = 180\text{ pF}$ ; $R_{pu} = 5\text{ k}\Omega$		60		V/ $\mu\text{sec}$
$t_{sd}$	Shutdown to high / low side driver propagation delay	$V_{OUT} = 0$ , $V_{boot} = V_{CC}$ ; $V_{IN} = 0$ to 3.3 V	50	125	200	ns
$t_{isd}$	Comparator triggering to high / low side driver turn-off propagation delay	Measured applying a voltage step from 0 V to 3.3 V to pin $CIN_i$	50	200	250	

Table 13. Truth table

Condition	Logic input (V <sub>I</sub> )			Output	
	$\overline{\text{SD/OD}}$	$\overline{\text{LIN}}$	HIN	LVG	HVG
Shutdown enable half-bridge tri-state	L	X	X	L	L
Interlocking half-bridge tri-state	H	L	H	L	L
0 "logic state" half-bridge tri-state	H	H	L	L	L
1 "logic state" low side direct driving	H	L	L	H	L
1 "logic state" high side direct driving	H	H	H	L	H

Note: X: don't care

### 3.2 Waveform definitions

Figure 5. Dead time and interlocking waveform definitions

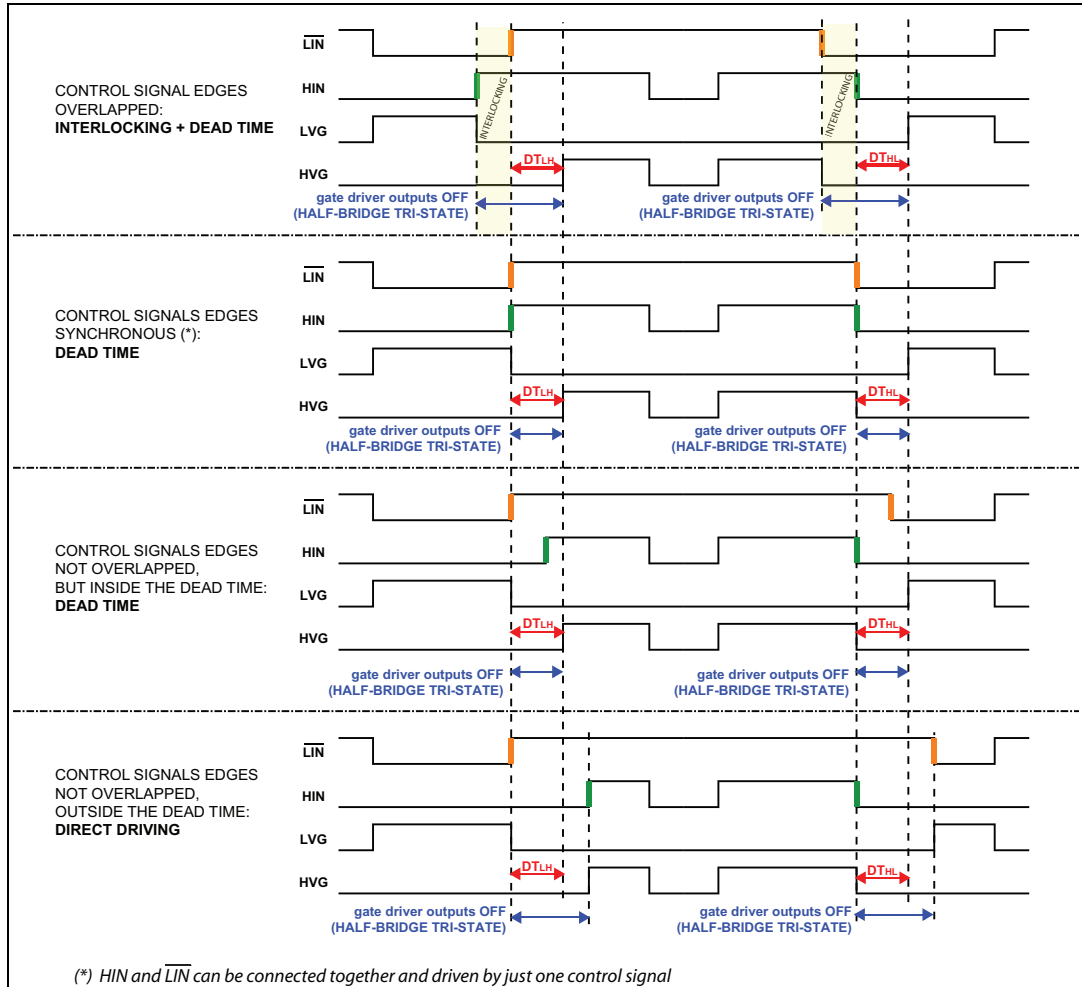

## 4 Smart shutdown function

The STGIPN3H60 integrates a comparator for fault sensing purposes. The comparator non-inverting input (CIN) can be connected to an external shunt resistor in order to implement a simple overcurrent protection function. When the comparator triggers, the device is set in shutdown state and both its outputs are set to low-level leading the half bridge in 3-state. In the common overcurrent protection architectures the comparator output is usually connected to the shutdown input through a RC network, in order to provide a mono-stable circuit, which implements a protection time that follows the fault condition. Our smart shutdown architecture allows to immediately turn-off the output gate driver in case of overcurrent, the fault signal has a preferential path which directly switches off the outputs. The time delay between the fault and the outputs turn-off is no more dependent on the RC values of the external network connected to the shutdown pin. At the same time the internal logic turns on the open-drain output and holds it on until the shutdown voltage goes below the logic input lower threshold. Finally the smart shutdown function provides the possibility to increase the real disable time without increasing the constant time of the external RC network.

Figure 6. Smart shutdown timing waveforms

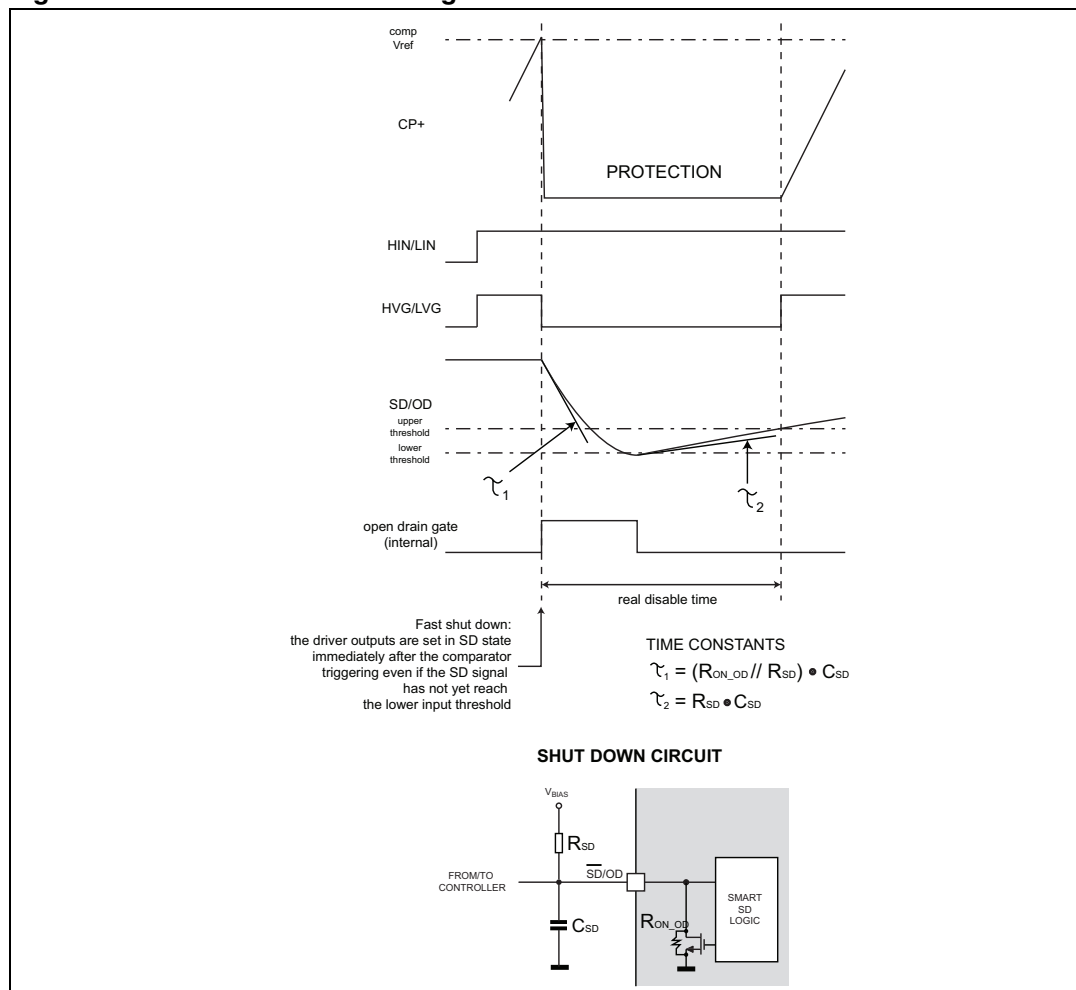

Please refer to [Table 12](#) for internal propagation delay time details.



## 5.1 Recommendations

- Input signal HIN is active high logic. An 85 k $\Omega$  (typ.) pull-down resistor is built-in for each high side input. If an external RC filter is used for noise immunity, attention should be given to the variation of the input signal level.
- Input signal  $\overline{\text{LIN}}$  is active low logic. A 720 k $\Omega$  (typ.) pull-up resistor, connected to an internal 5 V regulator through a diode, is built-in for each low side input.
- To prevent input signal oscillation, the wiring of each input should be as short as possible.
- By integrating an application-specific type HVIC inside the module, direct coupling to the MCU terminals without an opto-coupler is possible.
- Each capacitor should be located as close as possible to the pins of the IPM.
- Low inductance shunt resistors should be used for phase leg current sensing.
- Electrolytic bus capacitors should be mounted as close to the module bus terminals as possible. Additional high frequency ceramic capacitors mounted close to the module pins will further improve performance.
- The  $\overline{\text{SD}}/\text{OD}$  signal should be pulled up to 5 V / 3.3 V with an external resistor (see [Section 4: Smart shutdown function](#) for detailed info).

**Table 14. Recommended operating conditions**

Symbol	Parameter	Test conditions	Min.	Typ.	Max.	Unit
$V_{PN}$	Supply voltage	Applied between P-Nu, Nv, Nw		300	500	V
$V_{CC}$	Control supply voltage	Applied between $V_{CC}$ -GND	13.5	15	18	V
$V_{BS}$	High side bias voltage	Applied between $V_{BOOTi}$ - $\text{OUT}_i$ for $i = U, V, W$	13		18	V
$t_{\text{dead}}$	Blanking time to prevent Arm-short	For each input signal	1.5			$\mu\text{s}$
$f_{\text{PWM}}$	PWM input signal	$-40^\circ\text{C} < T_c < 100^\circ\text{C}$ $-40^\circ\text{C} < T_j < 125^\circ\text{C}$			25	kHz
$T_C$	Case operation temperature				100	$^\circ\text{C}$

Note: For further details refer to AN4043.



## 6 Package mechanical data

In order to meet environmental requirements, ST offers these devices in different grades of ECOPACK® packages, depending on their level of environmental compliance. ECOPACK® specifications, grade definitions and product status are available at: [www.st.com](http://www.st.com). ECOPACK® is an ST trademark.

**Table 15. NDIP-26L mechanical data**

Dim.	mm.		
	Min.	Typ.	Max.
A			4.40
A1	0.80	1.00	1.20
A2	3.00	3.10	3.20
A3	1.70	1.80	1.90
A4	5.70	5.90	6.10
b	0.53		0.72
b1	0.52	0.60	0.68
b2	0.83		1.02
b3	0.82	0.90	0.98
c	0.46		0.59
c1	0.45	0.50	0.55
D	29.05	29.15	29.25
D1	0.50		
D2	0.35		
D3			29.55
E	12.35	12.45	12.55
e	1.70	1.80	1.90
e1	2.40	2.50	2.60
eB1	16.10	16.40	16.70
eB2	21.18	21.48	21.78
L	1.24	1.39	1.54

Figure 8. NDIP-26L package dimensions

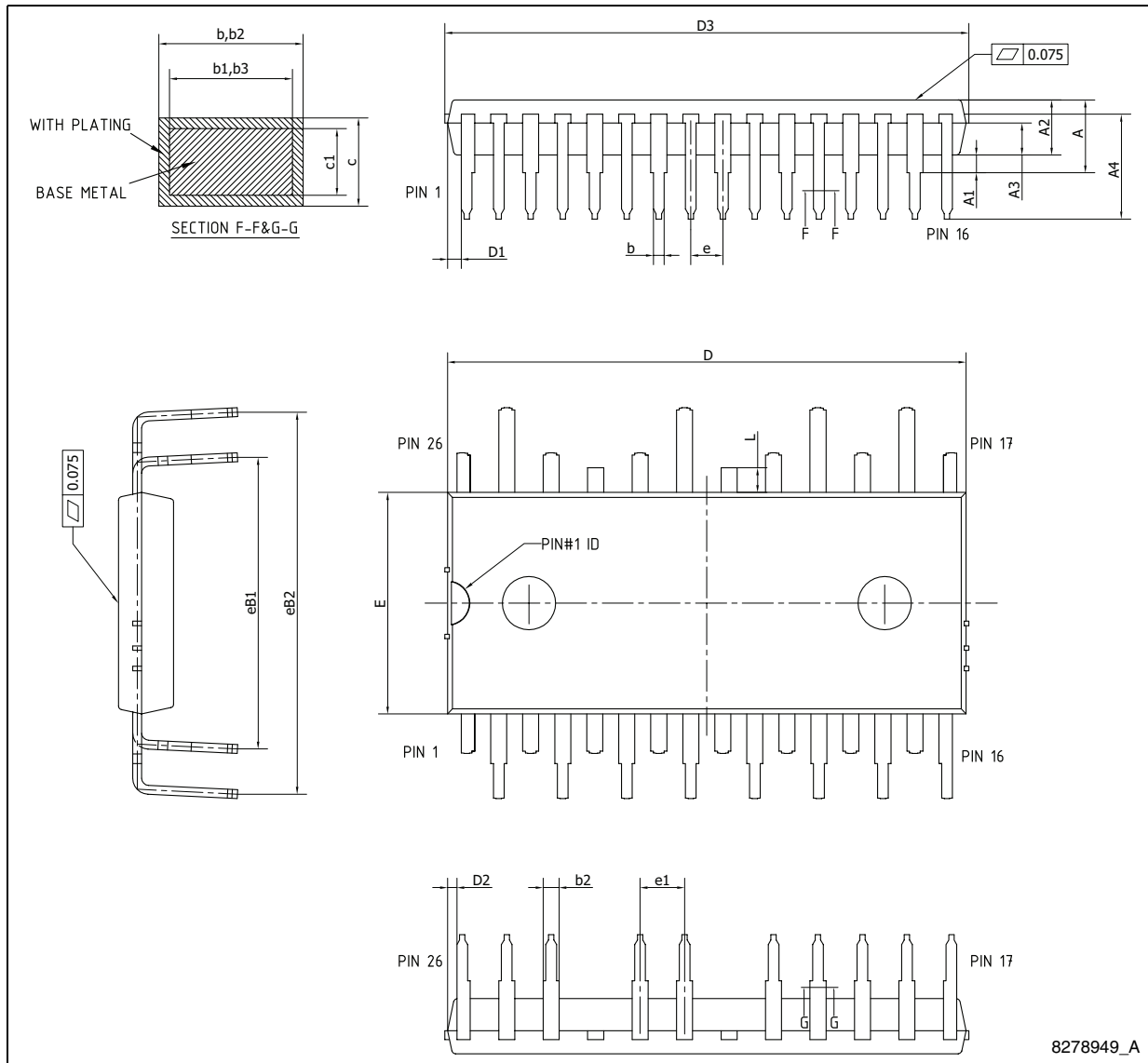



## 7 Revision history

**Table 16. Document revision history**

Date	Revision	Changes
23-Jun-2011	1	Initial release.
23-Dec-2011	2	Document status promoted from preliminary data to datasheet. Added <a href="#">Figure 9 on page 19</a> .
02-May-2012	3	Modified: Min. and Max. value <a href="#">Table 4 on page 6</a> . Added: <a href="#">Table 14 on page 16</a> .

**Please Read Carefully:**

Information in this document is provided solely in connection with ST products. STMicroelectronics NV and its subsidiaries ("ST") reserve the right to make changes, corrections, modifications or improvements, to this document, and the products and services described herein at any time, without notice.

All ST products are sold pursuant to ST's terms and conditions of sale.

Purchasers are solely responsible for the choice, selection and use of the ST products and services described herein, and ST assumes no liability whatsoever relating to the choice, selection or use of the ST products and services described herein.

No license, express or implied, by estoppel or otherwise, to any intellectual property rights is granted under this document. If any part of this document refers to any third party products or services it shall not be deemed a license grant by ST for the use of such third party products or services, or any intellectual property contained therein or considered as a warranty covering the use in any manner whatsoever of such third party products or services or any intellectual property contained therein.

**UNLESS OTHERWISE SET FORTH IN ST'S TERMS AND CONDITIONS OF SALE ST DISCLAIMS ANY EXPRESS OR IMPLIED WARRANTY WITH RESPECT TO THE USE AND/OR SALE OF ST PRODUCTS INCLUDING WITHOUT LIMITATION IMPLIED WARRANTIES OF MERCHANTABILITY, FITNESS FOR A PARTICULAR PURPOSE (AND THEIR EQUIVALENTS UNDER THE LAWS OF ANY JURISDICTION), OR INFRINGEMENT OF ANY PATENT, COPYRIGHT OR OTHER INTELLECTUAL PROPERTY RIGHT.**

**UNLESS EXPRESSLY APPROVED IN WRITING BY TWO AUTHORIZED ST REPRESENTATIVES, ST PRODUCTS ARE NOT RECOMMENDED, AUTHORIZED OR WARRANTED FOR USE IN MILITARY, AIR CRAFT, SPACE, LIFE SAVING, OR LIFE SUSTAINING APPLICATIONS, NOR IN PRODUCTS OR SYSTEMS WHERE FAILURE OR MALFUNCTION MAY RESULT IN PERSONAL INJURY, DEATH, OR SEVERE PROPERTY OR ENVIRONMENTAL DAMAGE. ST PRODUCTS WHICH ARE NOT SPECIFIED AS "AUTOMOTIVE GRADE" MAY ONLY BE USED IN AUTOMOTIVE APPLICATIONS AT USER'S OWN RISK.**

Resale of ST products with provisions different from the statements and/or technical features set forth in this document shall immediately void any warranty granted by ST for the ST product or service described herein and shall not create or extend in any manner whatsoever, any liability of ST.

ST and the ST logo are trademarks or registered trademarks of ST in various countries.

Information in this document supersedes and replaces all information previously supplied.

The ST logo is a registered trademark of STMicroelectronics. All other names are the property of their respective owners.

© 2012 STMicroelectronics - All rights reserved

STMicroelectronics group of companies

Australia - Belgium - Brazil - Canada - China - Czech Republic - Finland - France - Germany - Hong Kong - India - Israel - Italy - Japan - Malaysia - Malta - Morocco - Philippines - Singapore - Spain - Sweden - Switzerland - United Kingdom - United States of America

[www.st.com](http://www.st.com)

