

## SLLIMM™ - 2<sup>nd</sup> series IPM, 3-phase inverter, 8 A, 600 V short-circuit rugged IGBTs

Datasheet - production data

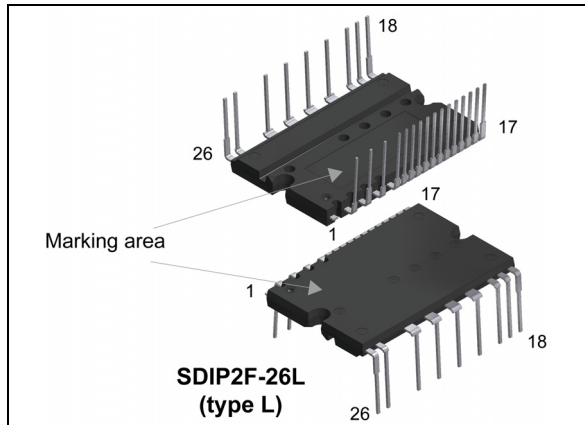

### Features

- IPM 8 A 600 V 3-phase IGBT inverter bridge including 2 control ICs for gate driving and freewheeling diodes
- 3.3 V, 5 V TTL/CMOS inputs with hysteresis
- Internal bootstrap diode
- Undervoltage lockout
- Smart shutdown function
- Short-circuit protection
- Shutdown input/fault output
- Separate open emitter outputs
- Built-in temperature sensor
- Comparator for fault protection
- Short-circuit rugged TFS IGBTs
- Very fast, soft recovery diodes
- 85 kΩ NTC UL 1434 CA 4 recognized
- Fully isolated package
- Isolation rating of 1500 Vrms/min

### Applications

- 3-phase inverters for motor drives
- Home appliances such as washing machines, refrigerators, air conditioners and sewing machine

### Description

This second series of SLLIMM (small low-loss intelligent molded module) provides a compact, high performance AC motor drive in a simple, rugged design. It combines new ST proprietary control ICs (one LS and one HS driver) with an improved short-circuit rugged trench gate field-stop (TFS) IGBT, making it ideal for 3-phase inverter systems such as home appliances and air conditioners. SLLIMM™ is a trademark of STMicroelectronics.

Table 1. Device summary

Order code	Marking	Package	Packaging
STGIF5CH60TS-L	GIF5CH60TS-L	SDIP2F-26L	Tube

# Contents

<b>1</b>	<b>Internal schematic and pin description</b> .....	<b>3</b>
<b>2</b>	<b>Absolute maximum ratings</b> .....	<b>5</b>
<b>3</b>	<b>Electrical characteristics</b> .....	<b>7</b>
<b>4</b>	<b>Fault management</b> .....	<b>11</b>
	4.1 TSO output .....	12
	4.2 Smart shutdown function .....	12
<b>5</b>	<b>Typical application circuit</b> .....	<b>15</b>
<b>6</b>	<b>Recommendations</b> .....	<b>16</b>
<b>7</b>	<b>NTC thermistor</b> .....	<b>18</b>
<b>8</b>	<b>Electrical characteristics (curves)</b> .....	<b>20</b>
<b>9</b>	<b>Package mechanical data</b> .....	<b>22</b>
<b>10</b>	<b>Revision history</b> .....	<b>24</b>

# 1 Internal schematic and pin description

Figure 1. Internal schematic diagram and pin configuration

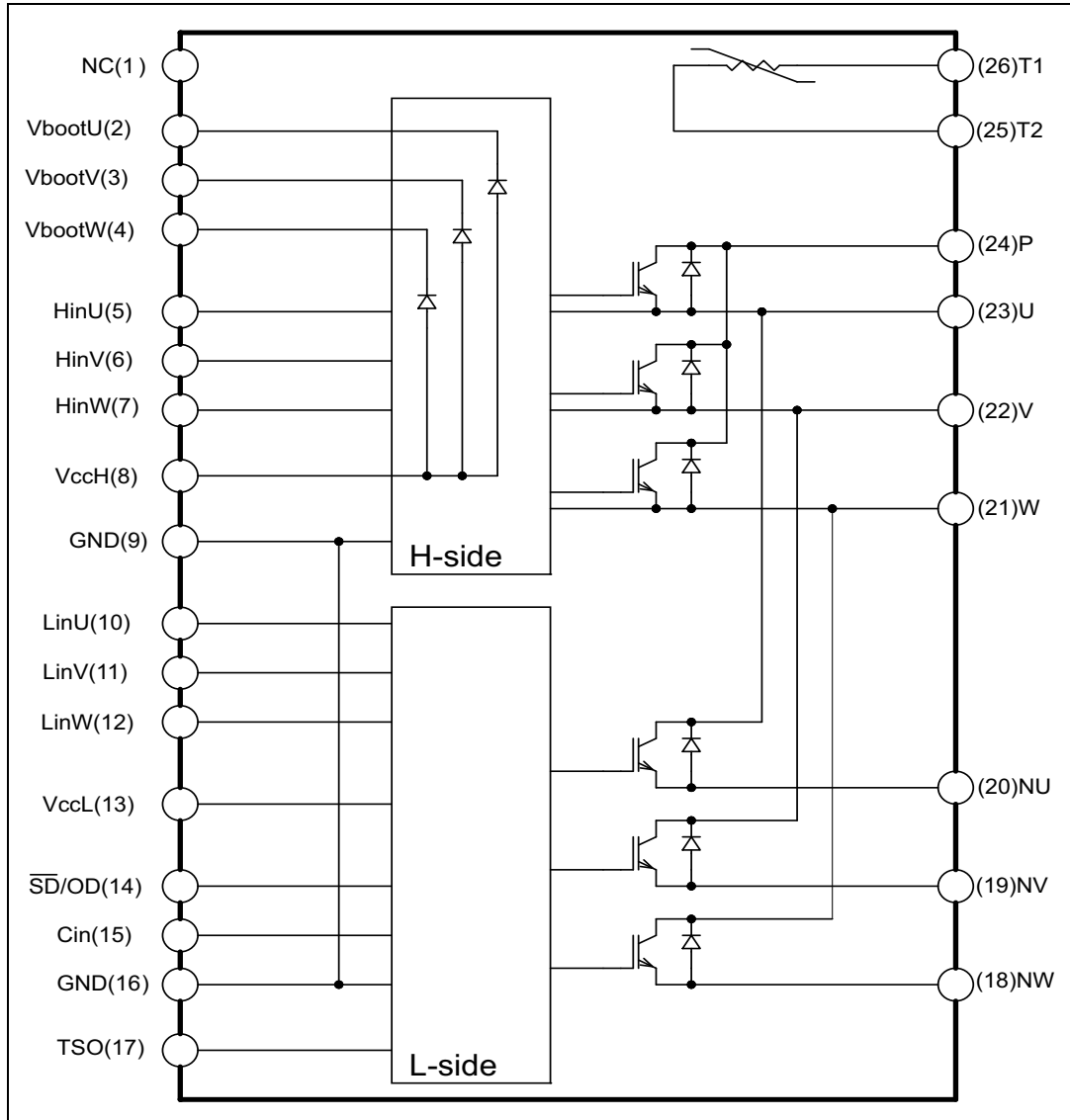

Table 2. Pin description

Pin	Symbol	Description
1	NC	-
2	VBOOTu	Bootstrap voltage for U phase
3	VBOOTv	Bootstrap voltage for V phase
4	VBOOTw	Bootstrap voltage for W phase
5	HINu	High-side logic input for U phase
6	HINv	High-side logic input for V phase
7	HINw	High-side logic input for W phase
8	VCCH	High-side low voltage power supply
9	GND	Ground
10	LINu	Low-side logic input for U phase
11	LINv	Low-side logic input for V phase
12	LINw	Low-side logic input for W phase
13	VCCL	Low-side low voltage power supply
14	$\overline{\text{SD/OD}}$	Shutdown logic input (active low) / open-drain (comparator output)
15	CIN	Comparator input
16	GND	Ground
17	TSO	Temperature sensor output
18	NW	Negative DC input for W phase
19	NV	Negative DC input for V phase
20	NU	Negative DC input for U phase
21	W	W phase output
22	V	V phase output
23	U	U phase output
24	P	Positive DC input
25	T2	NTC thermistor terminal 2
26	T1	NTC thermistor terminal 1

## 2 Absolute maximum ratings

( $T_J = 25^\circ\text{C}$  unless otherwise noted).

**Table 3. Inverter parts**

Symbol	Parameter	Value	Unit
$V_{PN}$	Supply voltage between P - $N_U$ , - $N_V$ , - $N_W$	450	V
$V_{PN(\text{surge})}$	Supply voltage surge between P - $N_U$ , - $N_V$ , - $N_W$	500	V
$V_{CES}$	Collector-emitter voltage each IGBT	600	V
$\pm I_C$	Continuous collector current each IGBT ( $T_C = 25^\circ\text{C}$ )	8	A
	Continuous collector current each IGBT ( $T_C = 80^\circ\text{C}$ )	5	
$\pm I_{CP}$	Peak collector current each IGBT (less than 1ms)	16	A
$P_{TOT}$	Total dissipation at $T_C = 25^\circ\text{C}$ each IGBT	30	W
$t_{SCW}$	Short-circuit withstand time, $V_{CE} = 300\text{ V}$ , $T_J = 125^\circ\text{C}$ , $V_{CC} = V_{boot} = 15\text{ V}$ , $V_{IN} = 0$ to $5\text{ V}$	5	$\mu\text{s}$

**Table 4. Control parts**

Symbol	Parameter	Min	Max	Unit
$V_{CC}$	Supply voltage between $V_{CCH}$ -GND, $V_{CCL}$ -GND	-0.3	20	V
$V_{BOOT}$	Bootstrap voltage	-0.3	619	V
$V_{OUT}$	Output voltage between U, V, W and GND	$V_{BOOT} - 21$	$V_{BOOT} + 0.3$	V
$V_{CIN}$	Comparator input voltage	-0.3	20	V
$V_{IN}$	Logic input voltage applied between $HINx$ , $LINx$ and GND	-0.3	15	V
$V_{\overline{SD}/OD}$	Open drain voltage	-0.3	7	V
$I_{\overline{SD}/OD}$	Open drain sink current	-	10	mA
$V_{TSO}$	Temperature sensor output voltage	-0.3	5.5	V
$I_{TSO}$	Temperature sensor output current	-	7	A

**Table 5. Total system**

Symbol	Parameter	Value	Unit
$V_{ISO}$	Isolation withstand voltage applied between each pin and heat sink plate (AC voltage, $t = 60\text{sec.}$ )	1500	Vrms
$T_J$	Power chips operating junction temperature	-40 to 175	$^\circ\text{C}$
$T_C$	Module case operation temperature	-40 to 125	$^\circ\text{C}$

Table 6. Thermal data

Symbol	Parameter	Value	Unit
$R_{th(j-c)}$	Thermal resistance junction-case single IGBT	5	°C/W
	Thermal resistance junction-case single diode	9	

### 3 Electrical characteristics

(T<sub>j</sub>= 25°C unless otherwise noted)

**Table 7. Inverter parts**

Symbol	Parameter	Test condition	Min	Typ	Max	Unit
I <sub>CES</sub>	Collector-cut off current	V <sub>CE</sub> = 600 V, V <sub>CC</sub> = V <sub>boot</sub> = 15 V	-		100	μA
V <sub>CE(sat)</sub>	Collector-emitter saturation voltage	V <sub>CC</sub> = V <sub>Boot</sub> = 15 V, V <sub>IN</sub> <sup>(1)</sup> = 0 to 5 V, I <sub>C</sub> = 5 A,	-	1.5	1.95	V
		V <sub>CC</sub> = V <sub>Boot</sub> = 15 V, V <sub>IN</sub> <sup>(1)</sup> = 0 to 5 V, I <sub>C</sub> = 8 A,	-	1.7		
V <sub>F</sub>	Diode forward voltage	V <sub>IN</sub> <sup>(1)</sup> = 0, I <sub>C</sub> = 5 A	-	2.1	2.7	V
		V <sub>IN</sub> <sup>(1)</sup> = 0, I <sub>C</sub> = 8 A	-	2.4		V
<b>Inductive load switching time and energy <sup>(2)</sup></b>						
t <sub>on</sub>	Turn-on time	V <sub>DD</sub> = 300 V, V <sub>CC</sub> = V <sub>boot</sub> = 15 V, V <sub>IN</sub> <sup>(1)</sup> = 0 to 5 V, I <sub>C</sub> = 5 A	-	265		ns
t <sub>c(on)</sub>	Cross-over time on		-	110		
t <sub>off</sub>	Turn-off time		-	305		
t <sub>c(off)</sub>	Cross-over time off		-	92		
t <sub>rr</sub>	Reverse recovery time		-	100		
E <sub>on</sub>	Turn-on switching loss	V <sub>DD</sub> = 300 V, V <sub>CC</sub> = V <sub>boot</sub> = 15 V, V <sub>IN</sub> <sup>(1)</sup> = 0 to 5 V, I <sub>C</sub> = 5 A	-	90		μJ
E <sub>off</sub>	Turn-off switching loss		-	60		
E <sub>rr</sub>	Reverse recovery energy loss			5.6		
t <sub>on</sub>	Turn-on time	V <sub>DD</sub> = 300 V, V <sub>CC</sub> = V <sub>boot</sub> = 15 V, V <sub>IN</sub> <sup>(1)</sup> = 0 to 5 V, I <sub>C</sub> = 8 A	-	282		ns
t <sub>c(on)</sub>	Cross-over time on		-	126		
t <sub>off</sub>	Turn-off time		-	295		
t <sub>c(off)</sub>	Cross-over time off		-	90		
t <sub>rr</sub>	Reverse recovery time		-	100		
E <sub>on</sub>	Turn-on switching loss	V <sub>DD</sub> = 300 V, V <sub>CC</sub> = V <sub>boot</sub> = 15 V, V <sub>IN</sub> <sup>(1)</sup> = 0 to 5 V, I <sub>C</sub> = 8 A	-	163		μJ
E <sub>off</sub>	Turn-off switching loss		-	86		
E <sub>rr</sub>	Reverse recovery energy loss			9.2		

1. Applied between HIN<sub>x</sub>, LIN<sub>x</sub> and GND for x = U, V, W
2. t<sub>on</sub> and t<sub>off</sub> include the propagation delay time of the internal drive. t<sub>c(on)</sub> and t<sub>c(off)</sub> are the switching time of IGBT itself under the internally given gate driving condition.

Figure 2. Switching time test circuit

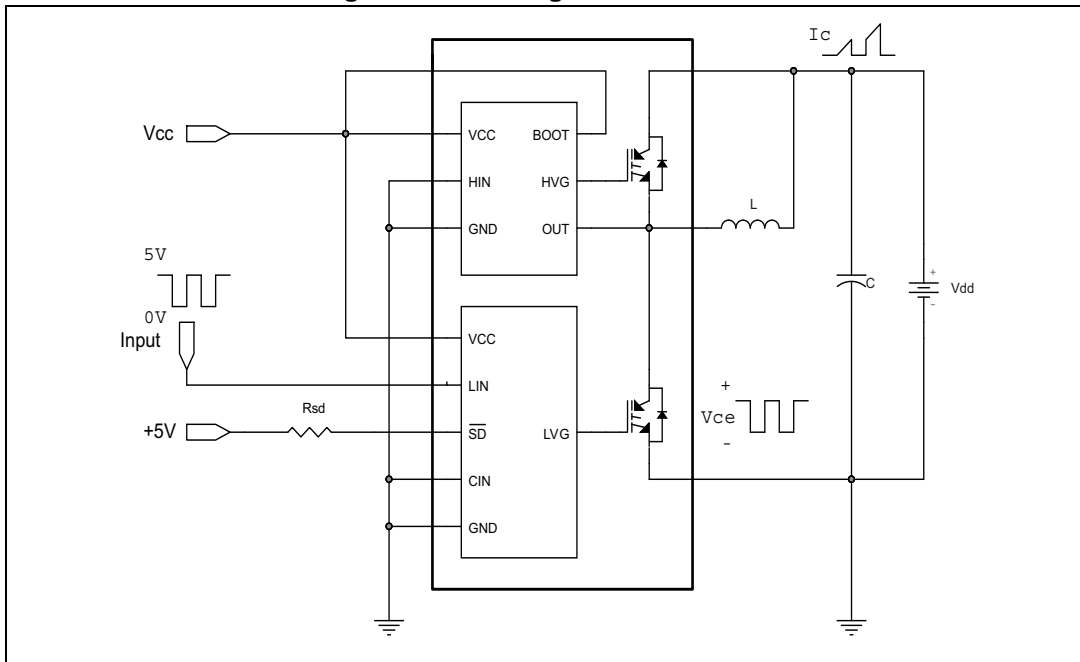

Figure 3. Switching time definition

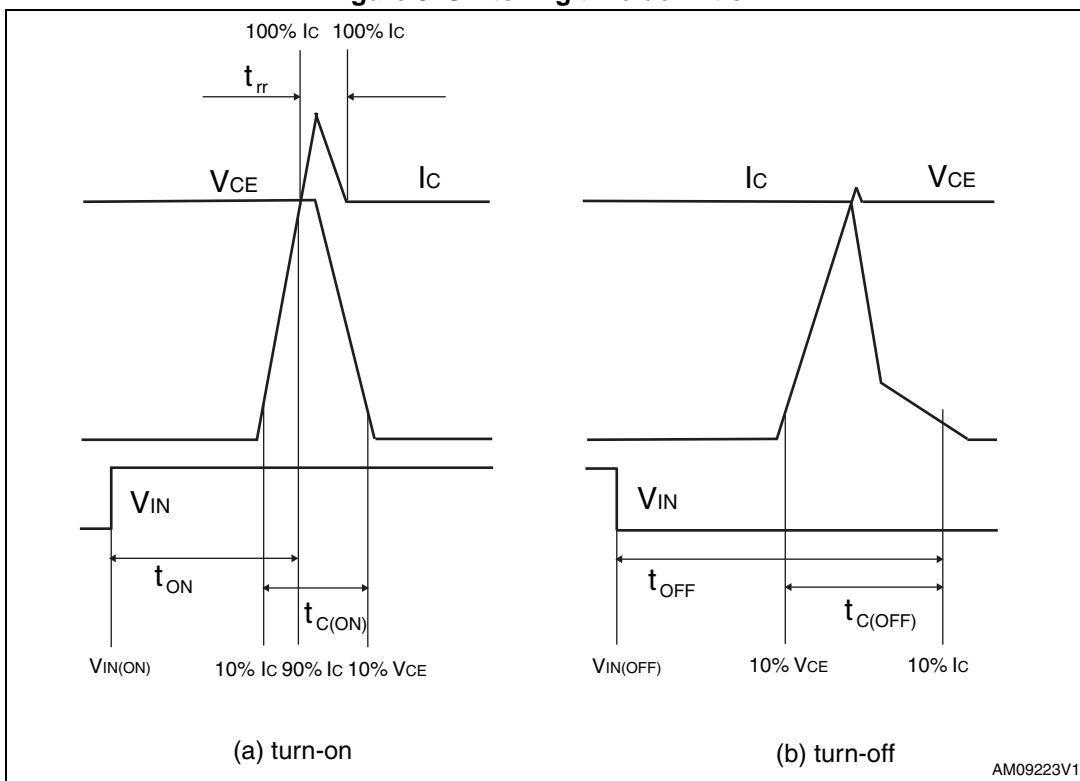



Table 8. Control / protection parts

Symbol	Parameter	Test condition	Min	Typ	Max	Unit
$V_{il}$	Low logic level voltage				0.8	V
$V_{ih}$	High logic level voltage		2			V
$I_{INh}$	IN logic "1" input bias current	$IN_x=15V$	80	150	200	$\mu A$
$I_{INl}$	IN logic "0" input bias current	$IN_x=0V$			1	$\mu A$
<b>High side</b>						
$V_{CC\_hys}$	$V_{CC}$ UV hysteresis		1.2	1.4	1.7	V
$V_{CCH\_th(on)}$	$V_{CCH}$ UV turn-on threshold		11	11.5	12	V
$V_{CCH\_th(off)}$	$V_{CCH}$ UV turn-off threshold		9.6	10.1	10.6	V
$V_{BS\_hys}$	$V_{BS}$ UV hysteresis		0.5	1	1.6	V
$V_{BS\_th(on)}$	$V_{BS}$ UV turn-on threshold		10.1	11	11.9	V
$V_{BS\_th(off)}$	$V_{BS}$ UV turn-off threshold		9.1	10	10.9	V
$I_{QBSU}$	Under voltage $V_{BS}$ quiescent current	$V_{BS} = 9 V, HINx^{(1)} = 5V;$		55	75	$\mu A$
$I_{QBS}$	$V_{BS}$ quiescent current	$V_{CC} = 15 V,$ $HINx^{(1)} = 5V$		125	170	$\mu A$
$I_{qccu}$	Under voltage quiescent supply current	$V_{CC} = 9 V, HINx^{(1)} = 0$		190	250	$\mu A$
$I_{qcc}$	Quiescent current	$V_{CC} = 15 V, HINx^{(1)} = 0$		560	730	$\mu A$
$R_{DS(on)}$	BS driver ON resistance			150		$\Omega$
<b>Low side</b>						
$V_{CC\_hys}$	$V_{CC}$ UV hysteresis		1.1	1.4	1.6	V
$V_{CCL\_th(on)}$	$V_{CCL}$ UV turn-on threshold		10.4	11.6	12.4	V
$V_{CCL\_th(off)}$	$V_{CCL}$ UV turn-off threshold		9.0	10.3	11	V
$I_{qccu}$	Under voltage quiescent supply current	$V_{CC} = 10 V, \overline{SD}$ pulled to 5V through $R_{SD} = 10k\Omega,$ $CIN = LINx^{(1)} = 0;$		600	800	$\mu A$
$I_{qcc}$	Quiescent current	$V_{CC} = 15 V, \overline{SD} = 5V,$ $CIN = LINx^{(1)} = 0;$		700	900	$\mu A$
$V_{SSD}$	Smart $\overline{SD}$ unlatch threshold		0.5	0.6	0.75	V
$I_{SDh}$	$\overline{SD}$ logic "1" input bias current	$\overline{SD} = 5V$	25	50	70	$\mu A$
$I_{SDl}$	$\overline{SD}$ logic "0" input bias current	$\overline{SD} = 0V$			1	$\mu A$

**Table 8. Control / protection parts (continued)**

Symbol	Parameter	Test condition	Min	Typ	Max	Unit
<b>Temperature sensor output</b>						
$V_{TSO}$	Temperature sensor output voltage	$T_j = 25\text{ }^\circ\text{C}$		1.4		V
$I_{TSO\_SNK}$	Temperature sensor sink current capability			0.1		mA
$I_{TSO\_SRC}$	Temperature sensor source current capability		4			mA

1. Applied between HINx, LINx and GND for x = U, V, W

**Table 9. Sense comparator ( $V_{CC} = 15\text{ V}$ , unless otherwise is specified)**

Symbol	Parameter	Test condition	Min	Typ	Max	Unit
$I_{CIN}$	CIN input bias current	$V_{CIN} = 1\text{V}$	-0.2		0.2	$\mu\text{A}$
$V_{ref}$	Internal reference voltage		460	510	560	mV
$V_{OD}$	Open drain low level output voltage	$I_{od} = 5\text{mA}$			500	mV
$t_{CIN\_SD}$	$C_{IN}$ comparator delay to $\overline{SD}$	$\overline{SD}$ pulled to 5V through $R_{SD}=10\text{k}\Omega$ ; measured applying a voltage step 0-1V to Pin CIN 50% CIN to 90% $\overline{SD}$	150	230	320	ns
$SR_{SD}$	$\overline{SD}$ fall slew rate	$\overline{SD}$ pulled to 5V through $R_{SD}=10\text{k}\Omega$ ; $C_L=1\text{nF}$ through $\overline{SD}$ and ground; 90% $\overline{SD}$ to 10% $\overline{SD}$		25		$\text{V}/\mu\text{s}$

*Note:* Comparator stay enabled even if  $V_{CC}$  is in UVLO condition but higher than 4 V.

## 4 Fault management

The device integrates an open-drain output connected to  $\overline{SD}$  Pin. As soon as a fault occurs the open-drain is activated and LVGx outputs are forced low. Two types of fault can be pointed out:

- Overcurrent (OC) sensed by the internal comparator (see more detail in [Section 4.2: Smart shutdown function](#));
- Undervoltage on supply voltage ( $V_{CC}$ );

Each fault enables the SD open drain for a different time; refer to the following [Table 10: Fault timing](#).

**Table 10. Fault timing**

Symbol	Parameter	Event time	SD open-drain enable time result
OC	Over-current event	$\leq 20 \mu s$	20 $\mu s$
		$\geq 20 \mu s$	OC time
UVLO	Under-voltage lock out event	$\leq 50 \mu s$	50 $\mu s$
		$\geq 50 \mu s$ until the $V_{CC\_LS}$ exceed the $V_{CC\_LS}$ UV turn ON threshold	UVLO time

Actually the device remains in a fault condition ( $\overline{SD}$  at low logic level and LVGx outputs disabled) for a time also depending on RC network connected to  $\overline{SD}$  pin. The network generates a time contribution that adds up to the internal value.

**Figure 4. Overcurrent timing (without contribution of RC network on  $\overline{SD}$ )**

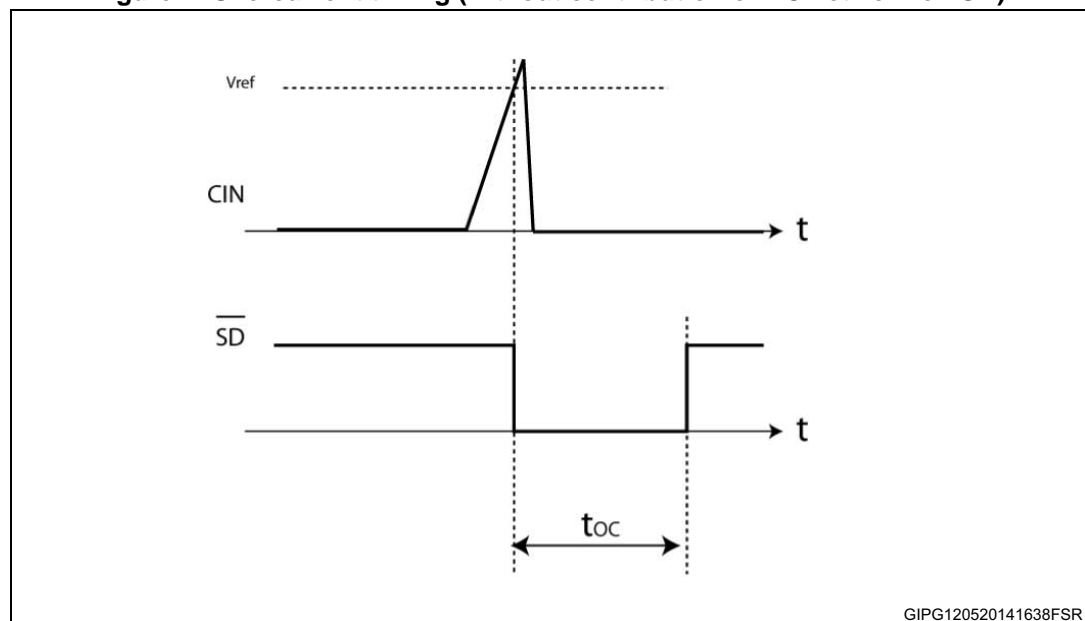

GIPG120520141638FSR

Figure 5. UVLO timing (without contribution of RC network on  $\overline{SD}$ )

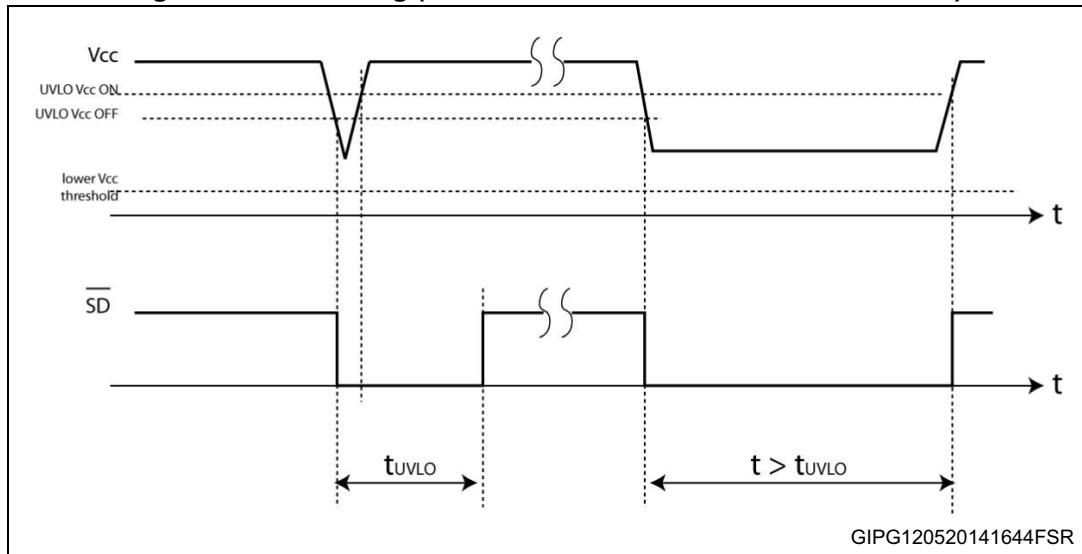

GIPG120520141644FSR

### 4.1 TSO output

The device integrates temperature sensor. A voltage proportional to die temperature is available on TSO pin. When this function is not used the Pin can be left floating.

### 4.2 Smart shutdown function

The device integrates a comparator committed to the fault sensing function. The comparator input can be connected to an external shunt resistor in order to implement a simple overcurrent detection function.

The output signal of the comparator is fed to an integrated MOSFET with the open drain output available on  $\overline{SD}$  input. When the comparator triggers, the device is set in shutdown state and its outputs are all set to low level.

Figure 6. Smart shutdown timing waveforms in case of overcurrent event

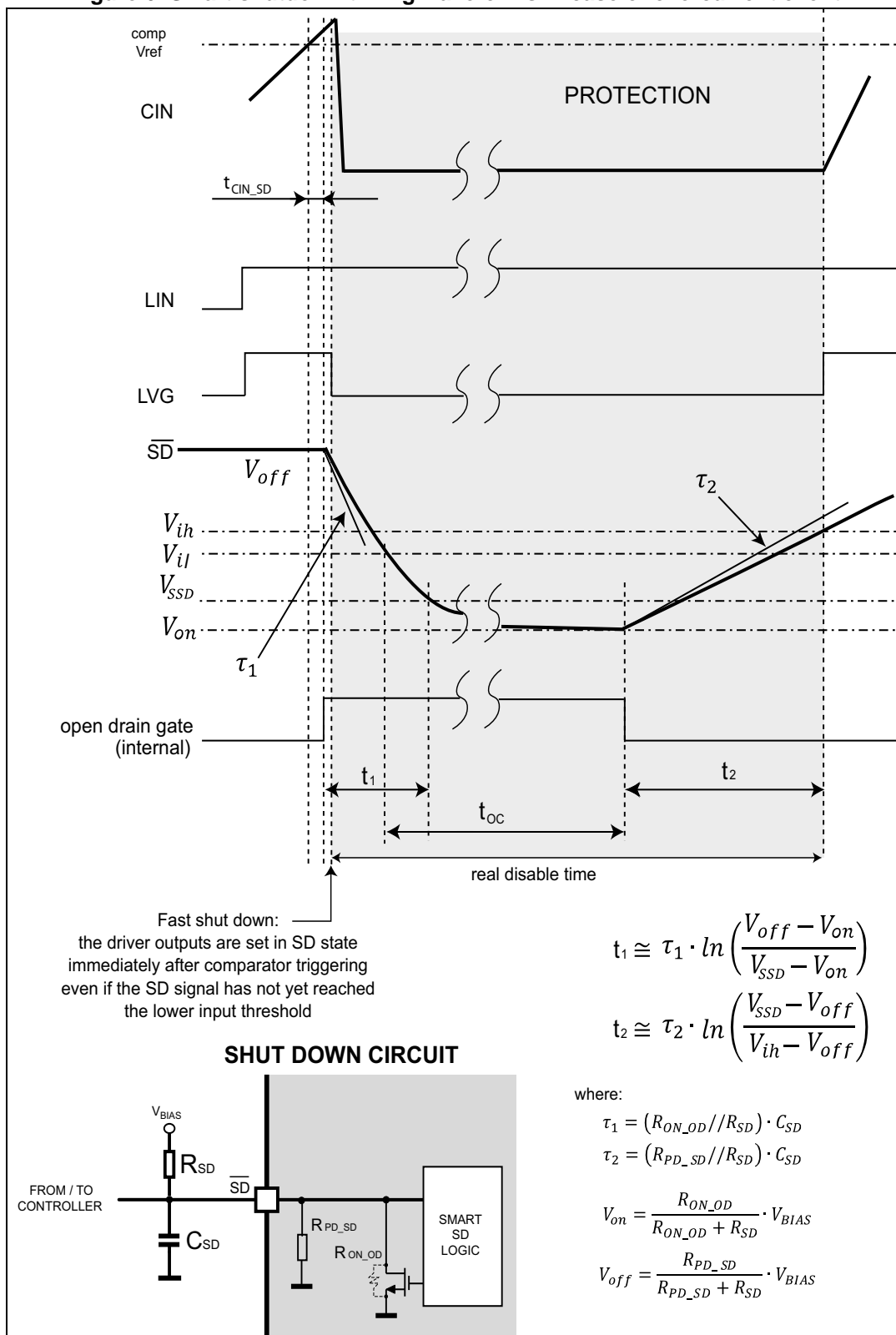

Note:  $R_{ON\_OD} = V_{OD} / 5 \text{ mA}$  see Table 9;  $R_{PD\_SD} (typ) = 5 \text{ V} / I_{SDh}$

In common over-current protection architectures the comparator output is usually connected to the  $\overline{SD}$  input and an RC network is connected to this  $\overline{SD}$  line in order to provide a mono-stable circuit, which implements a protection time that follows the fault condition.

Differently from the common fault detection systems, the device Smart shutdown architecture allows to immediately turn-off the outputs gate driver in case of fault, by minimizing the propagation delay between the fault detection event and the actual outputs switch-off. In fact the time delay between the fault and the outputs turn off is no more dependent on the RC value of the external network connected to the pin.

In the smart shutdown circuitry, the fault signal has a preferential path which directly switches off the outputs after the comparator triggering.

At the same time the internal logic turns on the open drain output and holds it on until the  $\overline{SD}$  voltage goes below the  $V_{SSD}$  threshold and  $t_{oc}$  time is elapsed.

The driver outputs restart following the input pins as soon as the voltage at the  $\overline{SD}$  pin reaches the higher threshold of the  $\overline{SD}$  logic input.

The Smart shutdown system provides the possibility to increase the time constant of the external RC network (that is the disable time after the fault event) up to very large values without increasing the delay time of the protection.

# 5 Typical application circuit

Figure 7. Typical application circuit

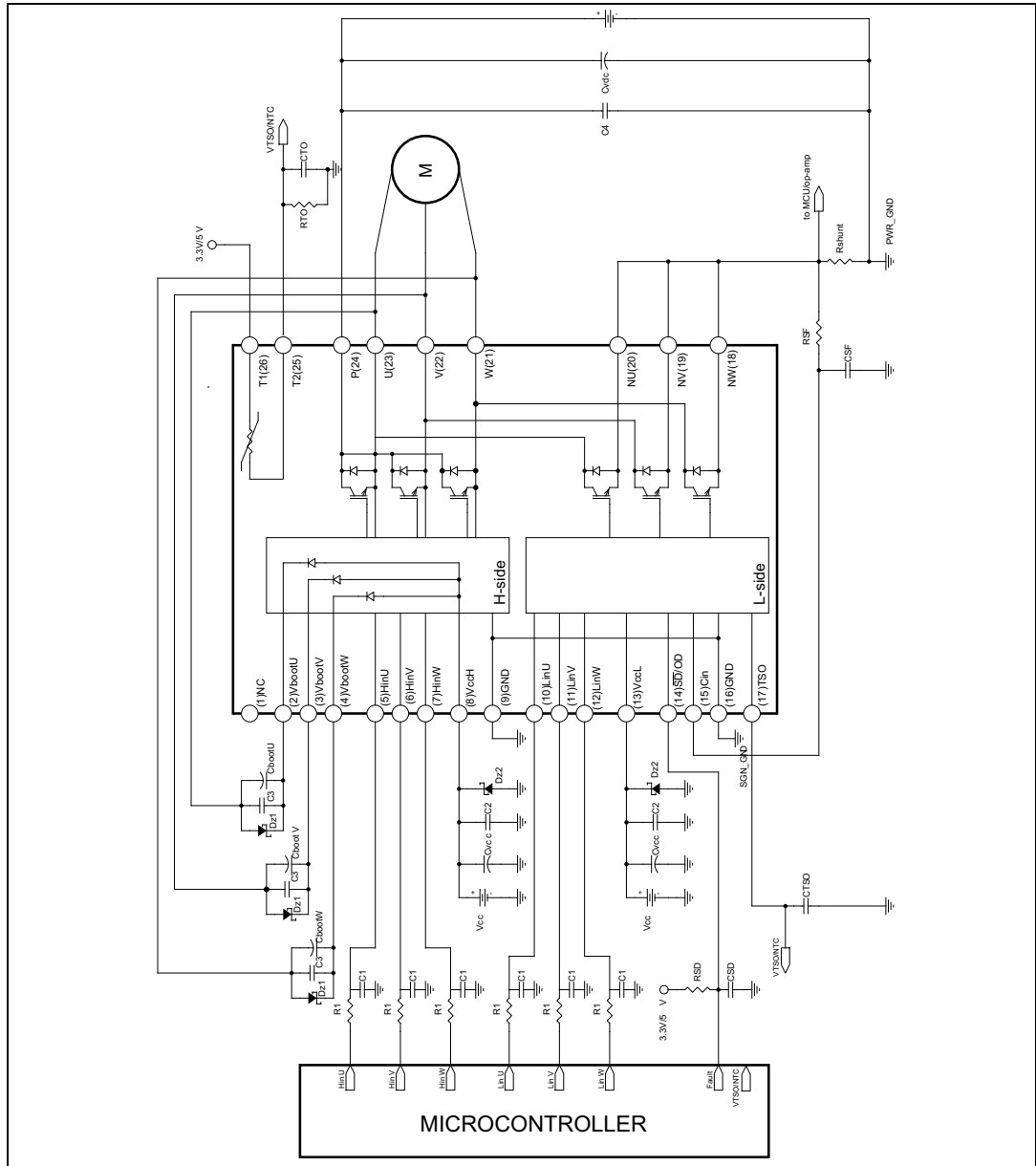

## 6 Recommendations

1. Input signals HIN, LIN are active-high logic. A 500 k $\Omega$  (typ.) pull-down resistor is built-in for each high side input. To prevent input signal oscillation, the wiring of each input should be as short as possible and the use of RC filters (R1, C1) on each input signal is suggested. The filters should be done with a time constant of about 100 ns and must be placed as close as possible to the IPM input pins.
2. The bypass capacitor C<sub>vcc</sub> (aluminum or tantalum) is recommended to reduce the transient circuit demand on the power supply. In addition, a decoupling capacitor C<sub>2</sub> (100 to 220 nF, with low ESR and low ESL) is suggested, to reduce high frequency switching noise distributed on the power supply lines. It must be placed as close as possible to each V<sub>cc</sub> pin and in parallel to the bypass capacitor.
3. The use of RC filter (RSF, CSF) for preventing protection circuit malfunction is recommended. The time constant (RSF x CSF) should be set to 1us and the filter must be placed as close as possible to the CIN pin.
4. The  $\overline{SD}$  is an input/output pin (open drain type if used as output). It should be pulled up to MCU power supply (3.3/5 V) by a resistor higher than 1.0 k $\Omega$  in order to keep I<sub>od</sub> lower than 5 mA. The filter on SD has to be sized to get a desired re-starting time after a fault event and placed as close as possible to the  $\overline{SD}$  pin.
5. To increase the noise immunity of the TSO thermal sensor, it is recommended to parallel a decoupling capacitor C<sub>T<sub>TSO</sub></sub> between 1nF and 10nF. Similarly, if the NTC thermistor is available and used, it is recommended to parallel a decoupling capacitor C<sub>O<sub>T</sub></sub> between 10nF and 100nF. In both cases, the capacitors must be placed close to the MCU.
6. The decoupling capacitor C<sub>3</sub> (100 to 220 nF, with low ESR and low ESL) in parallel with each C<sub>boot</sub> is recommended to filter high frequency disturbances. Both C<sub>boot</sub> and C<sub>3</sub> must be placed as close as possible to the U,V,W and V<sub>boot</sub> pins. Bootstrap negative electrodes should be connected to U,V,W terminals directly and separated from the main output wires.
7. A Zener diode (Dz1) between each V<sub>cc</sub> pin and GND, and in parallel (Dz2) with each Cboot is suggested in order to prevent overvoltage.
8. The decoupling capacitor C<sub>4</sub> (100 to 220 nF, with low ESR and low ESL) in parallel with the electrolytic capacitor C<sub>vdc</sub> is recommended, in order to prevent surge destruction. Both capacitors C<sub>4</sub> and C<sub>vdc</sub> should be placed as close as possible to the IPM (C<sub>4</sub> has priority over C<sub>vdc</sub>).
9. By integrating an application-specific type HVIC inside the module, direct coupling to the MCU terminals without an opto-coupler is possible.
10. Low inductance shunt resistors should be used for phase leg current sensing
11. In order to avoid malfunctions, the wiring between N pins, the shunt resistor and PWR\_GND should be as short as possible.
12. It is recommended to connect SGN\_GND to PWR\_GND at only one point (near the terminal of shunt resistor), in order to avoid any malfunction due to power ground fluctuation.



Table 11. Recommended operating conditions

Symbol	Parameter	Test condition	Min	Typ	Max	Unit
$V_{PN}$	Supply voltage	Applied between P-Nu, N <sub>V</sub> , N <sub>W</sub>		300	400	V
$V_{CC}$	Control supply voltage	Applied between V <sub>CC</sub> -GND	13.5	15	18	V
$V_{BS}$	High side bias voltage	Applied between V <sub>BOOTi</sub> -OUT <sub>i</sub> for i = U, V, W	13		18	V
$t_{dead}$	Blanking time to prevent Arm-short	For each input signal	1.0			μs
$f_{PWM}$	PWM input signal	-40 °C < T <sub>C</sub> < 100 °C -40 °C < T <sub>j</sub> < 125 °C			20	kHz
T <sub>C</sub>	Case operation temperature				100	°C

# 7 NTC thermistor

Table 12. NTC thermistor

Symbol	Parameter	Test condition	Min	Typ	Max	Unit
R <sub>25</sub>	Resistance	T = 25°C		85	-	kΩ
R <sub>125</sub>	Resistance	T = 125°C		2.6	-	kΩ
B	B-constant	T = 25°C to 100°C		4092	-	K
T	Operating temperature range		-40		125	°C

Figure 8. NTC resistance vs. temperature

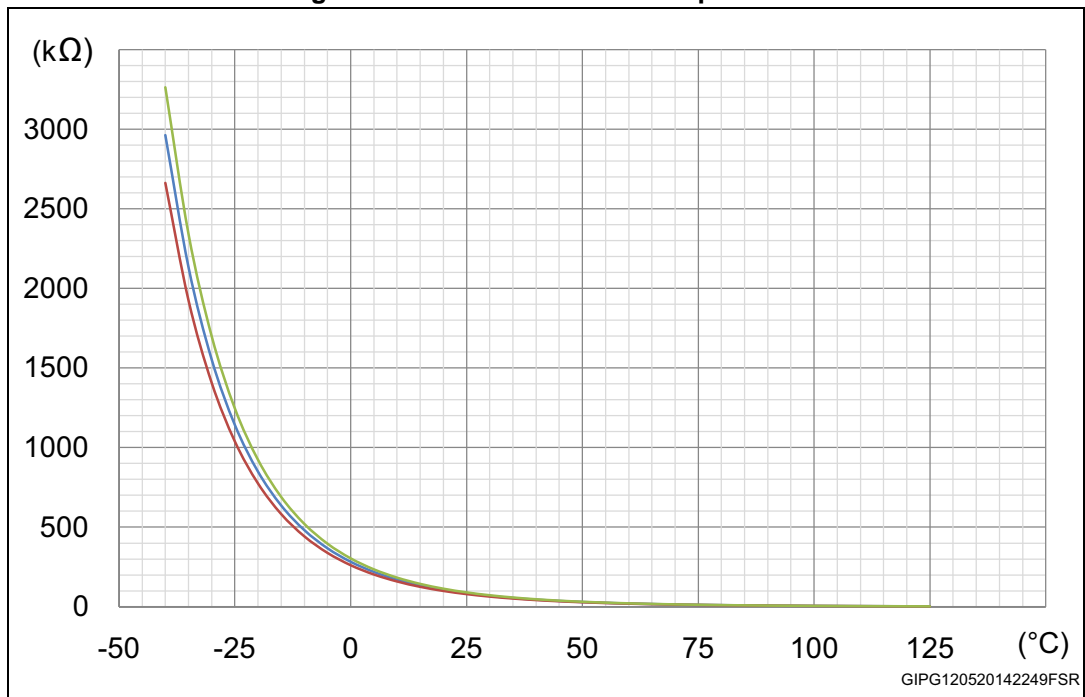
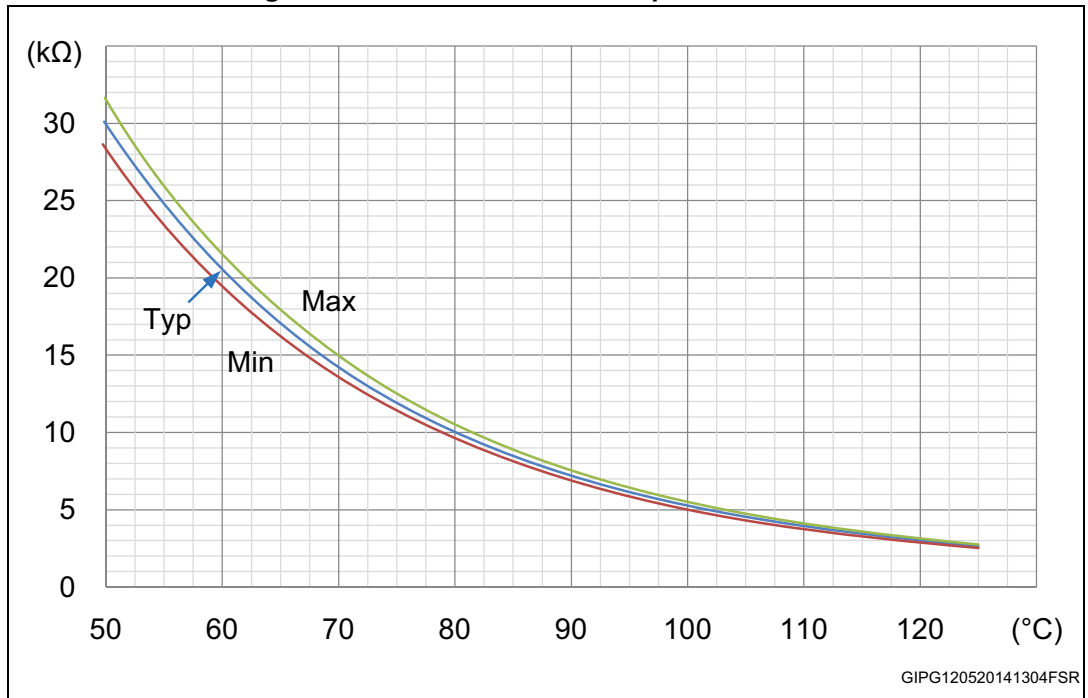

Figure 9. NTC resistance vs. temperature - zoom



# 8 Electrical characteristics (curves)

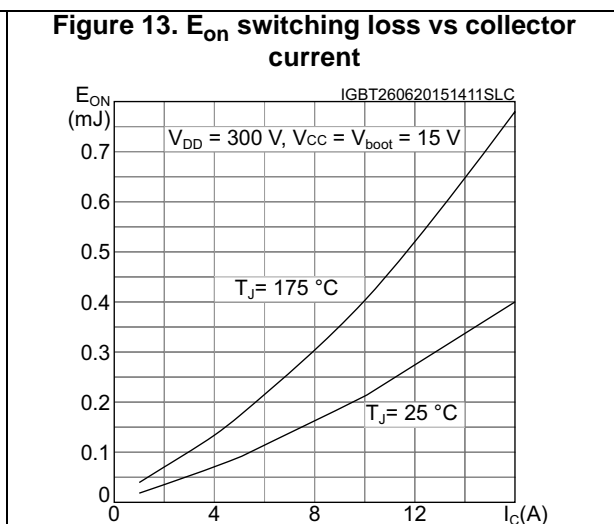
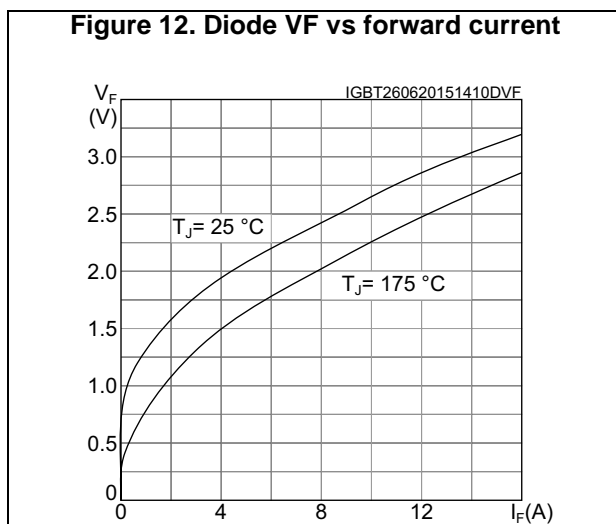
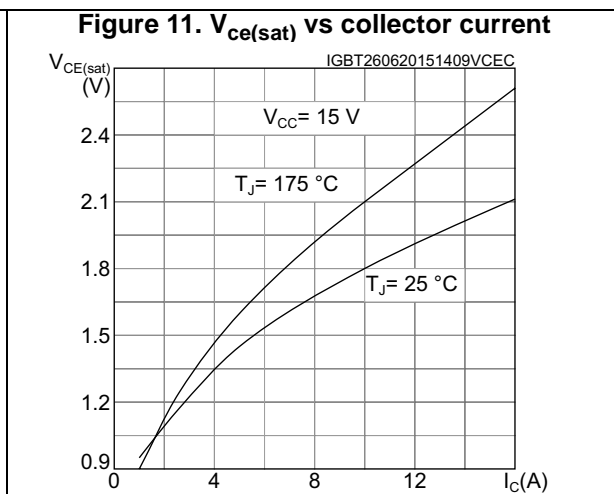
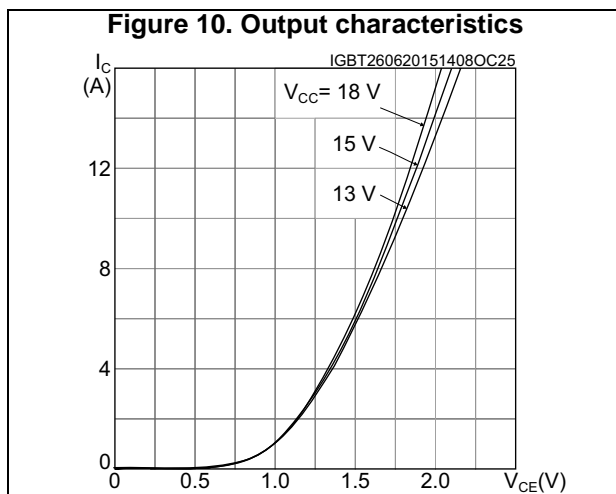

Figure 14.  $E_{off}$  switching loss vs collector current

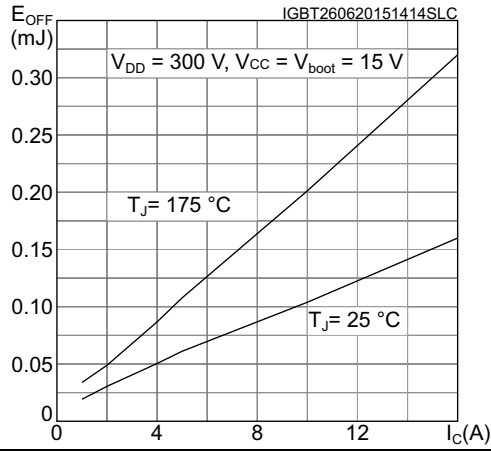

Figure 15. VT<sub>SO</sub> output characteristics vs LVIC temperature

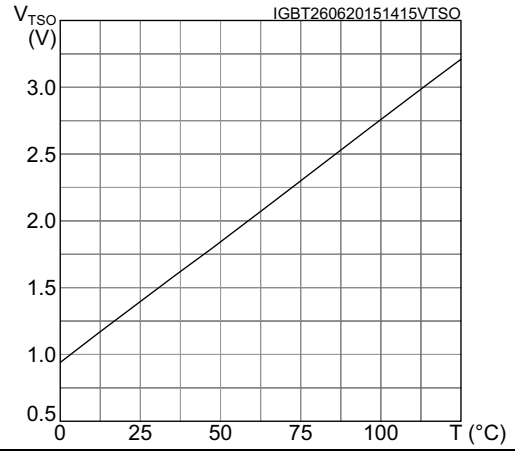
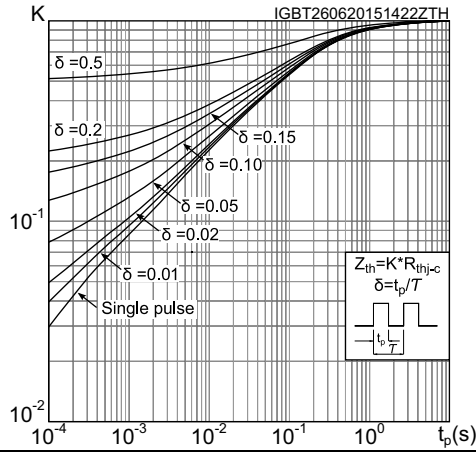

Figure 16. Thermal impedance for SDIP2F-26L IGBT



## 9 Package mechanical data

In order to meet environmental requirements, ST offers these devices in different grades of ECOPACK<sup>®</sup> packages, depending on their level of environmental compliance. ECOPACK<sup>®</sup> specifications, grade definitions and product status are available at: [www.st.com](http://www.st.com). ECOPACK<sup>®</sup> is an ST trademark.

Figure 17. SDIP2F-26L type L mechanical drawing

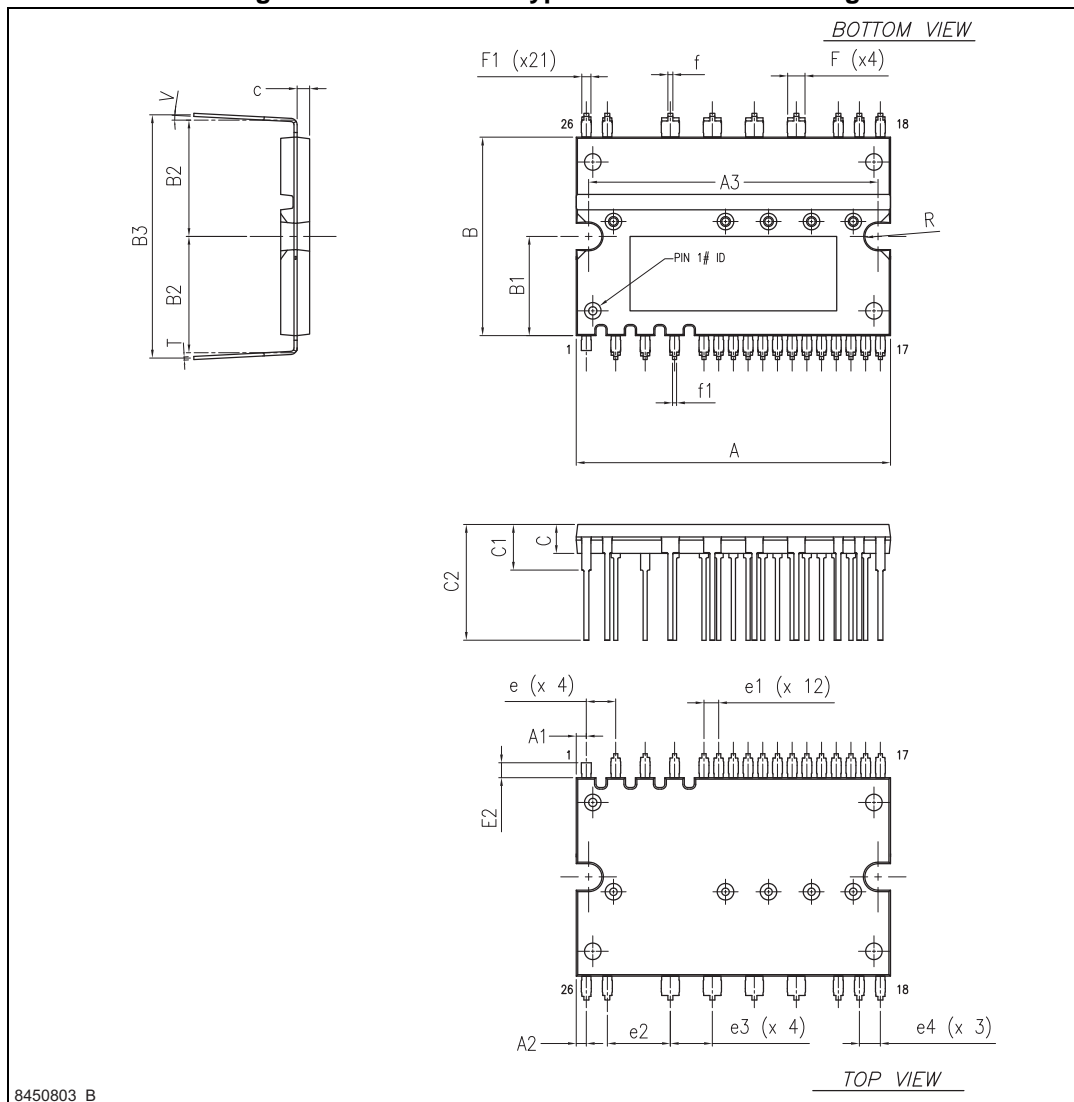

Table 13. SDIP2F-26L type L mechanical dimensions<sup>(1)</sup>

Ref.	Dimensions	Ref.	Dimensions	Ref.	Dimensions
A	38.00 ± 0.50	B3	29.40 ± 0.50	e4	2.54 ± 0.20
A1	1.22 ± 0.25	C	3.50 ± 0.20	f	0.60 ± 0.15
A2	1.22 ± 0.25	C1	5.50 ± 0.50	f1	0.50 ± 0.15
A3	35.00 ± 0.30	C2	14.00 ± 0.50	F	2.10 ± 0.15
c	1.50 ± 0.05	e	3.556 ± 0.200	F1	1.10 ± 0.15
B	24.00 ± 0.50	e1	1.778 ± 0.200	R	1.60 ± 0.20
B1	12.00	e2	7.62 ± 0.20	T	0.400 ± 0.025
B2	14.40 ± 0.50	e3	5.08 ± 0.20	V	0° / 5°

1. All dimensions are expressed in millimeters.

# 10 Revision history

**Table 14. Document revision history**

Date	Revision	Changes
20-Jun-2014	1	Initial release.
07-Aug-2014	2	Updated <i>Chapter 8: Package mechanical data</i> .
26-Jun-2015	3	Text and formatting changes throughout document On cover page: - updated Title, <i>Features</i> and <i>Description</i> In <i>Section 1: Internal schematic and pin description</i> : - updated <i>Figure 1</i> and <i>Table 2</i> In <i>Section 2: Absolute maximum ratings</i> : - updated <i>Table 3</i> , <i>Table 4</i> , <i>Table 5</i> and <i>Table 6</i> In <i>Section 3: Electrical characteristics</i> : - updated <i>Table 7</i> , <i>Figure 2</i> , <i>Table 8</i> and <i>Table 9</i> In <i>Section 4: Fault management</i> : - updated <i>Figure 6</i> In <i>Section 5: Typical application circuit</i> : - updated <i>Figure 7</i> In <i>Section 6: Recommendations</i> : - updated recommendations list and added <i>Table 11</i> In <i>Section 8: Electrical characteristics (curves)</i> : - added <i>Figure 10</i> , <i>Figure 11</i> , <i>Figure 12</i> , <i>Figure 13</i> , <i>Figure 14</i> , <i>Figure 15</i> and <i>Figure 16</i> Datasheet promoted from preliminary data to production data.
23-Jul-2015	4	Updated title in cover page and <i>Table 3</i> .
09-Sep-2015	5	Modified: description and features in cover page Minor text changes



**IMPORTANT NOTICE – PLEASE READ CAREFULLY**

STMicroelectronics NV and its subsidiaries ("ST") reserve the right to make changes, corrections, enhancements, modifications, and improvements to ST products and/or to this document at any time without notice. Purchasers should obtain the latest relevant information on ST products before placing orders. ST products are sold pursuant to ST's terms and conditions of sale in place at the time of order acknowledgement.

Purchasers are solely responsible for the choice, selection, and use of ST products and ST assumes no liability for application assistance or the design of Purchasers' products.

No license, express or implied, to any intellectual property right is granted by ST herein.

Resale of ST products with provisions different from the information set forth herein shall void any warranty granted by ST for such product.

ST and the ST logo are trademarks of ST. All other product or service names are the property of their respective owners.

Information in this document supersedes and replaces information previously supplied in any prior versions of this document.

© 2015 STMicroelectronics – All rights reserved

