

## Low voltage high bandwidth quad DPDT switch

Datasheet - production data

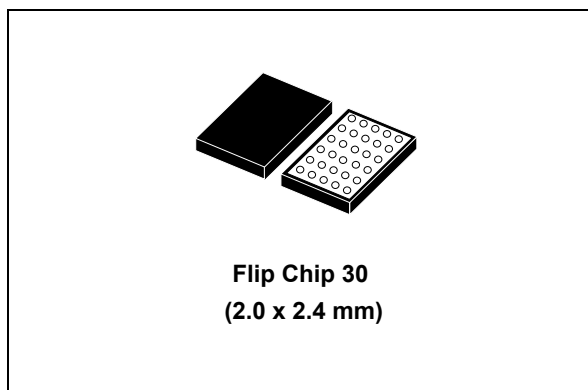

### Features

- Ultralow power dissipation
  - $I_{CC} = 1 \mu\text{A}$  (max.) at  $T_A = 85^\circ\text{C}$
- Low “ON” resistance
  - $R_{ON} = 5.4 \Omega$  ( $T_A = 25^\circ\text{C}$ ) at  $V_{CC} = 4.3 \text{ V}$
  - $R_{ON} = 6.6 \Omega$  ( $T_A = 25^\circ\text{C}$ ) at  $V_{CC} = 3.0 \text{ V}$
- Wide operating voltage range
  - $V_{CC}$  (OPR.) = 1.65 V to 4.3 V
- 4.3 V tolerant and 1.8 V compatible threshold on digital control input at  $V_{CC} = 2.3 \text{ V}$  to 3.0 V
- 4 select pins controlling 2 switches each
- Typical bandwidth (-3 dB) at 800 MHz on all channels
- USB (2.0) high speed (480 Mbps) signal switching compliant
- Integrated fail safe function
- Latch-up performance exceeds 100 mA per JESD 78, Class II
- ESD performance exceeds JESD22 2000-V human body model (A114-A)

### Applications

- Mobile phones

### Description

The STG3820 device is a high-speed CMOS low voltage quad analog DPDT (dual pole dual throw) switch or 2:1 multiplexer/demultiplexer switch fabricated in silicon gate C<sup>2</sup>MOS technology. It is designed to operate from 1.65 V to 4.3 V, making this device ideal for portable applications.

The SEL<sub>m-n</sub> input is provided to control the switches. The switches nS1 and mS1 are ON (connected to common ports D<sub>n</sub> and D<sub>m</sub> respectively) when the SEL<sub>m-n</sub> input is held high and OFF (high impedance state exists between the two ports) when the SEL<sub>m-n</sub> is held low. The switches nS2 and mS2 are ON (connected to common port D<sub>n</sub> and D<sub>m</sub> respectively) when the SEL<sub>m-n</sub> input is held low and OFF (high impedance state exists between the two ports) when the SEL<sub>m-n</sub> is held high.

The STG3820 device has an integrated fail safe function to withstand overvoltage condition when the device is powered off. Additional key features are fast switching speed, break-before-make-delay time and ultralow power consumption. All inputs and outputs are equipped with protection circuits against static discharge, giving them ESD immunity and transient excess voltage.

**Table 1. Device summary**

Order code	Package	Packing
STG3820BJR	Flip Chip 30 (2.0 x 2.4 mm)	Tape and reel

---

# Contents

<b>1</b>	<b>Pin settings</b> .....	<b>3</b>
	1.1 Pin connection .....	3
	1.2 Pin description .....	3
<b>2</b>	<b>Logic diagram</b> .....	<b>5</b>
<b>3</b>	<b>Maximum ratings</b> .....	<b>6</b>
	Recommended operating conditions .....	6
<b>4</b>	<b>Electrical characteristics</b> .....	<b>7</b>
<b>5</b>	<b>Test circuits</b> .....	<b>12</b>
<b>6</b>	<b>Package information</b> .....	<b>16</b>
<b>7</b>	<b>Revision history</b> .....	<b>19</b>

# 1 Pin settings

## 1.1 Pin connection

Figure 1. Pin connection

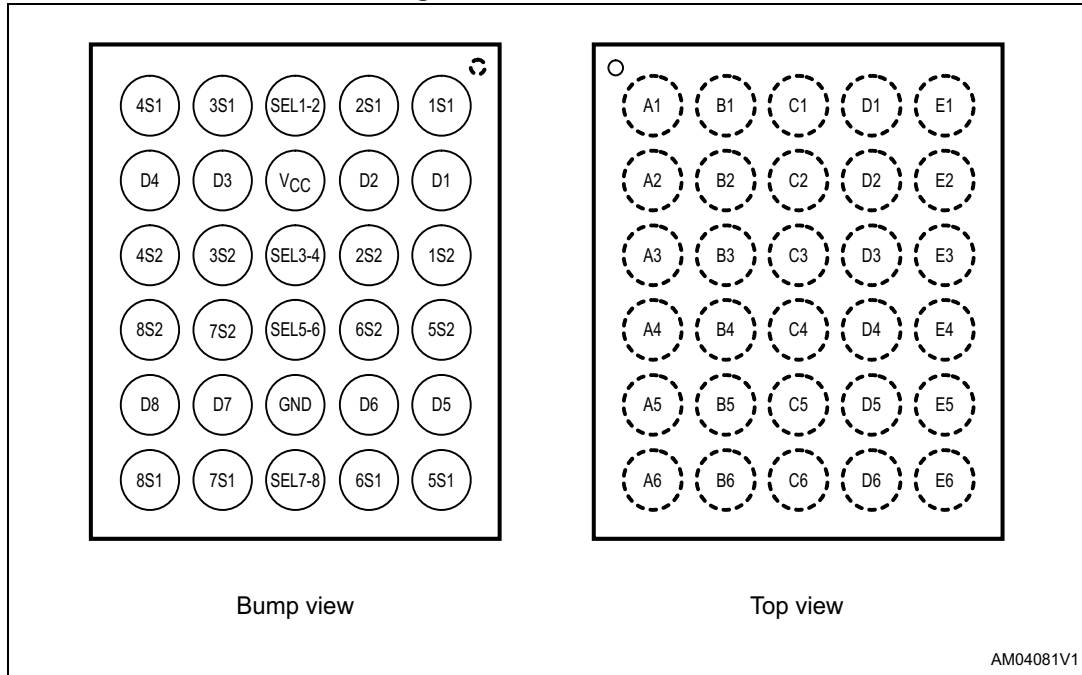

AM04081V1

## 1.2 Pin description

Table 2. Pin assignment

Pin number	Symbol	Name and function
A1	1S1	Independent channel for switch 1
A2	D1	Common channel for switch 1
A3	1S2	Independent channel for switch 1
A4	5S2	Independent channel for switch 5
A5	D5	Common channel for switch 5
A6	5S1	Independent channel for switch 5
B1	2S1	Independent channel for switch 2
B2	D2	Common channel for switch 2
B3	2S2	Independent channel for switch 2
B4	6S2	Independent channel for switch 6
B5	D6	Common channel for switch 6
B6	6S1	Independent channel for switch 6

Table 2. Pin assignment (continued)

Pin number	Symbol	Name and function
C1	SEL1-2	Switch 1-2 selection control
C2	VCC	Positive supply voltage
C3	SEL3-4	Switch 3-4 selection control
C4	SEL5-6	Switch 5-6 selection control
C5	GND	Ground (0 V)
C6	SEL7-8	Switch 7-8 selection control
D1	3S1	Independent channel for switch 3
D2	D3	Common channel for switch 3
D3	3S2	Independent channel for switch 3
D4	7S2	Independent channel for switch 7
D5	D7	Common channel for switch 7
D6	7S1	Independent channel for switch 7
E1	4S1	Independent channel for switch 4
E2	D4	Common channel for switch 4
E3	4S2	Independent channel for switch 4
E4	8S2	Independent channel for switch 8
E5	D8	Common channel for switch 8
E6	8S1	Independent channel for switch 8



### 3 Maximum ratings

Stressing the device above the rating listed in [Table 4: Absolute maximum ratings](#) may cause permanent damage to the device. These are stress ratings only and operation of the device at these or any other conditions above those indicated in [Table 5: Recommended operating conditions](#) of this specification is not implied. Exposure to absolute maximum ratings conditions for extended periods may affect device reliability.

**Table 4. Absolute maximum ratings**

Symbol	Parameter	Value	Unit
$V_{CC}$	Supply voltage	-0.5 to 6.0	V
$V_I$	DC input voltage	-0.5 to $V_{CC} + 0.5$	V
$V_{IC}$	DC control input voltage	-0.5 to 5.5	V
$V_O$	DC output voltage	-0.5 to $V_{CC} + 0.5$	V
$I_{IKC}$	DC input diode current on control pin ( $V_{SEL} < 0$ V)	-50	mA
$I_{IK}$	DC input diode current ( $V_{SEL} < 0$ V)	$\pm 50$	mA
$I_{OK}$	DC output diode current	$\pm 20$	mA
$I_O$	DC output current	$\pm 128$	mA
$I_{OP}$	DC output current peak (pulse at 1 ms, 10% duty cycle)	$\pm 300$	mA
$I_{CC}$ or $I_{GND}$	DC $V_{CC}$ or ground current	$\pm 100$	mA
$P_D$	Power dissipation at $T_A = 70$ °C	1120	mW
$T_{stg}$	Storage temperature	-65 to +150	°C
$T_L$	Lead temperature (10 sec.)	300	°C

### Recommended operating conditions

**Table 5. Recommended operating conditions**

Symbol	Parameter	Value	Unit	
$V_{CC}$	Supply voltage	1.65 to 4.3	V	
$V_I$	Input voltage	0 to $V_{CC}$	V	
$V_{IC}$	Control input voltage	0 to 4.3	V	
$V_O$	Output voltage	0 to $V_{CC}$	V	
$T_{op}$	Operating temperature	-40 to 85	°C	
dt/dv	Input rise and fall time control input	$V_L = 1.65$ V to 2.7 V	0 to 20	ns/V
		$V_L = 3.0$ V to 4.3 V	0 to 10	

## 4 Electrical characteristics

Table 6. DC specifications

Symbol	Parameter	V <sub>CC</sub> (V)	Test conditions	Value					Unit
				T <sub>A</sub> = 25 °C			-40 to 85 °C		
				Min.	Typ.	Max.	Min.	Max.	
V <sub>IH</sub>	High level input voltage	1.65 – 1.95		0.65	–	–	0.65	–	V
		2.3 – 2.5		V <sub>CC</sub>	–	–	V <sub>CC</sub>	–	
		2.7 – 3.0		1.2	–	–	1.2	–	
		3.3 – 3.6		1.3	–	–	1.3	–	
		4.3		1.4	–	–	1.4	–	
V <sub>IL</sub>	Low level input voltage	1.65 – 1.95		–	–	0.25	–	0.25	V
		2.3 – 2.5		–	–	0.25	–	0.25	
		2.7 – 3.0		–	–	0.25	–	0.25	
		3.3 – 3.6		–	–	0.30	–	0.30	
		4.3		–	–	0.40	–	0.40	
R <sub>PEAK</sub>	Switch ON peak resistance	1.8	V <sub>S</sub> = 0 V to V <sub>CC</sub> I <sub>S</sub> = 8 mA	–	17.0	19.6	–	–	Ω
		2.7		–	7.5	8.7	–	–	
		3.0		–	6.6	7.6	–	–	
		3.7		–	5.8	6.7	–	–	
		4.3		–	5.4	6.2	–	–	
R <sub>ON</sub>	Switch ON resistance	3.0	V <sub>S</sub> = 3 V I <sub>S</sub> = 8 mA	–	5.1	5.8	–	–	Ω
		3.0	V <sub>S</sub> = 0.4 V I <sub>S</sub> = 8 mA	–	6.3	7.3	–	–	
ΔR <sub>ON</sub>	ON resistance match between channels <sup>(1)</sup>	1.8	V <sub>S</sub> at R <sub>ON</sub> MAX I <sub>S</sub> = 8 mA	–	–	–	–	–	Ω
		2.7		–	–	–	–	–	
		3.0		–	0.3	–	–	–	
		3.7		–	–	–	–	–	
		4.3		–	–	–	–	–	

Table 6. DC specifications (continued)

Symbol	Parameter	V <sub>CC</sub> (V)	Test conditions	Value					Unit
				T <sub>A</sub> = 25 °C			-40 to 85 °C		
				Min.	Typ.	Max.	Min.	Max.	
R <sub>FLAT</sub>	ON resistance flatness <sup>(2)</sup>	1.8	V <sub>S</sub> = 0 V to 0.4 V I <sub>S</sub> = 8 mA	–	4.5	–	–	–	Ω
		1.8	V <sub>S</sub> = 0 V to V <sub>CC</sub> I <sub>S</sub> = 8 mA	–	9.5	–	–	–	
		2.7		–	2.2	–	–	–	
		3.0		–	1.8	–	–	–	
		3.7		–	1.6	–	–	–	
		4.3		–	1.6	–	–	–	
I <sub>OFF</sub>	OFF state leakage current (Sn), (D)	4.3	V <sub>S</sub> = 0.3 or 4 V	-20	–	20	-100	100	nA
I <sub>IN</sub>	Input leakage current	0 to 4.3	V <sub>SEL</sub> = 0 to 4.3 V	-0.2	–	0.2	-1.0	1.0	μA
I <sub>CC</sub>	Quiescent supply current	1.65 to 4.3	V <sub>SEL</sub> = V <sub>CC</sub> or GND	-0.2	–	0.2	-1.0	1.0	μA
I <sub>CCLV</sub>	Quiescent supply current for low voltage driving <sup>(3)</sup>	4.3	V <sub>SEL</sub> = 1.65 V	–	±37	±50	–	±100	μA
			V <sub>SEL</sub> = 1.80 V	–	±33	±40	–	±50	
			V <sub>SEL</sub> = 2.60 V	–	±11	±20	–	±30	

1. ΔR<sub>ON</sub> = max. |mSN - nSN|, where m = 1 to 8 and n = 1 to 8, N = 1, 2.
2. Flatness is defined as the difference between the maximum and minimum value of on-resistance as measured over the specified analog signal ranges.
3. Measurement is for one SEL pin.



Table 7. AC electrical characteristics ( $C_L = 35 \text{ pF}$ ,  $R_L = 50 \text{ } \Omega$ ,  $t_r = t_f \leq 5 \text{ ns}$ )

Symbol	Parameter	$V_{CC}$ (V)	Test conditions	Value					Unit
				$T_A = 25 \text{ } ^\circ\text{C}$			$-40 \text{ to } 85 \text{ } ^\circ\text{C}$		
				Min.	Typ.	Max.	Min.	Max.	
$t_{PLH}$ , $t_{PHL}$	Propagation delay	1.65 - 1.95		–	0.21	–	–	–	ns
		2.3 - 2.7		–	0.15	–	–		
		3.0 - 3.3		–	0.14	–	–		
		3.6 - 4.3		–	0.13	–	–		
$t_{ON}$	Turn-on time	1.65 - 1.95	$V_S = 0.8 \text{ V}$	–	36	–	–	–	ns
		2.3 - 2.7	$V_S = 1.5 \text{ V}$	–	20	23	–	26	
		3.0 - 3.3		–	15	17	–	20	
		3.6 - 4.3		–	13	15	–	17	
$t_{OFF}$	Turn-off time	1.65 - 1.95	$V_S = 0.8 \text{ V}$	–	29	–	–	–	ns
		2.3 - 2.7	$V_S = 1.5 \text{ V}$	–	19	22	–	25	
		3.0 - 3.3		–	14	16	–	18	
		3.6 - 4.3		–	11	13	–	14	
$t_D$	Break-before-make time delay	1.65 - 1.95	$C_L = 35 \text{ pF}$ $R_L = 50 \text{ } \Omega$ $V_S = 1.5 \text{ V}$	–	10	–	–	–	ns
		2.3 - 2.7		–	7	–	–		
		3.0 - 3.3		–	6	–	–		
		3.6 - 4.3		–	4	–	–		
Q	Charge injection	1.65	$C_L = 100 \text{ pF}$ $V_{GEN} = 0 \text{ V}$ $R_{GEN} = 0 \text{ } \Omega$	–	3.9	–	–	–	pC
		2.3		–	4.8	–	–		
		3.0		–	5.2	–	–		
		4.3		–	6.4	–	–		

Table 8. AC electrical characteristics ( $C_L = 5 \text{ pF}$ ,  $R_L = 50 \text{ } \Omega$ ,  $T_A = 25 \text{ } ^\circ\text{C}$ )

Symbol	Parameter	$V_{CC}$ (V)	Test conditions	Value					Unit
				$T_A = 25 \text{ } ^\circ\text{C}$			$-40 \text{ to } 85 \text{ } ^\circ\text{C}$		
				Min.	Typ.	Max.	Min.	Max.	
OIRR	OFF isolation <sup>(1)</sup>	1.65 – 4.3	$V_S = 1 \text{ V}_{RMS}$ , $f = 1 \text{ MHz}$ signal = 0 dBm	–	-78	–	–	–	dB
			$V_S = 1 \text{ V}_{RMS}$ , $f = 10 \text{ MHz}$ signal = 0 dBm	–	-57	–	–	–	
Xtalk	Crosstalk	1.65 – 4.3	$V_S = 1 \text{ V}_{RMS}$ , $f = 1 \text{ MHz}$ signal = 0 dBm	–	-78	–	–	–	dB
			$V_S = 1 \text{ V}_{RMS}$ , $f = 10 \text{ MHz}$ signal = 0 dBm	–	-58	–	–	–	
BW	-3dB bandwidth	3.0 – 4.3	$R_L = 50 \text{ } \Omega$ signal = 0 dBm	–	800	–	–	–	MHz
$C_{IN}$	Control pin input capacitance		$V_{CC} = 0 \text{ V}$	–	2	–	–	–	pF
$C_{Sn}$	Sn port capacitance	3.3	F = 240 MHz, switch is enabled	–	6	–	–	–	pF
			F = 240 MHz, switch is disabled	–	2	–	–	–	
$C_D$	D port capacitance	3.3	F = 240 MHz	–	8	–	–	–	pF

1. Off isolation =  $20 \text{ Log}_{10} (V_D/V_S)$ ,  $V_D$  = output,  $V_S$  = input to off switch.

Table 9. USB related AC electrical characteristics

Symbol	Parameter	V <sub>CC</sub> (V)	Test conditions	Value					Unit
				T <sub>A</sub> = 25 °C			-40 to 85 °C		
				Min.	Typ.	Max.	Min.	Max.	
t <sub>SK(0)</sub>	Channel-to-channel skew	3.0 - 3.6	C <sub>L</sub> = 10 pF	–	26	–	–	–	ps
t <sub>SK(P)</sub>	Skew of opposite transition of the same output	3.0 - 3.6	C <sub>L</sub> = 10 pF	–	60	–	–	–	ps
T <sub>J</sub>	Total jitter	3.0 - 3.6	R <sub>L</sub> = 50 Ω C <sub>L</sub> = 10 pF t <sub>R</sub> = t <sub>F</sub> = 750 ps at 480 Mbps	–	130	–	–	–	ps

# 5 Test circuits

Figure 3. On-resistance

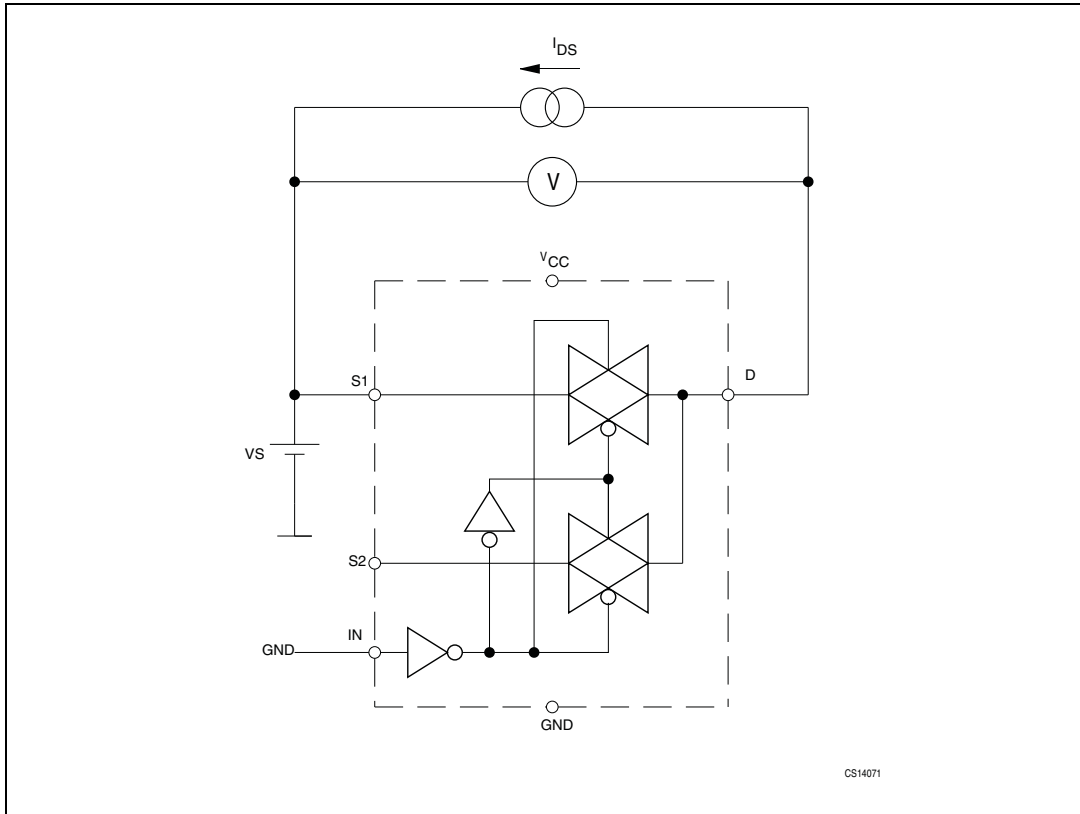

Figure 4. Bandwidth

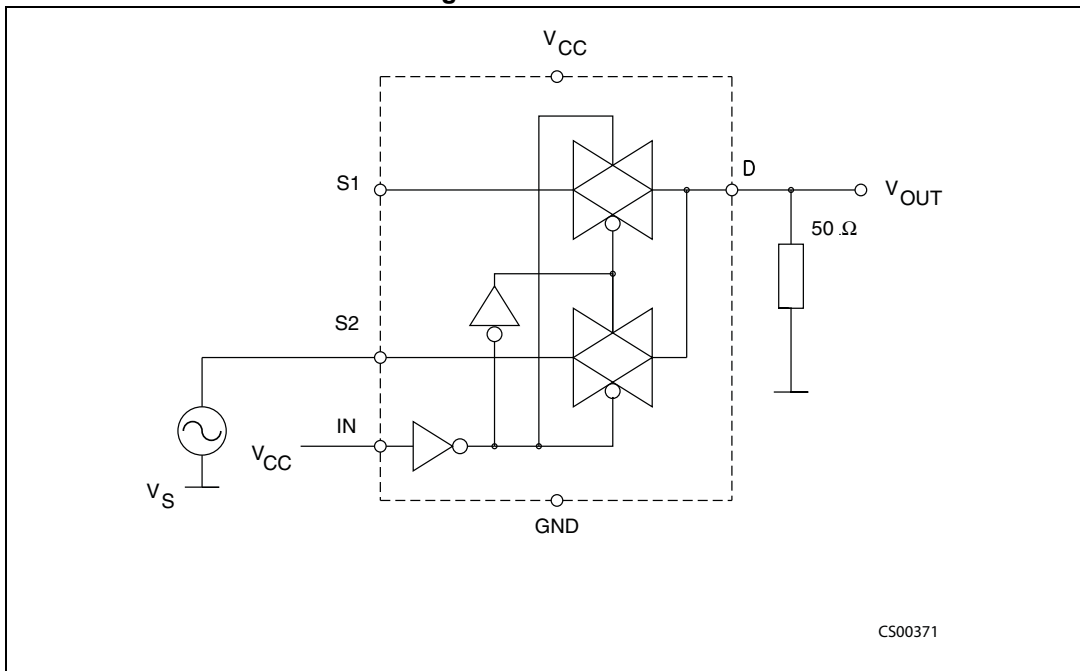

Figure 5. Off leakage

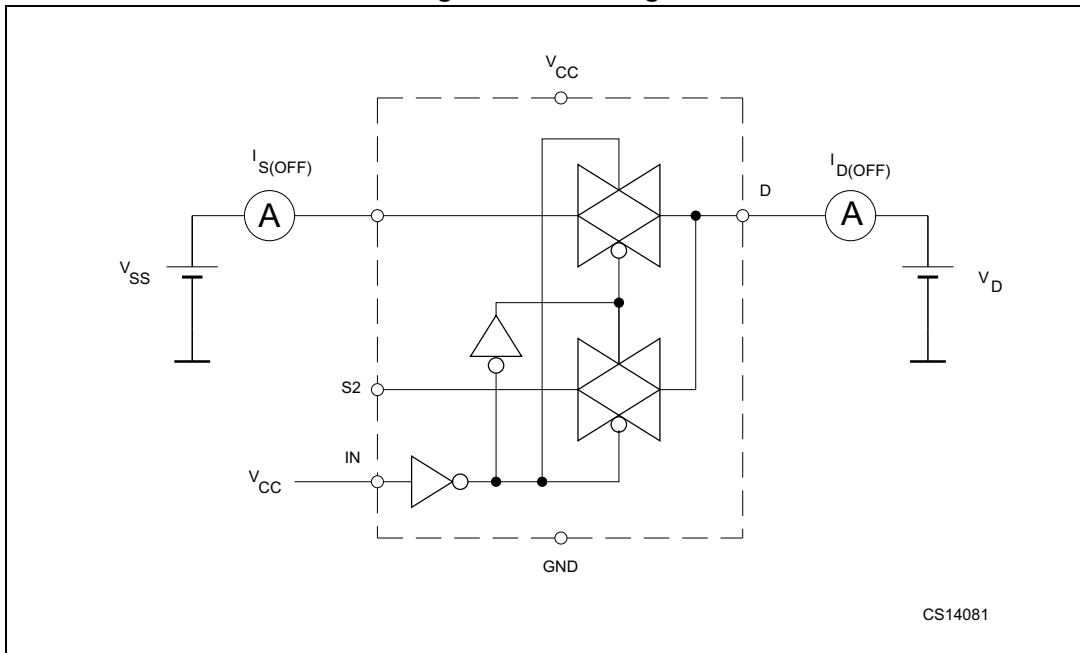

Figure 6. Channel to channel crosstalk

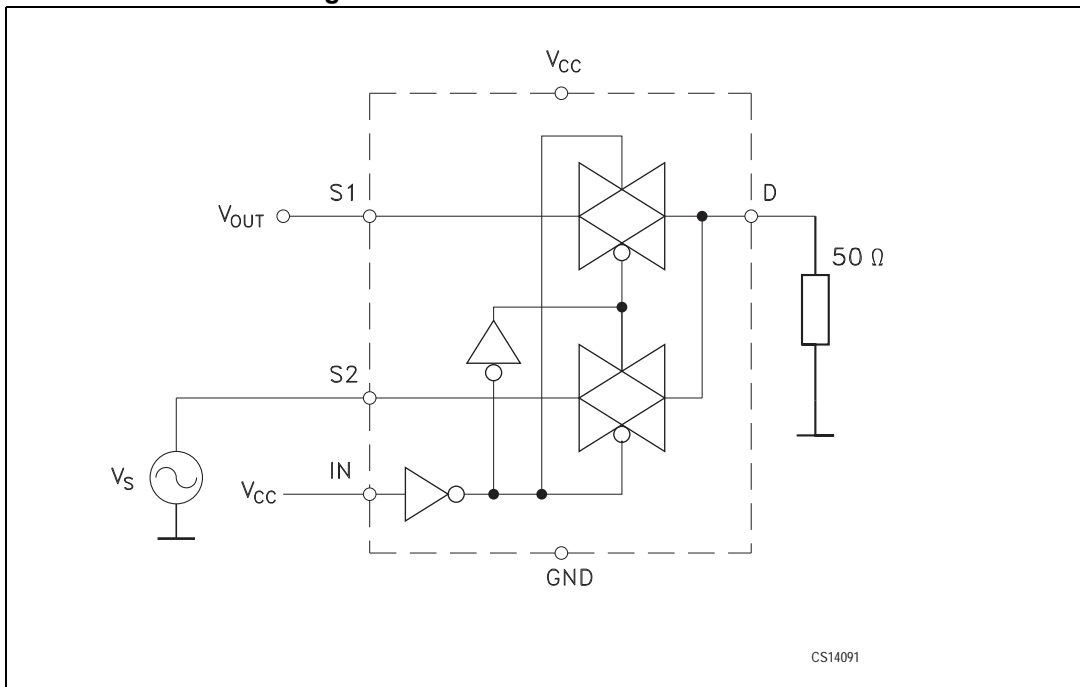

Figure 7. Off isolation

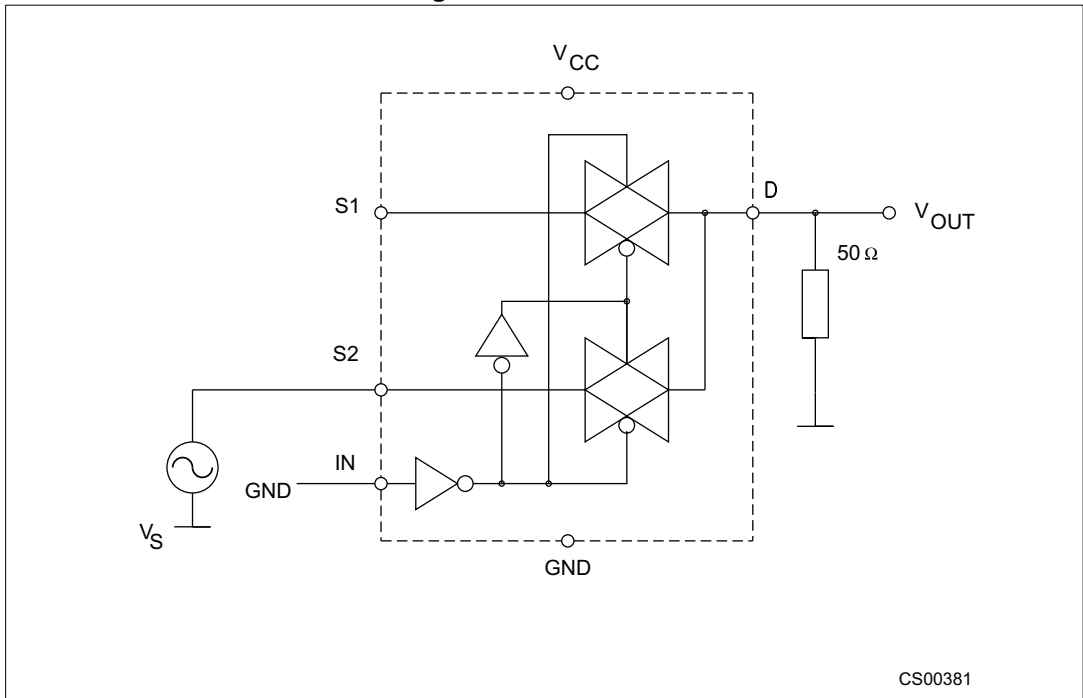
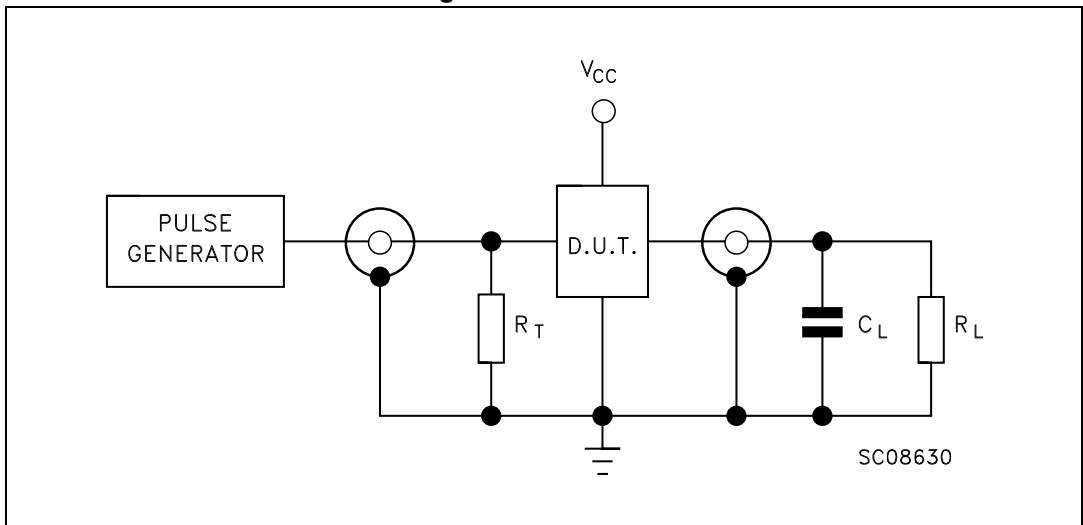

Figure 8. Test circuit



Note:  $C_L = 5/35\text{ pF}$  or equivalent: (includes jig capacitance).  
 $R_L = 50\ \Omega$  or equivalent.  
 $R_T = Z_{OUT}$  of pulse generator (typically  $50\ \Omega$ ).

Figure 9. Break-before-make time delay

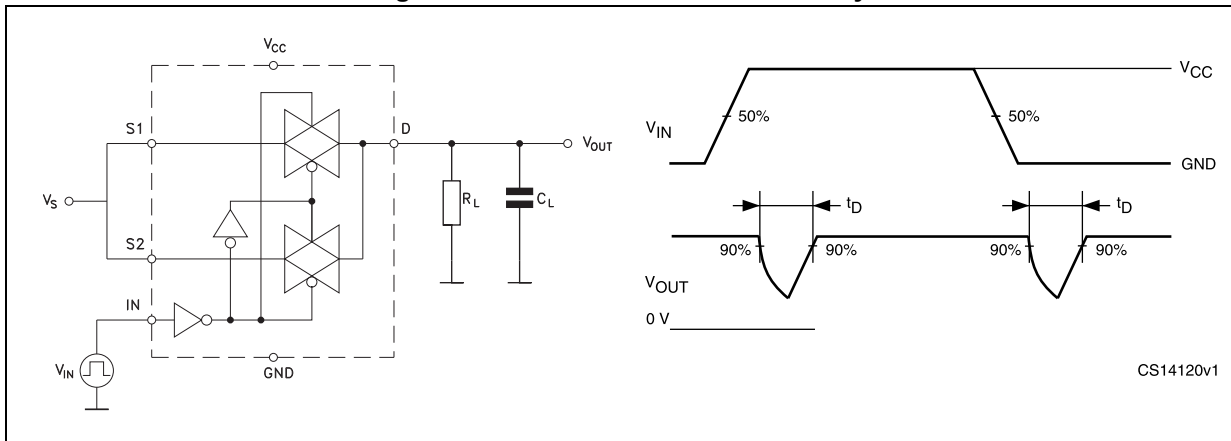

Figure 10. Switching time and charge injection ( $V_{GEN} = 0\text{ V}$ ,  $R_{GEN} = 0\ \Omega$ ,  $R_L = 1\text{ M}\Omega$ ,  $C_L = 100\text{ pF}$ )

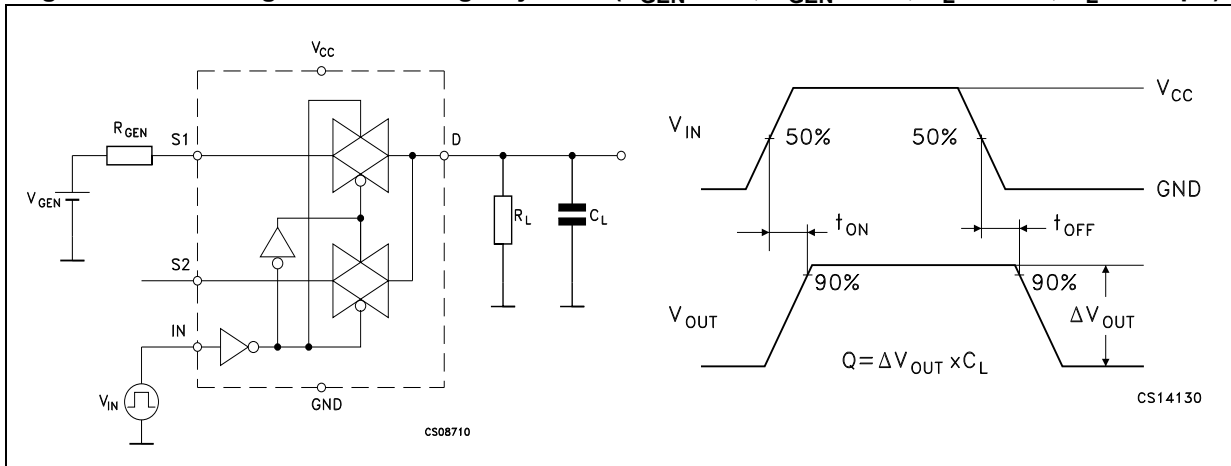
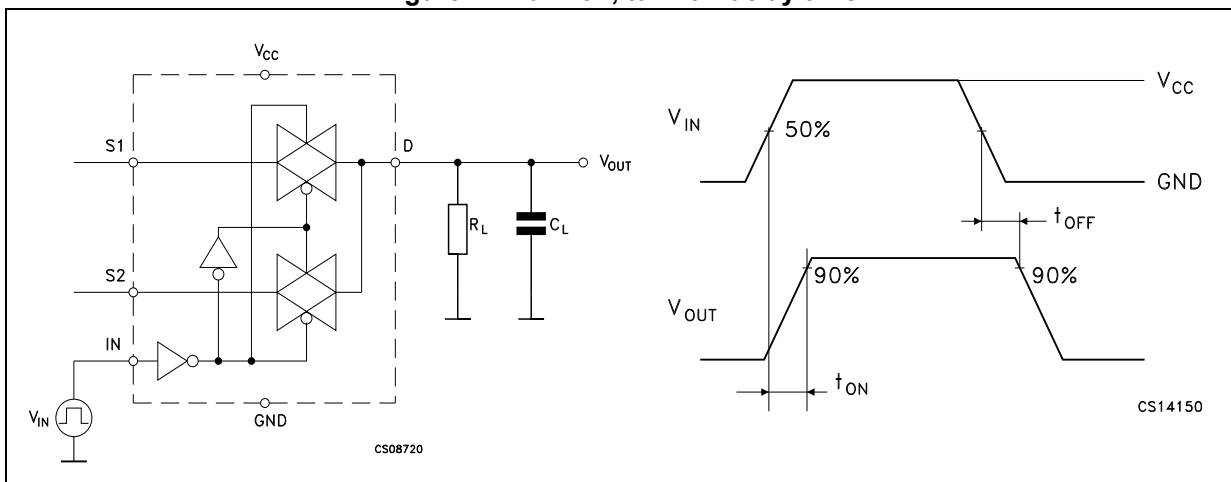

Figure 11. Turn-on, turn-off delay time



## 6 Package information

In order to meet environmental requirements, ST offers these devices in different grades of ECOPACK<sup>®</sup> packages, depending on their level of environmental compliance. ECOPACK specifications, grade definitions and product status are available at: [www.st.com](http://www.st.com). ECOPACK is an ST trademark.

**Figure 12. Package outline for Flip Chip 30 (2.0 x 2.4 x 0.625 mm) - 0.4 mm pitch**

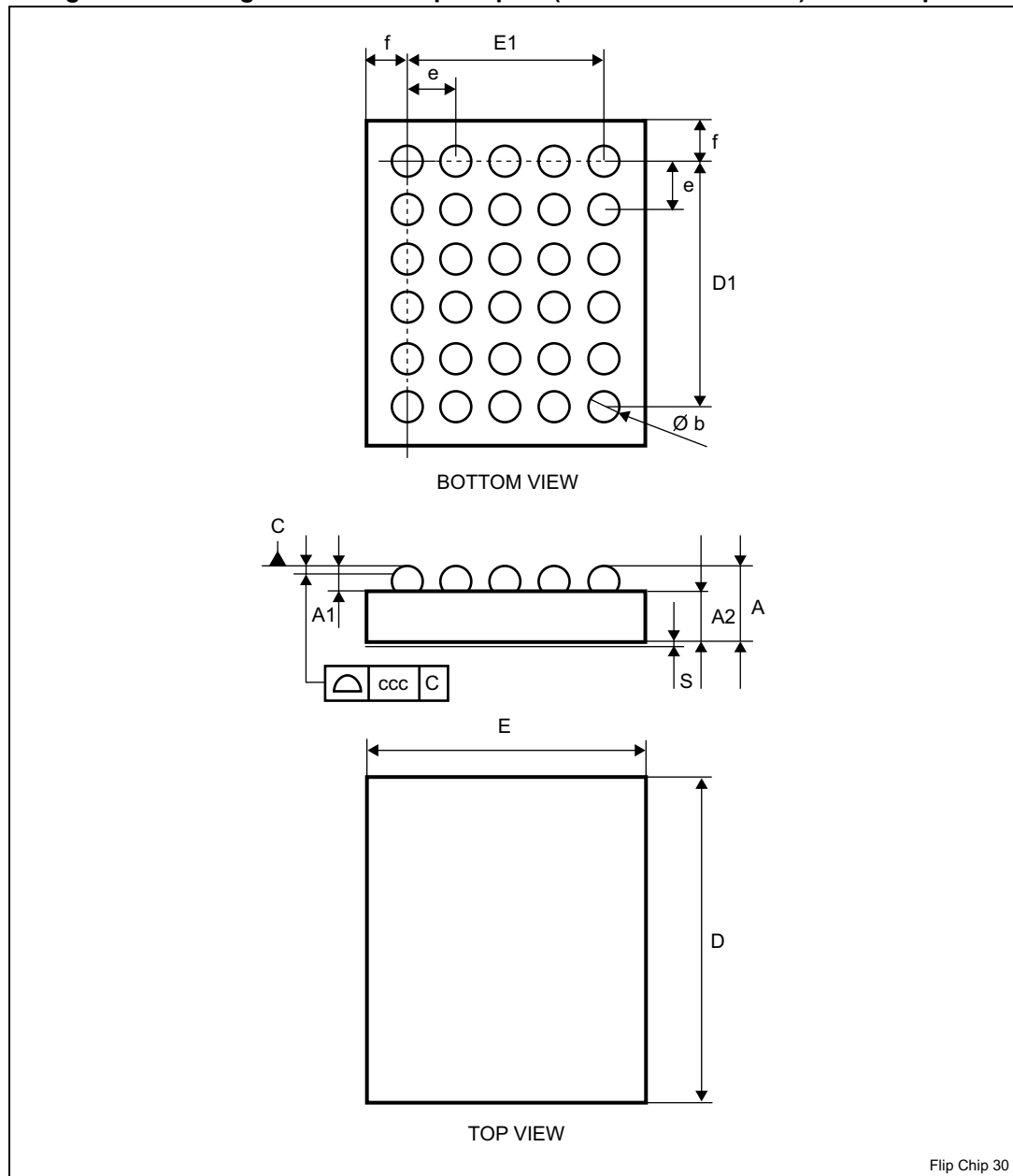



**Table 10. Mechanical data for Flip Chip 30 (2.0 x 2.4 x 0.625 mm) - 0.4 mm pitch**

Symbol	Dimensions (mm)		
	Min.	Typ.	Max.
A	0.565	0.625	0.685
A1	0.17	0.205	0.24
A2	0.355	0.375	0.395
b	0.215	0.255	0.295
D	2.1	2.4	2.43
D1	–	2.0	–
E	1.97	2.0	2.03
E1	–	1.6	–
e	0.36	0.4	0.44
f	0.19	0.2	0.21
ccc	–	0.05	–
\$	0.040	0.045	0.05

**Figure 13. Footprint recommendations for Flip Chip 30 (2.0 x 2.4 x 0.625 mm) - 0.4 mm pitch**

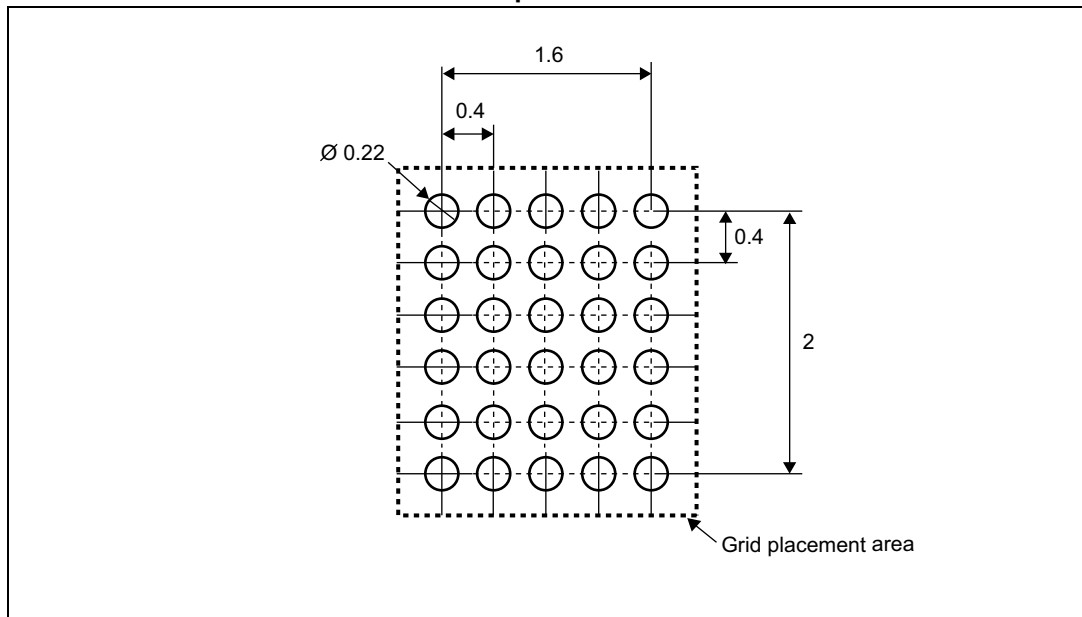

Figure 14. Tape information for Flip Chip 30 (2.0 x 2.4 x 0.625 mm) - 0.4 mm pitch

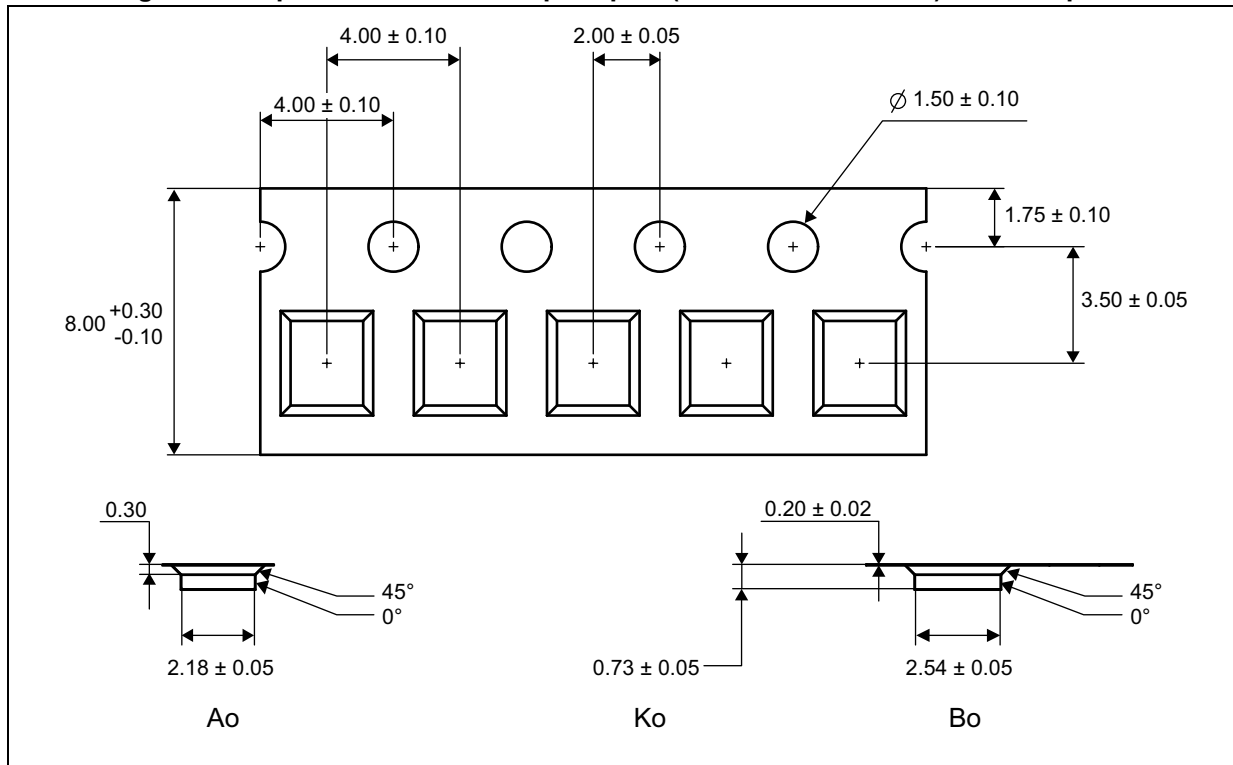
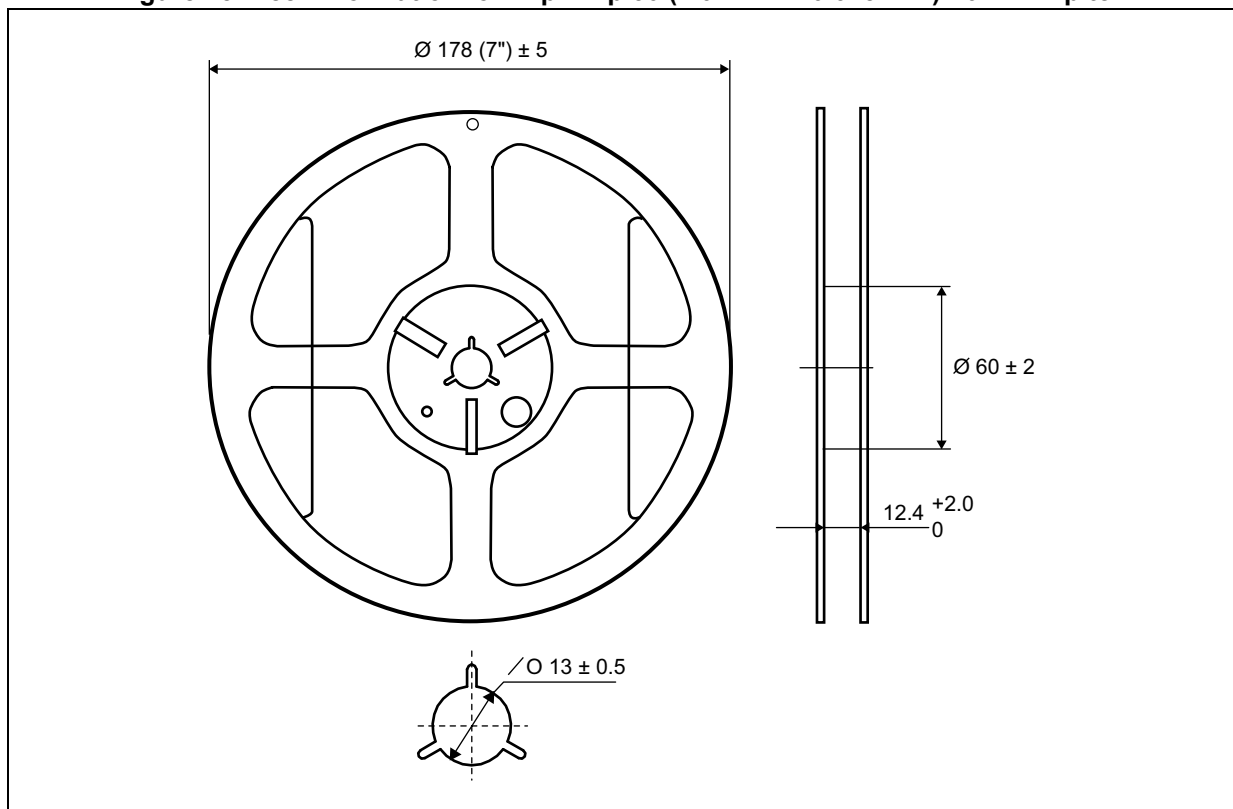

Figure 15. Reel information for Flip Chip 30 (2.0 x 2.4 x 0.625 mm) - 0.4 mm pitch



## 7 Revision history

**Table 11. Document revision history**

Date	Revision	Changes
18-Dec-2009	1	Initial release.
19-Jan-2011	2	Document reformatted, added <a href="#">Contents</a> , updated <a href="#">Figure 12</a> and <a href="#">Figure 13</a> , corrected typo in <a href="#">Features</a> , <a href="#">Table 1</a> , <a href="#">Section 1: Pin settings</a> , <a href="#">Table 2</a> , <a href="#">Table 7</a> , <a href="#">Table 8</a> , notes below <a href="#">Figure 8</a> , title of <a href="#">Figure 11</a> , <a href="#">Figure 12</a> , <a href="#">Table 10</a> , and <a href="#">Figure 13</a> , corrected name of "Table 11" to <a href="#">Figure 13</a> .
23-Apr-2013	3	Moved <a href="#">Description</a> to page 1. Redrawn <a href="#">Figure 1</a> . Updated <a href="#">Section 3</a> (added/updated cross-references, updated $V_{CC}$ value in <a href="#">Table 4</a> ). Redrawn <a href="#">Figure 12</a> to <a href="#">Figure 15</a> . Updated <a href="#">Figure 12</a> (removed superfluous reference to note). Updated title of <a href="#">Figure 14</a> and <a href="#">Figure 15</a> (added "Flip Chip 30 (2.0 x 2.4 x 0.625 mm) - 0.4 mm pitch"). Minor corrections throughout document.
06-Aug-2013	4	Updated <a href="#">Table 8 on page 10</a> (replaced $C_{ON}$ and $C_{OFF}$ symbol by $C_{sn}$ and $C_D$ symbol).

**Please Read Carefully:**

Information in this document is provided solely in connection with ST products. STMicroelectronics NV and its subsidiaries ("ST") reserve the right to make changes, corrections, modifications or improvements, to this document, and the products and services described herein at any time, without notice.

All ST products are sold pursuant to ST's terms and conditions of sale.

Purchasers are solely responsible for the choice, selection and use of the ST products and services described herein, and ST assumes no liability whatsoever relating to the choice, selection or use of the ST products and services described herein.

No license, express or implied, by estoppel or otherwise, to any intellectual property rights is granted under this document. If any part of this document refers to any third party products or services it shall not be deemed a license grant by ST for the use of such third party products or services, or any intellectual property contained therein or considered as a warranty covering the use in any manner whatsoever of such third party products or services or any intellectual property contained therein.

**UNLESS OTHERWISE SET FORTH IN ST'S TERMS AND CONDITIONS OF SALE ST DISCLAIMS ANY EXPRESS OR IMPLIED WARRANTY WITH RESPECT TO THE USE AND/OR SALE OF ST PRODUCTS INCLUDING WITHOUT LIMITATION IMPLIED WARRANTIES OF MERCHANTABILITY, FITNESS FOR A PARTICULAR PURPOSE (AND THEIR EQUIVALENTS UNDER THE LAWS OF ANY JURISDICTION), OR INFRINGEMENT OF ANY PATENT, COPYRIGHT OR OTHER INTELLECTUAL PROPERTY RIGHT.**

**ST PRODUCTS ARE NOT AUTHORIZED FOR USE IN WEAPONS. NOR ARE ST PRODUCTS DESIGNED OR AUTHORIZED FOR USE IN: (A) SAFETY CRITICAL APPLICATIONS SUCH AS LIFE SUPPORTING, ACTIVE IMPLANTED DEVICES OR SYSTEMS WITH PRODUCT FUNCTIONAL SAFETY REQUIREMENTS; (B) AERONAUTIC APPLICATIONS; (C) AUTOMOTIVE APPLICATIONS OR ENVIRONMENTS, AND/OR (D) AEROSPACE APPLICATIONS OR ENVIRONMENTS. WHERE ST PRODUCTS ARE NOT DESIGNED FOR SUCH USE, THE PURCHASER SHALL USE PRODUCTS AT PURCHASER'S SOLE RISK, EVEN IF ST HAS BEEN INFORMED IN WRITING OF SUCH USAGE, UNLESS A PRODUCT IS EXPRESSLY DESIGNATED BY ST AS BEING INTENDED FOR "AUTOMOTIVE, AUTOMOTIVE SAFETY OR MEDICAL" INDUSTRY DOMAINS ACCORDING TO ST PRODUCT DESIGN SPECIFICATIONS. PRODUCTS FORMALLY ESCC, QML OR JAN QUALIFIED ARE DEEMED SUITABLE FOR USE IN AEROSPACE BY THE CORRESPONDING GOVERNMENTAL AGENCY.**

Resale of ST products with provisions different from the statements and/or technical features set forth in this document shall immediately void any warranty granted by ST for the ST product or service described herein and shall not create or extend in any manner whatsoever, any liability of ST.

ST and the ST logo are trademarks or registered trademarks of ST in various countries.

Information in this document supersedes and replaces all information previously supplied.

The ST logo is a registered trademark of STMicroelectronics. All other names are the property of their respective owners.

© 2013 STMicroelectronics - All rights reserved

STMicroelectronics group of companies

Australia - Belgium - Brazil - Canada - China - Czech Republic - Finland - France - Germany - Hong Kong - India - Israel - Italy - Japan - Malaysia - Malta - Morocco - Philippines - Singapore - Spain - Sweden - Switzerland - United Kingdom - United States of America

[www.st.com](http://www.st.com)