

## Isc N-Channel MOSFET Transistor

## STD15NF10T4

## • FEATURES

- With To-252(DPAK) package
- Application oriented characterization
- Excellent switching performance
- 100% avalanche tested
- Minimum Lot-to-Lot variations for robust device performance and reliable operation

## • APPLICATIONS

- Switching applications

• ABSOLUTE MAXIMUM RATINGS( $T_a=25^{\circ}\text{C}$ )

SYMBOL	PARAMETER	VALUE	UNIT
$V_{DSS}$	Drain-Source Voltage	100	V
$V_{GSS}$	Gate-Source Voltage	$\pm 20$	V
$I_D$	Drain Current-Continuous@ $T_c=25^{\circ}\text{C}$ ( $T_j=175^{\circ}\text{C}$ ) $T_c=125^{\circ}\text{C}$	23 16	A
$I_{DM}$	Drain Current-Single Pulsed	92	A
$P_D$	Total Dissipation @ $T_c=25^{\circ}\text{C}$	70	W
$T_{ch}$	Max. Operating Junction Temperature	175	$^{\circ}\text{C}$
$T_{stg}$	Storage Temperature	-55~175	$^{\circ}\text{C}$

## • THERMAL CHARACTERISTICS

SYMBOL	PARAMETER	MAX	UNIT
$R_{th(ch-c)}$	Channel-to-case thermal resistance	2.14	$^{\circ}\text{C}/\text{W}$
$R_{th(ch-a)}$	Channel-to-ambient thermal resistance	100	$^{\circ}\text{C}/\text{W}$

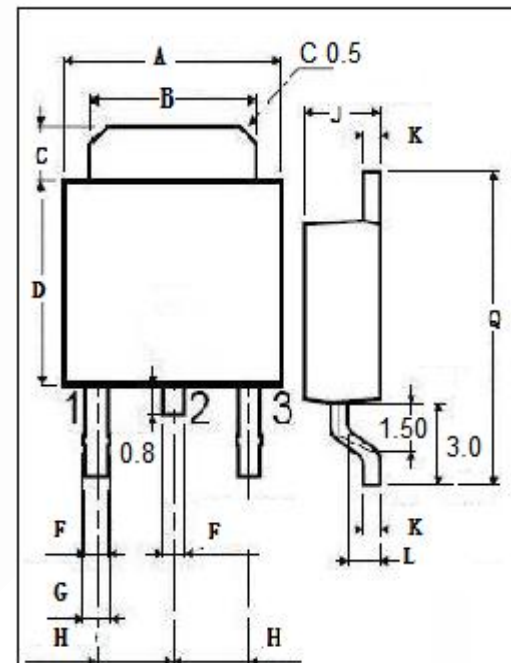
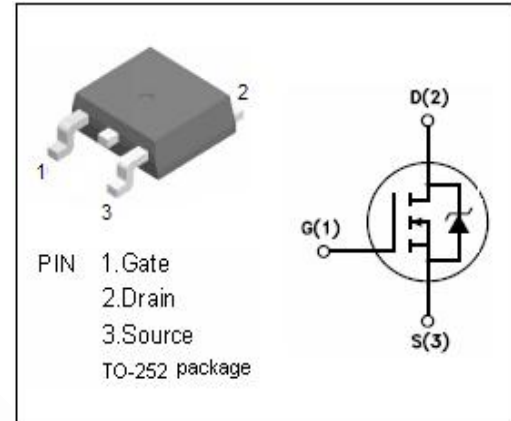

DIM	mm	
	MIN	MAX
A	6.40	6.60
B	5.20	5.40
C	1.15	1.35
D	5.70	6.10
F	0.65	
G	0.75	
H	2.10	2.50
J	2.10	2.40
K	0.40	0.60
L	0.90	1.10
Q	9.90	10.1

**Isc N-Channel MOSFET Transistor****STD15NF10T4****ELECTRICAL CHARACTERISTICS**T<sub>C</sub>=25°C unless otherwise specified

SYMBOL	PARAMETER	CONDITIONS	MIN	TYP	MAX	UNIT
BV <sub>DSS</sub>	Drain-Source Breakdown Voltage	V <sub>GS</sub> =0V; I <sub>D</sub> = 0.25mA	100			V
V <sub>GS(th)</sub>	Gate Threshold Voltage	V <sub>DS</sub> = ±20V; I <sub>D</sub> =0.25mA	2		4	V
R <sub>DS(on)</sub>	Drain-Source On-Resistance	V <sub>GS</sub> = 10V; I <sub>D</sub> =12A		60	65	mΩ
I <sub>GSS</sub>	Gate-Source Leakage Current	V <sub>GS</sub> = ±20V; V <sub>DS</sub> = 0V			±0.1	μA
I <sub>DSS</sub>	Drain-Source Leakage Current	V <sub>DS</sub> = 100V; V <sub>GS</sub> = 0V; T <sub>J</sub> =25°C T <sub>J</sub> =125°C			1 10	μA
V <sub>SDF</sub>	Diode forward voltage	I <sub>SD</sub> =20A, V <sub>GS</sub> = 0 V			1.5	V