

Flexible GPS/Galileo/Glonass/QZSS receiver with high performance processing (ARM9)

Data brief – production data

Features

- STMicroelectronics® 3rd generation positioning receiver with 32 tracking channels and 2 fast acquisition channels compatible with GPS, Galileo, Glonass and QZSS systems
- Embedded RF front-end with built-in LNA
- -162dBm indoor sensitivity (tracking mode)
- Fast TTFF < 1 s in hot start and 35 s in cold start
- Support of ST-AGPSTM Multimode Assisted GPS (extended ephemeris solution)
- High performance ARM946 MCU (up to 208 MHz)
- 256 Kbyte embedded TCM/SRAM
- FSMC external memory interface (NAND, NOR and SRAM)
- External SQI Flash interface
- One 16-bit Extended Function Timer (EFT) with input capture/ output compare and PWM.
- Four 32-bit free running timers/ counters
- Real Time Clock (RTC) circuit
- 3 UARTs (one full for modem support)
- 1 I²C master/slave interface
- 1 Synchronous Serial Port (SSP, Motorola-SPI supported)
- USB2.0 dual role full speed (12 MHz) with integrated physical layer transceiver
- 2 Secure-Digital Multimedia Memory Card Interfaces (SDMMC)
- 2 Controller Area Network (CAN)
- 1 Multichannel Serial Port (MSP)
- GPIO port for a total of up to 64 GPIOs
- 8-channels ADC (10 bit)

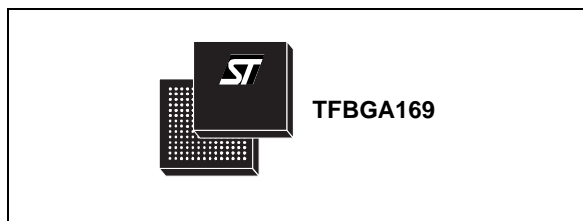

- Selectable 1.8 V or 3.3 V I/Os for specific I/O ports
- 3 embedded 1.8 V voltage regulators
- Operating condition:
 - V_{DD12}: 1.2 V ±10 %
 - V_{DD18/RF18}: 1.8 V ±5 %
 - V_{LPVR}: 1.62 V to 3.6 V
 - V_{ddIO}: 1.8 V -5 %/ +10 %; 3.3 V ±10 %
- Package:
 - TFBGA169 9 x 9 x 1.2 mm 0.65 pitch
 - TFBGA169 12 x 12 x 1.2 mm 0.8 pitch
- Ambient temperature range: -40/ +85 °C

Description

STA8088EXG is a single die standalone positioning receiver IC working on multiple constellations (GPS/Galileo/Glonass/QZSS).

By combining the ARM946 microcontroller core with the large number of peripherals/ interfaces, STA8088EXG provides a highly-flexible and cost effective solution for hand-held and telematic applications.

The device is the ideal solution for sensor-based and sensor-less ST Dead Reckoning technologies which enhance positioning accuracy even in areas without GNSS signals, like tunnels and indoor parking.

Contents

1	Overview	5
2	Pin description	6
2.1	Block diagram	6
2.2	TFBGA169 ball out	7
2.3	Power supply pins	9
2.4	Main function pins	10
2.5	Test / emulated dedicated pins	10
2.6	FSMC external memory interface pins	11
2.7	SQI pins	11
2.8	Port 0 pins	12
2.9	Port 1 pins	15
2.10	RF front-end pins	17
3	Package and packing information	18
3.1	ECOPACK [®] packages	18
3.2	TFBGA169 9 x 9 x 1.2 mm package information	18
3.3	TFBGA169 12 x 12 x 1.2 mm package information	20
4	Ordering information	22
5	Revision history	23

List of tables

Table 1.	TFBGA169 ball out Automotive Grade (with CAN)	7
Table 2.	TFBGA169 ball out (no CAN)	8
Table 3.	Power supply pins	9
Table 4.	Main function pins	10
Table 5.	Test/emulated dedicated pins	10
Table 6.	FSMC memory interface pins	11
Table 7.	SQI pins	11
Table 8.	Port 0 pins	12
Table 9.	Port 1 pins	15
Table 10.	RF front-end pins	17
Table 11.	TFBGA169 9 x 9 x 1.2 mm mechanical data	18
Table 12.	TFBGA169 12 x 12 x 1.2 mm mechanical data	20
Table 13.	Document revision history	23

List of figures

Figure 1.	STA8088EXG system block diagram	6
Figure 2.	TFBGA169 9 x 9 x 1.2 mm package dimension	19
Figure 3.	TFBGA169 12 x 12 x 1.2 mm package dimension	21
Figure 4.	Ordering information scheme	22

1 Overview

STA8088EXG is an integrated System-On-Chip device designed for a highly-flexible and cost effective solution for vehicle, hand-held navigation and telematic applications.

It combines a high performance ARM946 microprocessor with embedded enhanced peripherals and I/O capabilities, RF front-end and base band processor to support GPS, Galileo, Glonass and QZSS satellite systems.

It also provides clock generation via PLL, backup logic with real time clock and it supports USB2.0 standard at full speed.

STA8088EXG is software compatible with the ARM processor family. The device is power supplied with 1.8 V and uses three on-chip voltage regulators to internally supply the RF front-end, core logic the backup logic. In order to reduce the power consumption the chip can be directly powered with 1.2 V bypassing the embedded voltage regulators.

I/O lines are compatible with 1.8 V and 3.3 V.

The chip, using STMicroelectronics CMOSRF technology, is housed in a TFBGA169 (9 x 9 x 1.2 mm) and TFBGA169 (12 x 12 x 1.2 mm) packages.

The Automotive Grade devices (see [Figure 4: Ordering information scheme](#)) fulfilling high quality and service level automotive market requirements, is the ideal solution for OEM telematic applications.

2 Pin description

2.1 Block diagram

Figure 1. STA8088EXG system block diagram

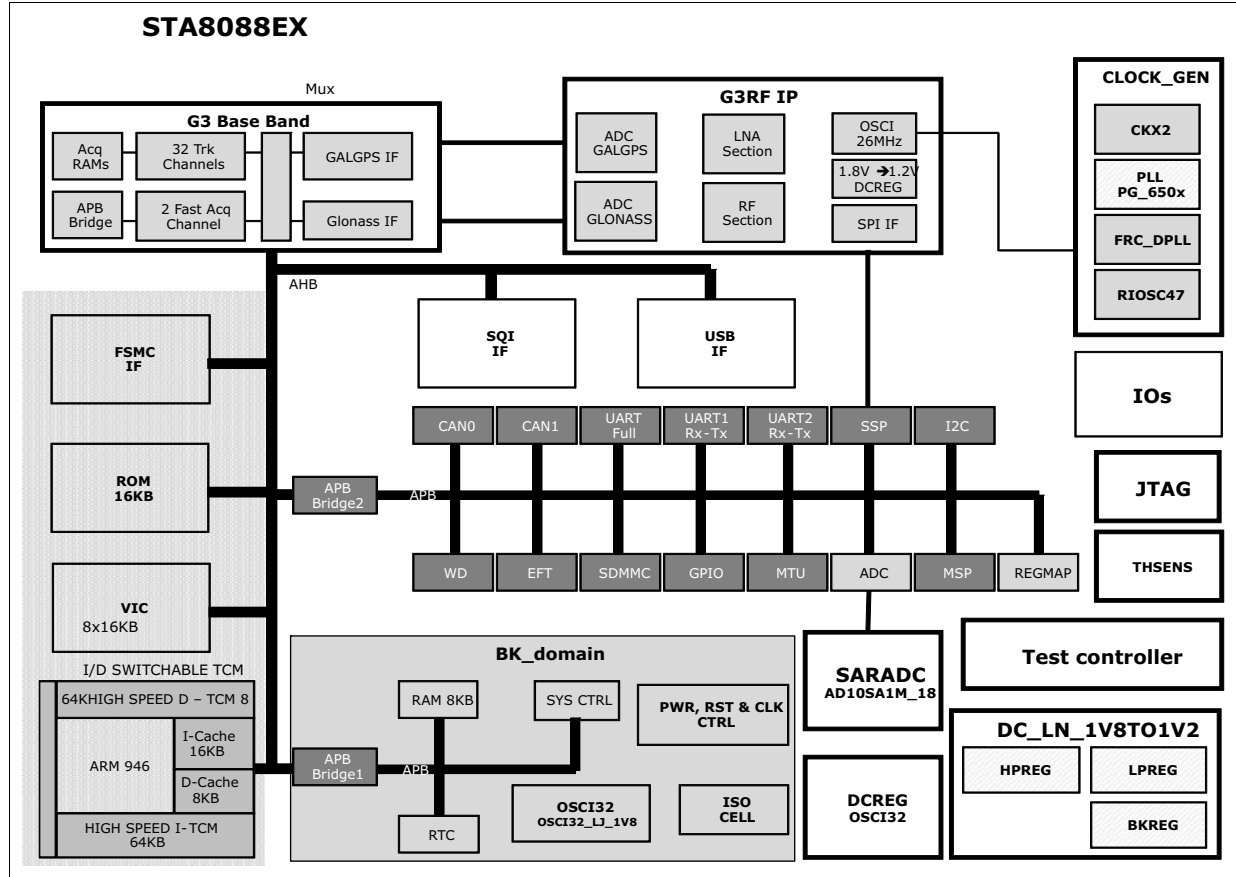



2.2 TFBGA169 ball out

Table 1. TFBGA169 ball out Automotive Grade (with CAN)

	1	2	3	4	5	6	7	8	9	10	11	12	13
A	GNDIO	USB_DM (UART1_RX)	USB_DP (UART1_TX)	CAN0TX	FSMC ADD22 (P1.30)	FSMC ADD18 (P1.26)	FSMC ADD9 (P1.17)	FSMC ADD16 (P1.24)	FSMC DATA15	FSMC DATA8	FSMC DATA5	FSMC DATA4	GNDIO
B	VDDIO_r2	CAN1TX (P0.8)	CAN1RX (P0.9)	CAN0RX	FSMC ADD23 (P1.31)	FSMC ADD19 (P1.27)	FSMC ADD6 (P1.14)	FSMC ADD10 (P1.18)	FSMC DATA14	FSMC DATA2	VDDIO_r3	FSMC BLn1	FSMC BLn0
C	MSPOUT SCLK (P0.31)	MSPOUT LRCLK (P0.30)	MSPOUT_SD/ Iopwrse1_r2 (P0.29)	VDDIO_r5	FSMC WTn	FSMC ADD20 (P1.28)	FSMC ADD1 (P1.9)	FSMC ADD14 (P1.22)	FSMC DATA12	FSMC DATA10	FSMC CS2	FSMC_CS3/ Iopwrse1_r3	FSMC DATA0
D	MMC_CLK	MMC_CMD (P0.28)	VDD18 MVR	VDD12_MVR	FSMC WEN	FSMC ADD21 (P1.29)	FSMC ADD2 (P1.10)	FSMC ADD11 (P1.19)	FSMC CLK	FSMC ADV	FSMC DATA9	FSMC CS1	FSMC CS0
E	MMC_D0 (P0.20)	MMC_D1 (P0.21)	MMC_D2 (P0.22)	MMC_D3 (P0.23)	FSMC OutEN	FSMC ADD4 (P1.12)	FSMC ADD7 (P1.15)	FSMC ADD17 (P1.25)	FSMC ADD13 (P1.21)	FSMC DATA1	FSMC DATA3	GPIO2 (P0.2)	GPIO5 (P0.5)
F	MMC_D4 (P0.24)	MMC_D5 (P0.25)	MMC_D6 (P0.26)	MMC_D7 (P0.27)	FSMC ADD5 (P1.13)	FSMC ADD3 (P1.11)	FSMC ADD0 (P1.8)	FSMC ADD8 (P1.16)	FSMC ADD12 (P1.20)	FSMC DATA7	SPI_CLK (P1.1)	GPIO1 (P0.1)	GPIO4 (P0.4)
G	TMS	TRSTn	TDI	TCK	GND	GND	GND	VDD18 MVR	FSMC DATA11	FSMC DATA6	SPI_DO (P1.3)	VDDIO_r1	GPIO7 (P0.7)
H	VRF12 RFADC	TP_IF_P	GND_RF	TDO	VDD12 LPVR	GNDIO	GND	GND	FSMC ADD15 (P1.23)	FSMC DATA13	SPI_DI (P1.2)	GPIO3 (P0.3)	GPIO6 (P0.6)
J	VRF12 LNA	TP_IF_N	GND_RF	GND_RF	STBY_OUT	STBYn	VDD12_MVR	VDD LPVR	VDD12_MVR	PPS_OUT	SPI_CSN/ Iopwrse1_r1 (P1.0)	UART0 RTS (P0.14)	GPIO0 (P0.0)
K	LNA IN	GND LNA	GND_RF	GND_RF	GND_RF	GND_RF	WAKEUP	RSTn	ADC_IN8	VDDIO_r4	UART2_TX/ BOOT_0 (P1.5)	UART2_RX (P1.4)	UART0_TX/ BOOT_1 (P1.7)
L	GND LNA	GND LNA	GND_RF	GND_RF	VRF12 RFVCO	VRF12 RFDIG	ADC_IN1	ADC_IN4	ADC_IN2	SQI_SIO2 (P0.12)	SQI_SCK	UART0 DTR (P0.18)	UART0_RX (P1.6)
M	LNA OUT	VRF18 RFVCR	GND_RF	GND_RF	VRF12 MIX	XTAL OUT	ADC_IN3	ADC_IN6	RTC_XTI	SQI_SIO1 (P0.11)	SQI_Cen/ Iopwrse1_r4 (P0.19)	UART0 CTS (P0.15)	UART0 DSR (P0.16)
N	GND_RF	VRF12OUT RFVCR	VRF12 RFA	RFA IN	VRF12_IF	XTAL IN	ADC_IN7	ADC_IN5	RTC_XTO	SQI_SIO3 (P0.13)	SQI_SIO0 (P0.10)	UART0 DCD (P0.17)	GNDIO

**Table 2. TFBGA169 ball out (no CAN)**

	1	2	3	4	5	6	7	8	9	10	11	12	13
A	GNDIO	USB_DM (UART1_RX)	USB_DP (UART1_TX)	N.C.	FSMC ADD22 (P1.30)	FSMC ADD18 (P1.26)	FSMC ADD9 (P1.17)	FSMC ADD16 (P1.24)	FSMC DATA15	FSMC DATA8	FSMC DATA5	FSMC DATA4	GNDIO
B	VDDIO_r2	I2C_SD (P0.8)	I2C_SCLK (P0.9)	N.C.	FSMC ADD23 (P1.31)	FSMC ADD19 (P1.27)	FSMC ADD6 (P1.14)	FSMC ADD10 (P1.18)	FSMC DATA14	FSMC DATA2	VDDIO_r3	FSMC BLn1	FSMC BLn0
C	MSPOUT SCLK (P0.31)	MSPOUT LRCLK (P0.30)	MSPOUT_SD/ Iopwrsel_r2 (P0.29)	VDDIO_r5	FSMC WTn	FSMC ADD20 (P1.28)	FSMC ADD1 (P1.9)	FSMC ADD14 (P1.22)	FSMC DATA12	FSMC DATA10	FSMC CS2	FSMC_CS3/ Iopwrsel_r3	FSMC DATA0
D	MMC_CLK	MMC_CMD (P0.28)	VDD18 MVR	VDD12_MVR	FSMC WEN	FSMC ADD21 (P1.29)	FSMC ADD2 (P1.10)	FSMC ADD11 (P1.19)	FSMC CLK	FSMC ADV	FSMC DATA9	FSMC CS1	FSMC CS0
E	MMC_D0 (P0.20)	MMC_D1 (P0.21)	MMC_D2 (P0.22)	MMC_D3 (P0.23)	FSMC OutEN	FSMC ADD4 (P1.12)	FSMC ADD7 (P1.15)	FSMC ADD17 (P1.25)	FSMC ADD13 (P1.21)	FSMC DATA1	FSMC DATA3	GPIO2 (P0.2)	GPIO5 (P0.5)
F	MMC_D4 (P0.24)	MMC_D5 (P0.25)	MMC_D6 (P0.26)	MMC_D7 (P0.27)	FSMC ADD5 (P1.13)	FSMC ADD3 (P1.11)	FSMC ADD0 (P1.8)	FSMC ADD8 (P1.16)	FSMC ADD12 (P1.20)	FSMC DATA7	SPI_CLK (P1.1)	GPIO1 (P0.1)	GPIO4 (P0.4)
G	TMS	TRSTn	TDI	TCK	GND	GND	GND	VDD18 MVR	FSMC DATA11	FSMC DATA6	SPI_DO (P1.3)	VDDIO_r1	GPIO7 (P0.7)
H	VRF12 RFADC	TP_IF_P	GND_RF	TDO	VDD12 LPVR	GNDIO	GND	GND	FSMC ADD15 (P1.23)	FSMC DATA13	SPI_DI (P1.2)	GPIO3 (P0.3)	GPIO6 (P0.6)
J	VRF12 LNA	TP_IF_N	GND_RF	GND_RF	STBY_OUT	STDBYn	VDD12_MVR	VDD LPVR	VDD12_MVR	PPS_OUT	SPI_CSN/ IOpwrsel_r1 (P1.0)	UART0 RTS (P0.14)	GPIO0 (P0.0)
K	LNA IN	GND LNA	GND_RF	GND_RF	GND_RF	GND_RF	WAKEUP	RSTn	ADC_IN8	VDDIO_r4	UART2_TX/ BOOT_0 (P1.5)	UART2_RX (P1.4)	UART0_TX/ BOOT_1 (P1.7)
L	GND LNA	GND LNA	GND_RF	GND_RF	VRF12 RFVCO	VRF12 RFDIG	ADC_IN1	ADC_IN4	ADC_IN2	SQI_SIO2 (P0.12)	SQI_SCK	UART0 DTR (P0.18)	UART0_RX (P1.6)
M	LNA OUT	VRF18 RFVVR	GND_RF	GND_RF	VRF12 MIX	XTAL OUT	ADC_IN3	ADC_IN6	RTC_XT1	SQI_SIO1 (P0.11)	SQI_Cen/ Iopwrsel_r4 (P0.19)	UART0 CTS (P0.15)	UART0 DSR (P0.16)
N	GND_RF	VRF12OUT RFVVR	VRF12 RFA	RFA IN	VRF12_IF	XTAL IN	ADC_IN7	ADC_IN5	RTC_XTO	SQI_SIO3 (P0.13)	SQI_SIO0 (P0.10)	UART0 DCD (P0.17)	GNDIO

2.3 Power supply pins

Table 3. Power supply pins

Symbol	I/O	Functions	TFBGA169
VDD18_MVR	Pwr	Digital supply voltage for main voltage regulator (1.8 V)	D3, G8
VDD12_MVR	Pwr	Digital supply voltage for core circuitry (1.2 V). When using the MVR, this pin shall not be driven by an external voltage supply, but a capacitance shall be connected between these pins and GND to guarantee on-chip voltage stability.	J7, D4, J9
VDD_LPVR	Pwr	Digital supply voltage for low power voltage regulator (1.62 V - 3.6 V)	J8
VDD12_LPVR	Pwr	Digital supply voltage for backup logic (1.2 V). When using the LPVR, this pin shall not be driven by an external voltage supply, but a capacitance shall be connected between these pins and GND to guarantee on-chip voltage stability.	H5
VDD_IOR1	Pwr	Digital supply voltage for I/O ring 1 (1.8 V or 3.3 V)	G12
VDD_IOR2	Pwr	Digital supply voltage for I/O ring 2 (1.8 V or 3.3 V)	B1
VDD_IOR3	Pwr	Digital supply voltage for I/O ring 3 (1.8 V or 3.3 V)	B11
VDD_IOR4	Pwr	Digital supply voltage for I/O ring 4 (1.8 V or 3.3 V)	K10
VDD_IOR5	Pwr	Digital supply voltage for I/O ring 5 (3.3 V)	C4
VRF18_RFVR	Pwr	Analog supply voltage for RF voltage regulator (1.8 V)	M2
GND	GND	Digital supply ground for core (5 pins)	G5, G6, G7, H7, H8
GND_IO	GND	Digital supply ground for I/O circuitry (4 pins)	A1, A13, H6, N13
VRF12OUT_RFVR	Pwr	RF voltage regulator 1.2 V output	N2
VRF12_LNA	Pwr	Analog supply voltage for LNA (1.2 V)	J1
VRF12_RFA	Pwr	Analog supply voltage for RFA (1.2 V)	N3
VRF12_Mix	Pwr	Analog supply voltage for Mixer (1.2 V)	M5
VRF12_IF	Pwr	Analog supply voltage for IF (1.2 V)	N5
VRF12_RFDig	Pwr	Analog supply voltage for RF Digital (1.2 V)	L6
VRF12_RFVCO	Pwr	Analog supply voltage for VCO (1.2 V)	L5
VRF12_RFADC	Pwr	Analog supply voltage for RF ADC (1.2 V)	H1
GND_LNA	GND	Analog supply ground for LNA (3 pins)	K2, L1, L2
GND_RF	GND	Analog supply ground to RF (12 pins)	H3, J3, J4, K3, K4, K5, K6, L3, L4, M3, M4, N1

2.4 Main function pins

Table 4. Main function pins

Symbol	I/O voltage	I/O	Functions	TFBGA169
RSTn	1.2 V	I	Reset Input with Schmitt-Trigger characteristics and noise filter.	K8
STDBYn	1.2 V	I	When low, the chip is forced in Standby mode. All pins in high impedance except the ones powered by backup supply	J6
WAKEUP	1.2 V	I	WAKEUP from STANDBY mode	K7
STDBY_Out	1.2 V	O	When low, indicates the chip is in Standby mode.	J5
PPS_Out	VDD_IOR1	O	Pulsed per second output	J10
RTC_XTI	1.5 V (max)	I	Input of the 32 KHz oscillator amplifier circuit and input of the internal real time clock circuit.	M9
RTC_XTO	1.5 V (max)	O	Output of the oscillator amplifier circuit.	N9
CAN0TX ⁽¹⁾	VDD_IOR5	O	CAN 0 - transmit data output	A4
CAN0RX ⁽¹⁾	VDD_IOR5	I	CAN 0 - receive data input	B4
USB_DM/UART1_RX	VDD_IOR5	USB/I	USB D- signal / UART 1 Rx data	A2
USB_DP/UART1_TX	VDD_IOR5	USB/O	USB D+ signal / UART 1 Tx data	A3
ADC_IN[1:8]	1.4 V – 0 V typ range	I	ADC analog input [1:8]	L7, L9, M7, L8, N8, M8, N7, K9
MMC_CLK	VDD_IOR2	O	MMC_CLK: multimedia clock line	D1

1. Only for Automotive Grade devices.

2.5 Test / emulated dedicated pins

Table 5. Test/emulated dedicated pins

Symbol	I/O Voltage	I/O	Functions	TFBGA169
TCK	VDD_IOR5	I	JTAG test clock	G4
TDI	VDD_IOR5	I	JTAG test data in	G3
TDO	VDD_IOR5	O	JTAG test data out	H4
TMS	VDD_IOR5	I	JTAG test mode select	G1
TRSTn	VDD_IOR5	I	JTAG test circuit reset	G2
TP_IF_P	VRF12_IF	O	Diff. test point for IF – positive	H2
TP_IF_N	VRF12_IF	O	Diff. test point for IF – negative	J2

2.6 FSMC external memory interface pins

Table 6. FSMC memory interface pins

Symbol	I/O Voltage	I/O	Functions	TFBGA169
FSMC_Data[15:0]	VDD_IOR3	I/O	FSMC EMI data bus	C13, E10, B10, E11, A12, A11, G10, F10, A10, D11, C10, G9, C9, H10, B9, A9
FSMC_Add[23:0] ⁽¹⁾⁽²⁾	VDD_IOR3	O	FSMC EMI address bus	F7, C7, D7, F6, E6, F5, B7, E7, F8, A7, B8, D8, F9, E9, C8, H9, A8, E8, A6, B6, C6, D6, A5, B5
FSMC_OutEN	VDD_IOR3	O	FSMC EMI output enable	E5
FSMC_WEN	VDD_IOR3	O	FSMC EMI write enable	D5
FSMC_WTn	VDD_IOR3	I	FSMC EMI wait (SNOR, CRAM)	C5
FSMC_BLn[0,1]	VDD_IOR3	O	FSMC EMI byte lane	B13, B12
FSMC_CLK	VDD_IOR3	O	FSMC EMI clk	D9
FSMC_ADV	VDD_IOR3	O	FSMC EMI address valid	D10
FSMC_CS0	VDD_IOR3	O	FSMC EMI chip select for external memory bank 0	D13
FSMC_CS1	VDD_IOR3	O	FSMC EMI chip select for external memory bank 1	D12
FSMC_CS2	VDD_IOR3	O	FSMC EMI chip select for external memory bank 2	C11
FSMC_CS3/ iopwrsel_r3	VDD_IOR3	O	FSMC EMI chip select for external memory bank 3 / I/O ring 3 power selection	C12

1. FSMC_Add[23:0] are multiplexed with P1[31:8] - see [Table 9](#)
2. In case of NAND memory usage the
FSMC_Add16 is used as CLE
FSMC_Add17 is used as ALE

2.7 SQI pins

Table 7. SQI pins

Symbol	I/O Voltage	I/O	Functions	TFBGA169
SQI_SIO3	VDD_IOR4	I/O	SQI Flash data I/O 3	N10
SQI_SIO2	VDD_IOR4	I/O	SQI Flash data I/O 2	L10
SQI_SIO1/SO	VDD_IOR4	I/O	SQI Flash data I/O 1 / ser. O	M10
SQI_SIO0/SI	VDD_IOR4	I/O	SQI Flash data I/O 0 / ser. I	N11

Table 7. SQUI pins (continued)

Symbol	I/O Voltage	I/O	Functions	TFBGA169
SQUI_SCK	VDD_IOR4	O	SQUI Flash clock	L11
SQUI_CEn/ iopwrse1_r4	VDD_IOR4	O	SQUI Flash chip enable / I/O ring 4 power selection	M11

SQUI pins are multiplexed with P0[13:10] and P0[19] (see [Table 8](#)).

2.8 Port 0 pins

Port 0 consists of a 32-bit bidirectional I/O port. It can be either used as general purpose input or output port, or configured according to the associated alternate functions.

Table 8. Port 0 pins

Symbol	I/O voltage	I/O	Mode	Functions	TFBGA169
P0.0	VDD_IOR1	I/O	Default	GPIO.0: general purpose I/O	J13
		I	A	PPS_IN: pulse per second input	
		O	B	PPS_Out: pulse per second output	
		O	C	SQUI_CEn: SQUI Flash chip enable	
P0.1	VDD_IOR1	I/O	Default	GPIO.1: general purpose I/O	F12
		O	A	RTC_CLKO: RTC clock out	
P0.2	VDD_IOR1	I/O	Default	GPIO.2: general purpose I/O	E12
		O	A	MMC2_CLK: MMC 2 clock line	
P0.3	VDD_IOR1	I/O	Default	GPIO.3: general purpose I/O	H12
		I/O	A	MMC2_CMD: MMC 2 command line	
P0.4	VDD_IOR1	I/O	Default	GPIO.4: general purpose I/O	F13
		I/O	A	MMC2_DATA3: MMC 2 data 3	
P0.5	VDD_IOR1	I/O	Default	GPIO.5: general purpose I/O	E13
		I/O	A	MMC2_DATA2: MMC 2 data 2	
P0.6	VDD_IOR1	I/O	Default	GPIO.6: general purpose I/O	H13
		I/O	A	MMC2_DATA1: MMC 2 data 1	
P0.7	VDD_IOR1	I/O	Default	GPIO.7: general purpose I/O	G13
		I/O	A	MMC2_DATA0: MMC 2 data 0	
P0.8	VDD_IOR5	O	Default	CAN1TX ⁽¹⁾ : CAN 1 transmit data output	B2
		I/O	A	GPIO.8: general purpose I/O	
		I/O	B	I2C_SD: I2C serial data	

Table 8. Port 0 pins (continued)

Symbol	I/O voltage	I/O	Mode	Functions	TFBGA169
P0.9	VDD_IOR5	I	Default	CAN1RX ⁽¹⁾ : CAN 1 receive data input	B3
		I/O	A	GPIO.9: general purpose I/O	
		O	B	I2C_SCLK: I2C clock	
P0.10	VDD_IOR4	I/O	Default	SQI_SIO0/SI: SQI Flash data I/O 0 / ser. I	N11
		I/O	A	GPIO10: general purpose I/O	
P0.11	VDD_IOR4	I/O	Default	SQI_SIO1/SO: SQI Flash data I/O 1 / ser. O	M10
		I/O	A	GPIO11: general purpose I/O	
P0.12	VDD_IOR4	I/O	Default	SQI_SIO2: SQI Flash data I/O 2	L10
		I/O	A	GPIO12: general purpose I/O	
P0.13	VDD_IOR4	I/O	Default	SQI_SIO3: SQI Flash data I/O 3	N10
		I/O	A	GPIO13: general purpose I/O	
P0.14	VDD_IOR1	O	Default	UART0_RTS: UART0 request to send	J12
		I/O	A	GPIO14: general purpose I/O	
		I	C	MSPIN_sclk: MSP serial clock input	
P0.15	VDD_IOR1	I	Default	UART0_CTS: UART0 clear to send	M12
		I/O	A	GPIO15: general purpose I/O	
		I	B	Timer_ICAPA: extended function timer - input capture A	
		I	C	MSPIN_lrcclk: MSP left/right clock input	
P0.16	VDD_IOR1	I	Default	UART0_DSR: UART0 data set ready	M13
		I/O	A	GPIO16: general purpose I/O	
		O	B	Timer_OCMPA: extended function timer – output compare A	
		I	C	MSPIN_SD: MSP serial data input	
P0.17	VDD_IOR1	I	Default	UART0_DCD: UART0 data carrier detect	N12
		I/O	A	GPIO17: general purpose I/O	
		I	B	Timer_ICAPB: extended function timer - input capture B	
P0.18	VDD_IOR1	O	Default	UART0_DTR: UART0 data terminal read	L12
		I/O	A	GPIO18: general purpose I/O	
		O	B	Timer_OCMPB: extended function timer – output compare B	
P0.19	VDD_IOR4	O	Default	SQI_Cen/iopwrse1_r4: SQI Flash chip enable / I/O ring 4 power selection	M11
		I/O	A	GPIO19: general purpose I/O	

Table 8. Port 0 pins (continued)

Symbol	I/O voltage	I/O	Mode	Functions	TFBGA169
P0.20	VDD_IOR2	I/O	Default	MMC_DATA0: multimedia card data 0	E1
		I/O	A	GPIO20: general purpose I/O	
		O	B	MAG_0GNS: GNS 3bit coding output (MAG0)	
P0.21	VDD_IOR2	I/O	Default	MMC_DATA1: multimedia card data 1	E2
		I/O	A	GPIO21: general purpose I/O	
		O	B	MAG_1GNS: GNS 3bit coding output (MAG1)	
P0.22	VDD_IOR2	I/O	Default	MMC_DATA2: multimedia card data 2	E3
		I/O	A	GPIO22: general purpose I/O	
		I/O	B	MAG_0GGPS: GGPS 3bit coding output (MAG0)	
P0.23	VDD_IOR2	I/O	Default	MMC_DATA3: multimedia card data 3	E4
		I/O	A	GPIO23: general purpose I/O	
		I/O	B	MAG_1GGPS: GGPS 3bit coding output (MAG1)	
P0.24	VDD_IOR2	I/O	Default	MMC_DATA4: multimedia card data 4	F1
		I/O	A	GPIO24: general purpose I/O	
P0.25	VDD_IOR2	I/O	Default	MMC_DATA5: multimedia card data 5	F2
		I/O	A	GPIO25: general purpose I/O	
P0.26	VDD_IOR2	I/O	Default	MMC_DATA6: multimedia card data 6	F3
		I/O	A	GPIO26: general purpose I/O	
P0.27	VDD_IOR2	I/O	Default	MMC_DATA7: multimedia card data 7	F4
		I/O	A	GPIO27: general purpose I/O	
P0.28	VDD_IOR2	I/O	Default	MMC_CMD: multimedia card command line	D2
		I/O	A	GPIO28: general purpose I/O	
P0.29	VDD_IOR2	O	Default	MSPout_SDAT/iopwrsel_r2: MSP serial data output/ I/O ring 2 power selection	C3
		I/O	A	GPIO29: general purpose I/O	
P0.30	VDD_IOR2	O	Default	MSPout_LRCLK MSP left/right clock output	C2
		I/O	A	GPIO30: general purpose I/O	
P0.31	VDD_IOR2	O	Default	MSPout_SCLK: MSP serial clock output	C1
		I/O	A	GPIO31: general purpose I/O	
		O	B	PRNSEQ0	

1. Only for Automotive Grade devices.

2.9 Port 1 pins

Port 1 consists of a 32-bit bidirectional I/O port. It can be either used as general purpose input or output port, or configured according to the associated alternate functions.

Table 9. Port 1 pins

Symbol	I/O Voltage	I/O	Mode	Functions	TFBGA169
P1.0	VDD_IOR1	O	Default	SSP_CSN/iopwrse1_r1: SSP chip select active low / I/O ring 1 power selection	J11
		I/O	A	GPIO32: general purpose I/O	
		I/O	B	SignGGPS: GGPS 3bit coding output (Sign)	
		O	C	SQI_Cen: SQI Flash chip enable	
P1.1	VDD_IOR1	I/O	Default	SSP_CLK: SSP clock	F11
		I/O	A	GPIO33: general purpose I/O	
		I/O	B	Clock_GGPS: GGPS clock out	
		O	C	SQI_Clk: SQI Flash clock	
P1.2	VDD_IOR1	I	Default	SSP_DI: SSP serial data input	H11
		I/O	A	GPIO34: general purpose I/O	
		I/O	B	SignGNS: GNS 3bit coding output (Sign)	
		I/O	C	SQI_SIO0/SI: SQI Flash data I/O 0 / ser. I	
P1.3	VDD_IOR1	O	Default	SSP_DO: SSP serial data output	G11
		I/O	A	GPIO35: general purpose I/O	
		I/O	B	Clock_GNS: GNS clock out	
		I/O	C	SQI_SIO1/SO: SQI Flash data I/O 1 / ser. O	
P1.4	VDD_IOR1	I	Default	UART2_RX: UART 2 Rx data	K12
		I/O	A	GPIO36: general purpose I/O	
P1.5	VDD_IOR1	O	Default	UART2_TX: UART 2 Tx data / ARM Boot 0	K11
		I/O	A	GPIO37: general purpose I/O	
P1.6	VDD_IOR1	I	Default	UART0_RX: UART 0 Rx data	L13
		I/O	A	GPIO38: general purpose I/O	
		I/O	C	SQI_SIO2: SQI Flash data I/O 2	
P1.7	VDD_IOR1	O	Default	UART0_TX: UART 0 Tx data / ARM Boot 1	K13
		I/O	A	GPIO39: general purpose I/O	
		I/O	C	SQI_SIO3: SQI Flash data I/O 3	
P1.8	VDD_IOR3	O	Default	FSMC_Add0: FSMC EMI address bus 0	F7
		I/O	A	GPIO40: general purpose I/O	

Table 9. Port 1 pins (continued)

Symbol	I/O Voltage	I/O	Mode	Functions	TFBGA169
P1.9	VDD_IOR3	O	Default	FSMC_Add1: FSMC EMI address bus 1	C7
		I/O	A	GPIO41: general purpose I/O	
P1.10	VDD_IOR3	O	Default	FSMC_Add2: FSMC EMI address bus 2	D7
		I/O	A	GPIO42: general purpose I/O	
P1.11	VDD_IOR3	O	Default	FSMC_Add3: FSMC EMI address bus 3	F6
		I/O	A	GPIO43: general purpose I/O	
P1.12	VDD_IOR3	O	Default	FSMC_Add4: FSMC EMI address bus 4	E6
		I/O	A	GPIO44: general purpose I/O	
P1.13	VDD_IOR3	O	Default	FSMC_Add5: FSMC EMI address bus 5	F5
		I/O	A	GPIO45: general purpose I/O	
P1.14	VDD_IOR3	O	Default	FSMC_Add6: FSMC EMI address bus 6	B7
		I/O	A	GPIO46: general purpose I/O	
P1.15	VDD_IOR3	O	Default	FSMC_Add7: FSMC EMI address bus 7	E7
		I/O	A	GPIO47: general purpose I/O	
P1.16	VDD_IOR3	O	Default	FSMC_Add8: FSMC EMI address bus 8	F8
		I/O	A	GPIO48: general purpose I/O	
P1.17	VDD_IOR3	O	Default	FSMC_Add9: FSMC EMI address bus 9	A7
		I/O	A	GPIO49: general purpose I/O	
P1.18	VDD_IOR3	O	Default	FSMC_Add10: FSMC EMI address bus 10	B8
		I/O	A	GPIO50: general purpose I/O	
P1.19	VDD_IOR3	O	Default	FSMC_Add11: FSMC EMI address bus 11	D8
		I/O	A	GPIO51: general purpose I/O	
P1.20	VDD_IOR3	O	Default	FSMC_Add12: FSMC EMI address bus 12	F9
		I/O	A	GPIO52: general purpose I/O	
P1.21	VDD_IOR3	O	Default	FSMC_Add13: FSMC EMI address bus 13	E9
		I/O	A	GPIO53: general purpose I/O	
P1.22	VDD_IOR3	O	Default	FSMC_Add14: FSMC EMI address bus 14	C8
		I/O	A	GPIO54: general purpose I/O	
P1.23	VDD_IOR3	O	Default	FSMC_Add15: FSMC EMI address bus 15	H9
		O	A	TCXO_CLK	
P1.24	VDD_IOR3	O	Default	FSMC_Add16/CLE: FSMC EMI address bus 16/CLE	A8
		I/O	A	GPIO56: general purpose I/O	

Table 9. Port 1 pins (continued)

Symbol	I/O Voltage	I/O	Mode	Functions	TFBGA169
P1.25	VDD_IOR3	O	Default	FSMC_Add17/ALE: FSMC EMI address bus 17/ALE	E8
		I/O	A	GPIO57: general purpose I/O	
P1.26	VDD_IOR3	O	Default	FSMC_Add18: FSMC EMI address bus 18	A6
		I/O	A	GPIO58: general purpose I/O	
P1.27	VDD_IOR3	O	Default	FSMC_Add19: FSMC EMI address bus19	B6
		I/O	A	GPIO59: general purpose I/O	
P1.28	VDD_IOR3	O	Default	FSMC_Add20: FSMC EMI address bus 20	C6
		I/O	A	GPIO60: general purpose I/O	
P1.29	VDD_IOR3	O	Default	FSMC_Add21: FSMC EMI address bus 21	D6
		I/O	A	GPIO61: general purpose I/O	
P1.30	VDD_IOR3	O	Default	FSMC_Add22: FSMC EMI address bus 22	A5
		I/O	A	GPIO62: general purpose I/O	
P1.31	VDD_IOR3	O	Default	FSMC_Add23: FSMC EMI address bus 23	B5
		I/O	A	GPIO63: general purpose I/O	

2.10 RF front-end pins

Table 10. RF front-end pins

Symbol	I/O Voltage	I/O	Functions	TFBGA169
LNA_IN	VRF12_LNA	I	Low noise amplifier input	K1
LNA_OUT	VRF12_LNA	O	Low noise amplifier output	M1
RFA_IN	VRF12_RFA	I	RF amplifier input	N4
XTAL_In	VRF12_RFDig	I	Input side of crystal oscillator or TCXO input	N6
XTAL_Out	VRF12_RFDig	O	Output side of crystal oscillator	M6

3 Package and packing information

3.1 ECOPACK[®] packages

In order to meet environmental requirements, ST offers these devices in different grades of ECOPACK[®] packages, depending on their level of environmental compliance. ECOPACK[®] specifications, grade definitions and product status are available at: www.st.com.

ECOPACK[®] is an ST trademark.

3.2 TFBGA169 9 x 9 x 1.2 mm package information

Table 11. TFBGA169 9 x 9 x 1.2 mm mechanical data

Ref. dim	Data book (mm)			Drawing (mm)		
	Min.	Typ.	Max.	Min.	Typ.	Max.
A ⁽¹⁾			1.20			1.07
A1 ⁽²⁾	0.21			0.22	0.27	0.32
A2		0.20		0.16	0.20	0.24
A4		0.585		0.57	0.585	0.60
b ⁽³⁾	0.30	0.35	0.40	0.30	0.35	0.40
D	8.85	9.00	9.15	8.90	9.00	9.10
D1		7.80			7.80	
E	9.85	9.00	9.15	8.90	9.00	9.10
E1		7.80			7.80	
e		0.65			0.65	
Z		0.60			0.60	
ddd			0.08			0.08
eee ⁽⁴⁾			0.15			0.15
fff ⁽⁵⁾			0.05			0.05

- TFBGA stands for Thin profile Fine Pitch Ball Grid Array.
 - The total profile height (Dim A) is measured from the seating plane to the top of the component
 - The maximum total package height is calculated by the following methodology:
 $A \text{ Max} = A1 \text{ Typ} + A2 \text{ Typ} + A4 \text{ Typ} + \sqrt{A1^2 + A2^2 + A4^2}$ tolerance values
 - Thin profile: $1.00 \text{ mm} < A \leq 1.20 \text{ mm}$ / Fine pitch: $e < 1.00 \text{ mm}$ pitch.
- The terminal A1 corner must be identified on the top surface by using a corner chamfer, ink or metallized markings, or other feature of package body or integral heatslug.
 - A distinguishing feature is allowable on the bottom surface of the package to identify the terminal A1 corner. Exact shape of each corner is optional.
- The typical ball diameter before mounting is 0.35 mm.
- The tolerance of position that controls the location of the pattern of balls with respect to datums A and B. For each ball there is a cylindrical tolerance zone eee perpendicular to datum C and located on true position with respect to datums A and B as defined by e. The axis perpendicular to datum C of each ball must lie within this tolerance zone.

- The tolerance of position that controls the location of the balls within the matrix with respect to each other. For each ball there is a cylindrical tolerance zone ϕff perpendicular to datum C and located on true position as defined by e . The axis perpendicular to datum C of each ball must lie within this tolerance zone. Each tolerance zone ϕff in the array is contained entirely in the respective zone ϕee above. The axis of each ball must lie simultaneously in both tolerance zones.

Figure 2. TFBGA169 9 x 9 x 1.2 mm package dimension

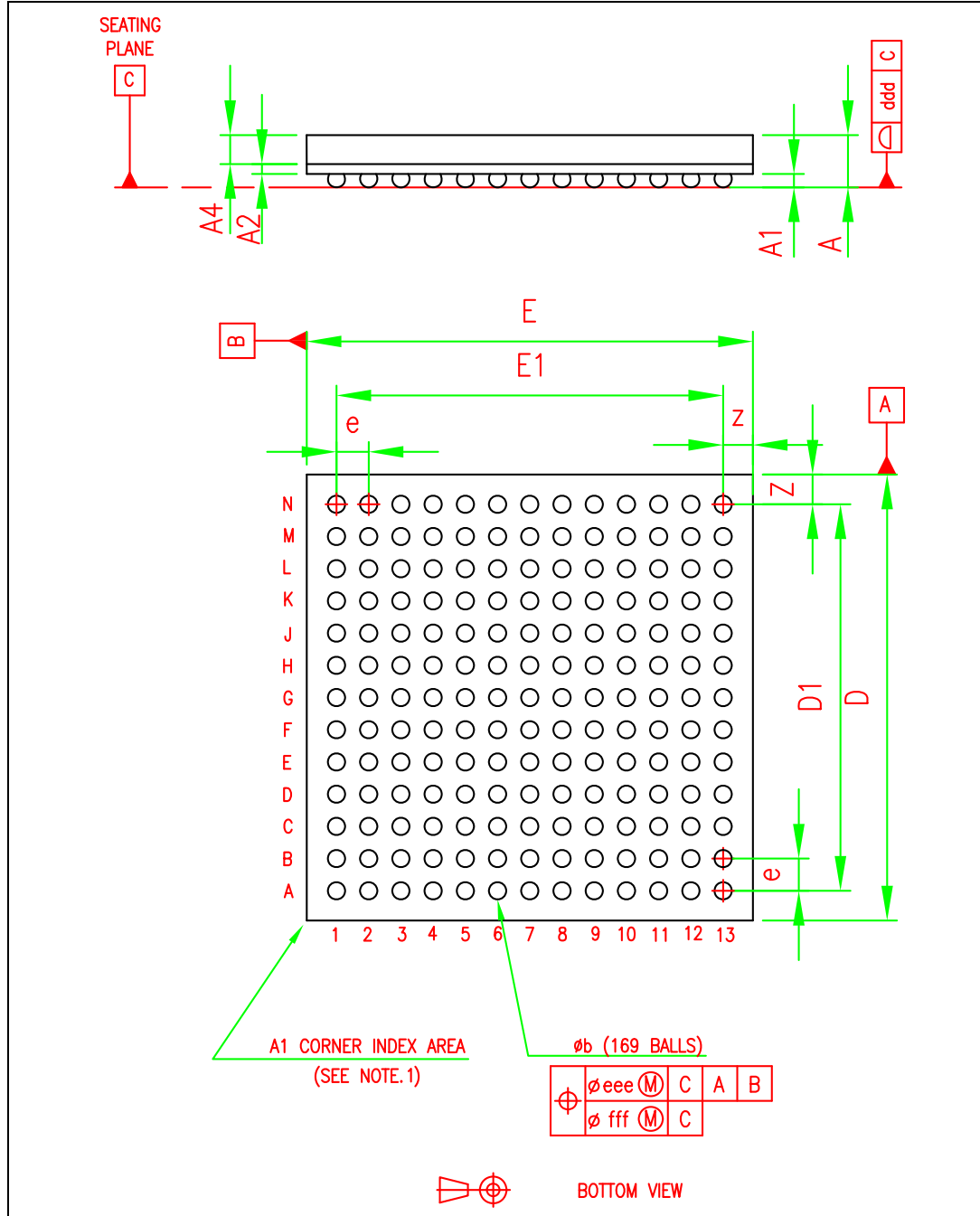

- The terminal A1 corner must be identified on the top surface by using a corner chamfer, ink or metallized markings, or other feature of package body or integral heatslug.
 - A distinguishing feature is allowable on the bottom surface of the package to identify the terminal A1 corner. Exact shape of each corner is optional.

3.3 TFBGA169 12 x 12 x 1.2 mm package information

Table 12. TFBGA169 12 x 12 x 1.2 mm mechanical data

Ref. dim	Data book (mm)			Drawing (mm)		
	Min.	Typ.	Max.	Min.	Typ.	Max.
A ⁽¹⁾			1.20			1.15
A1 ⁽²⁾	0.21			0.25	0.30	0.35
A2		0.20		0.16	0.20	0.24
A4			0.60	0.57	0.585	0.60
b ⁽³⁾	0.35	0.40	0.45	0.35	0.40	0.45
D	11.85	12.00	11.85	11.90	12.00	12.10
D1		9.60			9.60	
E	11.85	12.00	11.85	11.90	12.00	12.10
E1		9.60			9.60	
e		0.80			0.80	
Z		1.20			1.20	
ddd			0.10			0.10
eee ⁽⁴⁾			0.15			0.15
fff ⁽⁵⁾			0.08			0.08

- TFBGA stands for Thin Profile Fine Pitch Ball Grid Array.
 - Thin profile: 1.00mm < A . 1.20mm / Fine pitch: e < 1.00mm.
 - The total profile height (Dim A) is measured from the seating plane gCh to the top of the component.
 - The maximum total package height is calculated by the RSS method (Root Sum Square):
 $A_{Max} = A1_{Typ} + A2_{Typ} + A4_{Typ} + \tilde{a} (A12 + A22 + A42 \text{ tolerance values})$.
- The terminal A1 corner must be identified on the top surface by using a corner chamfer, ink or metallized markings, or other feature of package body or integral heat slug.
 - A distinguishing feature is allowable on the bottom surface of the package to identify the terminal A1 corner. Exact shape of each corner is optional.
- The typical ball diameter before mounting is 0.40 mm.
- The tolerance of position that controls the location of the pattern of balls with respect to datums A and B. For each ball there is a cylindrical tolerance zone eee perpendicular to datum C and located on true position with respect to datums A and B as defined by e. The axis perpendicular to datum C of each ball must lie within this tolerance zone.
- The tolerance of position that controls the location of the balls within the matrix with respect to each other. For each ball there is a cylindrical tolerance zone fff perpendicular to datum C and located on true position as defined by e. The axis perpendicular to datum C of each ball must lie within this tolerance zone. Each tolerance zone fff in the array is contained entirely in the respective zone eee above The axis of each ball must lie simultaneously in both tolerance zones.

Figure 3. TFBGA169 12 x 12 x 1.2 mm package dimension

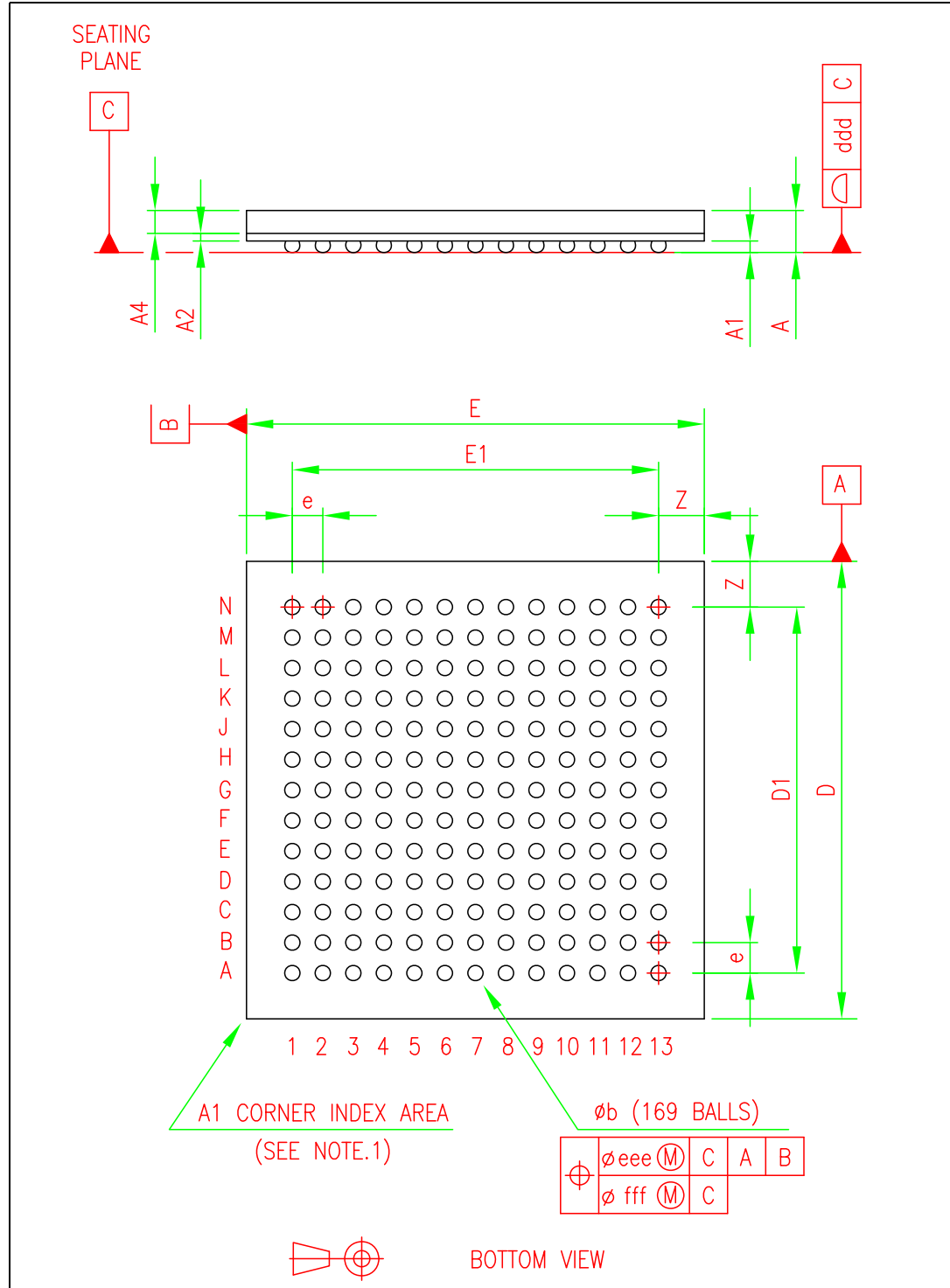

- The terminal A1 corner must be identified on the top surface by using a corner chamfer, ink or metallized markings, or other feature of package body or integral heat slug.
 - A distinguishing feature is allowable on the bottom surface of the package to identify the terminal A1 corner. Exact shape of each corner is optional.

4 Ordering information

Figure 4. Ordering information scheme

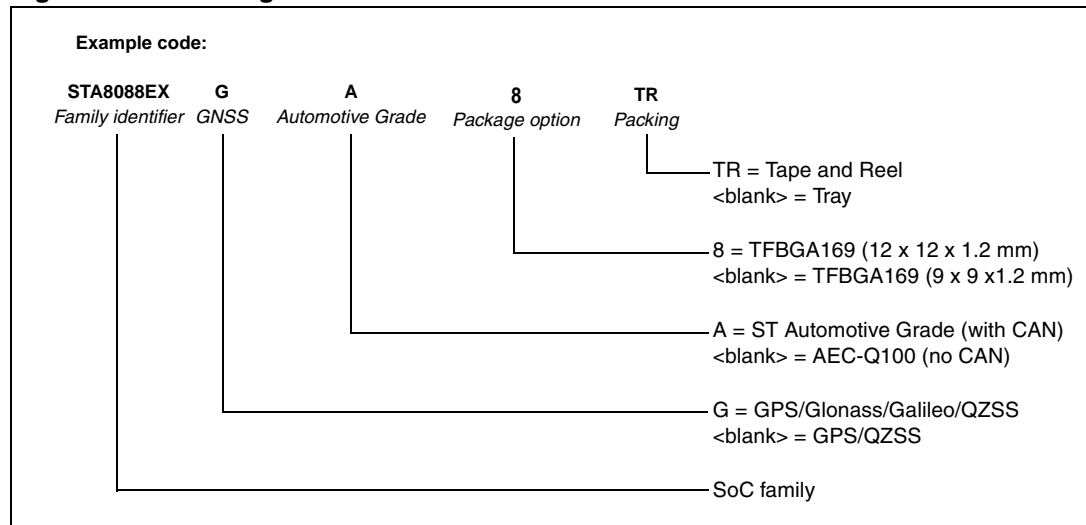

5 Revision history

Table 13. Document revision history

Date	Revision	Changes
23-Jan-2012	1	Initial release.
26-Mar-2012	2	Updated <i>Features</i> list <i>Table 4: Main function pins:</i> – USB_DP/UART1_TX, USB_DM/UART1_RX: updated I/O Added <i>Section 3.3: TFBGA169 12 x 12 x 1.2 mm package information</i> Updated <i>Figure 4: Ordering information scheme</i>

Please Read Carefully:

Information in this document is provided solely in connection with ST products. STMicroelectronics NV and its subsidiaries ("ST") reserve the right to make changes, corrections, modifications or improvements, to this document, and the products and services described herein at any time, without notice.

All ST products are sold pursuant to ST's terms and conditions of sale.

Purchasers are solely responsible for the choice, selection and use of the ST products and services described herein, and ST assumes no liability whatsoever relating to the choice, selection or use of the ST products and services described herein.

No license, express or implied, by estoppel or otherwise, to any intellectual property rights is granted under this document. If any part of this document refers to any third party products or services it shall not be deemed a license grant by ST for the use of such third party products or services, or any intellectual property contained therein or considered as a warranty covering the use in any manner whatsoever of such third party products or services or any intellectual property contained therein.

UNLESS OTHERWISE SET FORTH IN ST'S TERMS AND CONDITIONS OF SALE ST DISCLAIMS ANY EXPRESS OR IMPLIED WARRANTY WITH RESPECT TO THE USE AND/OR SALE OF ST PRODUCTS INCLUDING WITHOUT LIMITATION IMPLIED WARRANTIES OF MERCHANTABILITY, FITNESS FOR A PARTICULAR PURPOSE (AND THEIR EQUIVALENTS UNDER THE LAWS OF ANY JURISDICTION), OR INFRINGEMENT OF ANY PATENT, COPYRIGHT OR OTHER INTELLECTUAL PROPERTY RIGHT.

UNLESS EXPRESSLY APPROVED IN WRITING BY TWO AUTHORIZED ST REPRESENTATIVES, ST PRODUCTS ARE NOT RECOMMENDED, AUTHORIZED OR WARRANTED FOR USE IN MILITARY, AIR CRAFT, SPACE, LIFE SAVING, OR LIFE SUSTAINING APPLICATIONS, NOR IN PRODUCTS OR SYSTEMS WHERE FAILURE OR MALFUNCTION MAY RESULT IN PERSONAL INJURY, DEATH, OR SEVERE PROPERTY OR ENVIRONMENTAL DAMAGE. ST PRODUCTS WHICH ARE NOT SPECIFIED AS "AUTOMOTIVE GRADE" MAY ONLY BE USED IN AUTOMOTIVE APPLICATIONS AT USER'S OWN RISK.

Resale of ST products with provisions different from the statements and/or technical features set forth in this document shall immediately void any warranty granted by ST for the ST product or service described herein and shall not create or extend in any manner whatsoever, any liability of ST.

ST and the ST logo are trademarks or registered trademarks of ST in various countries.

Information in this document supersedes and replaces all information previously supplied.

The ST logo is a registered trademark of STMicroelectronics. All other names are the property of their respective owners.

© 2012 STMicroelectronics - All rights reserved

STMicroelectronics group of companies

Australia - Belgium - Brazil - Canada - China - Czech Republic - Finland - France - Germany - Hong Kong - India - Israel - Italy - Japan - Malaysia - Malta - Morocco - Philippines - Singapore - Spain - Sweden - Switzerland - United Kingdom - United States of America

www.st.com