

4 x 13 W dual/quad power amplifier

Features

- High output power capability
 - 2x 38 W into 4 Ω at 18 V, 1 kHz, 10%THD
 - 2x 34 W into 8 Ω at 22 V, 1 kHz, 10%THD
 - 2x 24 W into 4 Ω at 14.4 V, 1 kHz, 10%THD
 - 2x 15 W into 8 Ω at 16 V, 1 kHz, 10%THD
 - 4x 13 W into 2 Ω at 15 V, 1 kHz, 10%THD
 - 4x 11 W into 4 Ω at 18 V, 1 kHz, 10%THD
 - 4x 7 W into 4 Ω at 14.4 V, 1 kHz, 10%THD
- Minimum external components count:
 - no bootstrap capacitors
 - no Boucherot cells
 - internally fixed gain 20 dB
- Standby function (CMOS compatible)
- No audible pop during standby operations
- Diagnostic facilities:
 - clip detector
 - output to GND short-circuit detector
 - output to VS short-circuit detector
 - soft short-circuit check at turn-on
 - thermal shutdown warning

Protection

- Output AC/DC short circuit
- Soft short-circuit check at turn-on
- Thermal cutoff/limiter to prevent chip from overheating
- High inductive loads
- ESD

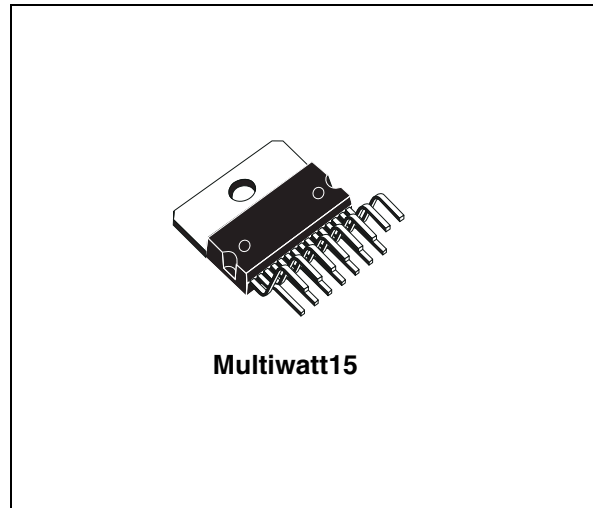

Description

The STA540 is a 4-channel, class AB audio amplifier designed for high quality sound applications.

The amplifiers have single-ended outputs with integrated short-circuit protection, thermal protection and diagnostic functions.

The chip is housed in the 15-pin Multiwatt ECOPACK[®] Pb-free package which is RoHS (2002/95/EC) compliant.

Table 1. Device summary

Order code	Temperature range	Package	Packing
STA540	-40 to 150° C	Multiwatt15	Tube

Contents

- 1 Block diagram and pin description 4**
 - 1.1 Block diagram 4
 - 1.2 Pin description 5

- 2 Electrical specifications 6**
 - 2.1 Absolute maximum ratings 6
 - 2.2 Thermal data 6
 - 2.3 Electrical characteristics 6

- 3 Standard application circuits 8**

- 4 Electrical characteristics curves 10**

- 5 Thermal information 13**
 - 5.1 Heatsink specification examples 13
 - 5.1.1 R_{th_HS} calculation for 4 single-ended channels 13
 - 5.1.2 R_{th_HS} calculation for 2 single-ended channels plus 1 BTL channel ... 13
 - 5.1.3 Calculations using music power 14

- 6 Practical information 15**
 - 6.1 Highly flexible amplifier configuration 15
 - 6.2 Easy single-ended to bridge transition 15
 - 6.3 Internally fixed gain 15
 - 6.4 Silent turn on/off and muting/standby function 15
 - 6.5 Driving circuit for standby mode 15
 - 6.6 Output stage 16
 - 6.6.1 Rail-to-rail output voltage swing without bootstrap capacitors 16
 - 6.6.2 Absolute stability without external compensation 16
 - 6.7 Built-in protection 17
 - 6.7.1 Diagnostic facilities (pin 10) 17
 - 6.7.2 Short-circuit protection 17
 - 6.7.3 Clipping detection 18
 - 6.7.4 Thermal shutdown 18

6.8	Handling the diagnostic information	19
6.9	PCB ground layout	20
6.10	Mute function	20
7	Package information	21
8	Revision history	22

1 Block diagram and pin description

1.1 Block diagram

Figure 1. Block diagram

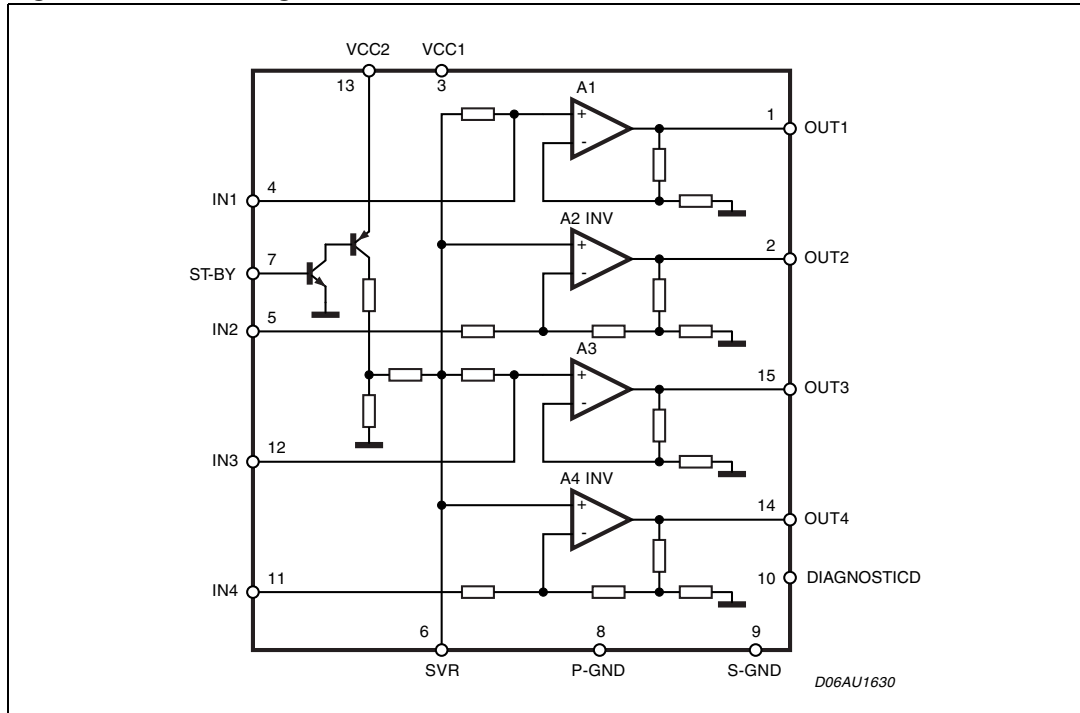

1.2 Pin description

Figure 2. Pin connection (top view)

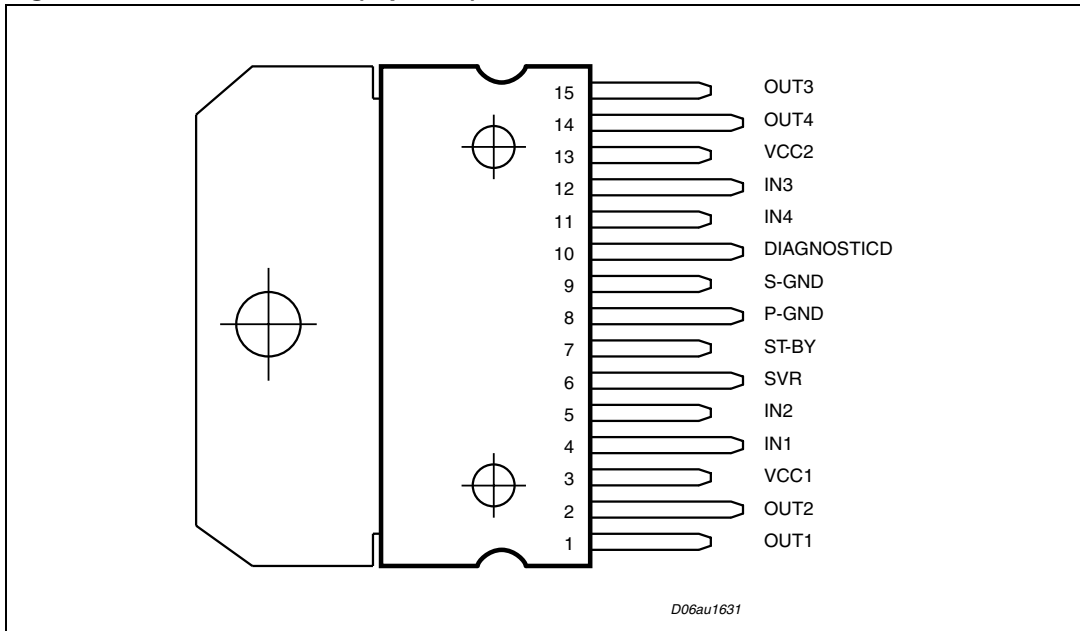

Table 2. Pin description

N°	Name	Type	Function
1	OUT1	OUT	Channel 1 output
2	OUT2	OUT	Channel 2 output
3	VCC1	PWR	Power supply
4	IN1	IN	Channel 1 input
5	IN2	IN	Channel 2 input
6	SVR	IN	Supply voltage rejection
7	ST-BY	IN	Standby control pin
8	P-GND	PWR	Power ground
9	S-GND	PWR	Signal ground
10	DIAGNOSTICD	OUT	Diagnostics output
11	IN4	IN	Channel 4 input
12	IN3	IN	Channel 3 input
13	VCC2	PWR	Power supply
14	OUT4	OUT	Channel 4 output
15	OUT3	OUT	Channel 3 output

2 Electrical specifications

2.1 Absolute maximum ratings

Table 3. Absolute maximum ratings

Symbol	Parameter	Value	Unit
V_S	Supply voltage idle mode (no signal)	24	V
	Supply voltage operating	22	V
	Supply voltage AC-DC short safe	20	V
P_{tot}	Total power dissipation ($T_{case} = 85\text{ °C}$)	36	W
T_{stg}, T_j	Storage and junction temperature	-40 to 150	°C
T_{op}	Operating temperature	0 to 70	°C

2.2 Thermal data

Table 4. Thermal data

Symbol	Parameter	Value	Unit
$R_{th\ j-case}$	Thermal resistance junction to case (max)	1.8	°C/W
$R_{th\ j-amb}$	Thermal resistance junction to ambient (max)	35	°C/W

2.3 Electrical characteristics

The test conditions are $V_S = 14.4\text{ V}$, $R_L = 4\ \Omega$, $f = 1\text{ kHz}$, $T_{amb} = 25\text{ °C}$ unless otherwise specified.

Table 5. Electrical characteristics

Symbol	Parameter	Test condition	Min	Typ	Max	Unit
V_S	Supply voltage range		8		22	V
I_d	Total quiescent drain current			80	150	mA
V_{os}	Output offset voltage		-150		150	mV
P_o	Output power, SE	THD=10%, $R_L=4\ \Omega$ THD=10%, $R_L=2\ \Omega$ THD=10%, $R_L=4\ \Omega$, $V_S=22\text{ V}$	6.5	7 11.5 16		W
	Output power, BTL	THD=10%, $R_L=4\ \Omega$ THD=10%, $R_L=8\ \Omega$, $V_S=17\text{ V}$ THD=10%, $R_L=8\ \Omega$, $V_S=22\text{ V}$	21	24 20 34		W
THD	Total harmonic distortion	$R_L = 4\ \Omega$, $P_o = 0.1\text{ to }4\text{ W}$		0.02		%
I_{SC}	Short-circuit output current		4.0			A

Table 5. Electrical characteristics (continued)

Symbol	Parameter	Test condition	Min	Typ	Max	Unit
C_T	Crosstalk	f = 1 kHz single-ended f = 10 kHz single-ended f = 1 kHz BTL f = 10 kHz BTL	55	70 60 60		dB
R_{in}	Input impedance	Single-ended BTL	20 10	30 15		k Ω
G_V	Voltage gain	Single-ended BTL	19 25	20 26	21 27	dB
G_V	Voltage gain match				0.5	dB
E_N	Input noise voltage	$R_{gen} = 0$, "A" weighted, S.E.: Non-inverting channels		2		μ V
		Inverting channels		5		μ V
		BTL $R_{gen} = 0$, f = 22 Hz to 22 kHz		3.5		μ V
SVR	Supply voltage rejection	$R_{gen} = 0$, f = 300 Hz, $C_{SVR} = 470 \mu$ F	50			dB
A_{SB}	Standby attenuation	$P_o = 1$ W	80	90		dB
I_{SB}	Current consumption in standby	$V_{ST_BY} = 0$ to 1.5 V			100	μ A
V_{ST_BY}	Pin ST-BY voltage for play				1.5	V
	Pin ST-BY voltage for standby		3.5			V
I_{ST_BY}	Pin ST-BY current	Play mode, $V_{ST_BY} = 5$ V			50	μ A
		Max driving current under fault			5	mA
I_{cd_off}	Clipping detector output average current	d = 1% (*)		90		μ A
I_{cd_on}	Clipping detector output average current	d = 5% (*)		160		μ A
V_{DIAGNO} V_{STICD}	Saturation voltage on pin DIAGNOSTICD	$I_{DIAGNOSTICD} = 1$ mA sinking			0.7	V
T_W	Thermal warning			140		$^{\circ}$ C
T_M	Thermal muting			150		$^{\circ}$ C
T_S	Thermal shutdown			160		$^{\circ}$ C

3 Standard application circuits

Figure 3. Quadraphonic

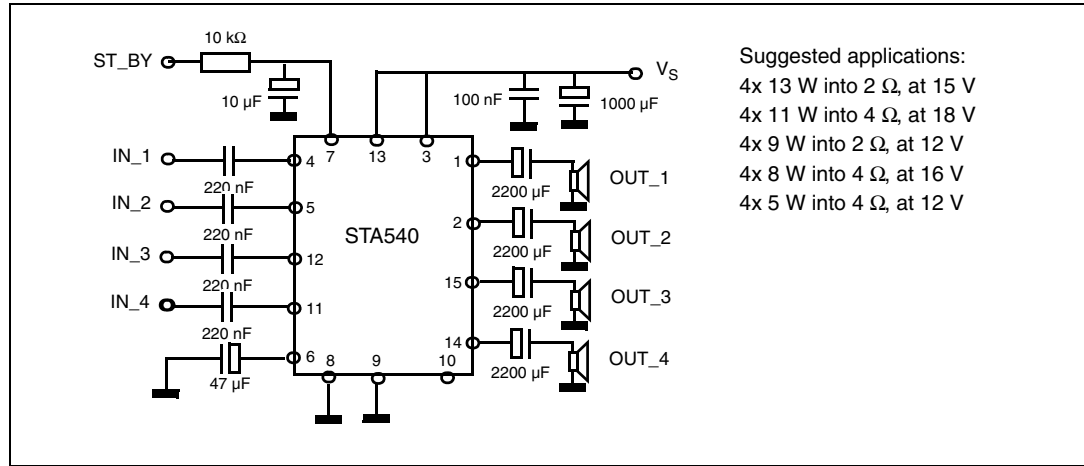

Figure 4. Alternative single-ended speaker connection

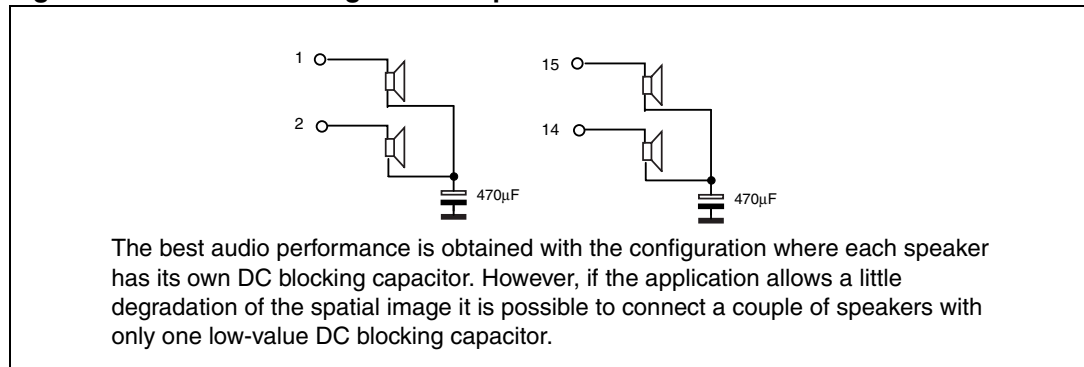

Figure 5. Dual bridge

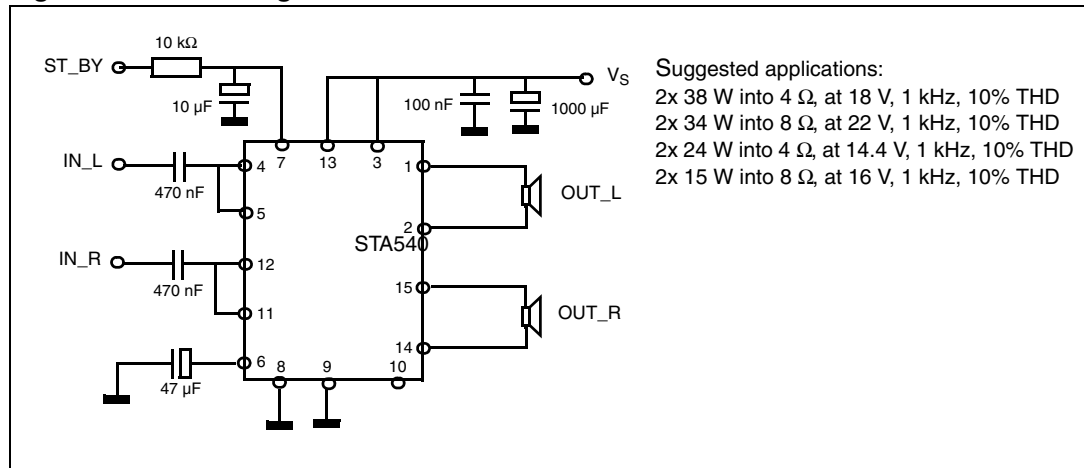
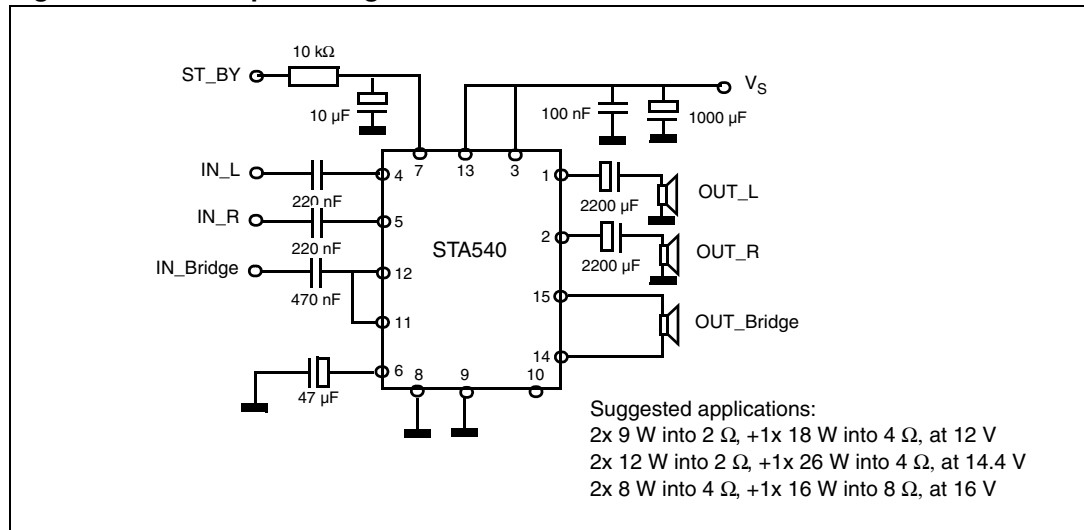

Figure 6. Stereo plus bridge drive



4 Electrical characteristics curves

Figure 7. Quiescent drain current versus supply voltage (single-ended and bridge)

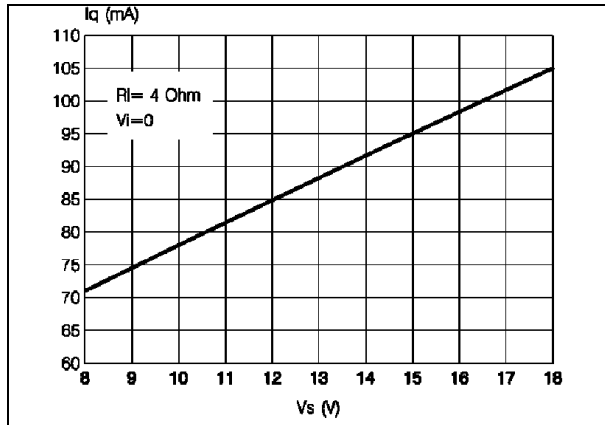

Figure 8. Quiescent output voltage versus supply voltage (single-ended and bridge)

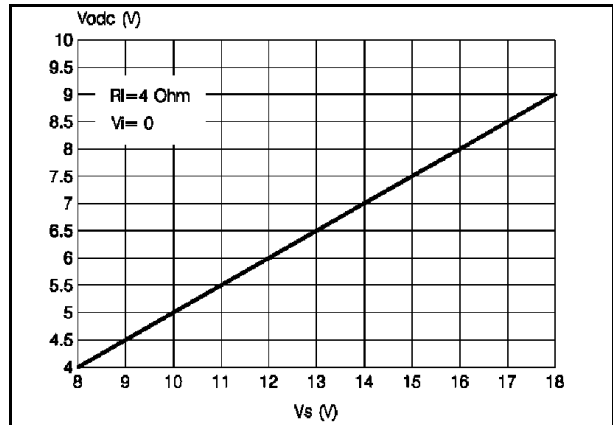

Figure 9. Output power versus supply voltage Figure 10. Output power versus supply voltage

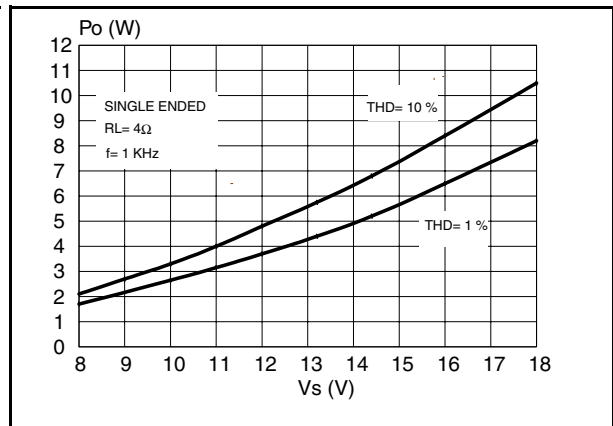
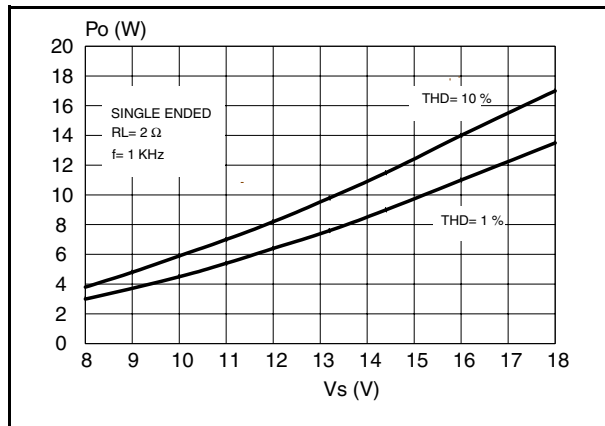

Figure 11. Output power versus supply voltage Figure 12. Distortion versus output power

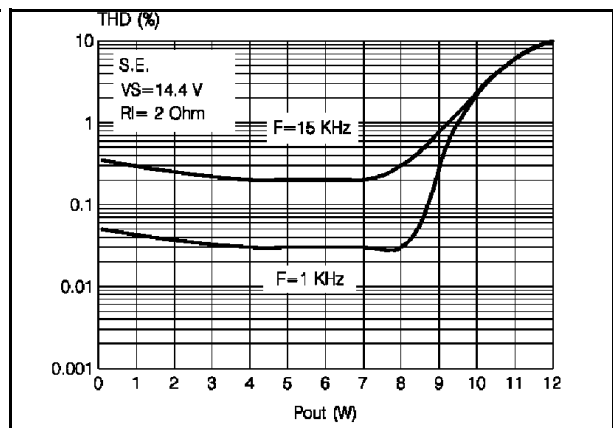
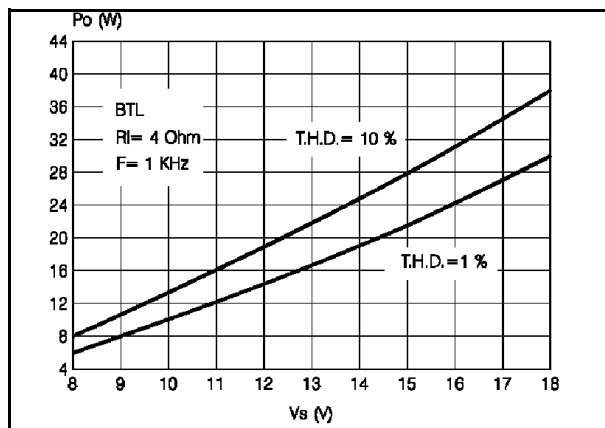

Figure 13. Distortion versus output power

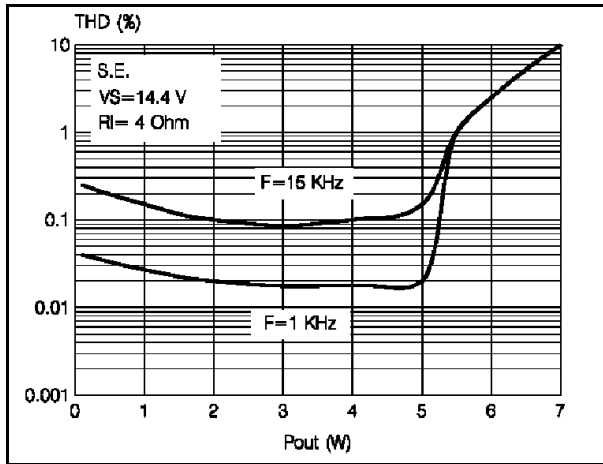

Figure 14. Distortion versus output power

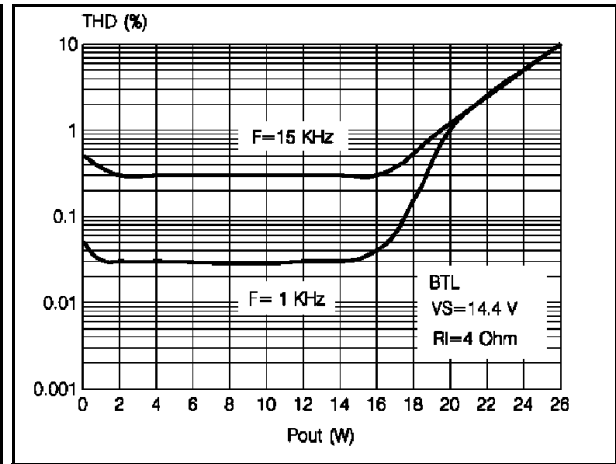

Figure 15. Output power versus supply voltage

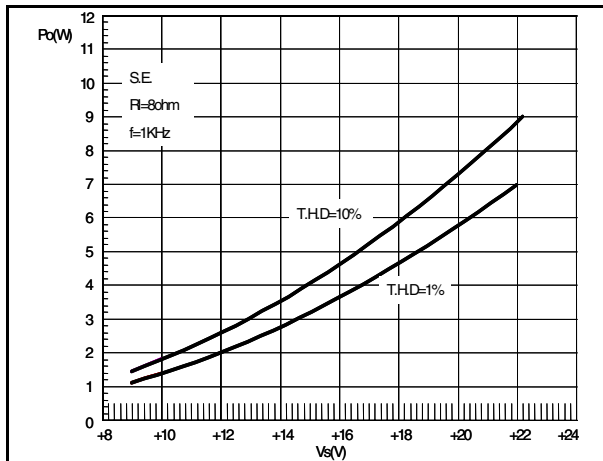

Figure 16. Output power versus supply voltage

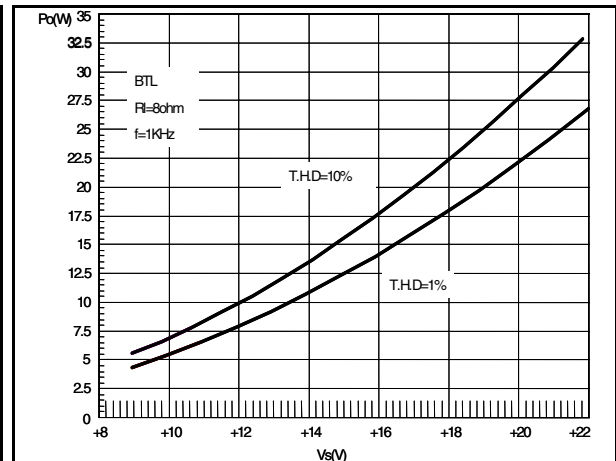

Figure 17. Supply voltage rejection versus frequency

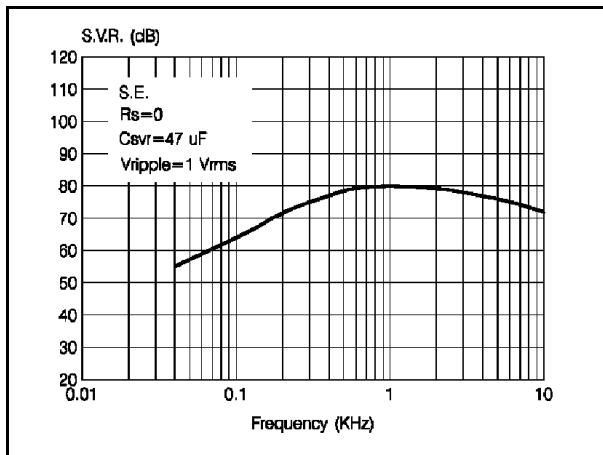

Figure 18. Crosstalk versus frequency

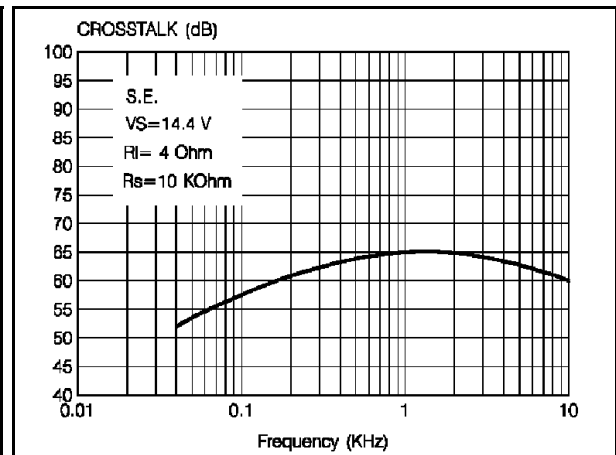

Figure 19. Standby attenuation versus threshold voltage

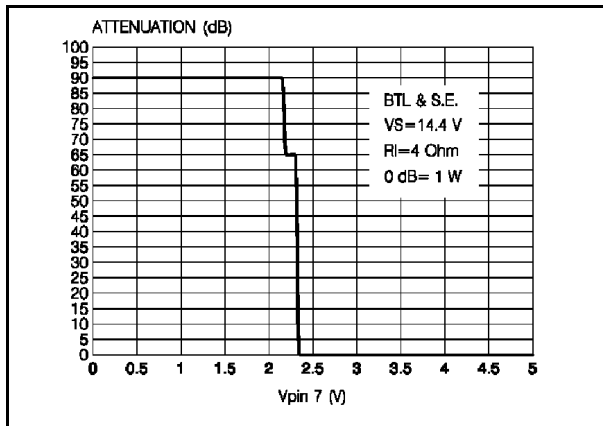

Figure 20. Total power dissipation and efficiency versus output power

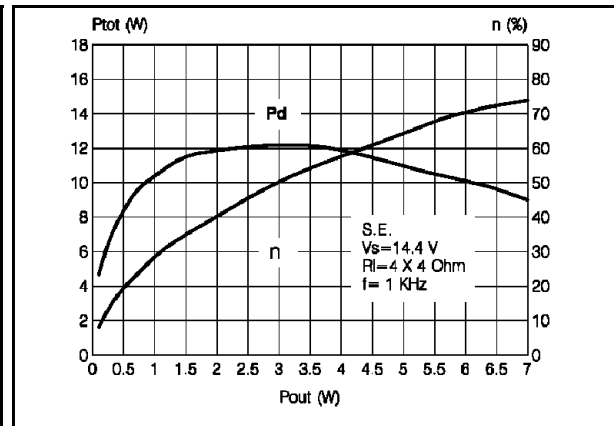
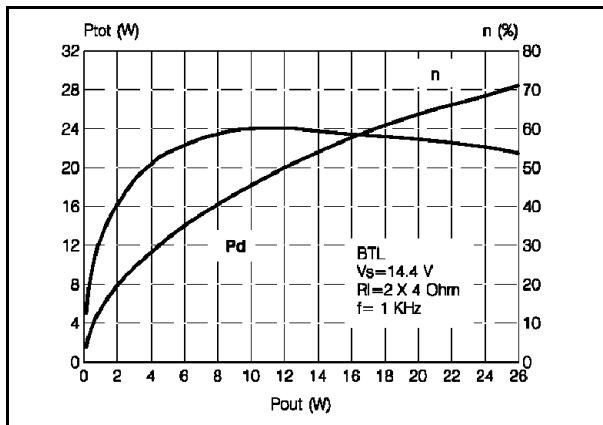

Figure 21. Total power dissipation and efficiency versus output power



5 Thermal information

In order to avoid the intervention of the thermal protection, placed at $T_j=150^\circ\text{C}$ for thermal muting and $T_j=160^\circ\text{C}$ for thermal shutdown, it is important to calculate the heatsink thermal resistance, R_{th_HS} , correctly.

The parameters that influence the calculation are:

- maximum dissipated power for the device (P_{dmax})
- maximum thermal resistance junction to case (R_{th_j-case})
- maximum ambient temperature T_{amb_max}

There is also an additional term that depends on the I_q (quiescent current).

5.1 Heatsink specification examples

5.1.1 R_{th_HS} calculation for 4 single-ended channels

Given $V_S = 14.4\text{ V}$, $R_L = 4\ \Omega \times 4$ channels, $R_{th_j-case} = 1.8^\circ\text{C/W}$, $T_{amb_max} = 50^\circ\text{C}$ and $P_{out} = 4 \times 7\text{ W}$ then

the maximum power dissipated in the device is:

$$P_{dmax} = N_{Channel} \cdot \frac{V_{CC}^2}{2\Pi^2 R_L} = 4 \cdot 2.62 = 10.5\text{W}$$

and the required thermal resistance of the heatsink is:

$$R_{th_HS} = \frac{150 - T_{amb_max}}{P_{dmax}} - R_{th_j-case} = \frac{150 - 50}{10.5} - 1.8 = 7.7^\circ\text{C/W}$$

5.1.2 R_{th_HS} calculation for 2 single-ended channels plus 1 BTL channel

Given $V_S = 14.4\text{ V}$, $R_L = 2 \times 2\ \Omega$ (SE) + $1 \times 4\ \Omega$ (BTL), $P_{out} = 2 \times 12\text{ W} + 1 \times 26\text{ W}$ then

the maximum power dissipated in the device is:

$$P_{dmax} = 2 \cdot \frac{V_{CC}^2}{2\Pi^2 R_L} + \frac{2V_{CC}^2}{\Pi^2 R_L} = 2 \cdot 5.25 + 10.5 = 21\text{W}$$

and the required thermal resistance of the heatsink is:

$$R_{th_HS} = \frac{150 - T_{amb_max}}{P_{dmax}} - R_{th_j-case} = \frac{150 - 50}{21} - 1.8 = 3^\circ\text{C/W}$$

5.1.3 Calculations using music power

The thermal resistance value calculated in each of the two above examples specifies a heatsink capable of sustaining the maximum dissipated power. Realistically, however, and as explained in the Application Note (AN1965), the heatsink can be smaller when the application is musical content.

When music power is considered the resulting dissipation is about 40% less than the calculated maximum. Thus, smaller or cheaper heatsinks can be employed. The heatsink thermal resistance values are modified as follows:

for example [5.1.1](#): $10.5 \text{ W} - 40\% = 6.3 \text{ W}$, thus giving $R_{\text{th_c-amb}} = 14^\circ \text{ C/W}$,

for example [5.1.2](#): $21 \text{ W} - 40\% = 12.6 \text{ W}$, thus giving $R_{\text{th_c-amb}} = 6^\circ \text{ C/W}$.

6 Practical information

6.1 Highly flexible amplifier configuration

The availability of four independent channels makes it possible to accomplish several kinds of applications ranging from four speakers stereo (F/R) to two-speaker bridge solutions.

When working with single-ended configurations, the polarity of the speakers driven by the inverting amplifier must be reversed with respect to those driven by non-inverting channels. This is to avoid phase irregularities causing sound alterations especially during the reproduction of low frequencies.

6.2 Easy single-ended to bridge transition

The change from single-ended to bridge configuration is made simple by connecting the two inputs together and also the speaker directly between the two outputs (no need for additional external components, in fact the output DC blocking capacitors are eliminated). However, take care to use an inverting/non-inverting amplifier pair.

6.3 Internally fixed gain

The advantages in internally fixing the gain (to 20 dB in single-ended configuration and to 26 dB in bridge configuration) are:

- components and space saving,
- output noise, supply voltage rejection and distortion optimization.

6.4 Silent turn on/off and muting/standby function

The standby mode can be easily activated by means of a CMOS logic level applied to pin ST-BY through a RC filter.

Under standby conditions, the device is turned off completely (supply current = 1 mA typical, output attenuation = 80 dB minimum).

All on/off operations are virtually pop-free. Furthermore, at turn-on the device stays in mute condition for a time determined by the value of the SVR capacitor. This prevents transients, coming from previous stages, from producing unpleasant acoustic effects at the speakers.

6.5 Driving circuit for standby mode

Some precautions need to be taken when designing the driving circuit for pin 7, ST-BY. For instance, the pin cannot be directly driven by a voltage source having a current capability higher than 5 mA. In practical cases a series resistance must be inserted, giving it the double purpose of limiting the current at pin 7 and to smooth down the standby on/off transitions. And, when done in combination with a capacitor, prevents output pop.

A capacitor of at least 100 nF from pin 7 to S-GND, with no resistance in between, is necessary to ensure correct turn-on.

6.6 Output stage

The fully complementary output stage is possible with the power ICV PNP component.

This novel design is based on the connection shown in *Figure 22* and allows the full exploitation of its capabilities. The clear advantages this new approach has over classical output stages are described in the following sections.

6.6.1 Rail-to-rail output voltage swing without bootstrap capacitors

The output swing is limited only by the V_{CEsat} of the output transistors, which are in the range of 0.3Ω (R_{sat}) each.

Classical solutions adopting composite PNP-NPN for the upper output stage have higher saturation loss on the top side of the waveform.

This unbalanced saturation causes a significant power reduction. The only way to recover power includes of the addition of expensive bootstrap capacitors.

6.6.2 Absolute stability without external compensation

With reference to the circuit shown in *Figure 22*, the low frequency gain V_{out}/V_{in} is greater than unity, that is, approximately $1 + R2/R1$. The DC output level ($VCC / 2$) is fixed by an auxiliary amplifier common to all the channels.

By controlling the amount of this local feedback it is possible to force the loop gain ($A \cdot \beta$) to less than unity at frequency where the phase shift is 180° . This means that the output buffer is intrinsically stable and not prone to oscillation.

The above feature has been achieved even though there is very low closed-loop gain of the amplifier.

This contrasts with the classical PNP-NPN stage which makes use of external RC networks, namely the Boucherot cells, for reducing the gain at high frequencies.

Figure 22. The new output stage

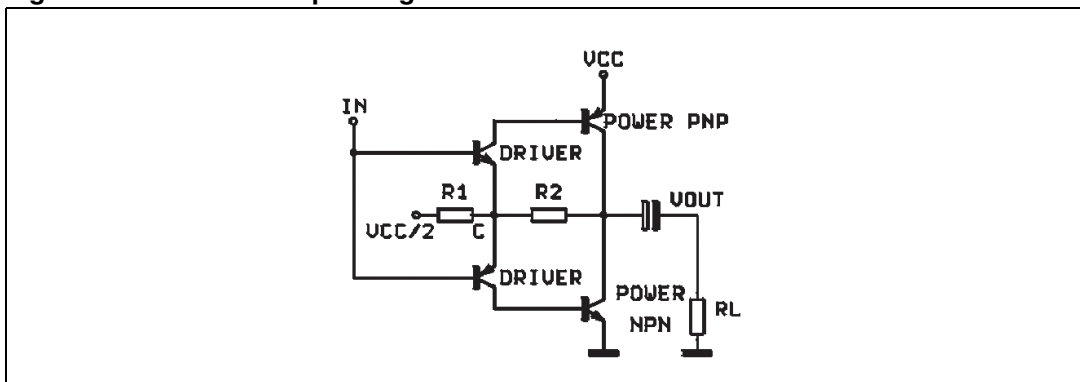

6.7 Built-in protection

6.7.1 Diagnostic facilities (pin 10)

The STA540 is equipped with diagnostic circuitry that is able to detect the following events:

- clipping of the output signal,
- thermal shutdown,
- output fault:
 - short circuit to GND,
 - short circuit to VS,
 - soft short circuit at turn-on.

The event is signalled when the open collector output of pin 10 begins to sink current.

6.7.2 Short-circuit protection

Reliable and safe operation in the presence of all kinds of output short circuit is assured by the built-in protection. As well as the AC/DC short circuit to GND and to VS, and across the speaker, there is a soft short-circuit condition, which is signalled on pin 10 (DIAGNOSTICD) during the turn-on phase, to verify output circuit integrity in order to ensure correct amplifier operation.

This particular kind of protection acts in such a way as to prevent the device being turned on (via pin ST-BY) when a resistive path (that is a DC path) less than 16 Ω exists between the output and GND. This would avoid loud speaker damage should, for example, the output coupling capacitor develop an internal short circuit.

As mentioned previously, it is important to limit the external current driving pin ST-BY to 5 mA. The reason is that the associated circuitry is normally disabled with currents greater than 5 mA.

The soft short-circuit protection is particularly attractive when, in the single-ended configuration, one capacitor is shared between two outputs (see [Figure 23](#)).

Figure 23. Shared capacitor in single-ended configuration

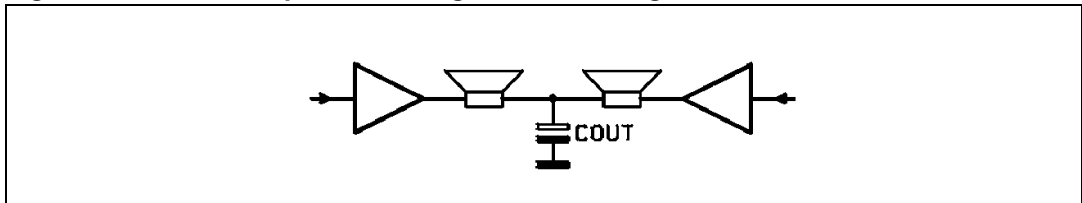

6.7.3 Clipping detection

Figure 24. Clipping detection waveforms

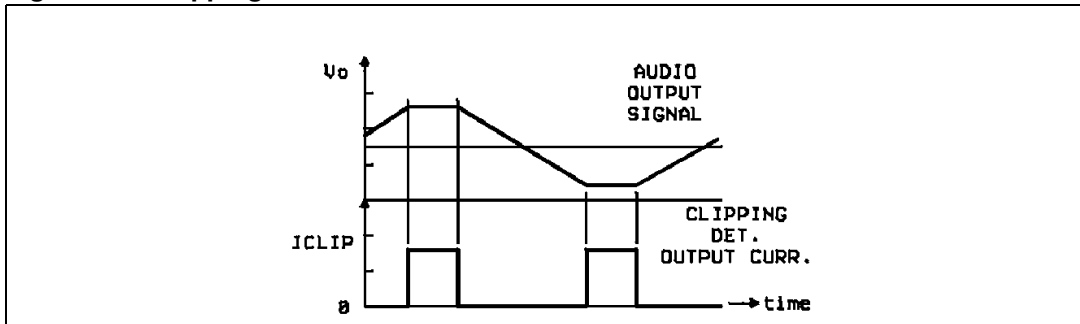

Current sinking at pin 10 occurs when a certain distortion level is reached at each output. This function initiates a gain-compression facility whenever the amplifier is overdriven.

6.7.4 Thermal shutdown

With the thermal shutdown feature, the diagnostics output (pin 10) signals the closeness of the junction temperature to the shutdown threshold. Typically, current sinking at pin 10 starts approximately 10° C before the shutdown temperature is reached.

Figure 25. Output fault waveforms (see Figure 26)

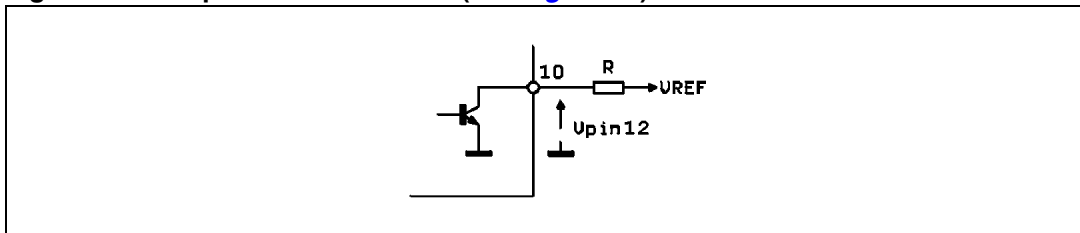
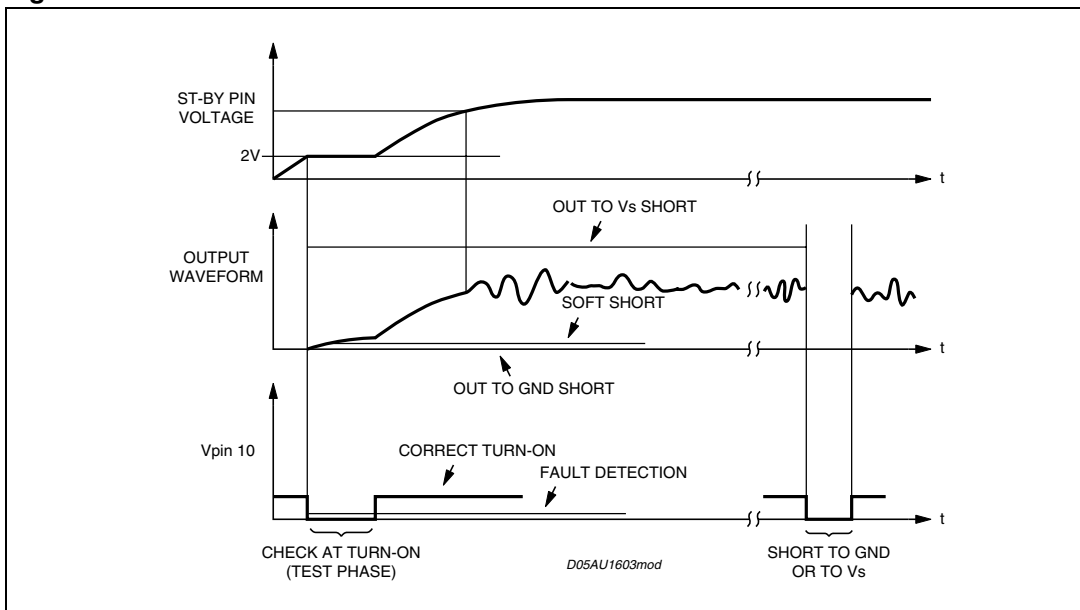

Figure 26. Fault waveforms



6.8 Handling the diagnostic information

As different diagnostic information (clipping detection, output fault, approaching thermal shutdown) becomes available at pin 10 so the behavior of the signal at this pin changes.

In order to discriminate the event, signal DIAGNOSTICD, pin 10, must be interpreted correctly. *Figure 27* shows a combination of events on the output waveform and the corresponding output on pin 10.

This events could be diagnosed based on the timing of the output signal on pin 10. For example, the clip-detector signalling under fault conditions could produce a low level for a short time. On the other hand, an output short circuit would probably produce a low level for a much longer time. With these assumptions, an interface circuit based on the one shown in *Figure 28* could differentiate the information and flag the appropriate circuits.

Figure 27. Waveforms

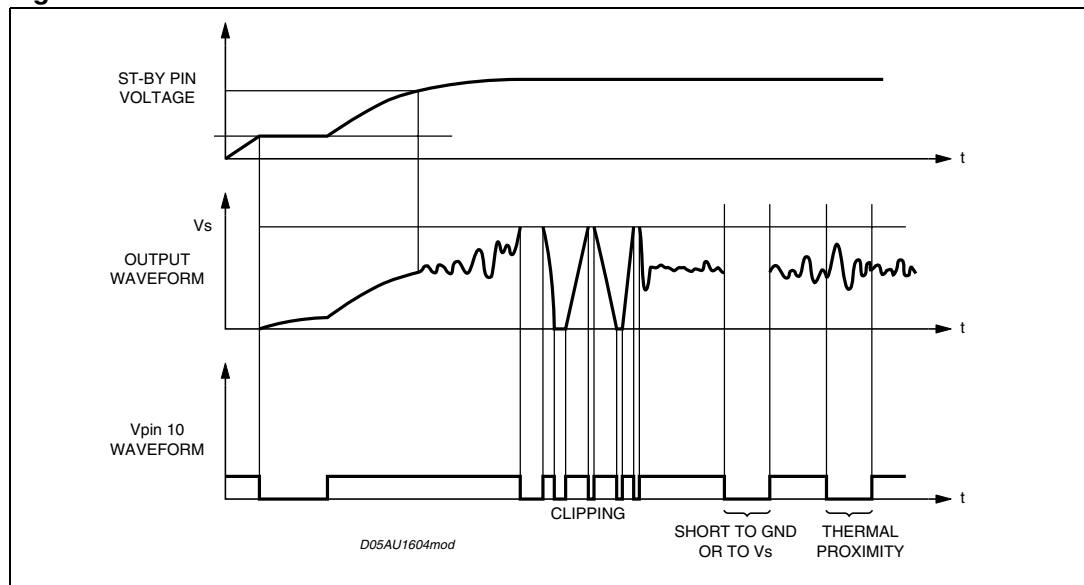
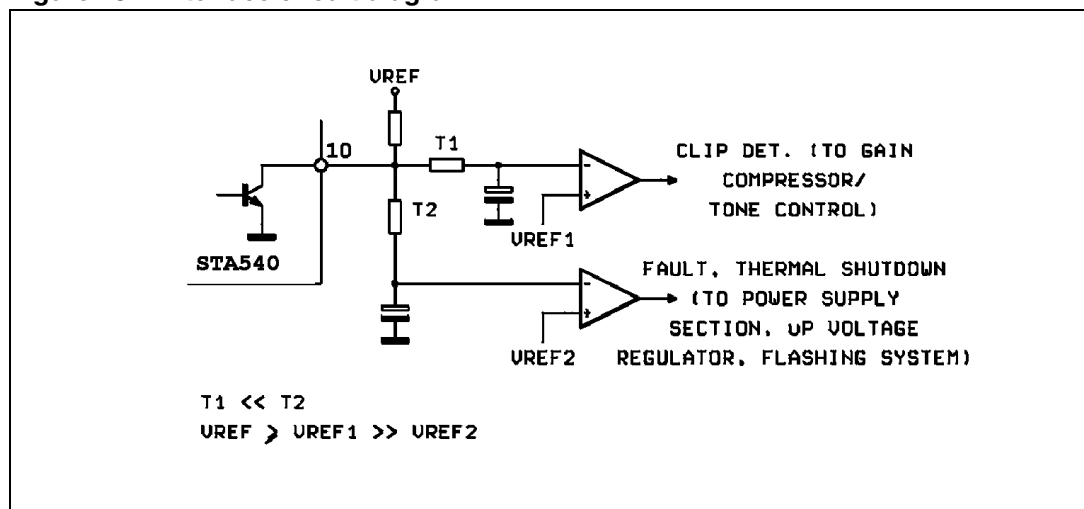

Figure 28. Interface circuit diagram



6.9 PCB ground layout

The device has two distinct ground pins, P-GND (power ground) and S-GND (signal ground) which are disconnected from each other at chip level. For superior performance the pins P-GND and S-GND must be connected together on the PCB by low-resistance tracks.

For the PCB-ground configuration, a star-like arrangement, where the center is represented by the supply-filtering electrolytic capacitor ground, is recommended. In an arrangement such as this, at least two separate paths must be provided, one for P-GND and one for S-GND.

The correct ground assignments are as follows:

- on S-GND:
 - standby capacitor (pin 7, or any other standby driving networks),
 - SVR capacitor (pin 6), to be placed as close as possible to the device,
 - input signal ground (from active/passive signal processor stages)
- on P-GND:
 - power supply filtering capacitors for pins 3 and 13. The negative terminal of the electrolytic capacitor(s) must be directly tied to the battery negative line and this should represent the starting point for all the ground paths.

6.10 Mute function

If the mute function is desired, it can be implemented on pin 6, SVR, as shown in [Figure 29](#).

Figure 29. Optional mute function circuit

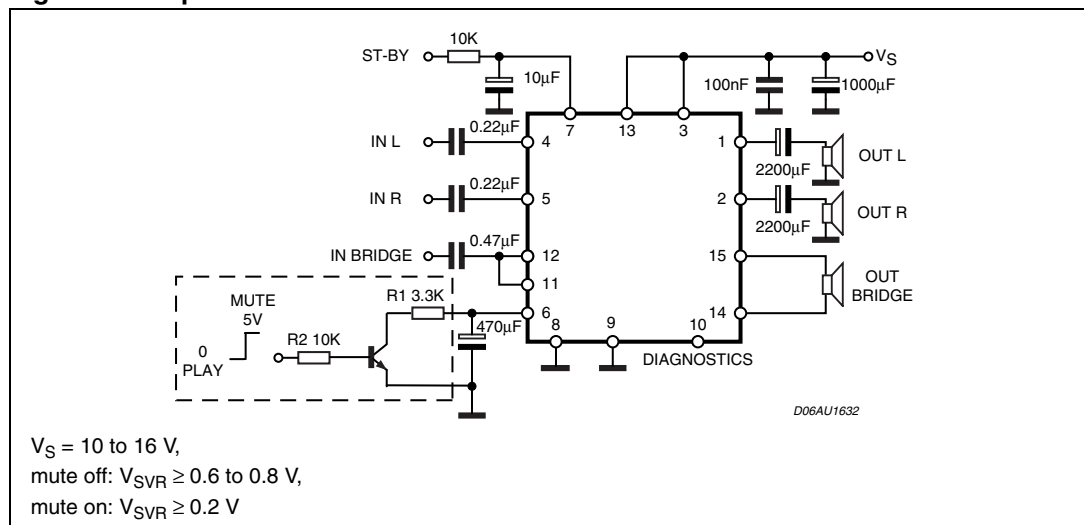

Using a different value for R1 than the suggested 3.3 kΩ, results in two different situations:

- $R1 > 3.3 \text{ k}\Omega$:
 - pop noise improvement,
 - lower mute attenuation;
- $R1 < 3.3 \text{ k}\Omega$:
 - pop noise degradation,
 - higher mute attenuation.

7 Package information

In order to meet environmental requirements, ST offers these devices in ECOPACK[®] packages. These packages have a Lead-free second level interconnect. The category of second Level Interconnect is marked on the package and on the inner box label, in compliance with JEDEC Standard JESD97. The maximum ratings related to soldering conditions are also marked on the inner box label. ECOPACK is an ST trademark. ECOPACK specifications are available at: www.st.com.

Figure 30. Mechanical data and package dimensions (Multiwatt15)

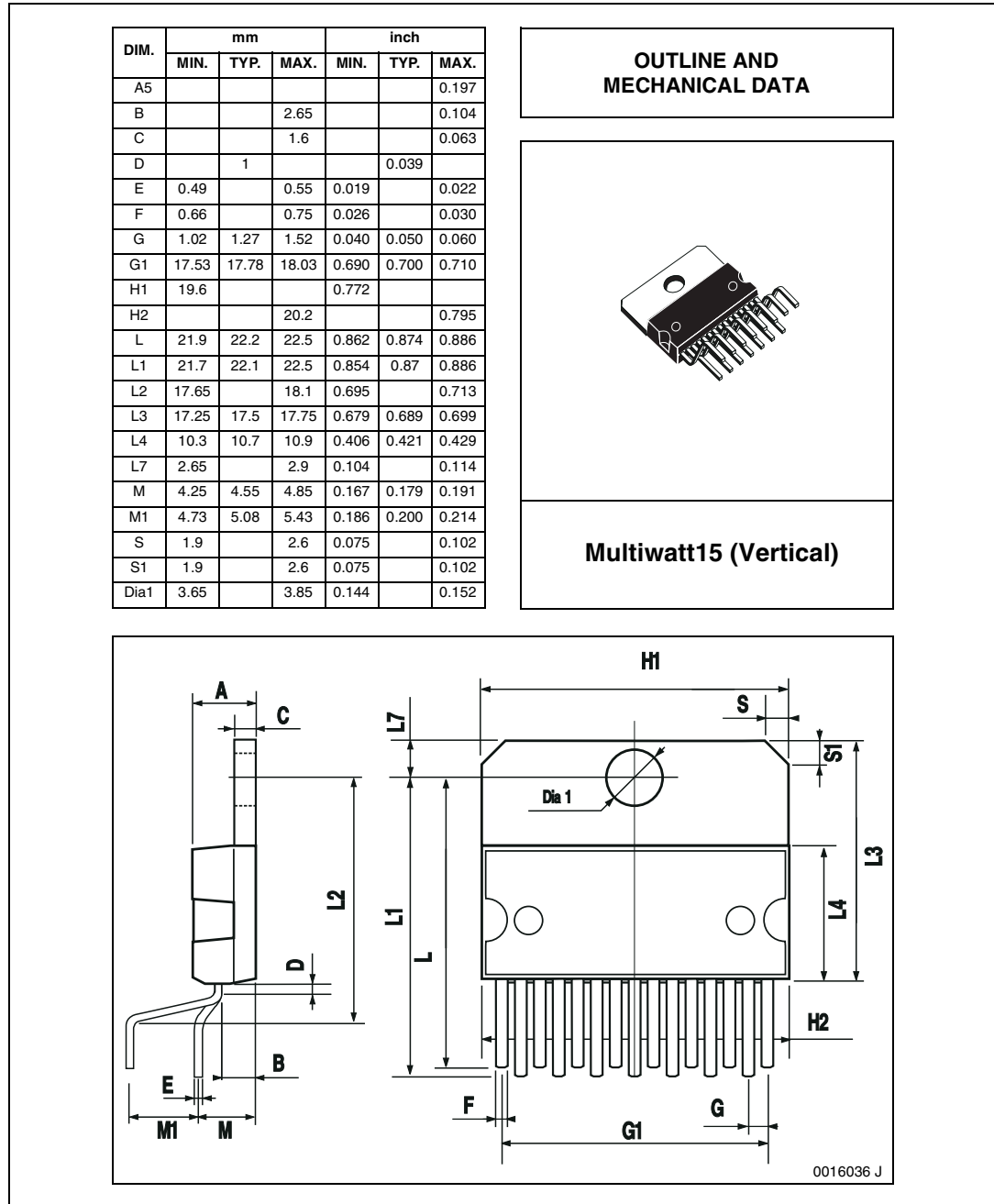

8 Revision history

Table 6. Document revision history

Date	Revision	Changes
21-Jan-2008	4	Updated power specifications on pages 1, 6 and 8 Updated short-circuit output current in Table 5
Oct-2007	3	Updated description on page 1 Updated pin naming, numbering in all relevant figures Minor non-technical edits
Sep-2006	2	Minor non-technical edits
May-2006	1	Initial release

Please Read Carefully:

Information in this document is provided solely in connection with ST products. STMicroelectronics NV and its subsidiaries ("ST") reserve the right to make changes, corrections, modifications or improvements, to this document, and the products and services described herein at any time, without notice.

All ST products are sold pursuant to ST's terms and conditions of sale.

Purchasers are solely responsible for the choice, selection and use of the ST products and services described herein, and ST assumes no liability whatsoever relating to the choice, selection or use of the ST products and services described herein.

No license, express or implied, by estoppel or otherwise, to any intellectual property rights is granted under this document. If any part of this document refers to any third party products or services it shall not be deemed a license grant by ST for the use of such third party products or services, or any intellectual property contained therein or considered as a warranty covering the use in any manner whatsoever of such third party products or services or any intellectual property contained therein.

UNLESS OTHERWISE SET FORTH IN ST'S TERMS AND CONDITIONS OF SALE ST DISCLAIMS ANY EXPRESS OR IMPLIED WARRANTY WITH RESPECT TO THE USE AND/OR SALE OF ST PRODUCTS INCLUDING WITHOUT LIMITATION IMPLIED WARRANTIES OF MERCHANTABILITY, FITNESS FOR A PARTICULAR PURPOSE (AND THEIR EQUIVALENTS UNDER THE LAWS OF ANY JURISDICTION), OR INFRINGEMENT OF ANY PATENT, COPYRIGHT OR OTHER INTELLECTUAL PROPERTY RIGHT.

UNLESS EXPRESSLY APPROVED IN WRITING BY AN AUTHORIZED ST REPRESENTATIVE, ST PRODUCTS ARE NOT RECOMMENDED, AUTHORIZED OR WARRANTED FOR USE IN MILITARY, AIR CRAFT, SPACE, LIFE SAVING, OR LIFE SUSTAINING APPLICATIONS, NOR IN PRODUCTS OR SYSTEMS WHERE FAILURE OR MALFUNCTION MAY RESULT IN PERSONAL INJURY, DEATH, OR SEVERE PROPERTY OR ENVIRONMENTAL DAMAGE. ST PRODUCTS WHICH ARE NOT SPECIFIED AS "AUTOMOTIVE GRADE" MAY ONLY BE USED IN AUTOMOTIVE APPLICATIONS AT USER'S OWN RISK.

Resale of ST products with provisions different from the statements and/or technical features set forth in this document shall immediately void any warranty granted by ST for the ST product or service described herein and shall not create or extend in any manner whatsoever, any liability of ST.

ST and the ST logo are trademarks or registered trademarks of ST in various countries.

Information in this document supersedes and replaces all information previously supplied.

The ST logo is a registered trademark of STMicroelectronics. All other names are the property of their respective owners.

© 2008 STMicroelectronics - All rights reserved

STMicroelectronics group of companies

Australia - Belgium - Brazil - Canada - China - Czech Republic - Finland - France - Germany - Hong Kong - India - Israel - Italy - Japan - Malaysia - Malta - Morocco - Singapore - Spain - Sweden - Switzerland - United Kingdom - United States of America

www.st.com