

## 40V 4.5A QUAD POWER HALF BRIDGE

### 1 FEATURES

- MULTIPOWER BCD TECHNOLOGY
- MINIMUM INPUT OUTPUT PULSE WIDTH DISTORTION
- 200m $\Omega$  R<sub>dsON</sub> COMPLEMENTARY DMOS OUTPUT STAGE
- CMOS COMPATIBLE LOGIC INPUTS
- THERMAL PROTECTION
- THERMAL WARNING OUTPUT
- UNDER VOLTAGE PROTECTION

### 2 DESCRIPTION

STA508 is a monolithic quad half bridge stage in Multipower BCD Technology. The device can be used as dual bridge or reconfigured, by connecting CONFIG pin to V<sub>dd</sub> pin, as single bridge with double current capability, and as half bridge (Binary mode) with half current capability.

**Figure 2. Block Diagram**

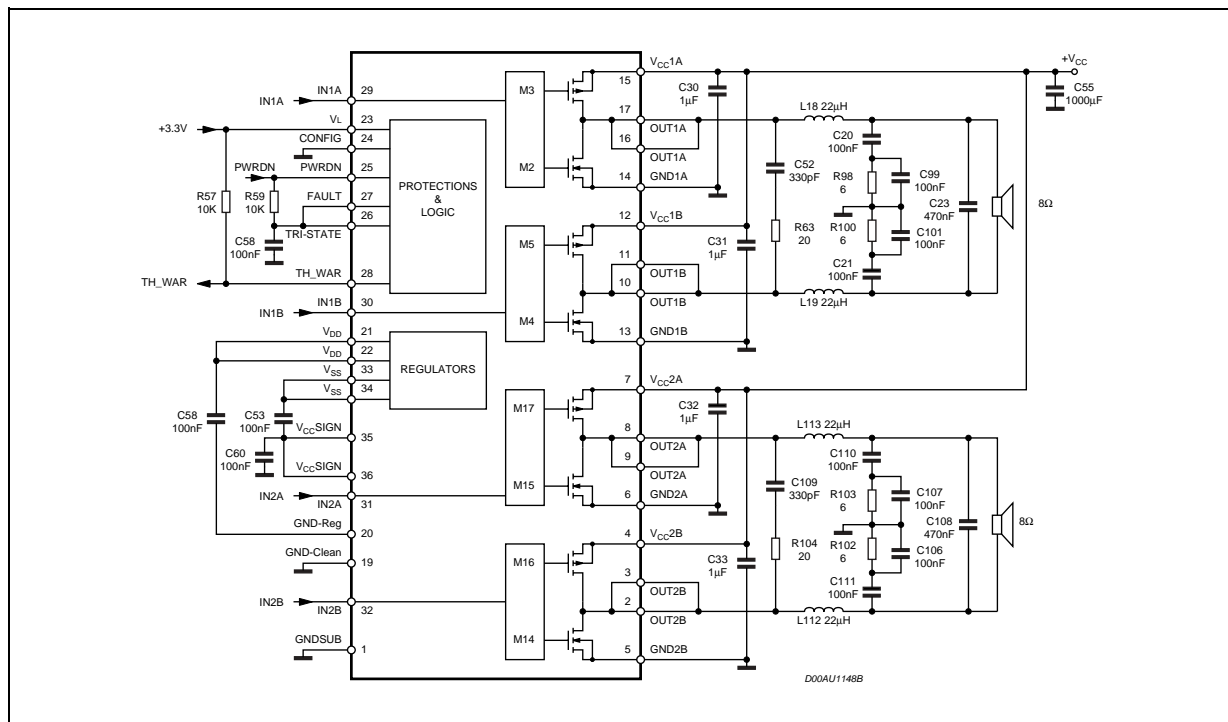

**Figure 1. Package**

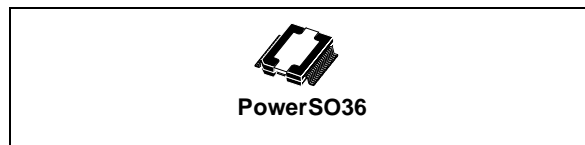

**Table 1. Order Codes**

Part Number	Package
STA508	PowerSO36

The device is particularly designed to make the output stage of a stereo All-Digital High Efficiency (DDX™) amplifier capable to deliver 80 + 80W @ THD = 10% at V<sub>CC</sub> 35V output power on 8 $\Omega$  load.

In single BTL configuration is also capable to deliver a peak of 160W @THD = 10% at V<sub>CC</sub> = 35V on 4 $\Omega$  load (t  $\leq$  1sec). The input pins have threshold proportional to I<sub>bias</sub> pin voltage.

Table 2. Pin Description

N°	Pin	Description
1	GND-SUB	Substrate Ground
2 ; 3	OUT2B	Output Half Bridge 2B
4	V <sub>CC</sub> 2B	Positive Supply
5	GND2B	Negative Supply
6	GND2A	Negative Supply
7	V <sub>CC</sub> 2A	Positive Supply
8 ; 9	OUT2A	Output Half Bridge 2A
10 ; 11	OUT1B	Output Half Bridge 1B
12	V <sub>CC</sub> 1B	Positive Supply
13	GND1B	Negative Supply
14	GND1A	Negative Supply
15	V <sub>CC</sub> 1A	Positive Supply
16 ; 17	OUT1A	Output Half Bridge 1A
18	NC	Not Connected
19	GND-clean	Logical Ground
20	GND-Reg	Ground for Regulator V <sub>dd</sub>
21 ; 22	V <sub>dd</sub>	5V Regulator Referred to Ground
23	V <sub>L</sub>	High Logical State Setting Voltage
24	CONFIG	Configuration pin
25	PWRDN	Stand-by pin
26	TRI-STATE	Hi-Z pin
27	FAULT	Fault pin Advisor
28	TH-WAR	Thermal Warning Advisor
29	IN1A	Input of Half Bridge 1A
30	IN1B	Input of Half Bridge 1B
31	IN2A	Input of Half Bridge 2A
32	IN2B	Input of Half Bridge 2B
33 ; 34	V <sub>SS</sub>	5V Regulator Referred to +V <sub>CC</sub>
35 ; 36	V <sub>CC</sub> Sign	Signal Positive Supply

**Table 3. FUNCTIONAL PIN STATUS**

PIN NAME	Logical value	IC -STATUS
FAULT	0	Fault detected (Short circuit, or Thermal ..)
FAULT (*)	1	Normal Operation
TRI-STATE	0	All powers in Hi-Z state
TRI-STATE	1	Normal operation
PWRDN	0	Low absorption
PWRDN	1	Normal operation
THWAR	0	Temperature of the IC =130°C
THWAR (*)	1	Normal operation
CONFIG	0	Normal Operation
CONFIG (**)	1	OUT1A = OUT1B ; OUT2A=OUT2B (IF IN1A = IN1B; IN2A = IN2B)

(\*) : The pin is open collector. To have the high logic value, it needs to be pulled up by a resistor.

(\*\*): To put CONFIG = 1 means connect Pin 24 (CONFIG) to Pins 21, 22 (Vdd)

**Figure 3. PIN CONNECTION**

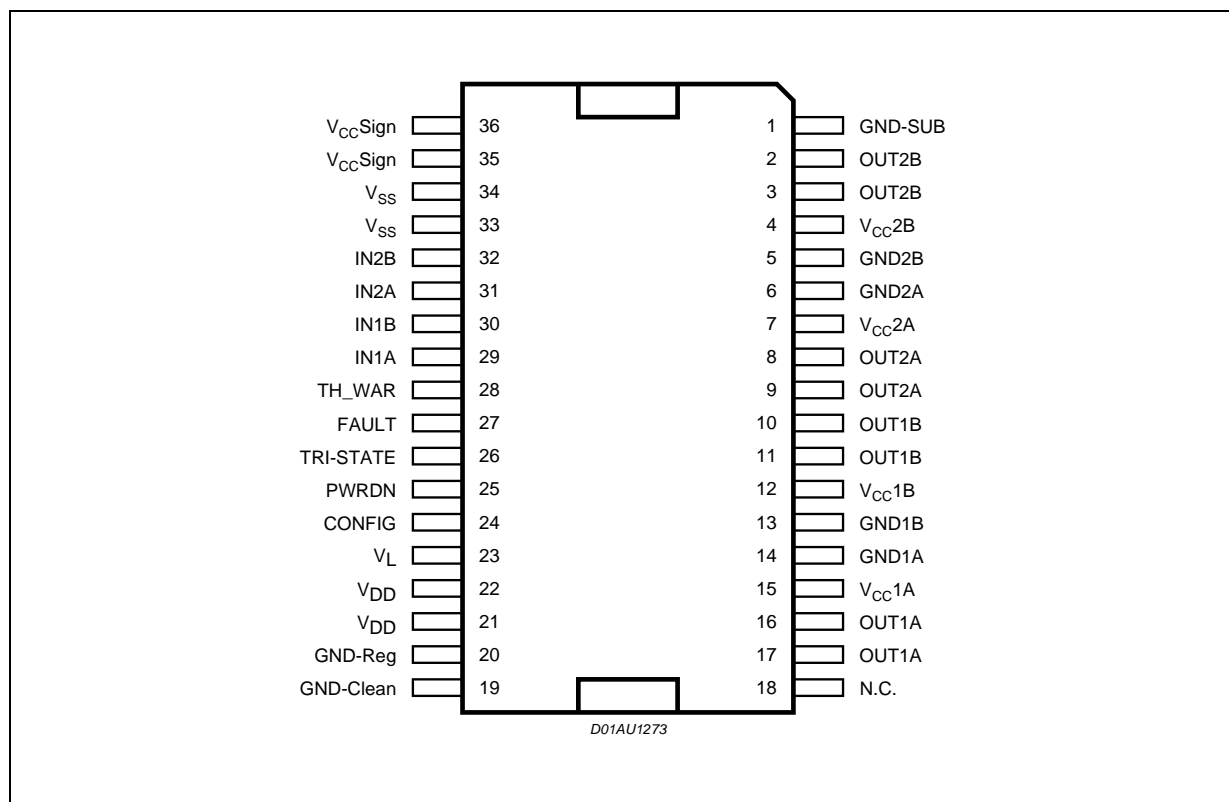

**Table 4. THERMAL DATA**

Symbol	Description	Value	Unit
R <sub>th j-case</sub>	Thermal Resistance Junction-case	max 1.5	°C/W

**Table 5. ABSOLUTE MAXIMUM RATINGS**

Symbol	Parameter	Value	Unit
$V_{CE}$	DC Supply Voltage (Pin 4,7,12,15)	40	V
$V_{max}$	Maximum Voltage on pins 23 to 32	5.5	V
$P_{tot}$	Power Dissipation ( $T_{case} = 70^{\circ}C$ )	50	W
$T_{op}$	Operating Temperature Range	0 to 70	$^{\circ}C$
$T_{stg}, T_j$	Storage and Junction Temperature	-40 to 150	$^{\circ}C$

**Table 6. ELECTRICAL CHARACTERISTICS** ( $V_L = 3.3V$ ;  $V_{CC} = 30V$ ;  $T_{amb} = 25^{\circ}C$  ;  $f_{sw} = 384$  unless otherwise specified)

Symbol	Parameter	Test conditions	Min.	Typ.	Max.	Unit
$R_{dsON}$	Power Pchannel/Nchannel MOSFET RdsON	$I_d=1A$		200	270	$m\Omega$
$I_{dss}$	Power Pchannel/Nchannel leakage $I_{dss}$	$V_{CC}=35V$			50	$\mu A$
$g_N$	Power Pchannel RdsON Matching	$I_d=1A$	95			%
$g_P$	Power Nchannel RdsON Matching	$I_d=1A$	95			%
$Dt_s$	Low current Dead Time (static)	see test circuit no.1; see fig. 4		10	20	ns
$Dt_d$	High current Dead Time (dynamic)	$L=22\mu H$ ; $C = 470nF$ ; $R_L = 8 \Omega$ $I_d=3.5A$ ; see fig. 3			50	ns
$t_{d ON}$	Turn-on delay time	Resistive load			100	ns
$t_{d OFF}$	Turn-off delay time	Resistive load			100	ns
$t_r$	Rise time	Resistive load; as fig.4			25	ns
$t_f$	Fall time	Resistive load; as fig. 4			25	ns
$V_{CC}$	Supply voltage operating voltage		9		36	V
$V_{IN-High}$	High level input voltage				$V_L/2 + 300mV$	V
$V_{IN-Low}$	Low level input voltage		$V_L/2 - 300mV$			V
$I_{IN-High}$	High level Input current	Pin Voltage = $V_L$		1		$\mu A$
$I_{IN-Low}$	Low level input current	Pin Voltage = 0.3V		1		$\mu A$
$I_{PWRDN-H}$	High level PWRDN pin input current	$V_L = 3.3V$		35		$\mu A$
$V_L$	Low logical state voltage $V_L$ (pin PWRDN, TRISTATE) (note 1)	$V_L = 3.3V$	0.8			V

**Table 6. ELECTRICAL CHARACTERISTICS** (continued)

Symbol	Parameter	Test conditions	Min.	Typ.	Max.	Unit
V <sub>H</sub>	High logical state voltage V <sub>H</sub> (pin PWRDN, TRISTATE) (note 1)	V <sub>L</sub> = 3.3V			1.7	V
I <sub>VCC-PWRDN</sub>	Supply CURRENT from Vcc in Power Down	PWRDN = 0			3	mA
I <sub>FAULT</sub>	Output Current pins FAULT -TH-WARN when FAULT CONDITIONS	V <sub>pin</sub> = 3.3V		1		mA
I <sub>VCC-hiz</sub>	Supply Current from Vcc in Tri-state	V <sub>CC</sub> = 30V; Tri-state = 0		22		mA
I <sub>VCC</sub>	Supply Current from Vcc in operation both channel switching)	V <sub>CC</sub> = 30V; Input Pulse width = 50% Duty; Switching Frequency = 384KHz; No LC filters;		50		mA
I <sub>VCC-q</sub>	I <sub>sc</sub> (short circuit current limit) (note 2)		4.5	6	9	A
V <sub>OUT-SH</sub>	Undervoltage protection threshold			7		V
V <sub>OV</sub>	Output minimum pulse width	No Load	70		150	ns

**Table 7.**

Notes: 1. The following table explains the V<sub>Low</sub>, V<sub>High</sub> variation with I<sub>bias</sub>

V <sub>L</sub>	V <sub>Low min</sub>	V <sub>High max</sub>	Unit
2.7	0.7	1.5	V
3.3	0.8	1.7	V
5	0.85	1.85	V

Note 2: See relevant Application Note AN1994

**Table 8. LOGIC TRUTH TABLE** (see fig. 5)

TRI-STATE	INxA	INxB	Q1	Q2	Q3	Q4	OUTPUT MODE
0	x	x	OFF	OFF	OFF	OFF	Hi-Z
1	0	0	OFF	OFF	ON	ON	DUMP
1	0	1	OFF	ON	ON	OFF	NEGATIVE
1	1	0	ON	OFF	OFF	ON	POSITIVE
1	1	1	ON	ON	OFF	OFF	Not used

Figure 4. Test Circuit.

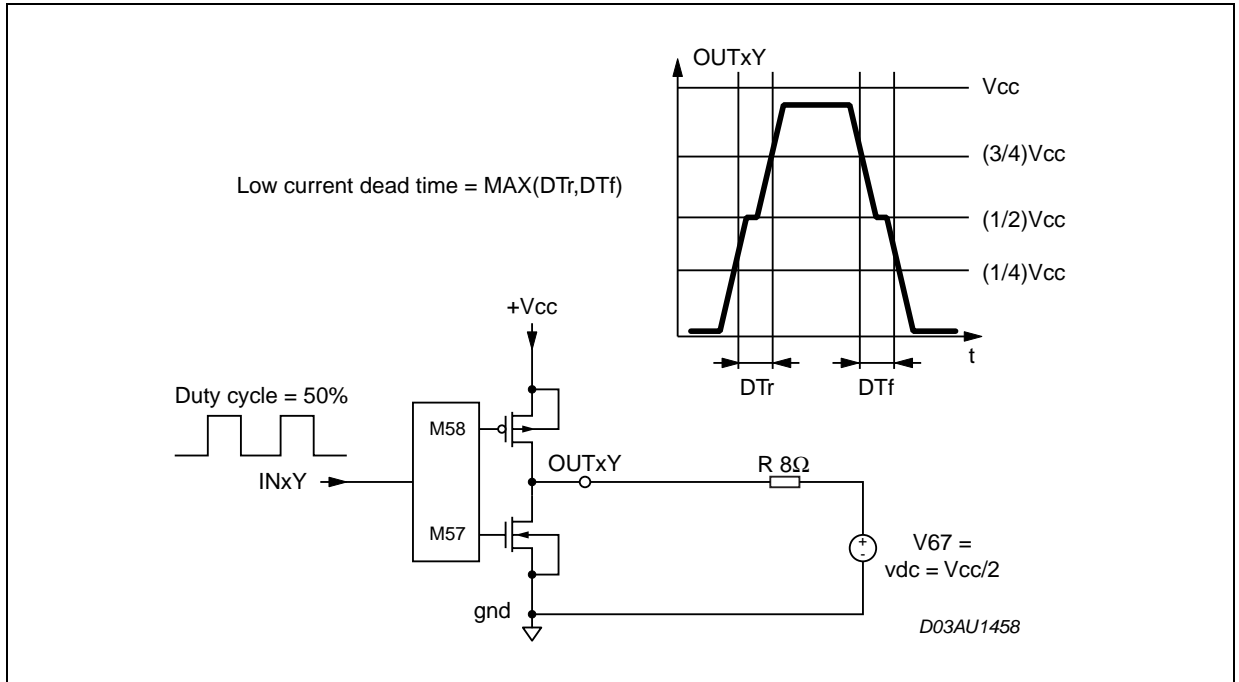

Figure 5.

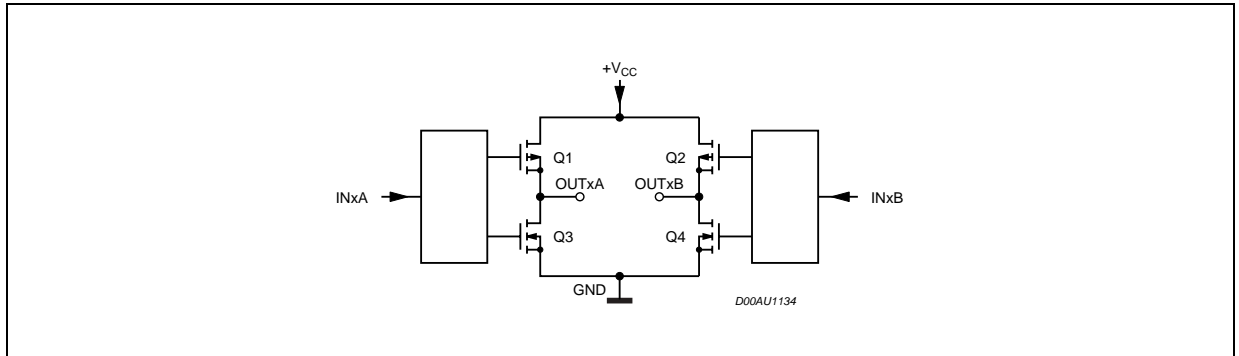

Figure 6.

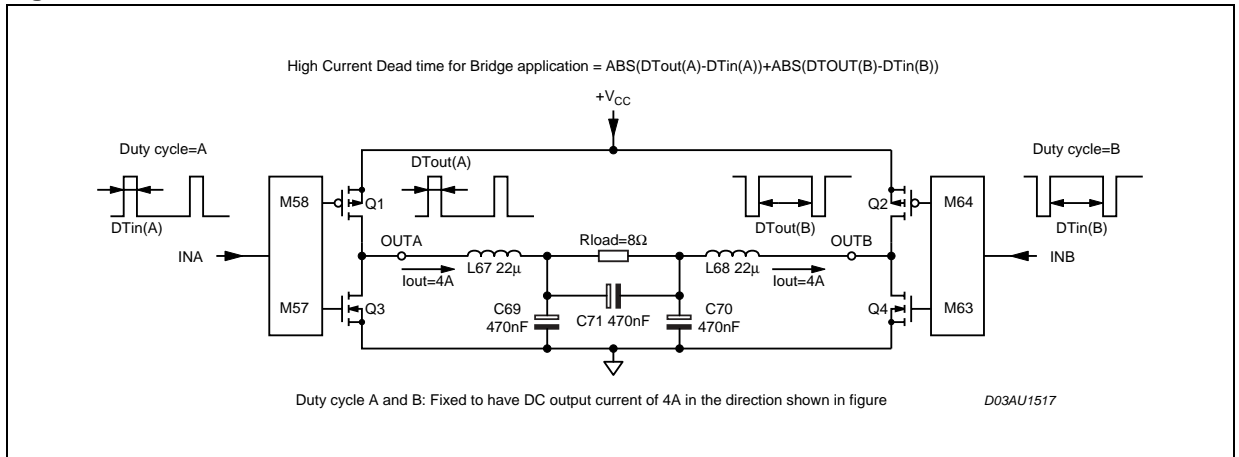

Figure 7. Typical Single BTL Configuration

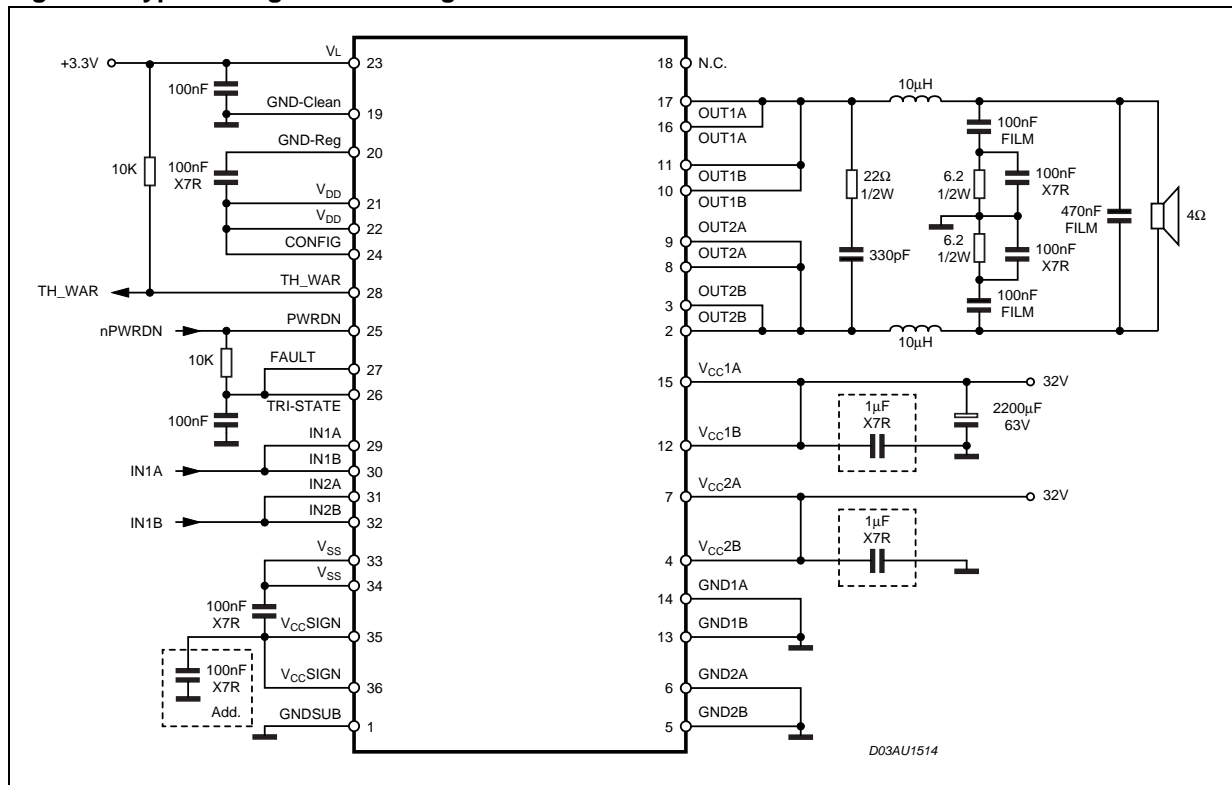
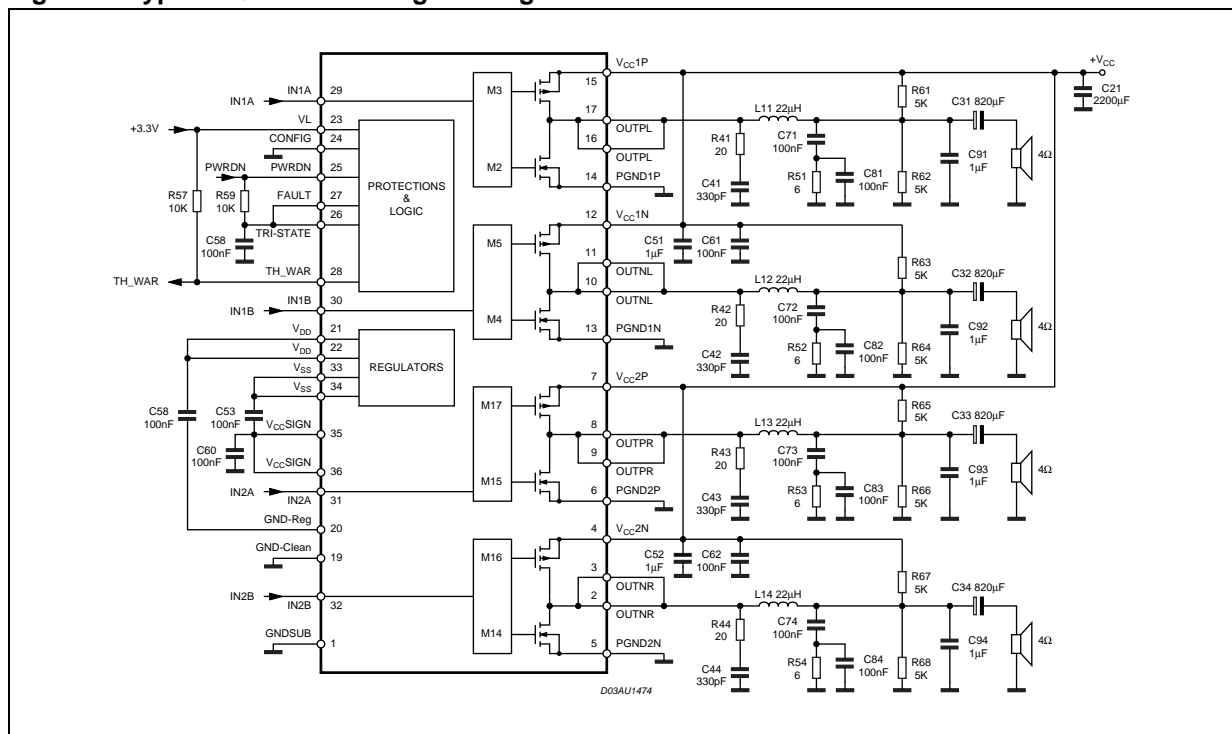

Figure 8. Typical Quad Half Bridge Configuration



For more information refer to the application notes AN1456 and AN1661

Figure 9. Power SO36 (SLUG UP) Mechanical Data & Package Dimensions

DIM.	mm			inch		
	MIN.	TYP.	MAX.	MIN.	TYP.	MAX.
A	3.25		3.43	0.128		0.135
A2	3.1		3.2	0.122		0.126
A4	0.8		1	0.031		0.039
A5		0.2			0.008	
a1	0.030		-0.040	0.0011		-0.0015
b	0.22		0.38	0.008		0.015
c	0.23		0.32	0.009		0.012
D	15.8		16	0.622		0.630
D1	9.4		9.8	0.37		0.38
D2		1			0.039	
E	13.9		14.5	0.547		0.57
E1	10.9		11.1	0.429		0.437
E2			2.9			0.114
E3	5.8		6.2	0.228		0.244
E4	2.9		3.2	0.114		1.259
e		0.65			0.026	
e3		11.05			0.435	
G	0		0.075	0		0.003
H	15.5		15.9	0.61		0.625
h			1.1			0.043
L	0.8		1.1	0.031		0.043
N	10° (max)					
s	8° (max)					

OUTLINE AND MECHANICAL DATA

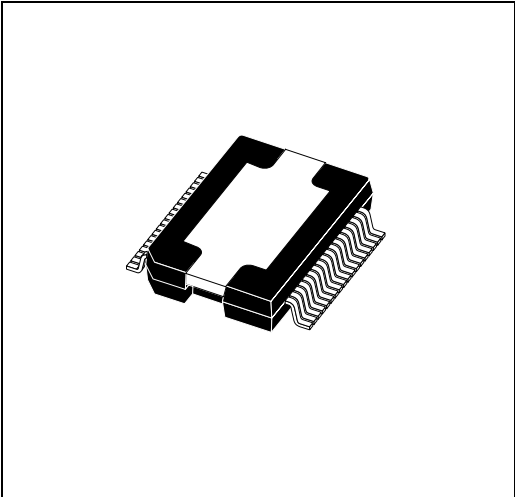

PowerSO36 (SLUG UP)

- (1) "D and E1" do not include mold flash or protrusions. Mold flash or protrusions shall not exceed 0.15mm (0.006")
- (2) No intrusion allowed inwards the leads.

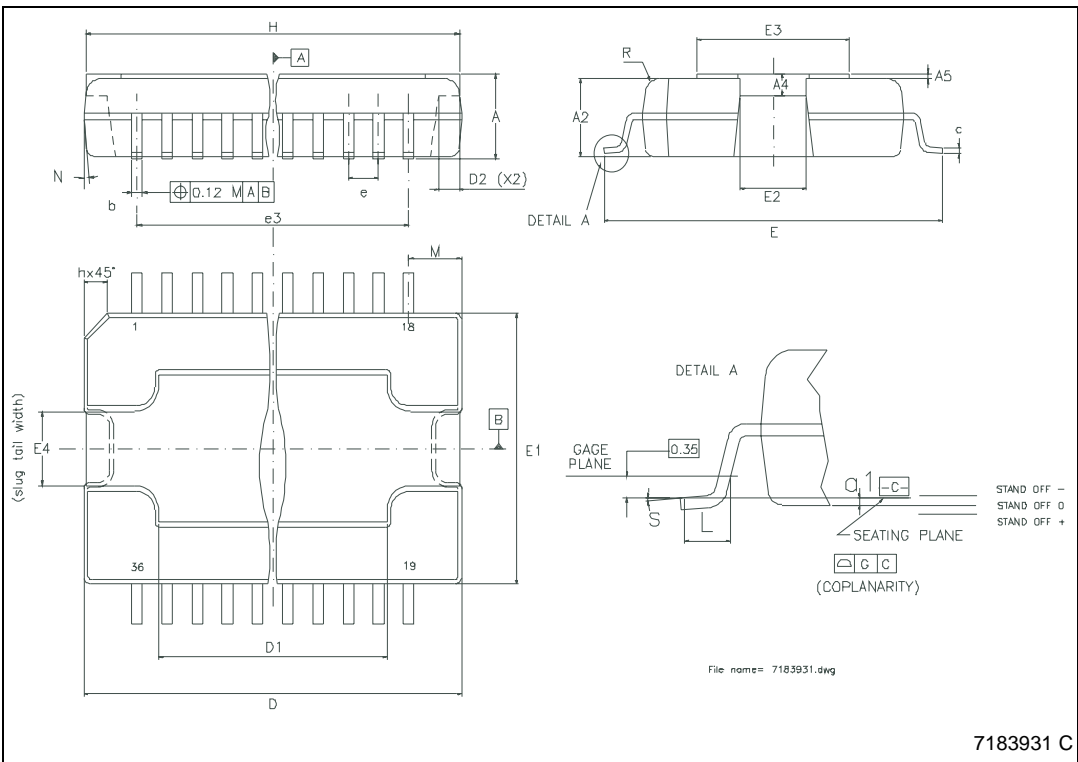

7183931 C



**Table 9. Revision History**

Date	Revision	Description of Changes
September 1994	1	First Issue
June 2004	2	Note 2: See relevant Application Note AN1994

Information furnished is believed to be accurate and reliable. However, STMicroelectronics assumes no responsibility for the consequences of use of such information nor for any infringement of patents or other rights of third parties which may result from its use. No license is granted by implication or otherwise under any patent or patent rights of STMicroelectronics. Specifications mentioned in this publication are subject to change without notice. This publication supersedes and replaces all information previously supplied. STMicroelectronics products are not authorized for use as critical components in life support devices or systems without express written approval of STMicroelectronics.

The ST logo is a registered trademark of STMicroelectronics.  
All other names are the property of their respective owners

© 2004 STMicroelectronics - All rights reserved

**STMicroelectronics GROUP OF COMPANIES**

Australia - Belgium - Brazil - Canada - China - Czech Republic - Finland - France - Germany - Hong Kong - India - Israel - Italy - Japan -  
Malaysia - Malta - Morocco - Singapore - Spain - Sweden - Switzerland - United Kingdom - United States  
[www.st.com](http://www.st.com)