



# ST3485E

## 3.3V POWERED, 15KV ESD PROTECTED, TRANSMIT AT UP TO 12MBPS TRUE RS-485/RS-422 TRANSCEIVER

- ESD PROTECTION:
  - ±15KV HUMAN BODY MODEL
  - ±8KV IEC 1000-4-2 CONTACT DISCHARGE
- OPERATE FROM A SINGLE 3.3V SUPPLY - NO CHARGE PUMP REQUIRED
- INTEROPERABLE WITH 5V LOGIC
- 1µA LOW CURRENT SHUTDOWN MODE MAX
- GUARANTEED 12 Mbps DATA RATE
- -7 TO 12 COMMON MODE INPUT VOLTAGE RANGE
- HALF DUPLEX VERSIONS AVAILABLE
- INDUSTRY STANDARD 75176 PINOUT
- CURRENT LIMITING AND THERMAL SHUTDOWN FOR DRIVER OVERLOAD PROTECTION
- GUARANTEED HIGH RECEIVER OUTPUT STATE FOR FLOATING INPUTS WITH NO SIGNAL PRESENT
- ALLOW UP TO 64 TRANSCEIVERS ON THE BUS

### DESCRIPTION

The ST3485E is ±15kV ESD protected, 3.3V low power transceiver for RS-485 and RS-422 communications. The device contains one driver

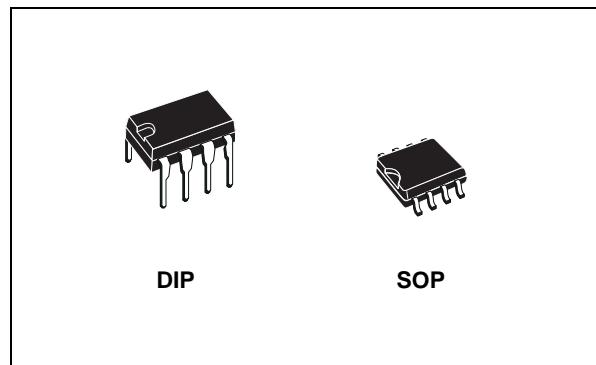

and one receiver in half duplex configuration. The ST3485E transmit and receive at guaranteed data rate at least to 12Mbps.

All transmitter outputs and receiver inputs are protected to ±15kV using Human Body Model. Driver is short-circuit current limited and is protected against excessive power dissipation by thermal shutdown circuitry that place the driver outputs into a high-impedance state.

The ST3485E input has a true fail-safe feature that guarantees a logic high output if both inputs are open circuit, shorted together or in presence of the termination with no signal on the bus.

### ORDERING CODES

Type	Temperature Range	Package	Comments
ST3485ECN	0 to 70 °C	DIP-8	50parts per tube / 40tube per box
ST3485EBN	-40 to 85 °C	DIP-8	50parts per tube / 40tube per box
ST3485ECD	0 to 70 °C	SO-8 (Tube)	100parts per tube / 20tube per box
ST3485EBD	-40 to 85 °C	SO-8 (Tube)	100parts per tube / 20tube per box
ST3485ECDR	0 to 70 °C	SO-8 (Tape & Reel)	2500 parts per reel
ST3485EBDR	-40 to 85 °C	SO-8 (Tape & Reel)	2500 parts per reel

**PIN CONFIGURATION**

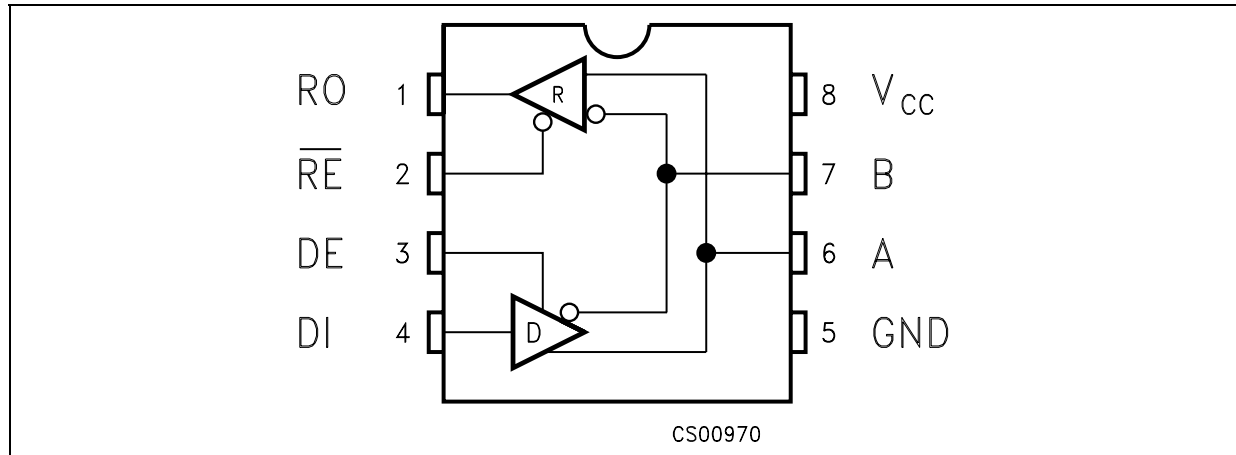

**PIN DESCRIPTION**

PIN N°	SYMBOL	NAME AND FUNCTION
1	RO	Receiver Output. If A>B by 200mV, RO will be high; if A<B by 200mV, RO will be low
2	$\overline{RE}$	Receiver Output Enable. RO is enabled when RE is low; RO is high impedance when RE is high. If RE is high and DE is low, the device will enter a low power shutdown mode.
3	DE	Driver Output Enable. The driver outputs are enabled by bringing DE high. They are high impedance when DE is low. If RE is high DE is low, the device will enter a low-power shutdown mode. If the driver outputs are enabled, the part functions as line driver, while they are high impedance, it functions as line receivers if RE is low.
4	DI	Driver Input. A low on DI forces output A low and output B high. Similarly, a high on DI forces output A high and output B low
5	GND	Ground
6	A	Non-inverting Receiver Input and Non-inverting Driver Output
7	B	Inverting Receiver Input and Inverting Driver Output
8	V <sub>CC</sub>	Supply Voltage: V <sub>CC</sub> = 3V to 3.6V

**TRUTH TABLE (DRIVER)**

INPUTS			OUTPUTS		MODE
$\overline{RE}$	DE	DI	B	A	
X	H	H	L	H	Normal
X	H	L	H	L	Normal
L	L	X	Z	Z	Normal
H	L	X	Z	Z	Shutdown

X= Don't Care; Z=High Impedance

**TRUTH TABLE (RECEIVER)**

INPUTS			OUTPUT	MODE
$\overline{RE}$	DE	A-B	RO	
L	L	$\geq -0.015V$	H	Normal
L	L	$\leq -0.2V$	L	Normal
L	L	Inputs Open	H	Normal
L	L	Inputs Shorted	H	Normal
H	L	X	Z	Shutdown

X= Don't Care; Z=High Impedance

**ABSOLUTE MAXIMUM RATINGS**

Symbol	Parameter	Value	Unit
$V_{CC}$	Supply Voltage	7	V
$V_I$	Control Input Voltage (RE, DE)	-0.3 to 7	V
$V_{DI}$	Driver Input Voltage (DI)	-0.3 to 7	V
$V_{DO}$	Driver Output Voltage (A, B)	-7.5 to 12.5	V
$V_{RI}$	Receiver Input Voltage (A, B)	-7.5 to 12.5	V
$V_{RO}$	Receiver Output Voltage (RO)	-0.3 to ( $V_{CC} + 0.3$ )	V

Absolute Maximum Ratings are those values beyond which damage to the device may occur. Functional operation under these condition is not implied.

**ESD PERFORMANCE: TRANSMITTER OUTPUTS, RECEIVER INPUTS**

Symbol	Parameter	Test Conditions	Min.	Typ.	Max.	Unit
ESD	ESD Protection Voltage	Human Body Model		$\pm 15$		KV
ESD	ESD Protection Voltage	IEC-1000-4-2 Contact Discharge		$\pm 8$		KV

**ELECTRICAL CHARACTERISTICS**

$V_{CC} = 3V$  to  $3.6V$ ,  $T_A = -40$  to  $85^\circ C$ , unless otherwise specified. Typical values are referred to  $T_A = 25^\circ C$ )

Symbol	Parameter	Test Conditions	Min.	Typ.	Max.	Unit
$I_{SUPPLY}$	$V_{CC}$ Power Supply Current	No Load, DI=0V or $V_{CC}$ DE= $V_{CC}$ , RE=0V or $V_{CC}$		1.3	2.2	mA
				1.2	1.9	mA
$I_{SHDN}$	Shutdown Supply Current	DE=0V, RE= $V_{CC}$ , DI=0V or $V_{CC}$		0.002	1	$\mu A$

**LOGIC INPUT ELECTRICAL CHARACTERISTICS**

$V_{CC} = 3V$  to  $3.6V$ ,  $T_A = -40$  to  $85^\circ C$ , unless otherwise specified. Typical values are referred to  $T_A = 25^\circ C$ )

Symbol	Parameter	Test Conditions	Min.	Typ.	Max.	Unit
$V_{IL}$	Input Logic Threshold Low	DE, DI, RE		1.3	0.8	V
$V_{IH}$	Input Logic Threshold High	DE, DI, RE	2			V
$I_{IN1}$	Logic Input Current	DE, DI, RE			$\pm 2.0$	$\mu A$
$I_{IN2}$	Input Current (A, B)	DE=0V, $V_{CC} = 0$ or $3.6V$ $V_{IN} = 12V$			1	mA
					-0.8	mA

**TRANSMITTER ELECTRICAL CHARACTERISTICS**

$V_{CC} = 3V$  to  $3.6V$ ,  $T_A = -40$  to  $85^\circ C$ , unless otherwise specified. Typical values are referred to  $T_a = 25^\circ C$ )

Symbol	Parameter	Test Conditions	Min.	Typ.	Max.	Unit
$V_{OD}$	Differential Drive Output	$R_L = 100\Omega$ (RS-422) (Figure 1)	2			V
		$R_L = 54\Omega$ (RS-485) (Figure 1)	1.5			V
		$R_L = 60\Omega$ (RS-485) (Figure 2)	1.5			V
$\Delta V_{OD}$	Change in magnitude of Driver Differential Output Voltage for Complementary Output States (Note1)	$R_L = 54\Omega$ or $100\Omega$ (Figure 1)			0.2	V
$V_{OC}$	Driver Common Mode Output Voltage	$R_L = 54\Omega$ or $100\Omega$ (Figure 1)			3	V
$\Delta V_{OC}$	Change in magnitude of Driver Common Mode Output Voltage (Note1)	$R_L = 54\Omega$ or $100\Omega$ (Figure 1)			0.2	V
$I_{OSD}$	Driver Short Circuit Output Current				$\pm 250$	mA

**RECEIVER ELECTRICAL CHARACTERISTICS**

$V_{CC} = 3V$  to  $3.6V$ ,  $T_A = -40$  to  $85^\circ C$ , unless otherwise specified. Typical values are referred to  $T_a = 25^\circ C$ )

Symbol	Parameter	Test Conditions	Min.	Typ.	Max.	Unit
$V_{TH}$	Receiver Differential Threshold Voltage	$V_{CM} = -7V$ to $12V$ , $DE = 0$	-0.2		-0.015	V
$\Delta V_{TH}$	Receiver Input Hysteresis	$V_{CM} = 0V$		30		V
$V_{OH}$	Receiver Output High Voltage	$I_{OUT} = -4mA$ , $V_{ID} = 200mV$ , (Figures 8,9)	2			V
$V_{OL}$	Receiver Output Low Voltage	$I_{OUT} = 4mA$ , $V_{ID} = -200mV$ , (Figure 3)			0.4	V
$I_{OZR}$	3-State (High Impedance) Output Current at Receiver	$V_{CC} = 3.6V$ $V_O = 0V$ to $V_{CC}$			$\pm 1$	$\mu A$
$R_{RIN}$	Receiver Input Resistance	$V_{CM} = -7V$ to $12V$	24			$K\Omega$
$I_{OSR}$	Receiver Short-Circuit Current	$V_{RO} = 0V$ to $V_{CC}$	7		60	mA

**DRIVER SWITCHING CHARACTERISTICS**

$V_{CC} = 3V$  to  $3.6V$ ,  $T_A = -40$  to  $85^\circ C$ , unless otherwise specified. Typical values are referred to  $T_a = 25^\circ C$ )

Symbol	Parameter	Test Conditions	Min.	Typ.	Max.	Unit
$D_R$	Maximum Data Rate		12	15		Mbps
$t_{DD}$	Differential Output Delay	$R_L = 60\Omega$ $C_L = 15pF$ , (Figures 4,5)		18	30	ns
$t_{TD}$	Differential Output Transition Time	$R_L = 60\Omega$ $C_L = 15pF$ , (Figures 4,5)		12	20	ns
$t_{PLH}$ $t_{PHL}$	Propagation Delay	$R_L = 27\Omega$ $C_L = 15pF$ , (Figures 8,9)		18	30	ns
$t_{PDS}$	$ t_{PLH} - t_{PHL} $ Propagation Delay Skew (Note2)	$R_L = 27\Omega$ $C_L = 15pF$ , (Figures 8,9)		2	5	ns
$t_{PZL}$	Output Enable Time	$R_L = 110\Omega$ (Figures 10,11)		19	35	ns
$t_{PZH}$	Output Enable Time	$R_L = 110\Omega$ (Figures 6,7)		30	50	ns
$t_{PHZ}$	Output Disable Time	$R_L = 110\Omega$ (Figures 6,7)		19	35	ns
$t_{PLZ}$	Output Disable Time	$R_L = 110\Omega$ (Figures 10,11)		30	50	ns
$t_{SKEW}$	Differential Output Delay Skew			1	3	ns
$t_{ZH(SHDN)}$	Driver Enable from Shutdown to Output High			30	50	ns
$t_{ZL(SHDN)}$	Driver Enable from Shutdown to Output Low			19	35	ns

**RECEIVER SWITCHING CHARACTERISTICS**

$V_{CC} = 3V$  to  $3.6V$ ,  $T_A = -40$  to  $85^\circ C$ , unless otherwise specified. Typical values are referred to  $T_a = 25^\circ C$ )

Symbol	Parameter	Test Conditions	Min.	Typ.	Max.	Unit
$t_{PLH}$ $t_{PHL}$	Propagation Delay	$V_{ID} = 0V$ to $3V$ $C_{L1} = 15pF$ , (Figures 12,13)		30	50	ns
$t_{RPDS}$	$ t_{PLH} - t_{PHL} $ Propagation Delay Skew	$V_{ID} = 0V$ to $3V$ $C_{L1} = 15pF$ , (Figures 12,13)		1	3	ns
$t_{PZL}$	Output Enable Time	$C_{RL} = 15pF$ (Figures 14-18)		10	20	ns
$t_{PZH}$	Output Enable Time	$C_{RL} = 15pF$ (Figures 14-18)		10	20	ns
$t_{PHZ}$	Output Disable Time	$C_{RL} = 15pF$ (Figures 14-18)		10	20	ns
$t_{PLZ}$	Output Disable Time	$C_{RL} = 15pF$ (Figures 14-18)		10	20	ns
$t_{ZH(SHDN)}$	Receiver Enable from Shutdown to Output High	$C_{RL} = 15pF$ (Figures 14-18)		10	20	ns
$t_{ZL(SHDN)}$	Receiver Enable from Shutdown to Output Low	$C_{RL} = 15pF$ (Figures 14-18)		20	40	ns

Note 1:  $\Delta V_{OD}$  and  $\Delta V_{OC}$  are the changes in  $V_{OD}$  and  $V_{OC}$ , respectively, when the DI input changes state.

Note 2: measured on  $|t_{PLH}(A) - t_{PHL}(A)|$  and  $|t_{PLH}(B) - t_{PHL}(B)|$

Note 3: The transceivers are put into shutdown by bring RE high and DE low. If the input are in state for less than 80ns, the part are guaranteed not to enter shutdown. If the inputs are in this state for at least 300ns, the parts are guaranteed to have entered shutdown.

TEST CIRCUITS AND TYPICAL CHARACTERISTICS

Figure 1 : Driver and  $V_{OC}$  Test Load

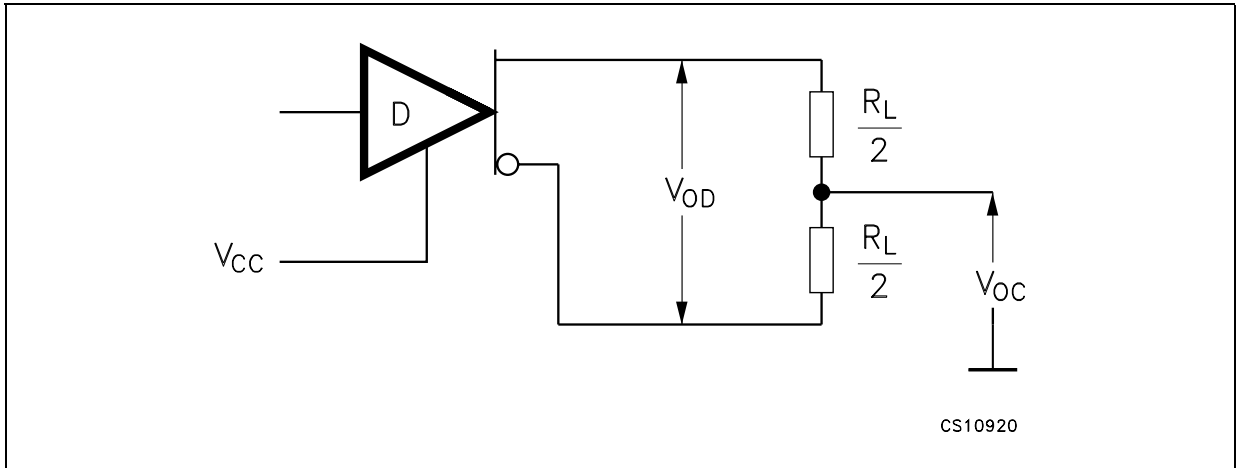

Figure 2 : Driver  $V_{OD}$  with Varying Common Mode Voltage Test Load

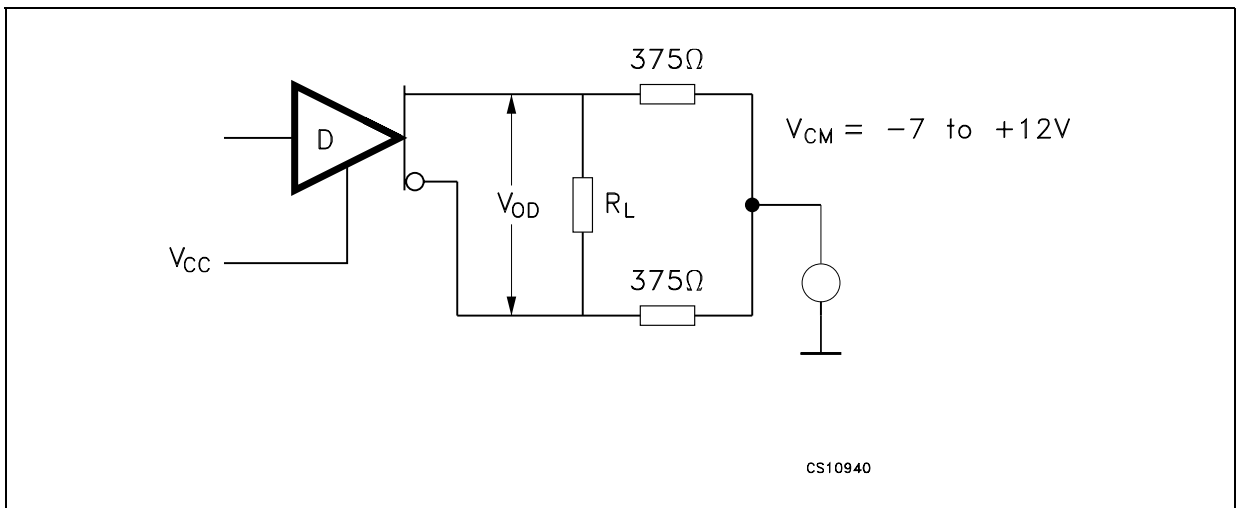

Figure 3 : Receiver  $V_{OH}$  and  $V_{OL}$  Test Circuit

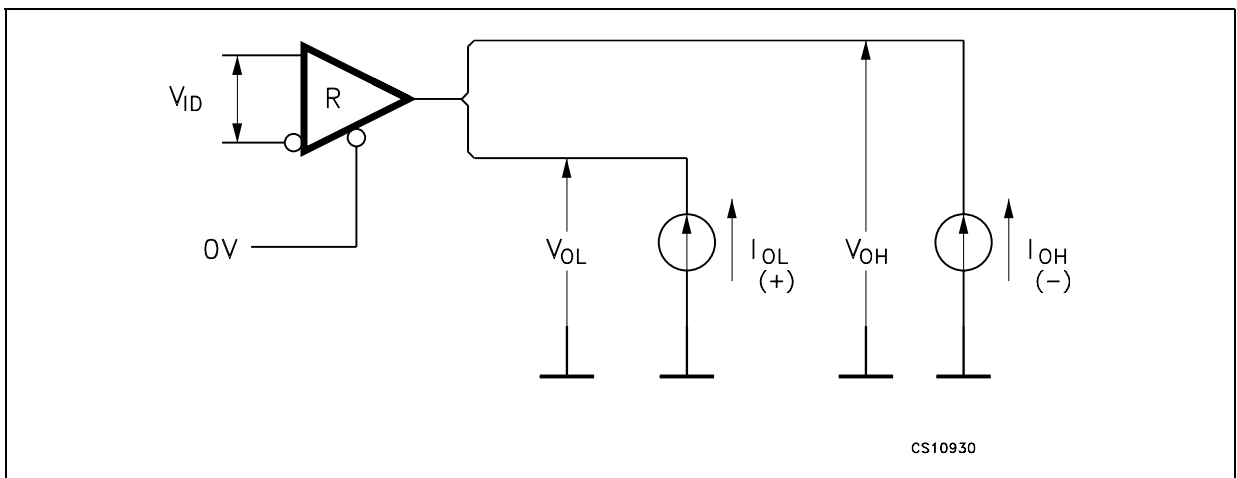

Figure 4 : Drive Differential Output Delay Transition Time Test Circuit

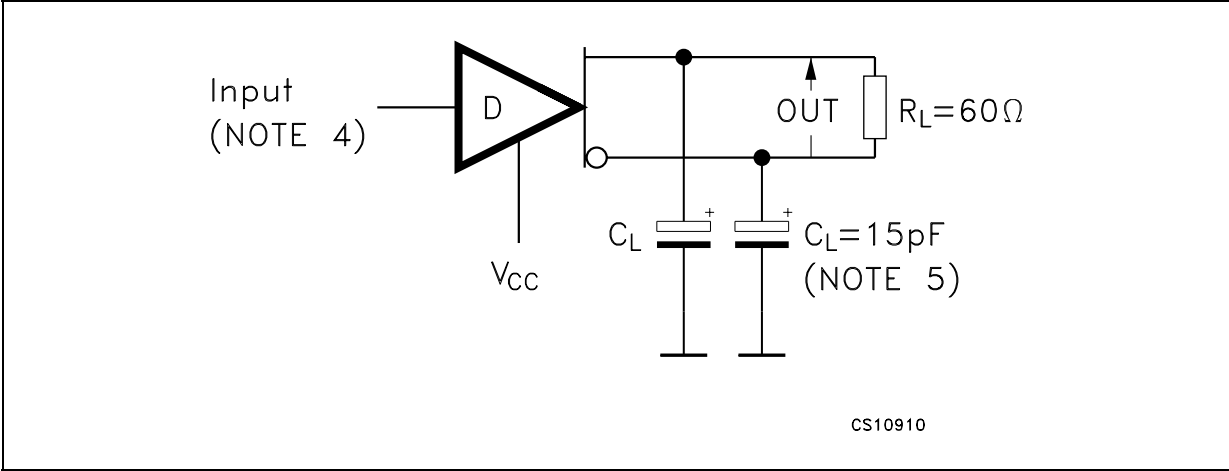

Figure 5 : Drive Differential Output Delay Transition Time Waveform

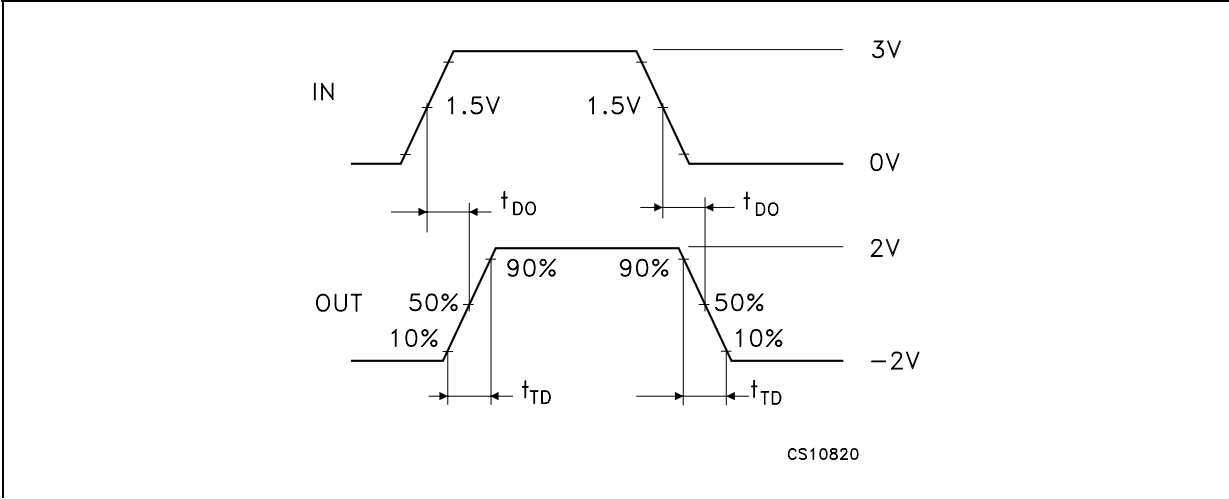

Figure 6 : Drive Enable and Disable Times Test Circuit

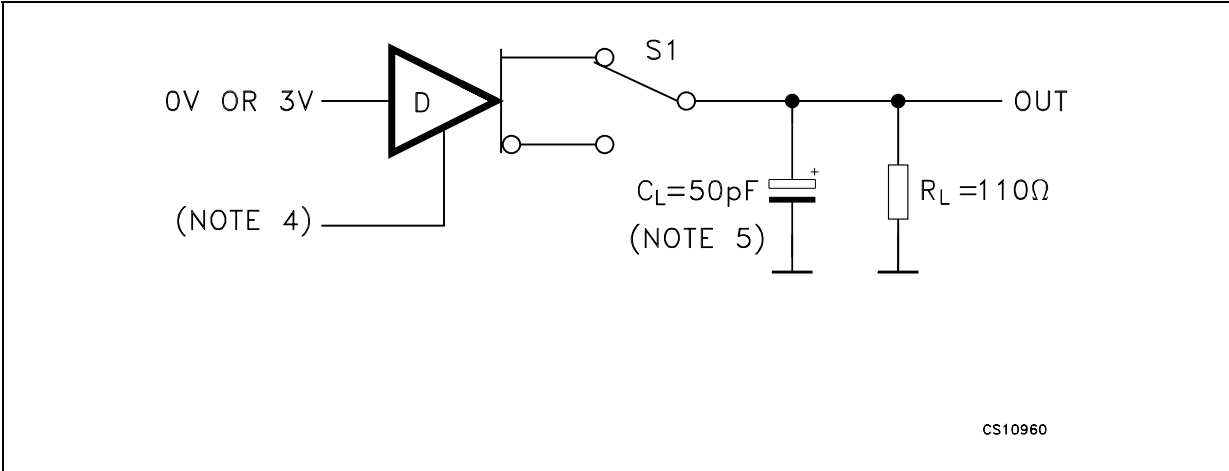

Figure 7 : Drive Enable and Disable Times Waveforms

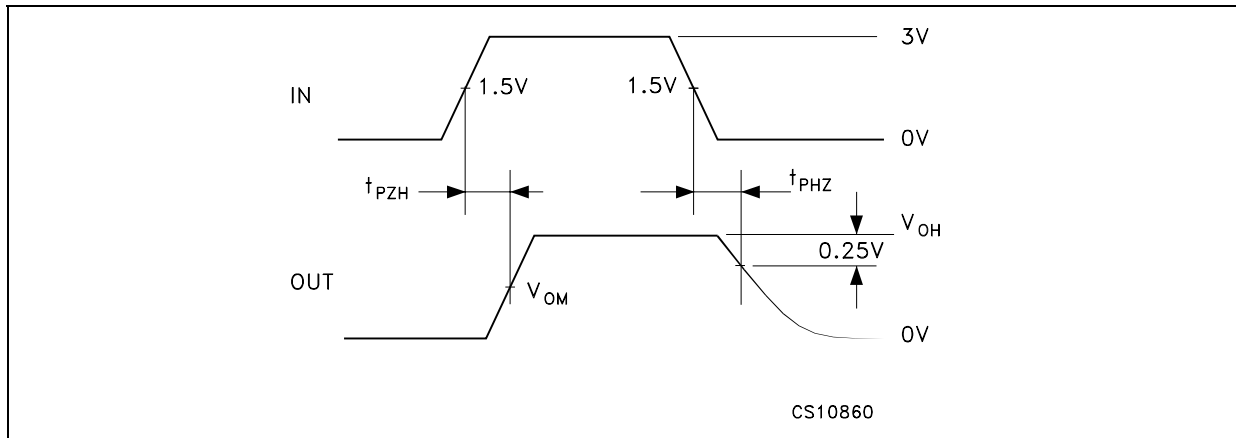

Figure 8 : Drive Propagation Time Test Circuit

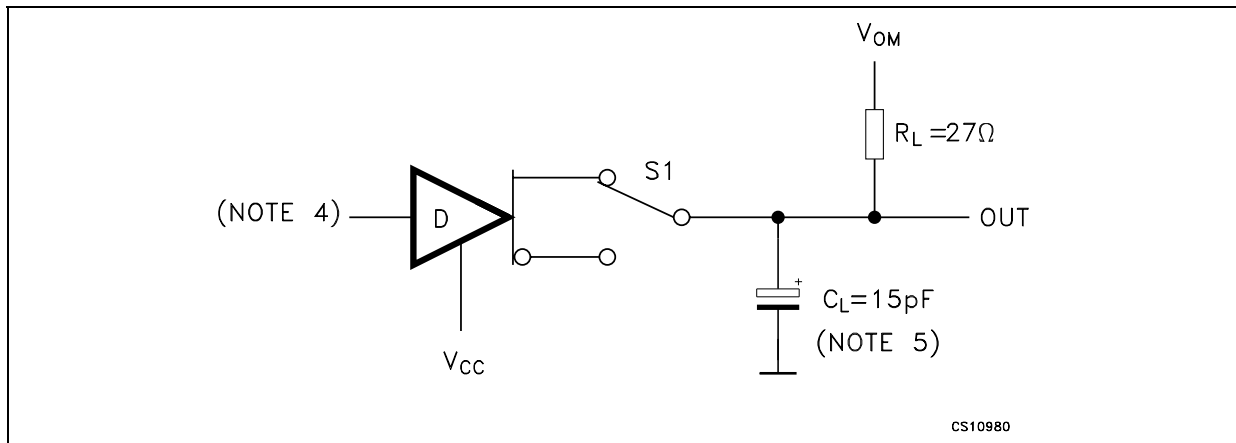

Figure 9 : Drive Propagation Time Waveform

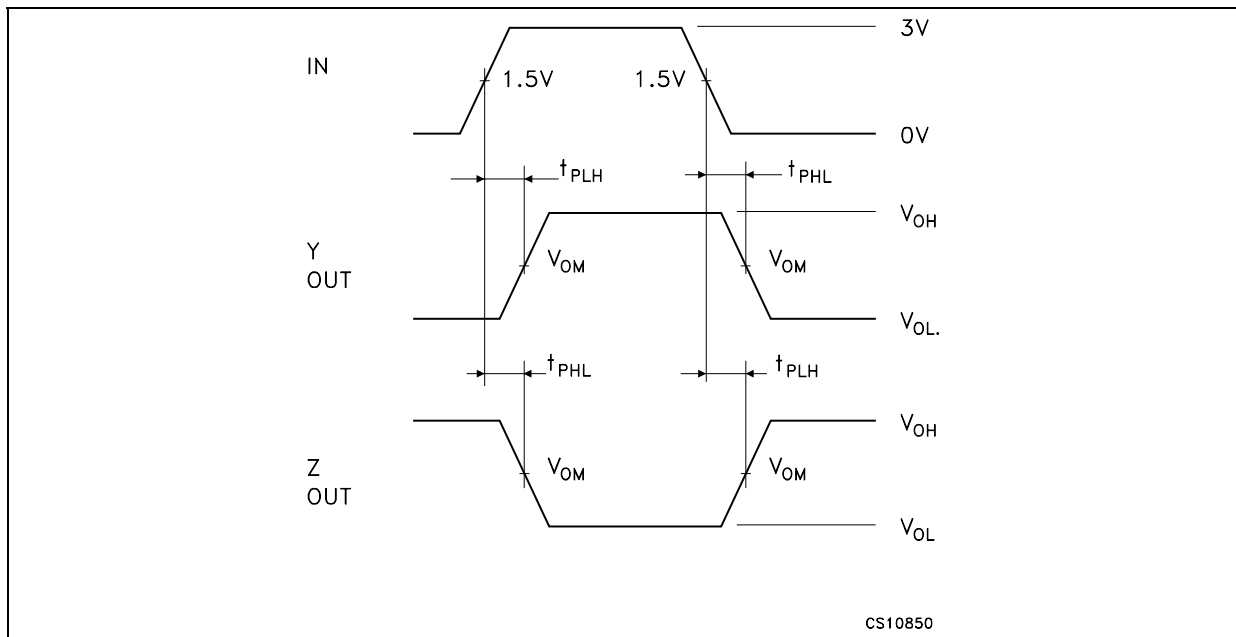



Figure 10 : Drive Enable and Disable Times Test Circuit

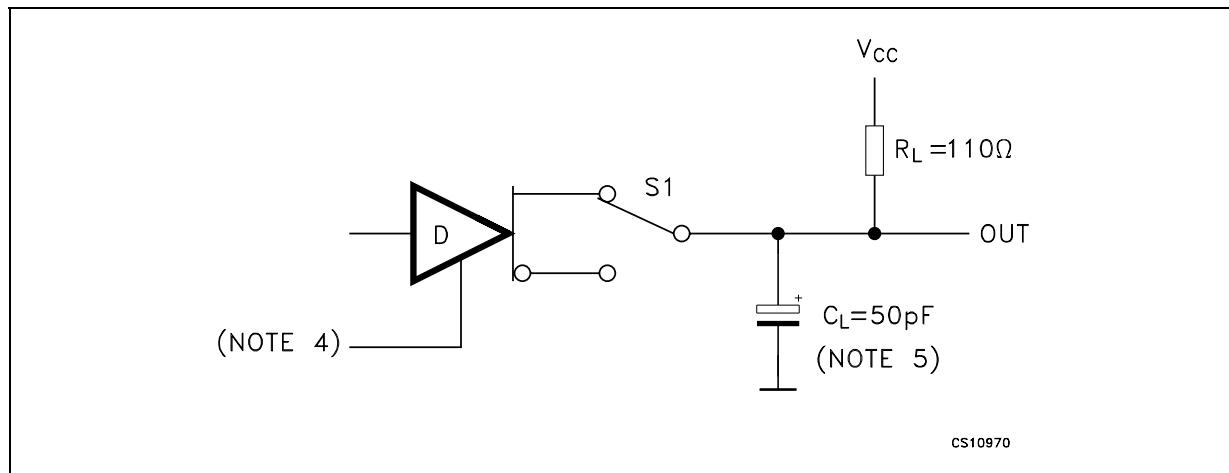

Figure 11 : Drive Enable and Disable Times Waveforms

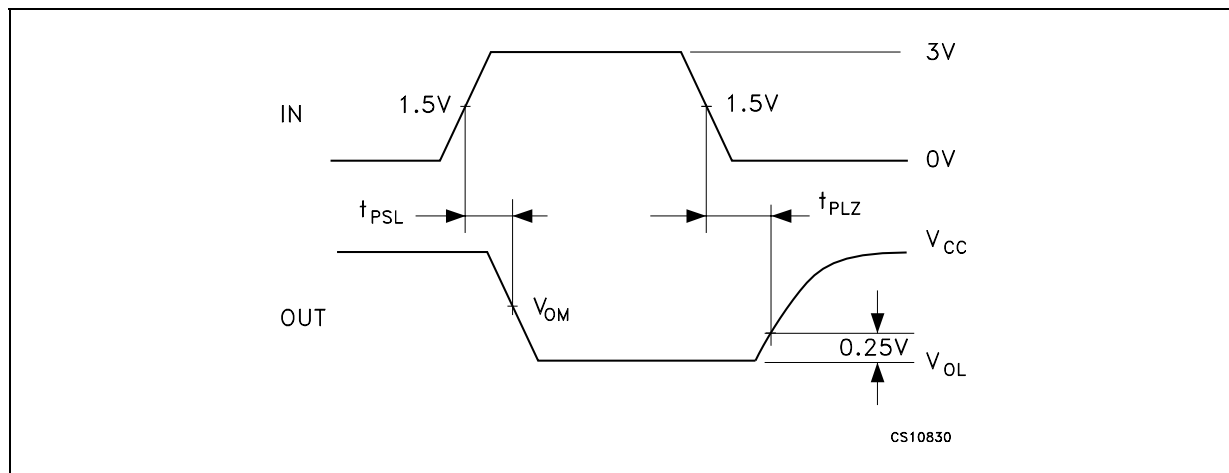

Figure 12 : Receiver Propagation Delay Time Test Circuit

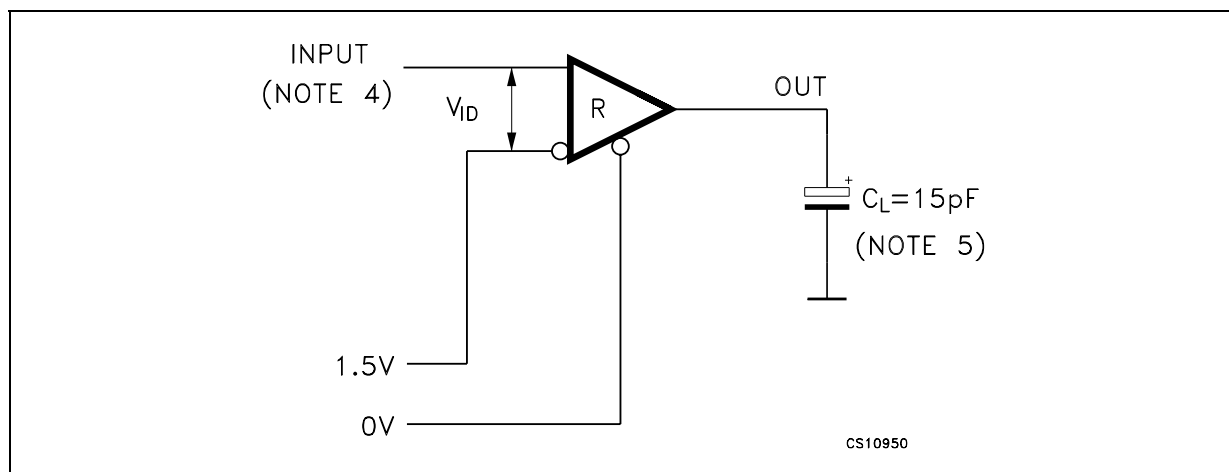

Figure 13 : Receiver Propagation Delay Time Waveforms

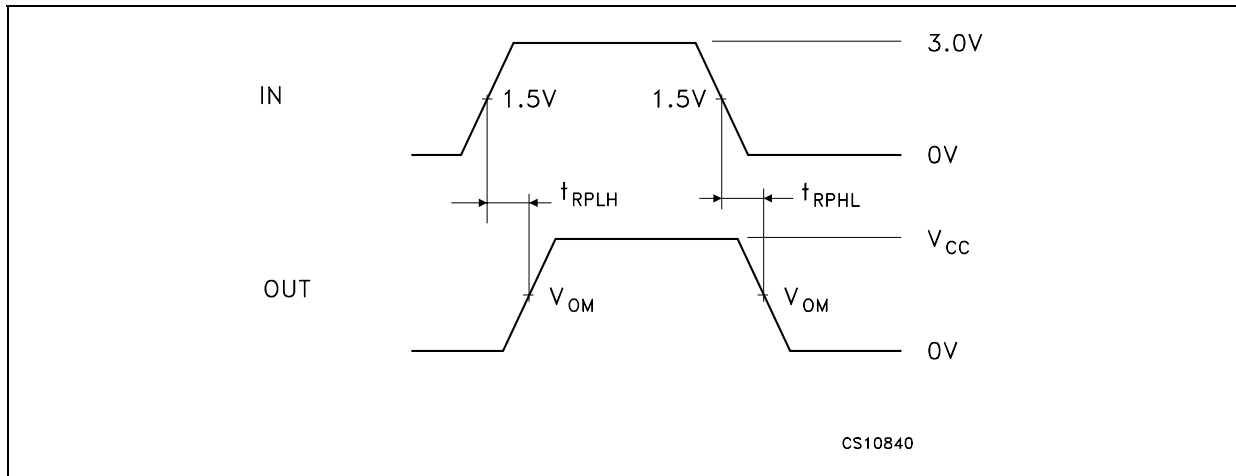

Figure 14 : Receiver Enable and Disable Times Test Circuit

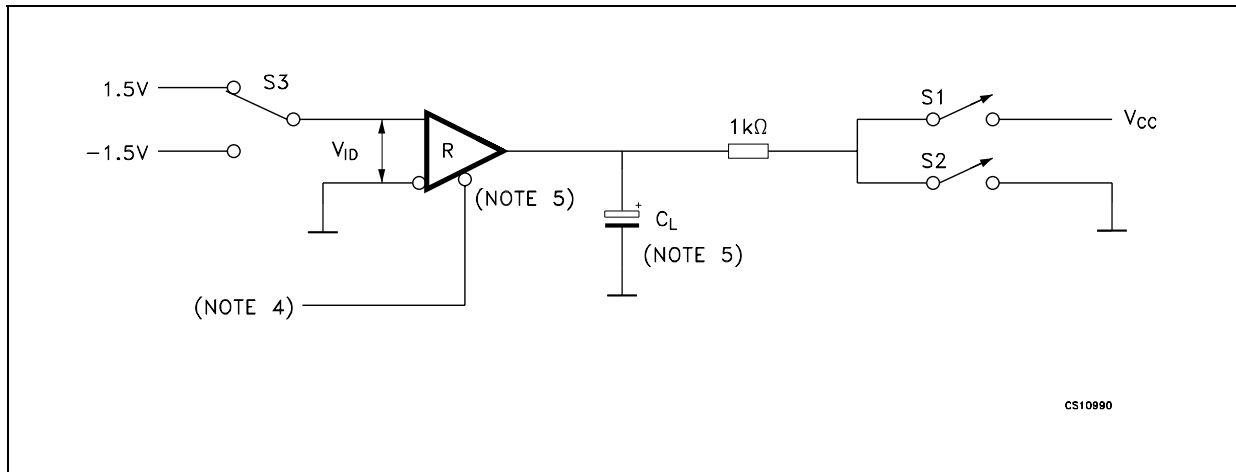

Figure 15 : Receiver Enable and Disable Times Waveform

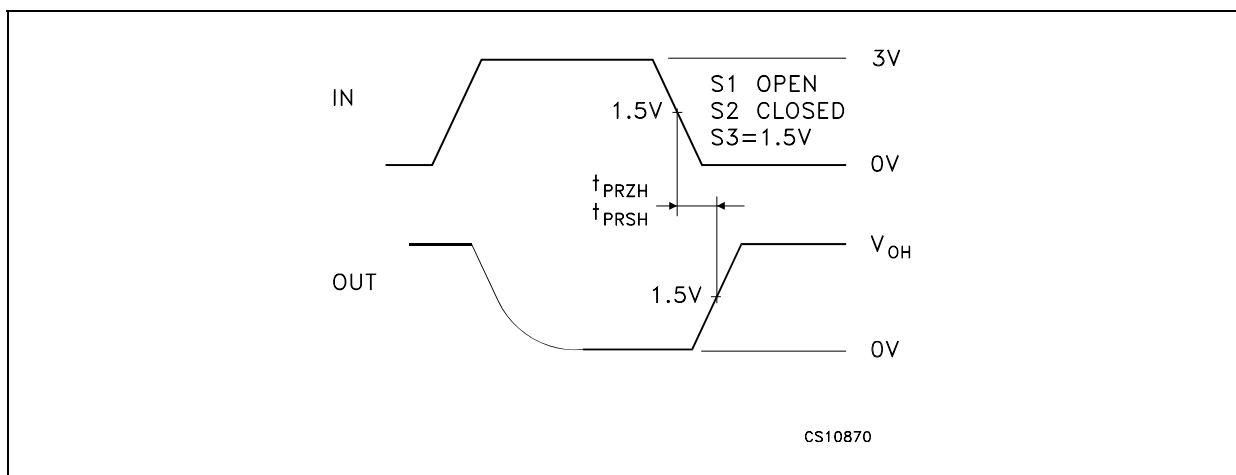

Figure 16 : Receiver Enable and Disable Times Waveform

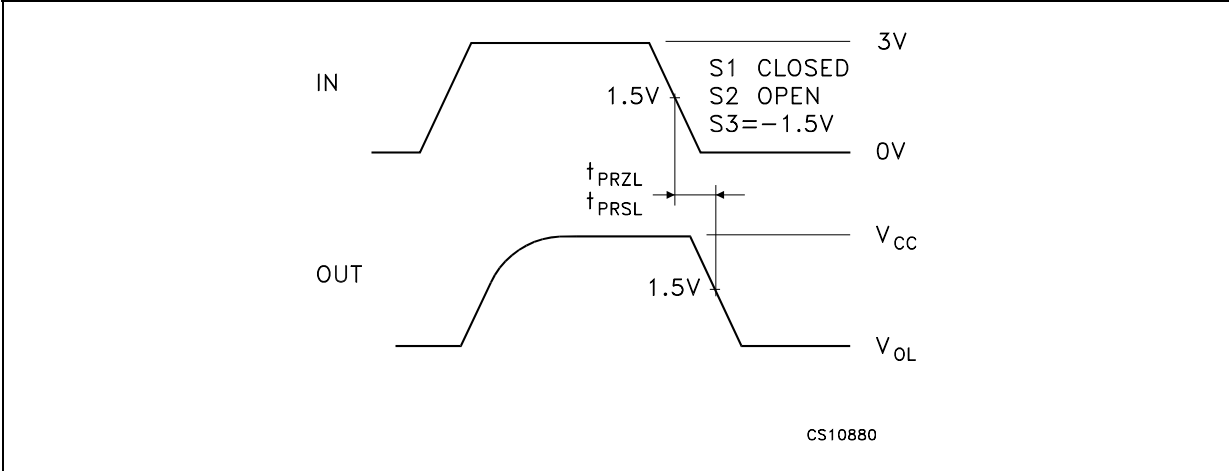

Figure 17 : Receiver Enable and Disable Times Waveform

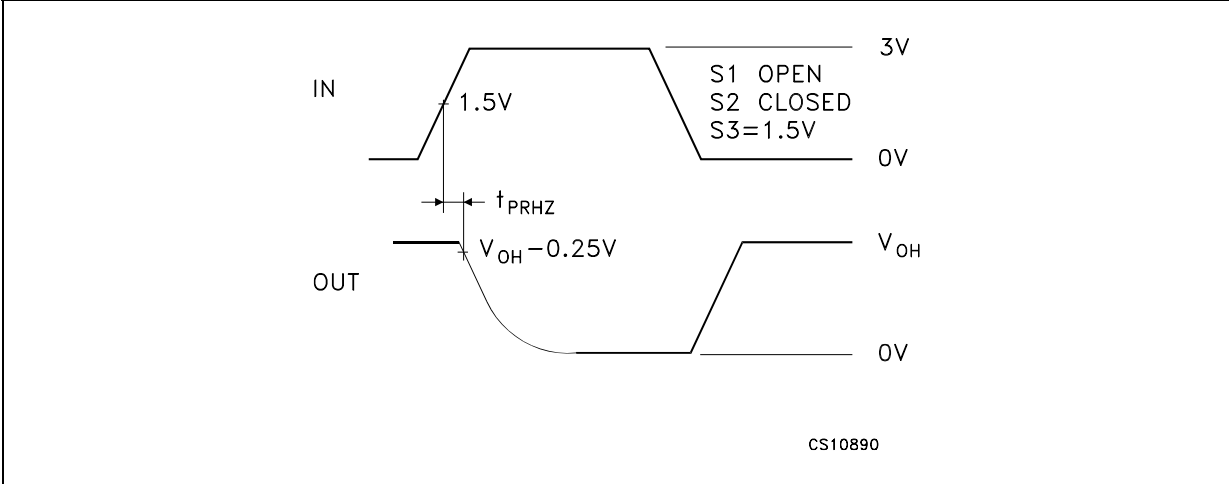
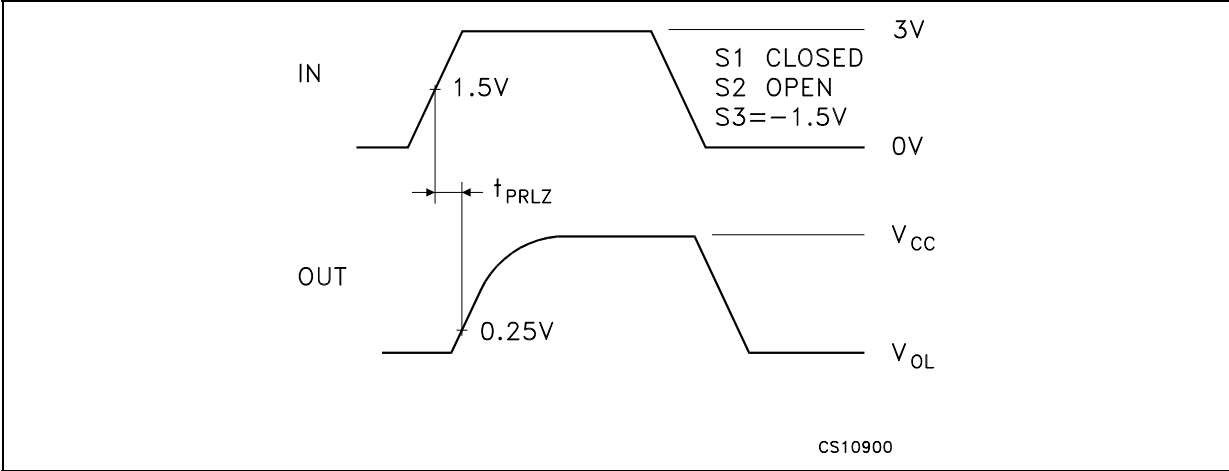
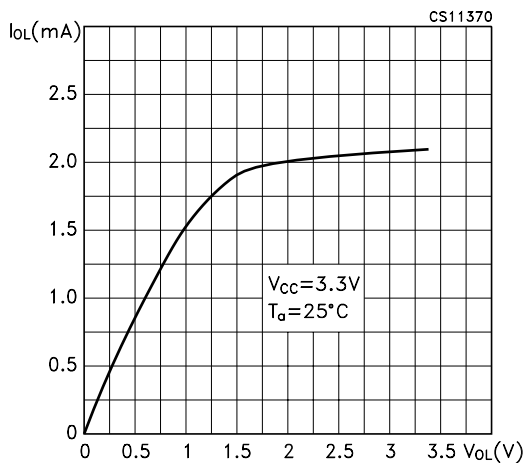

Figure 18 : Receiver Enable and Disable Times Waveform



**Figure 19 : Receiver Output Current vs Output Low Voltage**



**Figure 22 : High Level Driver Output Capability**

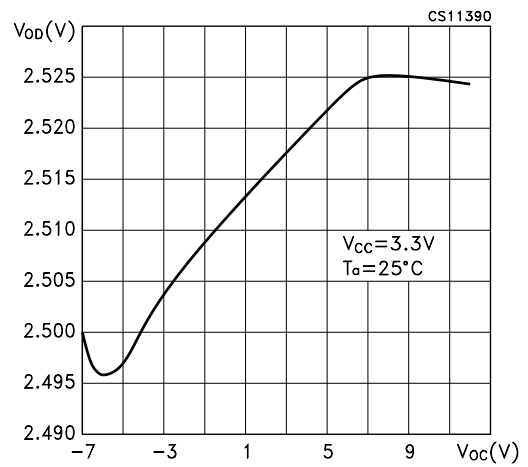

**Figure 20 : Receiver Output Current vs Output High Voltage**

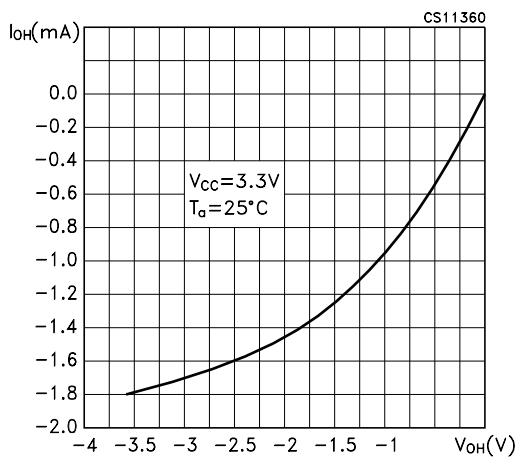

**Figure 23 : Receiver Input Characteristics**

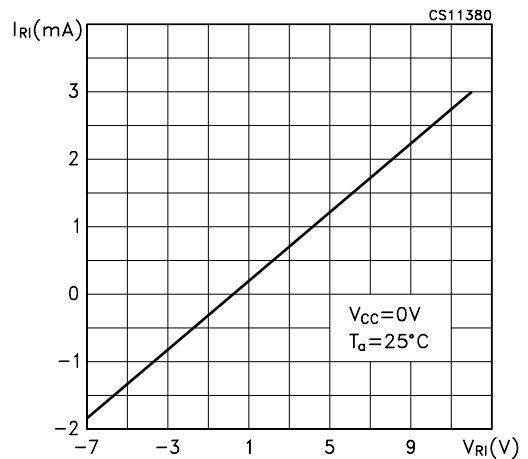

**Figure 21 : Low Level Driver Output Capability**

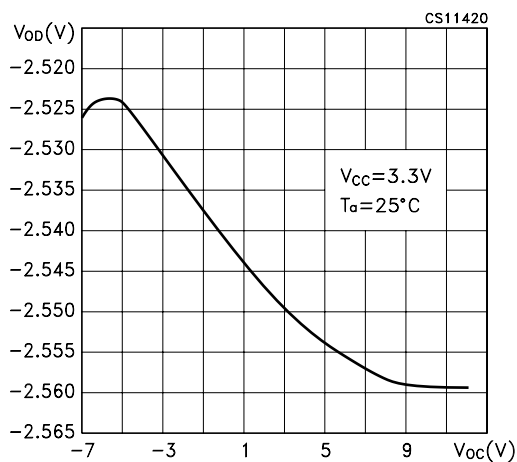

**Figure 24 : Driver Short Circuit Current**

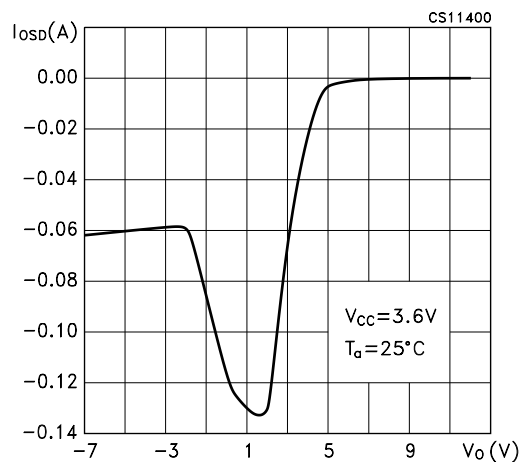
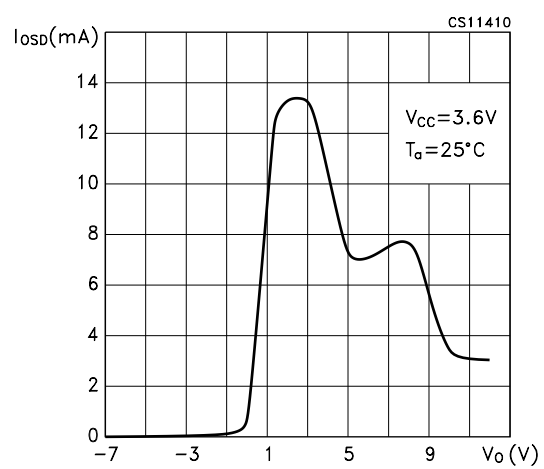
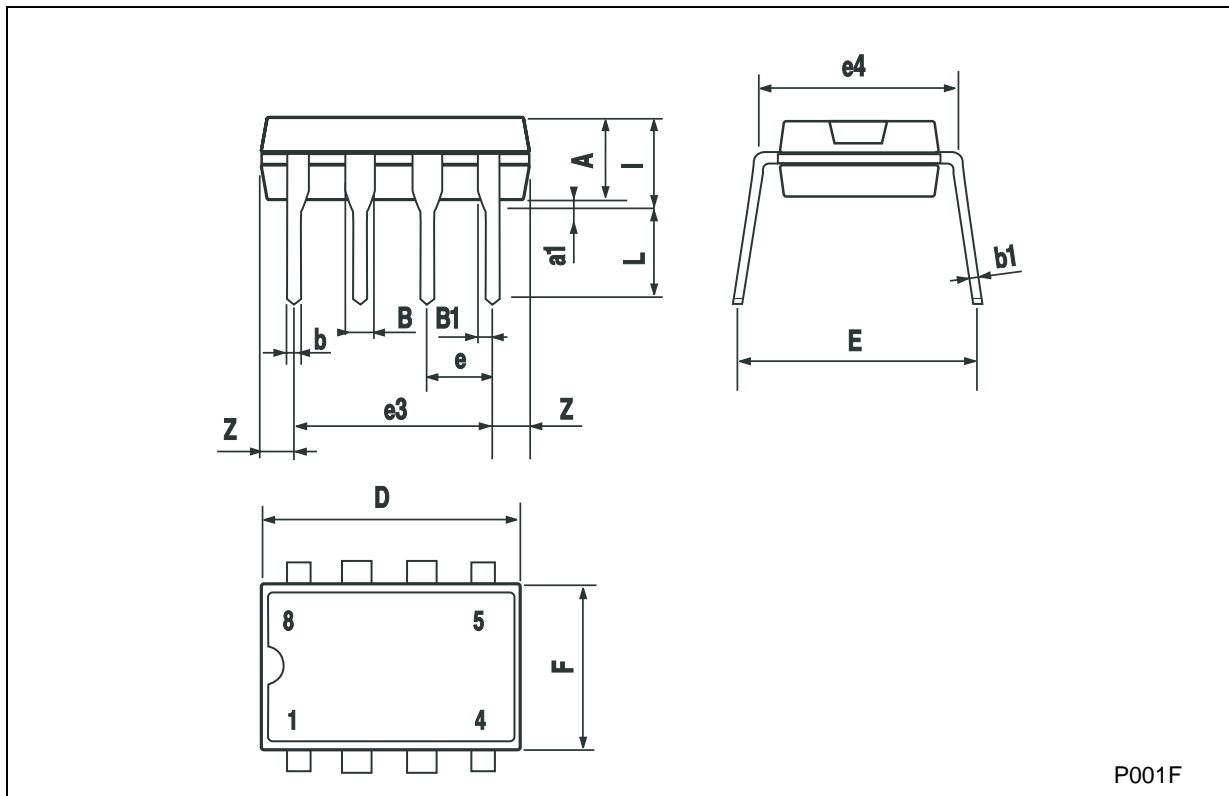

Figure 25 : Driver Short Circuit Current



**Plastic DIP-8 MECHANICAL DATA**

DIM.	mm.			inch		
	MIN.	TYP	MAX.	MIN.	TYP.	MAX.
A		3.3			0.130	
a1	0.7			0.028		
B	1.39		1.65	0.055		0.065
B1	0.91		1.04	0.036		0.041
b		0.5			0.020	
b1	0.38		0.5	0.015		0.020
D			9.8			0.386
E		8.8			0.346	
e		2.54			0.100	
e3		7.62			0.300	
e4		7.62			0.300	
F			7.1			0.280
l			4.8			0.189
L		3.3			0.130	
Z	0.44		1.6	0.017		0.063



P001F

**SO-8 MECHANICAL DATA**

DIM.	mm.			inch		
	MIN.	TYP.	MAX.	MIN.	TYP.	MAX.
A			1.75			0.068
a1	0.1		0.25	0.003		0.009
a2			1.65			0.064
a3	0.65		0.85	0.025		0.033
b	0.35		0.48	0.013		0.018
b1	0.19		0.25	0.007		0.010
C	0.25		0.5	0.010		0.019
c1	45° (typ.)					
D	4.8		5.0	0.189		0.196
E	5.8		6.2	0.228		0.244
e		1.27			0.050	
e3		3.81			0.150	
F	3.8		4.0	0.149		0.157
L	0.4		1.27	0.015		0.050
M			0.6			0.023
S	8° (max.)					

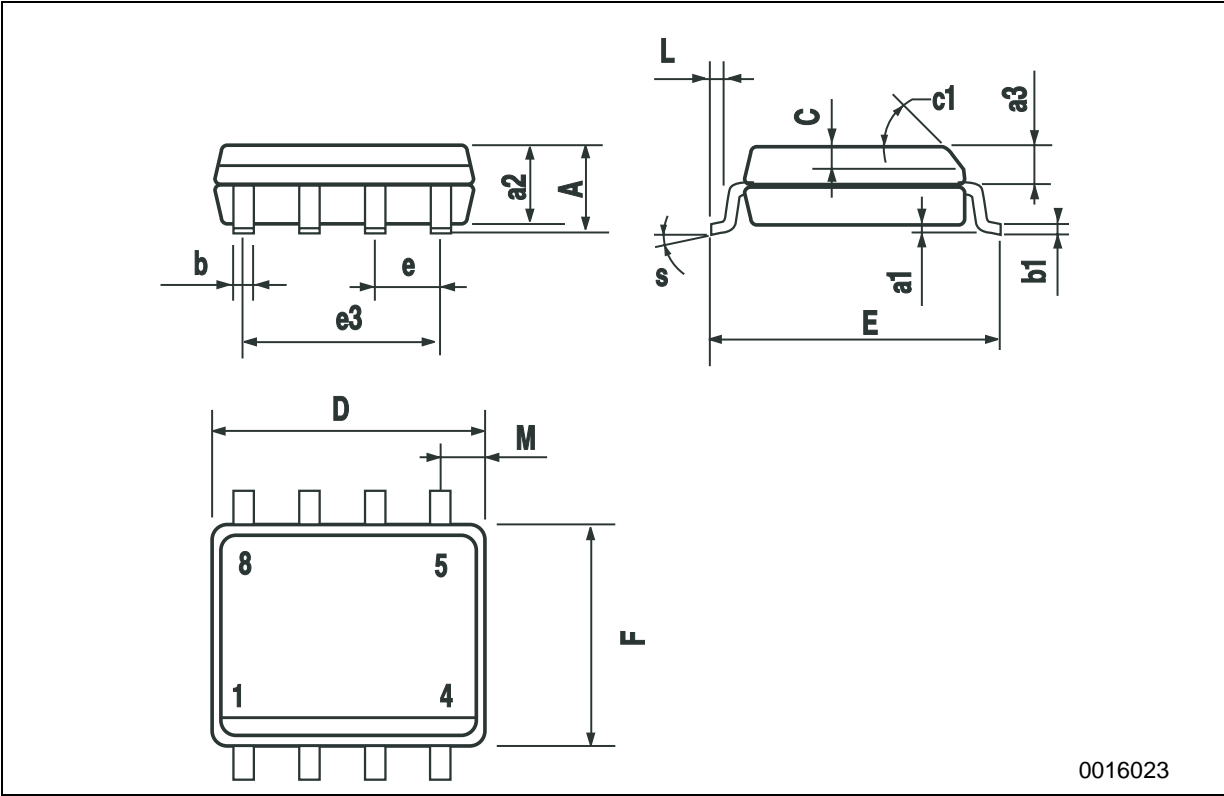

0016023

Information furnished is believed to be accurate and reliable. However, STMicroelectronics assumes no responsibility for the consequences of use of such information nor for any infringement of patents or other rights of third parties which may result from its use. No license is granted by implication or otherwise under any patent or patent rights of STMicroelectronics. Specifications mentioned in this publication are subject to change without notice. This publication supersedes and replaces all information previously supplied. STMicroelectronics products are not authorized for use as critical components in life support devices or systems without express written approval of STMicroelectronics.

© The ST logo is a registered trademark of STMicroelectronics

© 2002 STMicroelectronics - Printed in Italy - All Rights Reserved  
STMicroelectronics GROUP OF COMPANIES

Australia - Brazil - Canada - China - Finland - France - Germany - Hong Kong - India - Israel - Italy - Japan - Malaysia - Malta - Morocco  
Singapore - Spain - Sweden - Switzerland - United Kingdom - United States.

© <http://www.st.com>