

## 8-BIT DUAL-SUPPLY BUS TRANSCEIVER WITH CONFIGURABLE VOLTAGE TRANSLATION AND 3-STATE OUTPUTS

Check for Samples: [SN74AVC8T245-Q1](#)

### FEATURES

- Qualified for Automotive Applications
- Control Inputs  $V_{IH}/V_{IL}$  Levels Are Referenced to  $V_{CCA}$  Voltage
- $V_{CC}$  Isolation Feature – If Either  $V_{CC}$  Input Is at GND, All I/O Ports Are in the High-Impedance State
- $I_{off}$  Supports Partial Power-Down-Mode Operation
- Fully Configurable Dual-Rail Design Allows
  - Each Port to Operate Over the Full 1.4-V to 3.6-V Power-Supply Range
- I/Os Are 4.6-V Tolerant
- Max Data Rates
  - 170 Mbps ( $V_{CCA} < 1.8\text{ V}$  or  $V_{CCB} < 1.8\text{ V}$ )
  - 320 Mbps ( $V_{CCA} \geq 1.8\text{ V}$  and  $V_{CCB} \geq 1.8\text{ V}$ )
- Latch-Up Performance Exceeds 100 mA Per JESD 78, Class II

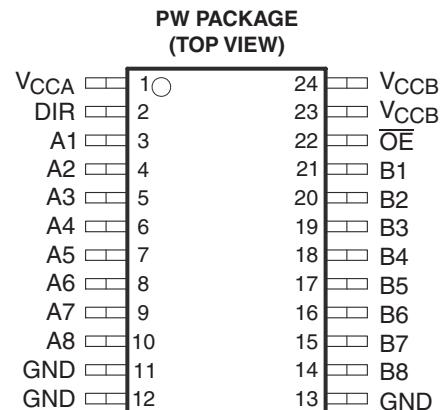
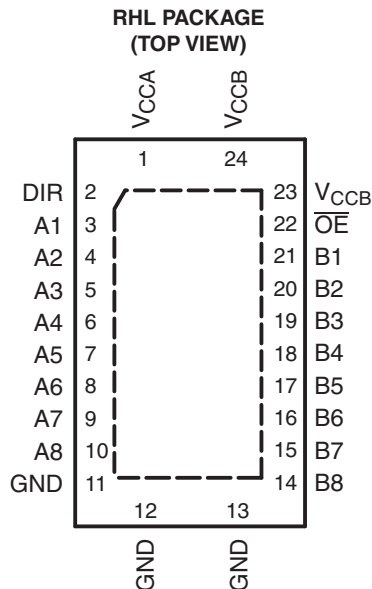

### DESCRIPTION/ORDERING INFORMATION

This 8-bit noninverting bus transceiver uses two separate configurable power-supply rails. The SN74AVC8T245 is optimized to operate with  $V_{CCA}/V_{CCB}$  set at 1.4 V to 3.6 V. It is operational with  $V_{CCA}/V_{CCB}$  as low as 1.2 V. The A port is designed to track  $V_{CCA}$ .  $V_{CCA}$  accepts any supply voltage from 1.2 V to 3.6 V. The B port is designed to track  $V_{CCB}$ .  $V_{CCB}$  accepts any supply voltage from 1.2 V to 3.6 V. This allows for universal low-voltage bidirectional translation between any of the 1.2-V, 1.5-V, 1.8-V, 2.5-V, and 3.3-V voltage nodes.

The SN74AVC8T245 is designed for asynchronous communication between data buses. The device transmits data from the A bus to the B bus or from the B bus to the A bus, depending on the logic level at the direction-control (DIR) input. The output-enable ( $\overline{OE}$ ) input can be used to disable the outputs so the buses are effectively isolated.

The SN74AVC8T245 is designed so the control pins (DIR and  $\overline{OE}$ ) are supplied by  $V_{CCA}$ .

The SN74AVC8T245 solution is compatible with a single-supply system and can be replaced later with a '245 function, with minimal printed circuit board redesign.



Please be aware that an important notice concerning availability, standard warranty, and use in critical applications of Texas Instruments semiconductor products and disclaimers thereto appears at the end of this data sheet.

This device is fully specified for partial-power-down applications using  $I_{off}$ . The  $I_{off}$  circuitry disables the outputs, preventing damaging current backflow through the device when it is powered down.

The  $V_{CC}$  isolation feature ensures that if either  $V_{CC}$  input is at GND, both ports are in the high-impedance state.

To ensure the high-impedance state during power up or power down,  $\overline{OE}$  should be tied to  $V_{CC}$  through a pullup resistor; the minimum value of the resistor is determined by the current-sinking capability of the driver.

**ORDERING INFORMATION<sup>(1)</sup>**

$T_A$	PACKAGE <sup>(2)</sup>		ORDERABLE PART NUMBER	TOP-SIDE MARKING
-40°C to 125°C	QFN – RHL	Reel of 1000	CAVC8T245QRHLRQ1	WE245Q
	TSSOP – PW	Reel of 2000	SN74AVC8T245QPWRQ1	WE245Q

(1) For the most current package and ordering information, see the Package Option Addendum at the end of this document, or see the TI web site at [www.ti.com](http://www.ti.com).

(2) Package drawings, thermal data, and symbolization are available at [www.ti.com/packaging](http://www.ti.com/packaging).

**FUNCTION TABLE  
(each 8-bit section)**

INPUTS		OPERATION
$\overline{OE}$	DIR	
L	L	B data to A bus
L	H	A data to B bus
H	X	All outputs Hi-Z

**LOGIC DIAGRAM (POSITIVE LOGIC)**

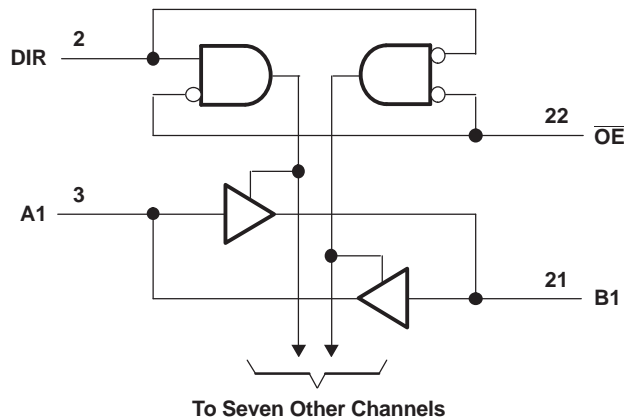

**ABSOLUTE MAXIMUM RATINGS<sup>(1)</sup>**

over operating free-air temperature range (unless otherwise noted)

$V_{CCA}$ $V_{CCB}$	Supply voltage range		–0.5 V to 4.6 V	
$V_I$	Input voltage range <sup>(2)</sup>	I/O ports (A port)	–0.5 V to 4.6 V	
		I/O ports (B port)	–0.5 V to 4.6 V	
		Control inputs	–0.5 V to 4.6 V	
$V_O$	Voltage range applied to any output in the high-impedance or power-off state <sup>(2)</sup>	A port	–0.5 V to 4.6 V	
		B port	–0.5 V to 4.6 V	
$V_O$	Voltage range applied to any output in the high or low state <sup>(2) (3)</sup>	A port	–0.5 V to ( $V_{CCA} + 0.5$ ) V	
		B port	–0.5 V to ( $V_{CCB} + 0.5$ ) V	
$I_{IK}$	Input clamp current	$V_I < 0$	–50 mA	
$I_{OK}$	Output clamp current	$V_O < 0$	–50 mA	
$I_O$	Continuous output current		±50 mA	
	Continuous current through $V_{CCA}$ , $V_{CCB}$ , or GND		±100 mA	
$\theta_{JA}$	Package thermal impedance <sup>(4)</sup>		39.3°C/W	
$T_{stg}$	Storage temperature range		–65°C to 150°C	
ESD	Electrostatic discharge	Human-Body Model (HBM)		8000 V
		Machine Model (MM)		200 V
		Charged-Device Model (CDM)	CAVC8T245QRHLRQ1	1000 V
			SN74AVC8T245QPWRQ1	750 V

- (1) Stresses beyond those listed under "absolute maximum ratings" may cause permanent damage to the device. These are stress ratings only, and functional operation of the device at these or any other conditions beyond those indicated under "recommended operating conditions" is not implied. Exposure to absolute-maximum-rated conditions for extended periods may affect device reliability.
- (2) The input voltage and output negative-voltage ratings may be exceeded if the input and output current ratings are observed.
- (3) The output positive-voltage rating may be exceeded up to 4.6 V maximum if the output current rating is observed.
- (4) The package thermal impedance is calculated in accordance with JESD 51-5.

**RECOMMENDED OPERATING CONDITIONS** (1) (2) (3)

		$V_{CCI}$	$V_{CCO}$	MIN	MAX	UNIT
$V_{CCA}$	Supply voltage			1.2	3.6	V
$V_{CCB}$	Supply voltage			1.2	3.6	V
$V_{IH}$	High-level input voltage	Data inputs	1.2 V to 1.95 V	$V_{CCI} \times 0.65$		V
			1.95 V to 2.7 V	1.6		
			2.7 V to 3.6 V	2		
$V_{IL}$	Low-level input voltage	Data inputs	1.2 V to 1.95 V	$V_{CCI} \times 0.35$		V
			1.95 V to 2.7 V	0.7		
			2.7 V to 3.6 V	0.8		
$V_{IH}$	High-level input voltage	DIR (referenced to $V_{CCA}$ )	1.2 V to 1.95 V	$V_{CCA} \times 0.65$		V
			1.95 V to 2.7 V	1.6		
			2.7 V to 3.6 V	2		
$V_{IL}$	Low-level input voltage	DIR (referenced to $V_{CCA}$ )	1.2 V to 1.95 V	$V_{CCA} \times 0.35$		V
			1.95 V to 2.7 V	0.7		
			2.7 V to 3.6 V	0.8		
$V_I$	Input voltage			0	3.6	V
$V_O$	Output voltage	Active state		0	$V_{CCO}$	V
		3-state		0	3.6	
$I_{OH}$	High-level output current		1.2 V	-3		mA
			1.4 V to 1.6 V	-6		
			1.65 V to 1.95 V	-8		
			2.3 V to 2.7 V	-9		
			3 V to 3.6 V	-12		
$I_{OL}$	Low-level output current		1.2 V	3		mA
			1.4 V to 1.6 V	6		
			1.65 V to 1.95 V	8		
			2.3 V to 2.7 V	9		
			3 V to 3.6 V	12		
$\Delta t/\Delta v$	Input transition rise or fall rate				5	ns/V
$T_A$	Operating free-air temperature			-40	125	°C

(1)  $V_{CCI}$  is the  $V_{CC}$  associated with the input port.

(2)  $V_{CCO}$  is the  $V_{CC}$  associated with the output port.

(3) All unused data inputs of the device must be held at  $V_{CCI}$  or GND to ensure proper device operation. See the TI application report, *Implications of Slow or Floating CMOS Inputs*, literature number [SCBA004](#).

**ELECTRICAL CHARACTERISTICS<sup>(1) (2)</sup>**

over recommended operating free-air temperature range (unless otherwise noted)

PARAMETER	TEST CONDITIONS	V <sub>CCA</sub>	V <sub>CCB</sub>	T <sub>A</sub> = 25°C			–40°C to 125°C		UNIT
				MIN	TYP	MAX	MIN	MAX	
V <sub>OH</sub>	I <sub>OH</sub> = –100 μA	V <sub>I</sub> = V <sub>IH</sub>	1.2 V to 3.6 V	1.2 V to 3.6 V			V <sub>CCO</sub> – 0.2	V	
	I <sub>OH</sub> = –3 mA		1.2 V	1.2 V	0.95				
	I <sub>OH</sub> = –6 mA		1.4 V	1.4 V		1.00			
	I <sub>OH</sub> = –8 mA		1.65 V	1.65 V		1.2			
	I <sub>OH</sub> = –9 mA		2.3 V	2.3 V		1.75			
	I <sub>OH</sub> = –12 mA		3 V	3 V		2.3			
V <sub>OL</sub>	I <sub>OL</sub> = 100 μA	V <sub>I</sub> = V <sub>IL</sub>	1.2 V to 3.6 V	1.2 V to 3.6 V			0.2	V	
	I <sub>OL</sub> = 3 mA		1.2 V	1.2 V	0.15				
	I <sub>OL</sub> = 6 mA		1.4 V	1.4 V		0.35			
	I <sub>OL</sub> = 8 mA		1.65 V	1.65 V		0.45			
	I <sub>OL</sub> = 9 mA		2.3 V	2.3 V		0.55			
	I <sub>OL</sub> = 12 mA		3 V	3 V		0.7			
I <sub>i</sub>	Control inputs	V <sub>I</sub> = V <sub>CCA</sub> or GND	1.2 V to 3.6 V	1.2 V to 3.6 V	±0.025	±0.25	±1	μA	
I <sub>off</sub>	A or B port	V <sub>I</sub> or V <sub>O</sub> = 0 to 3.6 V	0 V	0 V to 3.6 V	±0.1	±1	±5	μA	
			0 V to 3.6 V	0 V	±0.1	±1	±5		
I <sub>OZ</sub> <sup>(3)</sup>	A or B port	V <sub>O</sub> = V <sub>CCO</sub> or GND, V <sub>I</sub> = V <sub>CCI</sub> or GND, OE = V <sub>IH</sub>	3.6 V	3.6 V	±0.5	±2.5	±5	μA	
I <sub>CCA</sub>		V <sub>I</sub> = V <sub>CCI</sub> or GND <sup>(4)</sup> , I <sub>O</sub> = 0	1.2 V to 3.6 V	1.2 V to 3.6 V			15	μA	
			0 V	3.6 V			–2		
			3.6 V	0 V			15		
I <sub>CCB</sub>		V <sub>I</sub> = V <sub>CCI</sub> or GND <sup>(4)</sup> , I <sub>O</sub> = 0	1.2 V to 3.6 V	1.2 V to 3.6 V			15	μA	
			0 V	3.6 V			15		
			3.6 V	0 V			–2		
I <sub>CCA</sub> + I <sub>CCB</sub>		V <sub>I</sub> = V <sub>CCI</sub> or GND, I <sub>O</sub> = 0	1.2 V to 3.6 V	1.2 V to 3.6 V			25	μA	
C <sub>i</sub>	Control inputs	V <sub>I</sub> = 3.3 V or GND	3.3 V	3.3 V	3.5			pF	
C <sub>io</sub>	A or B port	V <sub>O</sub> = 3.3 V or GND	3.3 V	3.3 V	6			pF	

(1) V<sub>CCO</sub> is the V<sub>CC</sub> associated with the output port.

(2) V<sub>CCI</sub> is the V<sub>CC</sub> associated with the input port.

(3) For I/O ports, the parameter I<sub>OZ</sub> includes the input leakage current.

(4) All unused data inputs of the device must be held at V<sub>CCI</sub> or GND to ensure proper device operation. See the TI application report, *Implications of Slow or Floating CMOS Inputs*, literature number [SCBA004](#).

## SWITCHING CHARACTERISTICS

over recommended operating free-air temperature range,  $V_{CCA} = 1.2\text{ V}$  (see [Figure 10](#))

PARAMETER	FROM (INPUT)	TO (OUTPUT)	$V_{CCB} = 1.2\text{ V}$	$V_{CCB} = 1.5\text{ V}$	$V_{CCB} = 1.8\text{ V}$	$V_{CCB} = 2.5\text{ V}$	$V_{CCB} = 3.3\text{ V}$	UNIT
			TYP	TYP	TYP	TYP	TYP	
$t_{PLH}$	A	B	3.1	2.6	2.5	3	3.5	ns
$t_{PHL}$			3.1	2.6	2.5	3	3.5	
$t_{PLH}$	B	A	3.1	2.7	2.5	2.4	2.3	ns
$t_{PHL}$			3.1	2.7	2.5	2.4	2.3	
$t_{PZH}$	$\overline{OE}$	A	5.3	5.3	5.3	5.3	5.3	ns
$t_{PZL}$			5.3	5.3	5.3	5.3	5.3	
$t_{PZH}$	$\overline{OE}$	B	5.1	4	3.5	3.2	3.1	ns
$t_{PZL}$			5.1	4	3.5	3.2	3.1	
$t_{PHZ}$	$\overline{OE}$	A	4.8	4.8	4.8	4.8	4.8	ns
$t_{PLZ}$			4.8	4.8	4.8	4.8	4.8	
$t_{PHZ}$	$\overline{OE}$	B	4.7	4	4.1	4.3	5.1	ns
$t_{PLZ}$			4.7	4	4.1	4.3	5.1	

## SWITCHING CHARACTERISTICS

over recommended operating free-air temperature range,  $V_{CCA} = 1.5\text{ V} \pm 0.1\text{ V}$  (see [Figure 10](#))

PARAMETER	FROM (INPUT)	TO (OUTPUT)	$V_{CCB} = 1.2\text{ V}$	$V_{CCB} = 1.5\text{ V} \pm 0.1\text{ V}$		$V_{CCB} = 1.8\text{ V} \pm 0.15\text{ V}$		$V_{CCB} = 2.5\text{ V} \pm 0.2\text{ V}$		$V_{CCB} = 3.3\text{ V} \pm 0.3\text{ V}$		UNIT
			TYP	MIN	MAX	MIN	MAX	MIN	MAX	MIN	MAX	
$t_{PLH}$	A	B	2.7	0.5	14.7	0.5	13.3	0.5	13.9	0.5	17.2	ns
$t_{PHL}$			2.7	0.5	14.7	0.5	13.3	0.5	13.9	0.5	17.2	
$t_{PLH}$	B	A	2.6	0.5	14.7	0.5	14.2	0.5	13.5	0.5	13.2	ns
$t_{PHL}$			2.6	0.5	14.7	0.5	14.2	0.5	13.5	0.5	13.2	
$t_{PZH}$	$\overline{OE}$	A	3.7	0.5	20.5	0.5	20.5	0.5	20.5	0.5	20.5	ns
$t_{PZL}$			3.7	0.5	20.5	0.5	20.5	0.5	20.5	0.5	20.5	
$t_{PZH}$	$\overline{OE}$	B	4.8	0.5	18.6	0.5	17.7	0.5	15.1	0.5	14.4	ns
$t_{PZL}$			4.8	0.5	18.6	0.5	17.7	0.5	15.1	0.5	14.4	
$t_{PHZ}$	$\overline{OE}$	A	3.1	0.5	20.3	0.5	20.3	0.5	20.3	0.5	20.3	ns
$t_{PLZ}$			3.1	0.5	20.3	0.5	20.3	0.5	20.3	0.5	20.3	
$t_{PHZ}$	$\overline{OE}$	B	4.1	0.5	20.0	0.5	18.6	0.5	17.9	0.5	18.9	ns
$t_{PLZ}$			4.1	0.5	20.0	0.5	18.6	0.5	17.9	0.5	18.9	

## SWITCHING CHARACTERISTICS

 over recommended operating free-air temperature range,  $V_{CCA} = 1.8\text{ V} \pm 0.15\text{ V}$  (see [Figure 10](#))

PARAMETER	FROM (INPUT)	TO (OUTPUT)	$V_{CCB} = 1.2\text{ V}$	$V_{CCB} = 1.5\text{ V} \pm 0.1\text{ V}$		$V_{CCB} = 1.8\text{ V} \pm 0.15\text{ V}$		$V_{CCB} = 2.5\text{ V} \pm 0.2\text{ V}$		$V_{CCB} = 3.3\text{ V} \pm 0.3\text{ V}$		UNIT
			TYP	MIN	MAX	MIN	MAX	MIN	MAX	MIN	MAX	
$t_{PLH}$	A	B	2.5	0.5	14.2	0.5	13.0	0.5	12.3	0.5	12.1	ns
$t_{PHL}$			2.5	0.5	14.2	0.5	13.0	0.5	12.3	0.5	12.1	
$t_{PLH}$	B	A	2.5	0.5	13.3	0.5	13.0	0.5	12.1	0.5	11.8	ns
$t_{PHL}$			2.5	0.5	13.3	0.5	13.0	0.5	12.1	0.5	11.8	
$t_{PZH}$	$\overline{OE}$	A	3	0.5	17.2	0.5	17.2	0.5	17.2	0.5	17.2	ns
$t_{PZL}$			3	0.5	17.2	0.5	17.2	0.5	17.2	0.5	17.2	
$t_{PZH}$	$\overline{OE}$	B	4.6	0.5	19.6	0.5	17.0	0.5	14.2	0.5	13.2	ns
$t_{PZL}$			4.6	0.5	19.6	0.5	17.0	0.5	14.2	0.5	13.2	
$t_{PHZ}$	$\overline{OE}$	A	2.8	0.5	17.7	0.5	17.7	0.5	17.7	0.5	17.7	ns
$t_{PLZ}$			2.8	0.5	17.7	0.5	17.7	0.5	17.7	0.5	17.7	
$t_{PHZ}$	$\overline{OE}$	B	3.9	0.5	18.9	0.5	17.3	0.5	15.8	0.5	15.4	ns
$t_{PLZ}$			3.9	0.5	18.9	0.5	17.3	0.5	15.8	0.5	15.4	

## SWITCHING CHARACTERISTICS

 over recommended operating free-air temperature range,  $V_{CCA} = 2.5\text{ V} \pm 0.2\text{ V}$  (see [Figure 10](#))

PARAMETER	FROM (INPUT)	TO (OUTPUT)	$V_{CCB} = 1.2\text{ V}$	$V_{CCB} = 1.5\text{ V} \pm 0.1\text{ V}$		$V_{CCB} = 1.8\text{ V} \pm 0.15\text{ V}$		$V_{CCB} = 2.5\text{ V} \pm 0.2\text{ V}$		$V_{CCB} = 3.3\text{ V} \pm 0.3\text{ V}$		UNIT
			TYP	MIN	MAX	MIN	MAX	MIN	MAX	MIN	MAX	
$t_{PLH}$	A	B	2.4	0.5	13.5	0.5	12.1	0.5	10.7	0.5	10.2	ns
$t_{PHL}$			2.4	0.5	13.5	0.5	12.1	0.5	10.7	0.5	10.2	
$t_{PLH}$	B	A	3	0.5	13.9	0.5	12.3	0.5	10.7	0.5	10.4	ns
$t_{PHL}$			3	0.5	13.9	0.5	12.3	0.5	10.7	0.5	10.4	
$t_{PZH}$	$\overline{OE}$	A	2.2	0.5	13.7	0.5	13.7	0.5	13.7	0.5	13.7	ns
$t_{PZL}$			2.2	0.5	13.7	0.5	13.7	0.5	13.7	0.5	13.7	
$t_{PZH}$	$\overline{OE}$	B	4.5	0.5	19.1	0.5	16.5	0.5	13.3	0.5	12.3	ns
$t_{PZL}$			4.5	0.5	19.1	0.5	16.5	0.5	13.3	0.5	12.3	
$t_{PHZ}$	$\overline{OE}$	A	1.8	0.5	14.2	0.5	14.2	0.5	14.2	0.5	14.2	ns
$t_{PLZ}$			1.8	0.5	14.2	0.5	14.2	0.5	14.2	0.5	14.2	
$t_{PHZ}$	$\overline{OE}$	B	3.6	0.5	17.7	0.5	16.3	0.5	14.2	0.5	12.1	ns
$t_{PLZ}$			3.6	0.5	17.7	0.5	16.3	0.5	14.2	0.5	12.1	

### SWITCHING CHARACTERISTICS

over recommended operating free-air temperature range,  $V_{CCA} = 3.3\text{ V} \pm 0.3\text{ V}$  (see Figure 10)

PARAMETER	FROM (INPUT)	TO (OUTPUT)	$V_{CCB} = 1.2\text{ V}$	$V_{CCB} = 1.5\text{ V} \pm 0.1\text{ V}$		$V_{CCB} = 1.8\text{ V} \pm 0.15\text{ V}$		$V_{CCB} = 2.5\text{ V} \pm 0.2\text{ V}$		$V_{CCB} = 3.3\text{ V} \pm 0.3\text{ V}$		UNIT
			TYP	MIN	MAX	MIN	MAX	MIN	MAX	MIN	MAX	
$t_{PLH}$	A	B	2.3	0.5	13.2	0.5	11.1	0.5	10.4	0.5	9.7	ns
$t_{PHL}$			2.3	0.5	13.2	0.5	11.1	0.5	10.4	0.5	9.7	
$t_{PLH}$	B	A	3.5	0.5	17.2	0.5	12.1	0.5	10.2	0.5	9.7	ns
$t_{PHL}$			3.5	0.5	17.2	0.5	12.1	0.5	10.2	0.5	9.7	
$t_{PZH}$	$\overline{OE}$	A	2	0.5	12.3	0.5	12.3	0.5	12.3	0.5	12.3	ns
$t_{PZL}$			2	0.5	12.3	0.5	12.3	0.5	12.3	0.5	12.3	
$t_{PZH}$	$\overline{OE}$	B	4.5	0.5	18.9	0.5	16.1	0.5	13.2	0.5	12.1	ns
$t_{PZL}$			4.5	0.5	18.9	0.5	16.1	0.5	13.2	0.5	12.1	
$t_{PHZ}$	$\overline{OE}$	A	1.7	0.5	12.3	0.5	12.3	0.5	12.3	0.5	12.3	ns
$t_{PLZ}$			1.7	0.5	12.3	0.5	12.3	0.5	12.3	0.5	12.3	
$t_{PHZ}$	$\overline{OE}$	B	3.4	0.5	17.4	0.5	15.8	0.5	13.7	0.5	12.6	ns
$t_{PLZ}$			3.4	0.5	17.4	0.5	15.8	0.5	13.7	0.5	12.6	

### OPERATING CHARACTERISTICS

$T_A = 25^\circ\text{C}$

PARAMETER			TEST CONDITIONS	$V_{CCA} = V_{CCB} = 1.2\text{ V}$	$V_{CCA} = V_{CCB} = 1.5\text{ V}$	$V_{CCA} = V_{CCB} = 1.8\text{ V}$	$V_{CCA} = V_{CCB} = 2.5\text{ V}$	$V_{CCA} = V_{CCB} = 3.3\text{ V}$	UNIT
				TYP	TYP	TYP	TYP	TYP	
$C_{pdA}$ (1)	A to B	Outputs enabled	$C_L = 0,$ $f = 10\text{ MHz},$ $t_r = t_f = 1\text{ ns}$	1	1	1	1	1	pF
		Outputs disabled		1	1	1	1	1	
	B to A	Outputs enabled		12	12	12	13	14	
		Outputs disabled		1	1	1	1	1	
$C_{pdB}$ (1)	A to B	Outputs enabled	$C_L = 0,$ $f = 10\text{ MHz},$ $t_r = t_f = 1\text{ ns}$	12	12	12	13	14	pF
		Outputs disabled		1	1	1	1	1	
	B to A	Outputs enabled		1	1	1	1	1	
		Outputs disabled		1	1	1	1	1	

(1) Power dissipation capacitance per transceiver

**Table 1. Typical Total Static Power Consumption ( $I_{CCA} + I_{CCB}$ )**

$V_{CCB}$	$V_{CCA}$						UNIT
	0 V	1.2 V	1.5 V	1.8 V	2.5 V	3.3 V	
0 V	0	<0.5	<0.5	<0.5	<0.5	<0.5	$\mu\text{A}$
1.2 V	<0.5	<1	<1	<1	<1	1	
1.5 V	<0.5	<1	<1	<1	<1	1	
1.8 V	<0.5	<1	<1	<1	<1	<1	
2.5 V	<0.5	1	<1	<1	<1	<1	
3.3 V	<0.5	1	<1	<1	<1	<1	



TYPICAL CHARACTERISTICS

Typical Propagation Delay (A to B) vs Load Capacitance  
 $T_A = 25^\circ\text{C}$ ,  $V_{CCA} = 1.2\text{ V}$

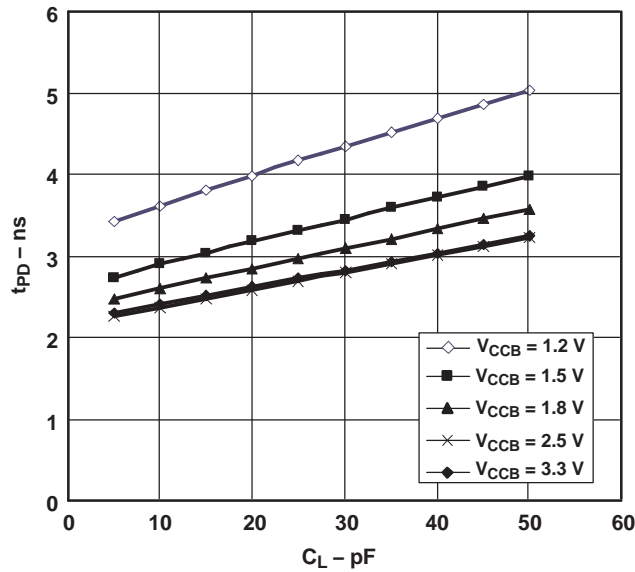

Figure 1.

Typical Propagation Delay (A to B) vs Load Capacitance  
 $T_A = 25^\circ\text{C}$ ,  $V_{CCA} = 1.5\text{ V}$

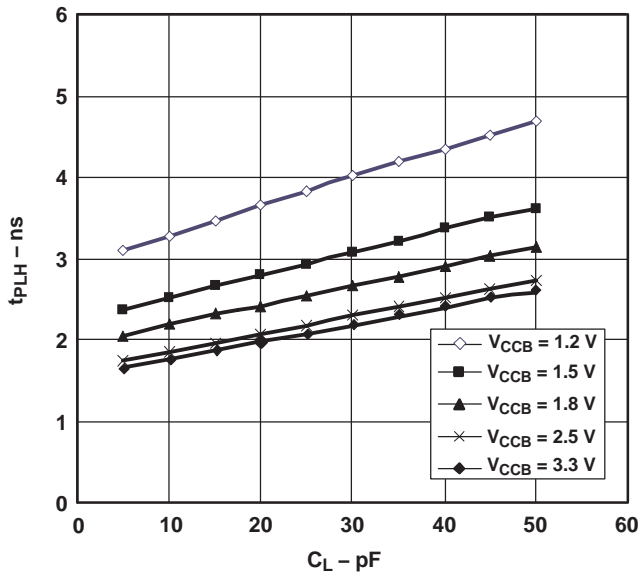

Figure 2.

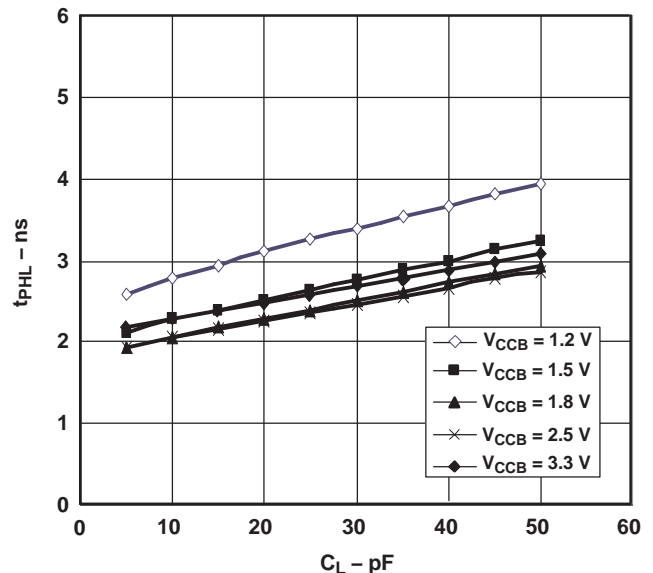

Figure 3.

TYPICAL CHARACTERISTICS (continued)

Typical Propagation Delay (A to B) vs Load Capacitance  
 $T_A = 25^\circ\text{C}$ ,  $V_{CCA} = 1.8\text{ V}$

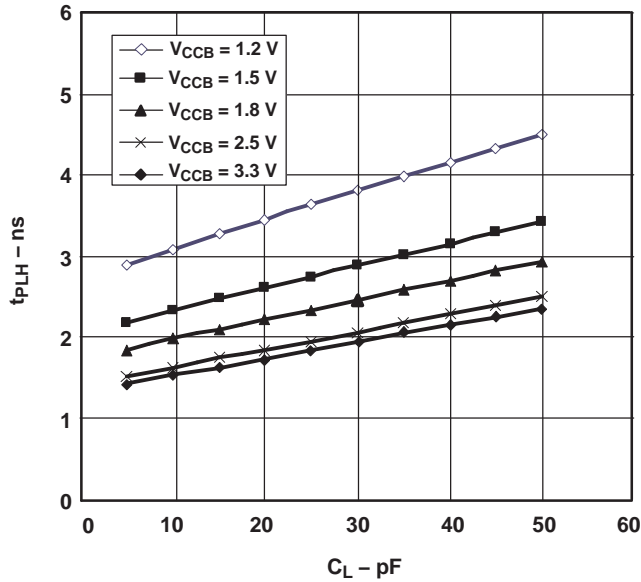

Figure 4.

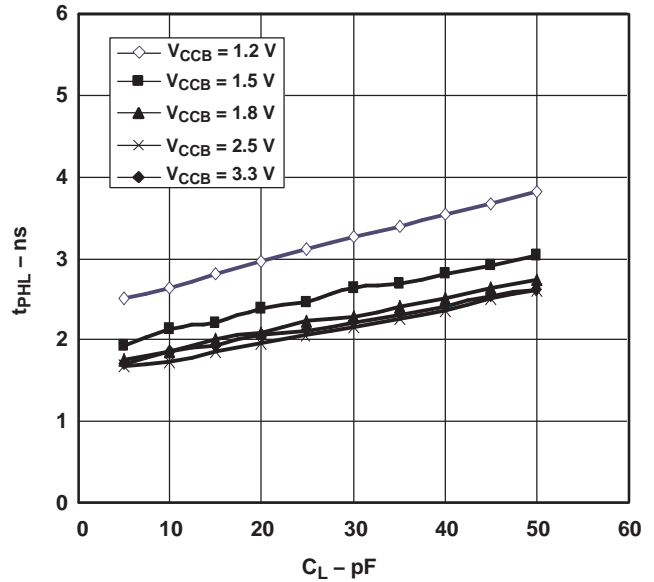

Figure 5.

Typical Propagation Delay (A to B) vs Load Capacitance  
 $T_A = 25^\circ\text{C}$ ,  $V_{CCA} = 2.5\text{ V}$

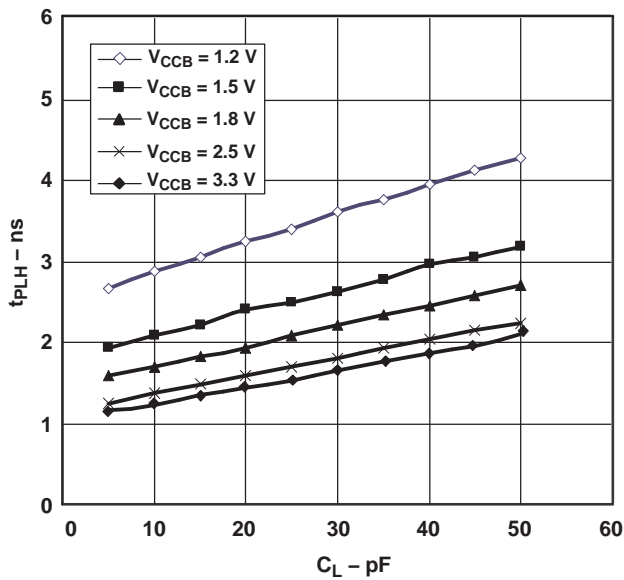

Figure 6.

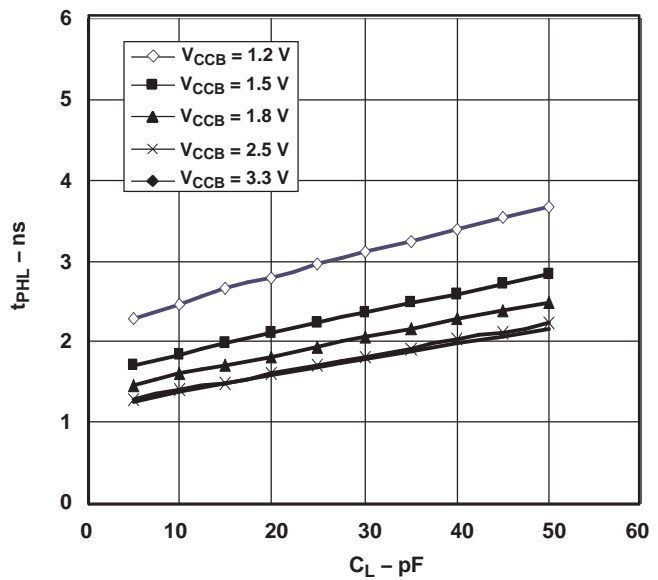

Figure 7.

TYPICAL CHARACTERISTICS (continued)

Typical Propagation Delay (A to B) vs Load Capacitance  
 $T_A = 25^\circ\text{C}$ ,  $V_{CCA} = 3.3\text{ V}$

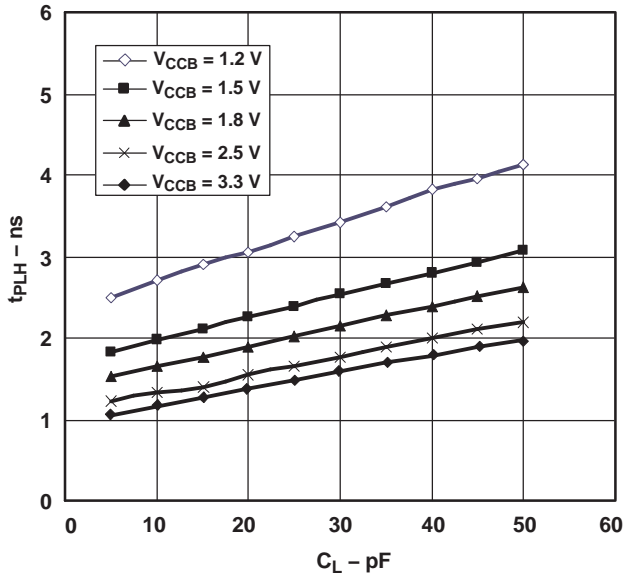

Figure 8.

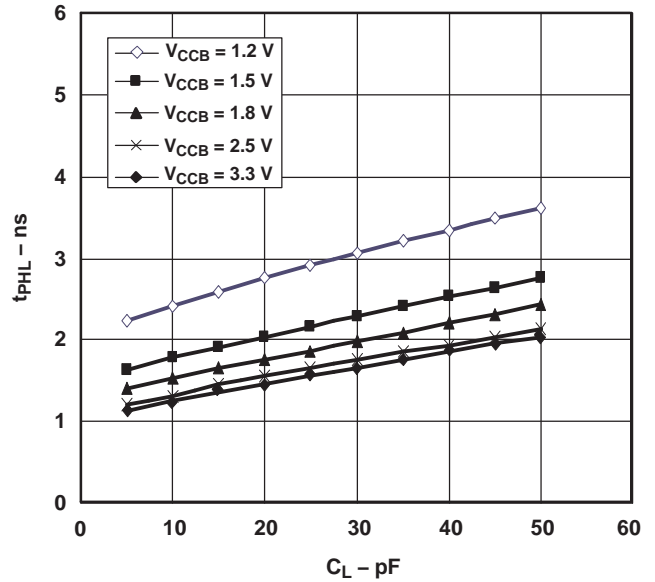
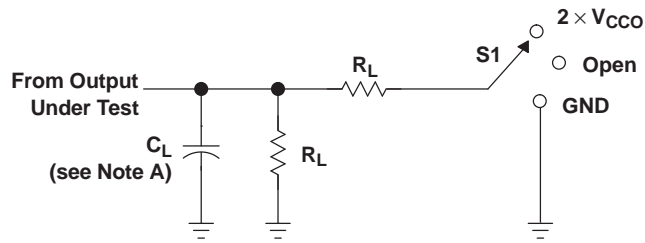

Figure 9.

PARAMETER MEASUREMENT INFORMATION



LOAD CIRCUIT

TEST	S1
$t_{pd}$	Open
$t_{PLZ}/t_{PZL}$	$2 \times V_{CCO}$
$t_{PHZ}/t_{PZH}$	GND

$V_{CCO}$	$C_L$	$R_L$	$V_{TP}$
1.2 V	15 pF	2 k $\Omega$	0.1 V
1.5 V $\pm$ 0.1 V	15 pF	2 k $\Omega$	0.1 V
1.8 V $\pm$ 0.15 V	15 pF	2 k $\Omega$	0.15 V
2.5 V $\pm$ 0.2 V	15 pF	2 k $\Omega$	0.15 V
3.3 V $\pm$ 0.3 V	15 pF	2 k $\Omega$	0.3 V

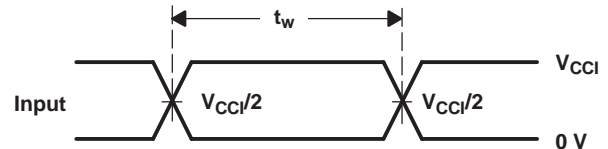

VOLTAGE WAVEFORMS PULSE DURATION

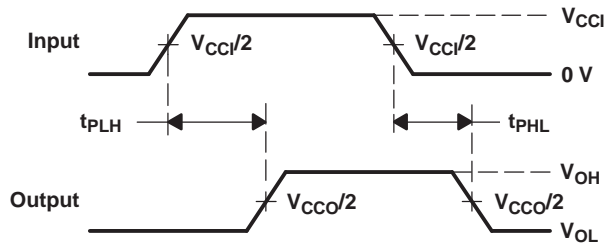

VOLTAGE WAVEFORMS PROPAGATION DELAY TIMES

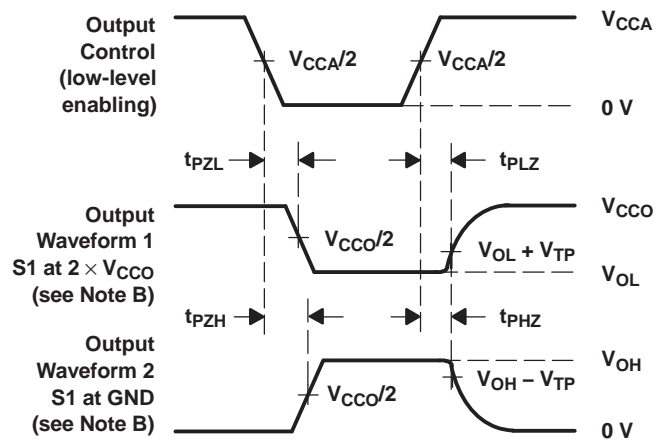

VOLTAGE WAVEFORMS ENABLE AND DISABLE TIMES

- NOTES:
- A.  $C_L$  includes probe and jig capacitance.
  - B. Waveform 1 is for an output with internal conditions such that the output is low, except when disabled by the output control. Waveform 2 is for an output with internal conditions such that the output is high, except when disabled by the output control.
  - C. All input pulses are supplied by generators having the following characteristics:  $PRR \leq 10$  MHz,  $Z_O = 50 \Omega$ ,  $dv/dt \geq 1$  V/ns.
  - D. The outputs are measured one at a time, with one transition per measurement.
  - E.  $t_{PLZ}$  and  $t_{PHZ}$  are the same as  $t_{dis}$ .
  - F.  $t_{PZL}$  and  $t_{PZH}$  are the same as  $t_{en}$ .
  - G.  $t_{PLH}$  and  $t_{PHL}$  are the same as  $t_{pd}$ .
  - H.  $V_{CCI}$  is the  $V_{CC}$  associated with the input port.
  - I.  $V_{CCO}$  is the  $V_{CC}$  associated with the output port.

Figure 10. Load Circuit and Voltage Waveforms

**PACKAGING INFORMATION**

Orderable Device	Status <sup>(1)</sup>	Package Type	Package Drawing	Pins	Package Qty	Eco Plan <sup>(2)</sup>	Lead/ Ball Finish	MSL Peak Temp <sup>(3)</sup>	Samples (Requires Login)
CAVC8T245QRHLRQ1	ACTIVE	QFN	RHL	24	1000	Green (RoHS & no Sb/Br)	CU NIPDAU	Level-2-260C-1 YEAR	
SN74AVC8T245QPWRQ1	ACTIVE	TSSOP	PW	24	2000	Green (RoHS & no Sb/Br)	CU NIPDAU	Level-3-260C-168 HR	

<sup>(1)</sup> The marketing status values are defined as follows:

**ACTIVE:** Product device recommended for new designs.

**LIFEBUY:** TI has announced that the device will be discontinued, and a lifetime-buy period is in effect.

**NRND:** Not recommended for new designs. Device is in production to support existing customers, but TI does not recommend using this part in a new design.

**PREVIEW:** Device has been announced but is not in production. Samples may or may not be available.

**OBsolete:** TI has discontinued the production of the device.

<sup>(2)</sup> Eco Plan - The planned eco-friendly classification: Pb-Free (RoHS), Pb-Free (RoHS Exempt), or Green (RoHS & no Sb/Br) - please check <http://www.ti.com/productcontent> for the latest availability information and additional product content details.

**TBD:** The Pb-Free/Green conversion plan has not been defined.

**Pb-Free (RoHS):** TI's terms "Lead-Free" or "Pb-Free" mean semiconductor products that are compatible with the current RoHS requirements for all 6 substances, including the requirement that lead not exceed 0.1% by weight in homogeneous materials. Where designed to be soldered at high temperatures, TI Pb-Free products are suitable for use in specified lead-free processes.

**Pb-Free (RoHS Exempt):** This component has a RoHS exemption for either 1) lead-based flip-chip solder bumps used between the die and package, or 2) lead-based die adhesive used between the die and leadframe. The component is otherwise considered Pb-Free (RoHS compatible) as defined above.

**Green (RoHS & no Sb/Br):** TI defines "Green" to mean Pb-Free (RoHS compatible), and free of Bromine (Br) and Antimony (Sb) based flame retardants (Br or Sb do not exceed 0.1% by weight in homogeneous material)

<sup>(3)</sup> MSL, Peak Temp. -- The Moisture Sensitivity Level rating according to the JEDEC industry standard classifications, and peak solder temperature.

**Important Information and Disclaimer:** The information provided on this page represents TI's knowledge and belief as of the date that it is provided. TI bases its knowledge and belief on information provided by third parties, and makes no representation or warranty as to the accuracy of such information. Efforts are underway to better integrate information from third parties. TI has taken and continues to take reasonable steps to provide representative and accurate information but may not have conducted destructive testing or chemical analysis on incoming materials and chemicals. TI and TI suppliers consider certain information to be proprietary, and thus CAS numbers and other limited information may not be available for release.

In no event shall TI's liability arising out of such information exceed the total purchase price of the TI part(s) at issue in this document sold by TI to Customer on an annual basis.

**OTHER QUALIFIED VERSIONS OF SN74AVC8T245-Q1 :**

- Catalog: [SN74AVC8T245](#)

NOTE: Qualified Version Definitions:

- Catalog - TI's standard catalog product

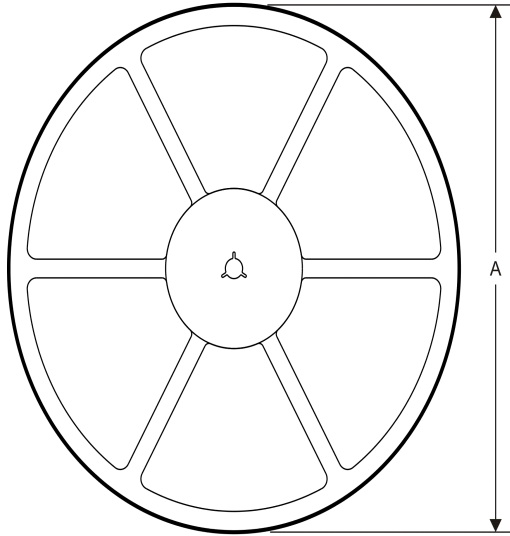
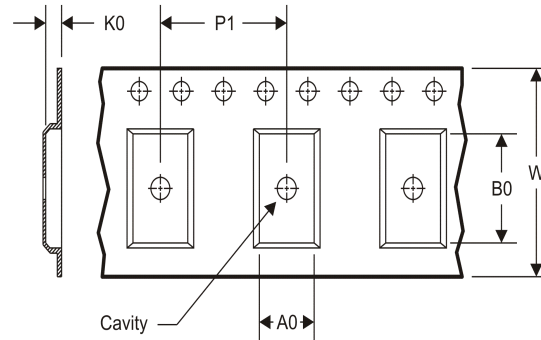
**TAPE AND REEL INFORMATION**
**REEL DIMENSIONS**

**TAPE DIMENSIONS**

A0	Dimension designed to accommodate the component width
B0	Dimension designed to accommodate the component length
K0	Dimension designed to accommodate the component thickness
W	Overall width of the carrier tape
P1	Pitch between successive cavity centers

**TAPE AND REEL INFORMATION**

\*All dimensions are nominal

Device	Package Type	Package Drawing	Pins	SPQ	Reel Diameter (mm)	Reel Width W1 (mm)	A0 (mm)	B0 (mm)	K0 (mm)	P1 (mm)	W (mm)	Pin1 Quadrant
CAVC8T245QRHLRQ1	QFN	RHL	24	1000	180.0	12.4	3.8	5.8	1.2	8.0	12.0	Q1
SN74AVC8T245QPWRQ1	TSSOP	PW	24	2000	330.0	16.4	6.95	8.3	1.6	8.0	16.0	Q1

**TAPE AND REEL BOX DIMENSIONS**

\*All dimensions are nominal

Device	Package Type	Package Drawing	Pins	SPQ	Length (mm)	Width (mm)	Height (mm)
CAVC8T245QRHLRQ1	QFN	RHL	24	1000	210.0	185.0	35.0
SN74AVC8T245QPWRQ1	TSSOP	PW	24	2000	367.0	367.0	38.0



# MECHANICAL DATA

PW (R-PDSO-G24)

PLASTIC SMALL OUTLINE



4040064-6/G 02/11

- NOTES:
- A. All linear dimensions are in millimeters. Dimensioning and tolerancing per ASME Y14.5M-1994.
  - B. This drawing is subject to change without notice.
  -  Body length does not include mold flash, protrusions, or gate burrs. Mold flash, protrusions, or gate burrs shall not exceed 0,15 each side.
  -  Body width does not include interlead flash. Interlead flash shall not exceed 0,25 each side.
  - E. Falls within JEDEC MO-153

PW (R-PDSO-G24)

PLASTIC SMALL OUTLINE

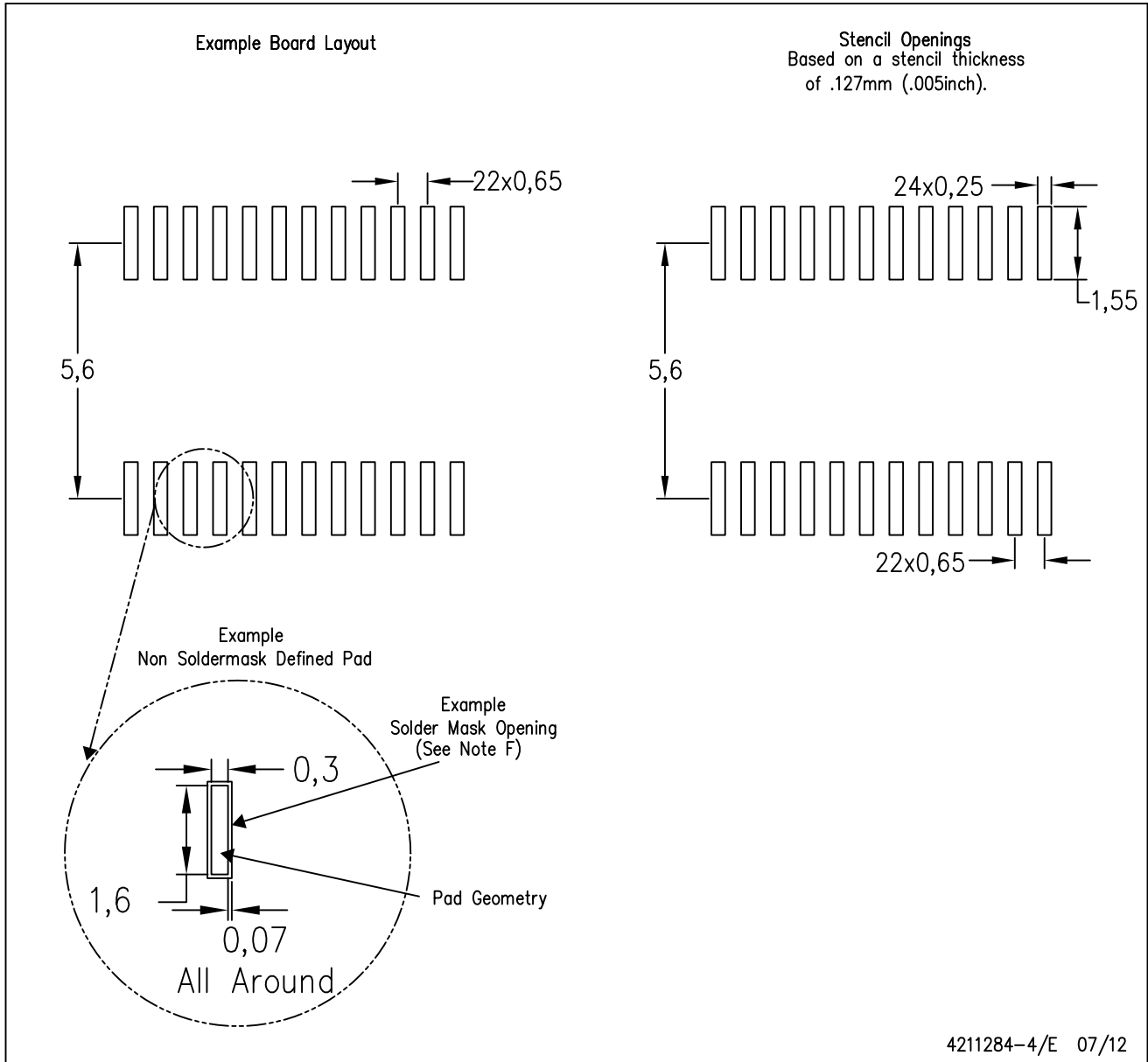

4211284-4/E 07/12

- NOTES:
- A. All linear dimensions are in millimeters.
  - B. This drawing is subject to change without notice.
  - C. Publication IPC-7351 is recommended for alternate design.
  - D. Laser cutting apertures with trapezoidal walls and also rounding corners will offer better paste release. Customers should contact their board assembly site for stencil design recommendations. Refer to IPC-7525 for other stencil recommendations.
  - E. Customers should contact their board fabrication site for solder mask tolerances between and around signal pads.

# MECHANICAL DATA

RHL (R-PVQFN-N24)

PLASTIC QUAD FLATPACK NO-LEAD

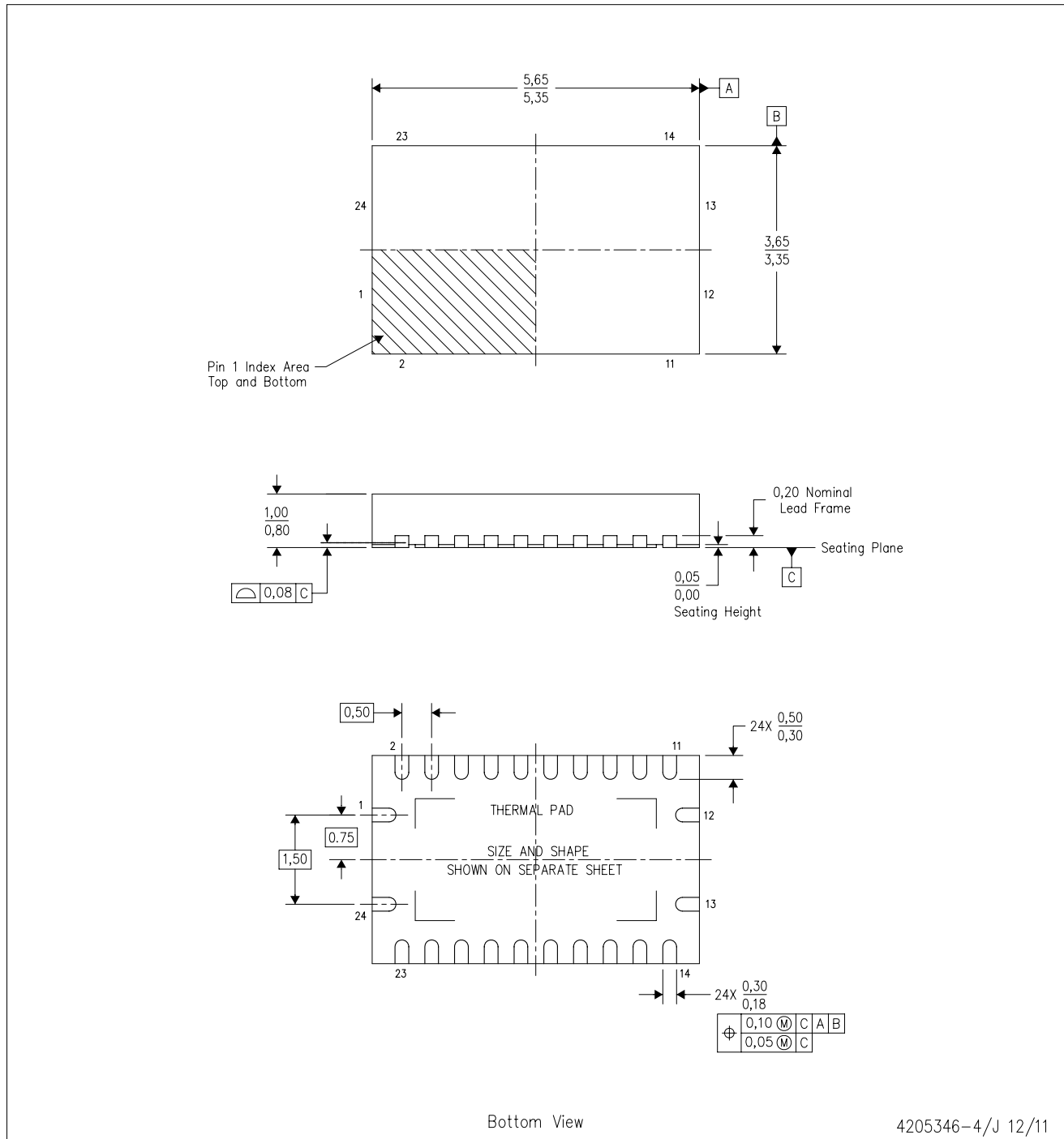

- NOTES:
- All linear dimensions are in millimeters. Dimensioning and tolerancing per ASME Y14.5M-1994.
  - This drawing is subject to change without notice.
  - QFN (Quad Flatpack No-Lead) package configuration.
  - The package thermal pad must be soldered to the board for thermal and mechanical performance.
  - See the additional figure in the Product Data Sheet for details regarding the exposed thermal pad features and dimensions.
  - JEDEC MO-241 package registration pending.

## THERMAL PAD MECHANICAL DATA

RHL (S-PVQFN-N24)

PLASTIC QUAD FLATPACK NO-LEAD

### THERMAL INFORMATION

This package incorporates an exposed thermal pad that is designed to be attached directly to an external heatsink. The thermal pad must be soldered directly to the printed circuit board (PCB). After soldering, the PCB can be used as a heatsink. In addition, through the use of thermal vias, the thermal pad can be attached directly to the appropriate copper plane shown in the electrical schematic for the device, or alternatively, can be attached to a special heatsink structure designed into the PCB. This design optimizes the heat transfer from the integrated circuit (IC).

For information on the Quad Flatpack No-Lead (QFN) package and its advantages, refer to Application Report, QFN/SON PCB Attachment, Texas Instruments Literature No. SLUA271. This document is available at [www.ti.com](http://www.ti.com).

The exposed thermal pad dimensions for this package are shown in the following illustration.

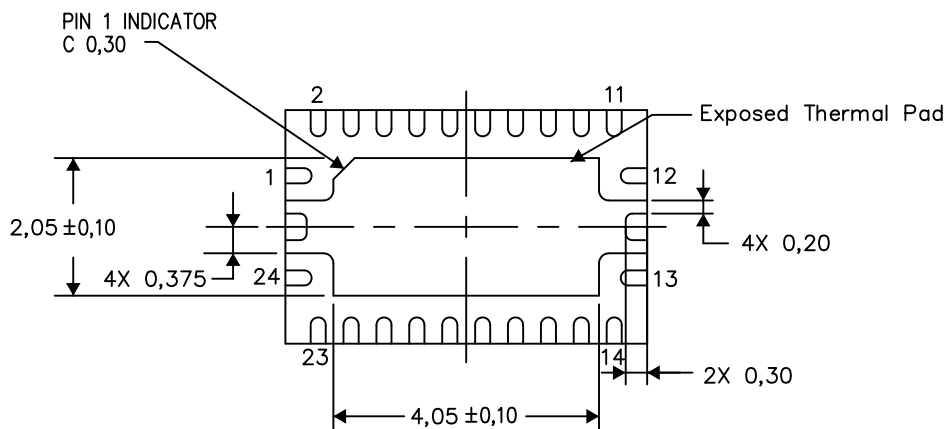

Bottom View

Exposed Thermal Pad Dimensions

4206363-4/M 08/12

NOTE: All linear dimensions are in millimeters

RHL (R-PVQFN-N24)

PLASTIC QUAD FLATPACK NO-LEAD

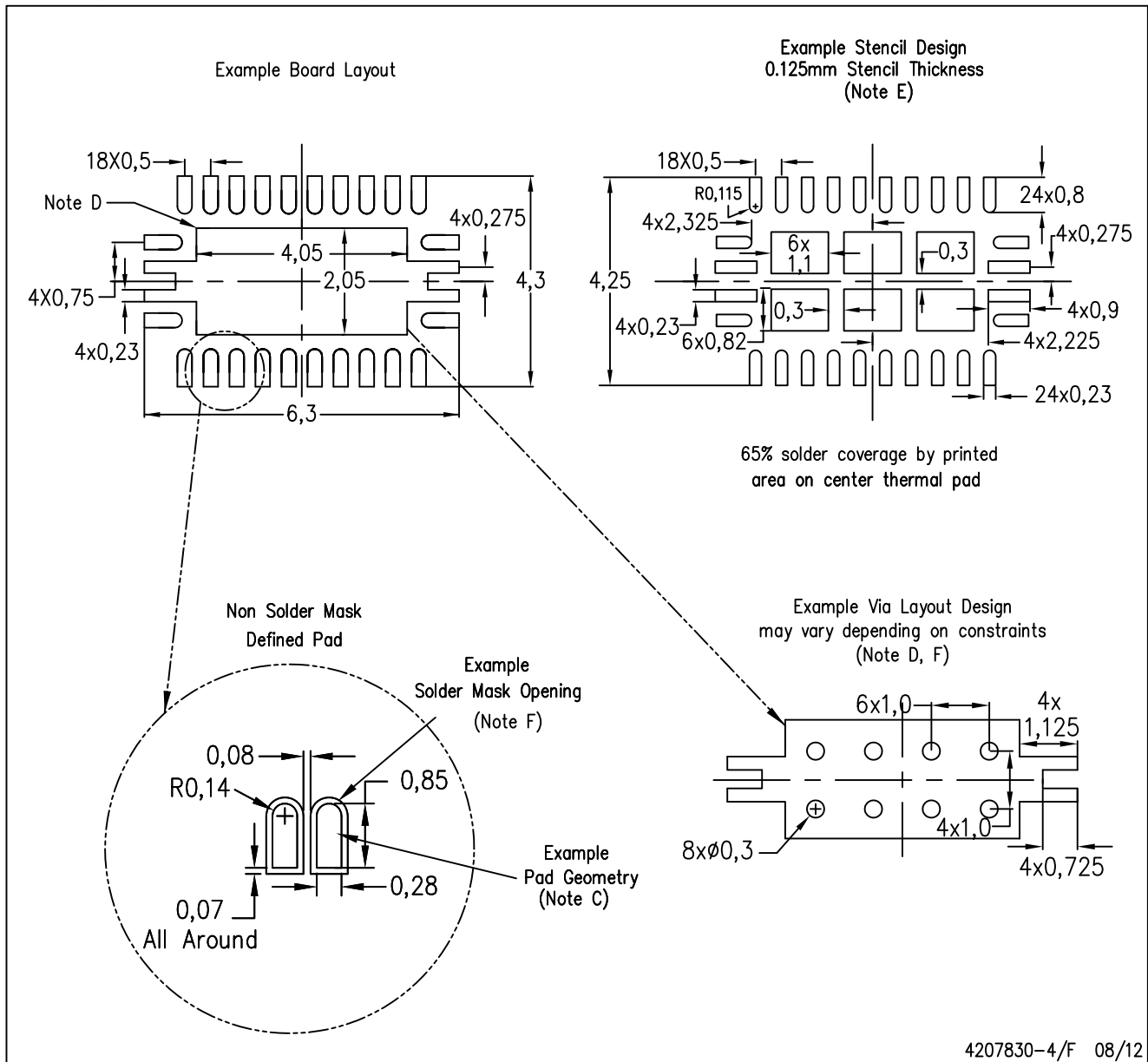

- NOTES:
- A. All linear dimensions are in millimeters.
  - B. This drawing is subject to change without notice.
  - C. Publication IPC-7351 is recommended for alternate designs.
  - D. This package is designed to be soldered to a thermal pad on the board. Refer to Application Note, Quad Flat-Pack Packages, Texas Instruments Literature No. SLUA271, and also the Product Data Sheets for specific thermal information, via requirements, and recommended board layout. These documents are available at [www.ti.com](http://www.ti.com) <<http://www.ti.com>>.
  - E. Laser cutting apertures with trapezoidal walls and also rounding corners will offer better paste release. Customers should contact their board assembly site for stencil design recommendations. Refer to IPC 7525 for stencil design considerations.
  - F. Customers should contact their board fabrication site for minimum solder mask web tolerances between signal pads.

## IMPORTANT NOTICE

Texas Instruments Incorporated and its subsidiaries (TI) reserve the right to make corrections, enhancements, improvements and other changes to its semiconductor products and services per JESD46C and to discontinue any product or service per JESD48B. Buyers should obtain the latest relevant information before placing orders and should verify that such information is current and complete. All semiconductor products (also referred to herein as "components") are sold subject to TI's terms and conditions of sale supplied at the time of order acknowledgment.

TI warrants performance of its components to the specifications applicable at the time of sale, in accordance with the warranty in TI's terms and conditions of sale of semiconductor products. Testing and other quality control techniques are used to the extent TI deems necessary to support this warranty. Except where mandated by applicable law, testing of all parameters of each component is not necessarily performed.

TI assumes no liability for applications assistance or the design of Buyers' products. Buyers are responsible for their products and applications using TI components. To minimize the risks associated with Buyers' products and applications, Buyers should provide adequate design and operating safeguards.

TI does not warrant or represent that any license, either express or implied, is granted under any patent right, copyright, mask work right, or other intellectual property right relating to any combination, machine, or process in which TI components or services are used. Information published by TI regarding third-party products or services does not constitute a license to use such products or services or a warranty or endorsement thereof. Use of such information may require a license from a third party under the patents or other intellectual property of the third party, or a license from TI under the patents or other intellectual property of TI.

Reproduction of significant portions of TI information in TI data books or data sheets is permissible only if reproduction is without alteration and is accompanied by all associated warranties, conditions, limitations, and notices. TI is not responsible or liable for such altered documentation. Information of third parties may be subject to additional restrictions.

Resale of TI components or services with statements different from or beyond the parameters stated by TI for that component or service voids all express and any implied warranties for the associated TI component or service and is an unfair and deceptive business practice. TI is not responsible or liable for any such statements.

Buyer acknowledges and agrees that it is solely responsible for compliance with all legal, regulatory and safety-related requirements concerning its products, and any use of TI components in its applications, notwithstanding any applications-related information or support that may be provided by TI. Buyer represents and agrees that it has all the necessary expertise to create and implement safeguards which anticipate dangerous consequences of failures, monitor failures and their consequences, lessen the likelihood of failures that might cause harm and take appropriate remedial actions. Buyer will fully indemnify TI and its representatives against any damages arising out of the use of any TI components in safety-critical applications.

In some cases, TI components may be promoted specifically to facilitate safety-related applications. With such components, TI's goal is to help enable customers to design and create their own end-product solutions that meet applicable functional safety standards and requirements. Nonetheless, such components are subject to these terms.

No TI components are authorized for use in FDA Class III (or similar life-critical medical equipment) unless authorized officers of the parties have executed a special agreement specifically governing such use.

Only those TI components which TI has specifically designated as military grade or "enhanced plastic" are designed and intended for use in military/aerospace applications or environments. Buyer acknowledges and agrees that any military or aerospace use of TI components which have **not** been so designated is solely at the Buyer's risk, and that Buyer is solely responsible for compliance with all legal and regulatory requirements in connection with such use.

TI has specifically designated certain components which meet ISO/TS16949 requirements, mainly for automotive use. Components which have not been so designated are neither designed nor intended for automotive use; and TI will not be responsible for any failure of such components to meet such requirements.

### Products

Audio	<a href="http://www.ti.com/audio">www.ti.com/audio</a>
Amplifiers	<a href="http://amplifier.ti.com">amplifier.ti.com</a>
Data Converters	<a href="http://dataconverter.ti.com">dataconverter.ti.com</a>
DLP® Products	<a href="http://www.dlp.com">www.dlp.com</a>
DSP	<a href="http://dsp.ti.com">dsp.ti.com</a>
Clocks and Timers	<a href="http://www.ti.com/clocks">www.ti.com/clocks</a>
Interface	<a href="http://interface.ti.com">interface.ti.com</a>
Logic	<a href="http://logic.ti.com">logic.ti.com</a>
Power Mgmt	<a href="http://power.ti.com">power.ti.com</a>
Microcontrollers	<a href="http://microcontroller.ti.com">microcontroller.ti.com</a>
RFID	<a href="http://www.ti-rfid.com">www.ti-rfid.com</a>
OMAP Mobile Processors	<a href="http://www.ti.com/omap">www.ti.com/omap</a>
Wireless Connectivity	<a href="http://www.ti.com/wirelessconnectivity">www.ti.com/wirelessconnectivity</a>

### Applications

Automotive and Transportation	<a href="http://www.ti.com/automotive">www.ti.com/automotive</a>
Communications and Telecom	<a href="http://www.ti.com/communications">www.ti.com/communications</a>
Computers and Peripherals	<a href="http://www.ti.com/computers">www.ti.com/computers</a>
Consumer Electronics	<a href="http://www.ti.com/consumer-apps">www.ti.com/consumer-apps</a>
Energy and Lighting	<a href="http://www.ti.com/energy">www.ti.com/energy</a>
Industrial	<a href="http://www.ti.com/industrial">www.ti.com/industrial</a>
Medical	<a href="http://www.ti.com/medical">www.ti.com/medical</a>
Security	<a href="http://www.ti.com/security">www.ti.com/security</a>
Space, Avionics and Defense	<a href="http://www.ti.com/space-avionics-defense">www.ti.com/space-avionics-defense</a>
Video and Imaging	<a href="http://www.ti.com/video">www.ti.com/video</a>

**TI E2E Community** [e2e.ti.com](http://e2e.ti.com)