

SN74AVC2T45 2-Bit, 2-Supply, Bus Transceiver With Configurable Level-Shifting and Translation and 3-State Outputs

1 Features

- Available in the Texas Instruments NanoFree™ Package
- V_{CC} Isolation
- 2-Rail Design
- I/Os Are 4.6 V Tolerant
- Partial-Power-Down Mode Operation
- Max Data Rates
 - 500 Mbps (1.8 V to 3.3 V)
 - 320 Mbps (<1.8 V to 3.3 V)
 - 320 Mbps (Level-Shifting to 2.5 V or 1.8 V)
 - 280 Mbps (Level-Shifting to 1.5 V)
 - 240 Mbps (Level-Shifting to 1.2 V)
- Latch-Up Performance Exceeds 100 mA Per JESD 78, Class II
- ESD Protection Exceeds JESD 22

2 Applications

- Smartphones
- Servers
- Desktop PCs and Notebooks
- Other Portable Devices

3 Description

This 2-bit noninverting bus transceiver uses two separate configurable power-supply rails. The A ports are designed to track V_{CCA} and accepts any supply voltage from 1.2 V to 3.6 V. The B ports are designed to track V_{CCB} and accepts any supply voltage from 1.2 V to 3.6 V. This allows for universal low-voltage bidirectional translation and level-shifting between any of the 1.2-V, 1.5-V, 1.8-V, 2.5-V, and 3.3-V voltage nodes.

The SN74AVC2T45 is designed for asynchronous communication between two data buses. The logic levels of the direction-control (DIR pin) input activate either the B-port outputs or the A-port outputs. The device transmits data from the A bus to the B bus when the B-port outputs are activated and from the B bus to the A bus when the A-port outputs are activated. The input circuitry on both A and B ports always is active and must have a logic HIGH or LOW level applied to prevent excess leakage current on the internal CMOS structure.

Device Information⁽¹⁾

PART NUMBER	PACKAGE	BODY SIZE (NOM)
SN74AVC2T45	SSOP (8)	2.95 mm × 2.80 mm
	VSSOP (8)	2.30 mm × 2.00 mm
	DSBGA (8)	1.89 mm × 0.89 mm

(1) For all available packages, see the orderable addendum at the end of the data sheet.

Logic Diagram (Positive Logic)

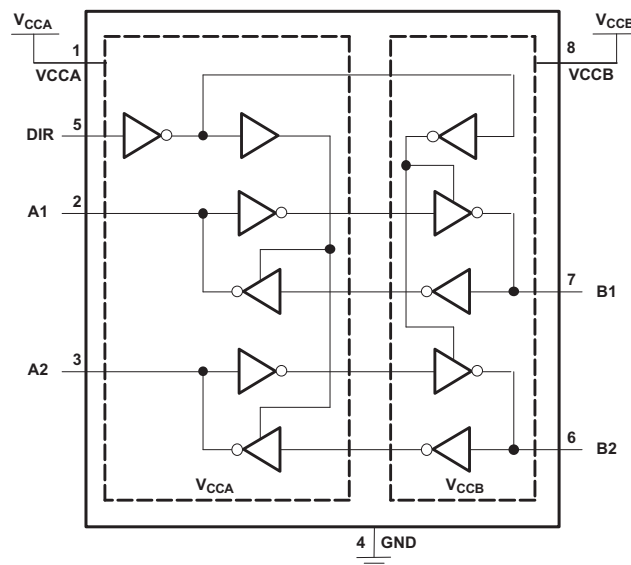

(1) Pin numbers are for the DCT and DCU packages only.



Table of Contents

1 Features	1	8 Detailed Description	13
2 Applications	1	8.1 Overview	13
3 Description	1	8.2 Functional Block Diagram	13
4 Revision History	2	8.3 Feature Description	14
5 Pin Configuration and Functions	3	8.4 Device Functional Modes	14
6 Specifications	4	9 Application and Implementation	15
6.1 Absolute Maximum Ratings	4	9.1 Application Information	15
6.2 ESD Ratings	4	9.2 Typical Applications	15
6.3 Recommended Operating Conditions	5	10 Power Supply Recommendations	18
6.4 Thermal Information	6	11 Layout	18
6.5 Electrical Characteristics	6	11.1 Layout Guidelines	18
6.6 Switching Characteristics: $V_{CCA} = 1.2\text{ V}$	7	11.2 Layout Example	18
6.7 Switching Characteristics: $V_{CCA} = 1.5\text{ V} \pm 0.1\text{ V}$	7	12 Device and Documentation Support	19
6.8 Switching Characteristics: $V_{CCA} = 1.8\text{ V} \pm 0.15\text{ V}$	8	12.1 Documentation Support	19
6.9 Switching Characteristics: $V_{CCA} = 2.5\text{ V} \pm 0.2\text{ V}$	8	12.2 Trademarks	19
6.10 Switching Characteristics: $V_{CCA} = 3.3\text{ V} \pm 0.3\text{ V}$	9	12.3 Electrostatic Discharge Caution	19
6.11 Operating Characteristics	9	12.4 Glossary	19
6.12 Typical Characteristics	10	13 Mechanical, Packaging, and Orderable Information	19
7 Parameter Measurement Information	12		

4 Revision History

Changes from Revision J (June 2007) to Revision K

Page

- Added *Pin Configuration and Functions* section, *ESD Ratings* table, *Feature Description* section, *Device Functional Modes*, *Application and Implementation* section, *Power Supply Recommendations* section, *Layout* section, *Device and Documentation Support* section, and *Mechanical, Packaging, and Orderable Information* section **1**

5 Pin Configuration and Functions

**DCT or DCU Package
8-Pin SSOP or VSSOP
(Top View)**

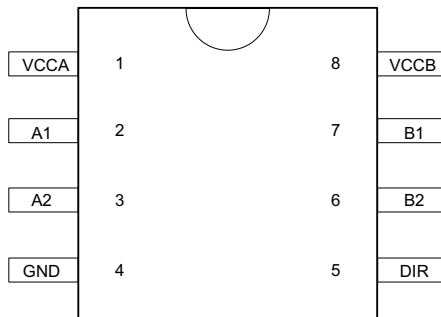

**YZP Package
8-Pin DSBGA
(Top View)**

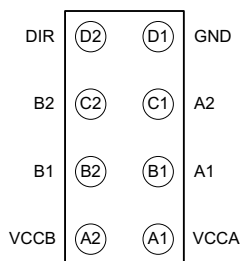

Pin Functions

NAME	PIN		DESCRIPTION
	NO. (SSOP/VSSOP)	NO. (DSBGA)	
VCCA	1	A1	Supply Voltage A
VCCB	8	A2	Supply Voltage B
GND	4	D1	Ground
A1	2	B1	Output or input depending on state of DIR. Output level depends on V _{CCA} .
A2	3	C1	Output or input depending on state of DIR. Output level depends on V _{CCA} .
B1	7	B2	Output or input depending on state of DIR. Output level depends on V _{CCB} .
B2	6	C2	Output or input depending on state of DIR. Output level depends on V _{CCB} .
DIR	5	D2	Direction Pin, Connect to GND or to VCCA

6 Specifications

6.1 Absolute Maximum Ratings⁽¹⁾

over operating free-air temperature range (unless otherwise noted)

		MIN	MAX	UNIT	
V_{CCA} V_{CCB}	Supply voltage	–0.5	4.6	V	
V_I	Input voltage ⁽²⁾	IO ports (A port)	–0.5	4.6	V
		IO ports (B port)	–0.5	4.6	
		Control inputs	–0.5	4.6	
V_O	Voltage applied to any output in the high-impedance or power-off state ⁽²⁾	A port	–0.5	4.6	V
		B port	–0.5	4.6	
V_O	Voltage applied to any output in the high or low state ^{(2) (3)}	A port	–0.5	$V_{CCA} + 0.5$	V
		B port	–0.5	$V_{CCB} + 0.5$	
I_{IK}	Input clamp current		–50	mA	
I_{OK}	Output clamp current	$V_I < 0$	–50	mA	
I_O	Continuous output current		±50	mA	
	Continuous current through V_{CCA} , V_{CCB} , or GND		±100	mA	
T_{stg}	Storage temperature	–65	150	°C	

- (1) Stresses beyond those listed under *Absolute Maximum Ratings* may cause permanent damage to the device. These are stress ratings only, which do not imply functional operation of the device at these or any other conditions beyond those indicated under *Recommended Operating Conditions*. Exposure to absolute-maximum-rated conditions for extended periods may affect device reliability.
- (2) The input negative-voltage and output voltage ratings may be exceeded if the input and output current ratings are observed.
- (3) The output positive-voltage rating may be exceeded up to 4.6 V maximum if the output current ratings are observed.

6.2 ESD Ratings

		VALUE	UNIT
$V_{(ESD)}$	Electrostatic discharge	Human body model (HBM), per ANSI/ESDA/JEDEC JS-001 ⁽¹⁾	±8000
		Charged-device model (CDM), per JEDEC specification JESD22-C101 ⁽²⁾	±1000
		Machine Model (MM), Per JEDEC specification JESD22-A115-A	±200

- (1) JEDEC document JEP155 states that 500-V HBM allows safe manufacturing with a standard ESD control process.
- (2) JEDEC document JEP157 states that 250-V CDM allows safe manufacturing with a standard ESD control process.

6.3 Recommended Operating Conditions⁽¹⁾⁽²⁾⁽³⁾

		V_{CCI} ⁽⁴⁾	V_{CCO} ⁽⁵⁾	MIN	MAX	UNIT
V_{CCA}	Supply voltage			1.2	3.6	V
V_{CCB}	Supply voltage			1.2	3.6	V
V_{IH}	High-level input voltage	Data inputs ⁽²⁾	1.2 V to 1.95 V	V_{CCI} ⁽⁴⁾ × 0.65	V	
			1.95 V to 2.7 V	1.6		
			2.7 V to 3.6 V	2		
V_{IL}	Low-level input voltage	Data inputs ⁽²⁾	1.2 V to 1.95 V	V_{CCI} ⁽⁴⁾ × 0.35	V	
			1.95 V to 2.7 V	0.7		
			2.7 V to 3.6 V	0.8		
V_{IH}	High-level input voltage	DIR (referenced to V_{CCA}) ⁽³⁾	1.2 V to 1.95 V	V_{CCA} × 0.65	V	
			1.95 V to 2.7 V	1.6		
			2.7 V to 3.6 V	2		
V_{IL}	Low-level input voltage	DIR (referenced to V_{CCA}) ⁽³⁾	1.2 V to 1.95 V	V_{CCA} × 0.35	V	
			1.95 V to 2.7 V	0.7		
			2.7 V to 3.6 V	0.8		
V_I	Input voltage			0	3.6	V
V_O	Output voltage	Active state		0	V_{CCO} ⁽⁵⁾	V
		3-state		0	3.6	
I_{OH}	High-level output current		1.2 V		–3	mA
			1.4 V to 1.6 V		–6	
			1.65 V to 1.95 V		–8	
			2.3 V to 2.7 V		–9	
			3 V to 3.6 V		–12	
I_{OL}	Low-level output current		1.2 V		3	mA
			1.4 V to 1.6 V		6	
			1.65 V to 1.95 V		8	
			2.3 V to 2.7 V		9	
			3 V to 3.6 V		12	
$\Delta t/\Delta v$	Input transition rise or fall rate				5	ns/V
T_A	Operating free-air temperature			–40	85	°C

(1) All unused data inputs of the device must be held at V_{CCI} or GND to ensure proper device operation. Refer to the TI application report, *Implications of Slow or Floating CMOS Inputs*, [SCBA004](#).

(2) For V_{CCI} values not specified in the data sheet, V_{IH} min = V_{CCI} × 0.7 V, V_{IL} max = V_{CCI} × 0.3 V.

(3) For V_{CCI} values not specified in the data sheet, V_{IH} min = V_{CCA} × 0.7 V, V_{IL} max = V_{CCA} × 0.3 V.

(4) V_{CCI} is the voltage associated with the input port supply V_{CCA} or V_{CCB} .

(5) V_{CCO} is the voltage associated with the output port supply V_{CCA} or V_{CCB} .

6.4 Thermal Information

THERMAL METRIC ⁽¹⁾		SN74AVC2T45			UNIT
		DCT (SSOP)	DCU (VSSOP)	YZP (DSBGA)	
		8 PINS	8 PINS	8 PINS	
R _{θJA}	Junction-to-ambient thermal resistance	194.4	199.3	105.8	°C/W
R _{θJC(top)}	Junction-to-case (top) thermal resistance	124.7	76.2	1.6	
R _{θJB}	Junction-to-board thermal resistance	106.8	80.6	10.8	
ψ _{JT}	Junction-to-top characterization parameter	49.8	7.1	3.1	
ψ _{JB}	Junction-to-board characterization parameter	105.8	80.1	10.8	

(1) For more information about traditional and new thermal metrics, see the *IC Package Thermal Metrics* application report, [SPRA953](#).

6.5 Electrical Characteristics

over recommended operating free-air temperature range (unless otherwise noted)⁽¹⁾ ⁽²⁾

PARAMETER	TEST CONDITIONS	V _{CCA}	V _{CCB}	T _A = 25°C			–40°C to 85°C		UNIT
				MIN	TYP	MAX	MIN	MAX	
V _{OH} ⁽³⁾	I _{OH} = –100 μA I _{OH} = –3 mA I _{OH} = –6 mA I _{OH} = –8 mA I _{OH} = –9 mA I _{OH} = –12 mA	V _I = V _{IH}	1.2 V to 3.6 V	1.2 V to 3.6 V			V _{CCO} – 0.2 V		V
			1.2 V	1.2 V	0.95				
			1.4 V	1.4 V			1.05		
			1.65 V	1.65 V			1.2		
			2.3 V	2.3 V			1.75		
			3 V	3 V			2.3		
V _{OL} ⁽³⁾	I _{OL} = 100 μA I _{OL} = 3 mA I _{OL} = 6 mA I _{OL} = 8 mA I _{OL} = 9 mA I _{OL} = 12 mA	V _I = V _{IL}	1.2 V to 3.6 V	1.2 V to 3.6 V			0.2		V
			1.2 V	1.2 V	0.25				
			1.4 V	1.4 V			0.35		
			1.65 V	1.65 V			0.45		
			2.3 V	2.3 V			0.55		
			3 V	3 V			0.7		
I _I	DIR	V _I = V _{CCA} or GND	1.2 V to 3.6 V	1.2 V to 3.6 V	±0.025	±0.25	±1		μA
I _{off}	A port	V _I or V _O = 0 to 3.6 V	0 V	0 to 3.6 V	±0.1	±1	±5		μA
	B port		0 to 3.6 V	0 V	±0.1	±1	±5		
I _{OZ} ⁽³⁾	B port	V _O = V _{CCO} or GND, V _I = V _{CCI} or GND	0 V	3.6 V	±0.5	±2.5	±5		μA
	A port		3.6 V	0 V	±0.5	±2.5	±5		
I _{CCA} ⁽³⁾	V _I = V _{CCI} or GND, I _O = 0	1.2 V to 3.6 V	1.2 V to 3.6 V			10		μA	
		0 V	3.6 V			–2			
		3.6 V	0 V			10			
I _{CCB} ⁽³⁾	V _I = V _{CCI} or GND, I _O = 0	1.2 V to 3.6 V	1.2 V to 3.6 V			10		μA	
		0 V	3.6 V			10			
		3.6 V	0 V			–2			
I _{CCA} + I _{CCB} (see Table 1)	V _I = V _{CCI} or GND, I _O = 0	1.2 V to 3.6 V	1.2 V to 3.6 V			20		μA	
C _I	Control inputs	V _I = 3.3 V or GND	3.3 V	3.3 V	2.5				pF
C _{io}	A or B port	V _O = 3.3 V or GND	3.3 V	3.3 V	6				pF

(1) V_{CCO} is the voltage associated with the output port supply V_{CCA} or V_{CCB}.

(2) V_{CCI} is the voltage associated with the input port supply V_{CCA} or V_{CCB}.

(3) V_{OH}: Output High Voltage; V_{OL}: Output Low Voltage; I_{OZ}: Hi-Z Output Current; I_{CCA}: Supply A Current; I_{CCB}: Supply B Current

Table 1. Typical Total Static Power Consumption ($I_{CCA} + I_{CCB}$)

V_{CCB}	V_{CCA}						UNIT
	0 V	1.2 V	1.5 V	1.8 V	2.5 V	3.3 V	
0 V	0	<0.5	<0.5	<0.5	<0.5	<0.5	μA
1.2 V	<0.5	<1	<1	<1	<1	1	
1.5 V	<0.5	<1	<1	<1	<1	1	
1.8 V	<0.5	<1	<1	<1	<1	<1	
2.5 V	<0.5	1	<1	<1	<1	<1	
3.3 V	<0.5	1	<1	<1	<1	<1	

6.6 Switching Characteristics: $V_{CCA} = 1.2 V$

over recommended operating free-air temperature range, $V_{CCA} = 1.2 V$ (see [Figure 11](#))

PARAMETER	FROM (INPUT)	TO (OUTPUT)	$V_{CCB} = 1.2 V$	$V_{CCB} = 1.5 V$	$V_{CCB} = 1.8 V$	$V_{CCB} = 2.5 V$	$V_{CCB} = 3.3 V$	UNIT
			TYP	TYP	TYP	TYP	TYP	
$t_{PLH}^{(1)}$	A	B	3.1	2.6	2.4	2.2	2.2	ns
$t_{PHL}^{(1)}$			3.1	2.6	2.4	2.2	2.2	
$t_{PLH}^{(1)}$	B	A	3.4	3.1	3	2.9	2.9	ns
$t_{PHL}^{(1)}$			3.4	3.1	3	2.9	2.9	
$t_{PHZ}^{(1)}$	DIR	A	5.2	5.2	5.1	5	4.8	ns
$t_{PLZ}^{(1)}$			5.2	5.2	5.1	5	4.8	
$t_{PHZ}^{(1)}$	DIR	B	5	4	3.8	2.8	3.2	ns
$t_{PLZ}^{(1)}$			5	4	3.8	2.8	3.2	
$t_{PZH}^{(1)(2)}$	DIR	A	8.4	7.1	6.8	5.7	6.1	ns
$t_{PZL}^{(1)(2)}$			8.4	7.1	6.8	5.7	6.1	
$t_{PZH}^{(1)(2)}$	DIR	B	8.3	7.8	7.5	7.2	7	ns
$t_{PZL}^{(1)(2)}$			8.3	7.8	7.5	7.2	7	

(1) t_{PLH} : Low-to-high Propagation Delay; t_{PHL} : High-to-Low Propagation Delay; t_{PHZ} : High-to-Hi-Z Propagation Delay; t_{PLZ} : Low-to-Hi-Z Propagation Delay; t_{PZH} : Hi-Z-to-High Propagation Delay; t_{PZL} : Hi-Z-to-Low Propagation Delay

(2) The enable time is a calculated value, derived using the formula shown in the [Enable Times](#) section.

6.7 Switching Characteristics: $V_{CCA} = 1.5 V \pm 0.1 V$

over recommended operating free-air temperature range, $V_{CCA} = 1.5 V \pm 0.1 V$ (see [Figure 11](#))

PARAMETER	FROM (INPUT)	TO (OUTPUT)	$V_{CCB} = 1.2 V$	$V_{CCB} = 1.5 V \pm 0.1 V$		$V_{CCB} = 1.8 V \pm 0.15 V$		$V_{CCB} = 2.5 V \pm 0.2 V$		$V_{CCB} = 3.3 V \pm 0.3 V$		UNIT
			TYP	MIN	MAX	MIN	MAX	MIN	MAX	MIN	MAX	
$t_{PLH}^{(1)}$	A	B	2.8	0.7	5.4	0.5	4.6	0.4	3.7	0.3	3.5	ns
$t_{PHL}^{(1)}$			2.8	0.7	5.4	0.5	4.6	0.4	3.7	0.3	3.5	
$t_{PLH}^{(1)}$	B	A	2.7	0.8	5.4	0.7	5.2	0.6	4.9	0.5	4.7	ns
$t_{PHL}^{(1)}$			2.7	0.8	5.4	0.7	5.2	0.6	4.9	0.5	4.7	
$t_{PHZ}^{(1)}$	DIR	A	3.9	1.3	8.5	1.3	7.8	1.1	7.7	1.4	7.6	ns
$t_{PLZ}^{(1)}$			3.9	1.3	8.5	1.3	7.8	1.1	7.7	1.4	7.6	
$t_{PHZ}^{(1)}$	DIR	B	4.7	1.1	7	1.4	6.9	1.2	6.9	1.7	7.1	ns
$t_{PLZ}^{(1)}$			4.7	1.1	7	1.4	6.9	1.2	6.9	1.7	7.1	
$t_{PZH}^{(1)(2)}$	DIR	A	7.4		12.4		12.1		11.8		11.8	ns
$t_{PZL}^{(1)(2)}$			7.4		12.4		12.1		11.8		11.8	
$t_{PZH}^{(1)(2)}$	DIR	B	6.7		13.9		12.4		11.4		11.1	ns
$t_{PZL}^{(1)(2)}$			6.7		13.9		12.4		11.4		11.1	

(1) t_{PLH} : Low-to-high Propagation Delay; t_{PHL} : High-to-Low Propagation Delay; t_{PHZ} : High-to-Hi-Z Propagation Delay; t_{PLZ} : Low-to-Hi-Z Propagation Delay; t_{PZH} : Hi-Z-to-High Propagation Delay; t_{PZL} : Hi-Z-to-Low Propagation Delay

(2) The enable time is a calculated value, derived using the formula shown in the [Enable Times](#) section.

6.8 Switching Characteristics: $V_{CCA} = 1.8\text{ V} \pm 0.15\text{ V}$

 over recommended operating free-air temperature range, $V_{CCA} = 1.8\text{ V} \pm 0.15\text{ V}$ (see [Figure 11](#))

PARAMETER	FROM (INPUT)	TO (OUTPUT)	$V_{CCB} = 1.2\text{ V}$	$V_{CCB} = 1.5\text{ V} \pm 0.1\text{ V}$		$V_{CCB} = 1.8\text{ V} \pm 0.15\text{ V}$		$V_{CCB} = 2.5\text{ V} \pm 0.2\text{ V}$		$V_{CCB} = 3.3\text{ V} \pm 0.3\text{ V}$		UNIT
			TYP	MIN	MAX	MIN	MAX	MIN	MAX	MIN	MAX	
$t_{PLH}^{(1)}$	A	B	2.7	0.5	5.2	0.4	4.3	0.2	3.4	0.2	3.1	ns
$t_{PHL}^{(1)}$			2.7	0.5	5.2	0.4	4.3	0.2	3.4	0.2	3.1	
$t_{PLH}^{(1)}$	B	A	2.4	0.7	4.7	0.5	4.4	0.5	4	0.4	3.8	ns
$t_{PHL}^{(1)}$			2.4	0.7	4.7	0.5	4.4	0.5	4	0.4	3.8	
$t_{PHZ}^{(1)}$	DIR	A	3.7	1.3	8.1	0.7	6.9	1.4	5.3	1.1	5.2	ns
$t_{PLZ}^{(1)}$			3.7	1.3	8.1	0.7	6.9	1.4	5.3	1.1	5.2	
$t_{PHZ}^{(1)}$	DIR	B	4.4	1.3	5.8	1.3	5.9	0.8	5.7	1.5	5.9	ns
$t_{PLZ}^{(1)}$			4.4	1.3	5.8	1.3	5.9	0.8	5.7	1.5	5.9	
$t_{PZH}^{(1)(2)}$	DIR	A	6.8		10.5		10.3		9.7		9.7	ns
$t_{PZL}^{(1)(2)}$			6.8		10.5		10.3		9.7		9.7	
$t_{PZH}^{(1)(2)}$	DIR	B	6.4		13.3		11.2		8.7		8.3	ns
$t_{PZL}^{(1)(2)}$			6.4		13.3		11.2		8.7		8.3	

- (1) t_{PLH} : Low-to-high Propagation Delay; t_{PHL} : High-to-Low Propagation Delay; t_{PHZ} : High-to-Hi-Z Propagation Delay; t_{PLZ} : Low-to-Hi-Z Propagation Delay; t_{PZH} : Hi-Z-to-High Propagation Delay; t_{PZL} : Hi-Z-to-Low Propagation Delay
 (2) The enable time is a calculated value, derived using the formula shown in the [Enable Times](#) section.

6.9 Switching Characteristics: $V_{CCA} = 2.5\text{ V} \pm 0.2\text{ V}$

 over recommended operating free-air temperature range, $V_{CCA} = 2.5\text{ V} \pm 0.2\text{ V}$ (see [Figure 11](#))

PARAMETER	FROM (INPUT)	TO (OUTPUT)	$V_{CCB} = 1.2\text{ V}$	$V_{CCB} = 1.5\text{ V} \pm 0.1\text{ V}$		$V_{CCB} = 1.8\text{ V} \pm 0.15\text{ V}$		$V_{CCB} = 2.5\text{ V} \pm 0.2\text{ V}$		$V_{CCB} = 3.3\text{ V} \pm 0.3\text{ V}$		UNIT
			TYP	MIN	MAX	MIN	MAX	MIN	MAX	MIN	MAX	
$t_{PLH}^{(1)}$	A	B	2.6	0.4	4.9	0.2	4	0.2	3	0.2	2.6	ns
$t_{PHL}^{(1)}$			2.6	0.4	4.9	0.2	4	0.2	3	0.2	2.6	
$t_{PLH}^{(1)}$	B	A	2.1	0.6	3.8	0.5	3.4	0.4	3	0.3	2.8	ns
$t_{PHL}^{(1)}$			2.1	0.6	3.8	0.5	3.4	0.4	3	0.3	2.8	
$t_{PHZ}^{(1)}$	DIR	A	2.4	0.7	7.9	0.8	6.4	0.8	5	0.5	4.3	ns
$t_{PLZ}^{(1)}$			2.4	0.7	7.9	0.8	6.4	0.8	5	0.5	4.3	
$t_{PHZ}^{(1)}$	DIR	B	3.8	1	4.3	0.6	4.3	0.5	4.2	1.1	4.1	ns
$t_{PLZ}^{(1)}$			3.8	1	4.3	0.6	4.3	0.5	4.2	1.1	4.1	
$t_{PZH}^{(1)(2)}$	DIR	A	5.9		8.5		7.7		7.2		6.9	ns
$t_{PZL}^{(1)(2)}$			5.9		8.5		7.7		7.2		6.9	
$t_{PZH}^{(1)(2)}$	DIR	B	5		12.8		10.4		8		6.9	ns
$t_{PZL}^{(1)(2)}$			5		12.8		10.4		8		6.9	

- (1) t_{PLH} : Low-to-high Propagation Delay; t_{PHL} : High-to-Low Propagation Delay; t_{PHZ} : High-to-Hi-Z Propagation Delay; t_{PLZ} : Low-to-Hi-Z Propagation Delay; t_{PZH} : Hi-Z-to-High Propagation Delay; t_{PZL} : Hi-Z-to-Low Propagation Delay
 (2) The enable time is a calculated value, derived using the formula shown in the [Enable Times](#) section.

6.10 Switching Characteristics: $V_{CCA} = 3.3\text{ V} \pm 0.3\text{ V}$

over recommended operating free-air temperature range, $V_{CCA} = 3.3\text{ V} \pm 0.3\text{ V}$ (see [Figure 11](#))

PARAMETER	FROM (INPUT)	TO (OUTPUT)	$V_{CCB} = 1.2\text{ V}$	$V_{CCB} = 1.5\text{ V} \pm 0.1\text{ V}$		$V_{CCB} = 1.8\text{ V} \pm 0.15\text{ V}$		$V_{CCB} = 2.5\text{ V} \pm 0.2\text{ V}$		$V_{CCB} = 3.3\text{ V} \pm 0.3\text{ V}$		UNIT
			TYP	MIN	MAX	MIN	MAX	MIN	MAX	MIN	MAX	
$t_{PLH}^{(1)}$	A	B	2.5	0.3	4.7	0.2	3.8	0.2	2.8	0.2	2.4	ns
$t_{PHL}^{(1)}$			2.5	0.3	4.7	0.2	3.8	0.2	2.8	0.2	2.4	
$t_{PLH}^{(1)}$	B	A	2.1	0.6	3.6	0.4	3.1	0.3	2.6	0.3	2.4	ns
$t_{PHL}^{(1)}$			2.1	0.6	3.6	0.4	3.1	0.3	2.6	0.3	2.4	
$t_{PHZ}^{(1)}$	DIR	A	2.9	1.1	8	1	6.5	1.3	4.7	1.2	4	ns
$t_{PLZ}^{(1)}$			2.9	1.1	8	1	6.5	1.3	4.7	1.2	4	
$t_{PHZ}^{(1)}$	DIR	B	3.4	0.5	6.6	0.3	5.6	0.3	4.6	1.1	4.2	ns
$t_{PLZ}^{(1)}$			3.4	0.5	6.6	0.3	5.6	0.3	4.6	1.1	4.2	
$t_{PZH}^{(1)(2)}$	DIR	A	5.5	10.2		8.7		7.2		6.6		ns
$t_{PZL}^{(1)(2)}$			5.5	10.2		8.7		7.2		6.6		
$t_{PZH}^{(1)(2)}$	DIR	B	5.4	12.7		10.3		7.5		6.4		ns
$t_{PZL}^{(1)(2)}$			5.4	12.7		10.3		7.5		6.4		

- (1) t_{PLH} : Low-to-high Propagation Delay; t_{PHL} : High-to-Low Propagation Delay; t_{PHZ} : High-to-Hi-Z Propagation Delay; t_{PLZ} : Low-to-Hi-Z Propagation Delay; t_{PZH} : Hi-Z-to-High Propagation Delay; t_{PZL} : Hi-Z-to-Low Propagation Delay
(2) The enable time is a calculated value, derived using the formula shown in the section.

6.11 Operating Characteristics

 $T_A = 25^\circ\text{C}$

PARAMETER		TEST CONDITIONS	$V_{CCA} = V_{CCB} = 1.2\text{ V}$	$V_{CCA} = V_{CCB} = 1.5\text{ V}$	$V_{CCA} = V_{CCB} = 1.8\text{ V}$	$V_{CCA} = V_{CCB} = 2.5\text{ V}$	$V_{CCA} = V_{CCB} = 3.3\text{ V}$	UNIT
			TYP	TYP	TYP	TYP	TYP	
$C_{pdA}^{(1)}$	A-port input, B-port output	$C_L = 0,$ $f = 10\text{ MHz},$ $t_r^{(2)} = t_f^{(2)} = 1\text{ ns}$	3	3	3	3	4	pF
	B-port input, A-port output		12	13	13	14	15	
$C_{pdB}^{(1)}$	A-port input, B-port output	$C_L = 0,$ $f = 10\text{ MHz},$ $t_r^{(2)} = t_f^{(2)} = 1\text{ ns}$	12	13	13	14	15	pF
	B-port input, A-port output		3	3	3	3	4	

- (1) Power-dissipation capacitance per transceiver
(2) t_r : Rise time; t_f : Fall time

6.12 Typical Characteristics

6.12.1 Typical Propagation Delay (A to B) vs Load Capacitance, $T_A = 25^\circ\text{C}$, $V_{CCA} = 1.2\text{ V}$

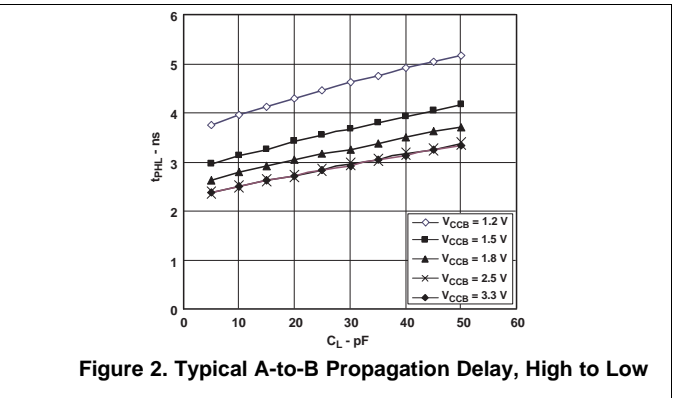
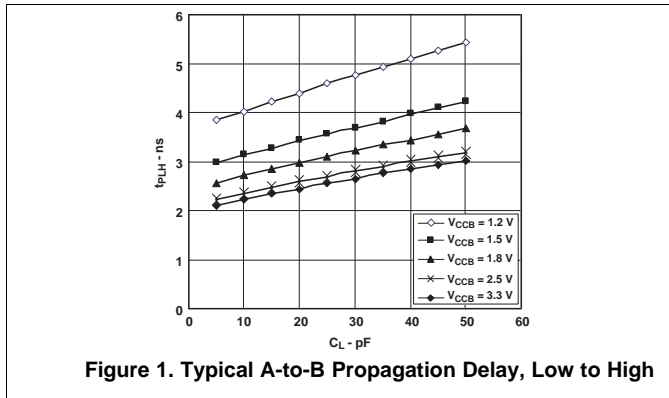

6.12.2 Typical Propagation Delay (A to B) vs Load Capacitance, $T_A = 25^\circ\text{C}$, $V_{CCA} = 1.5\text{ V}$

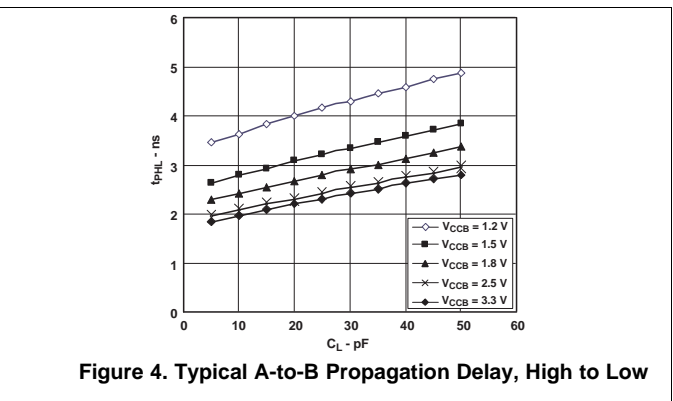
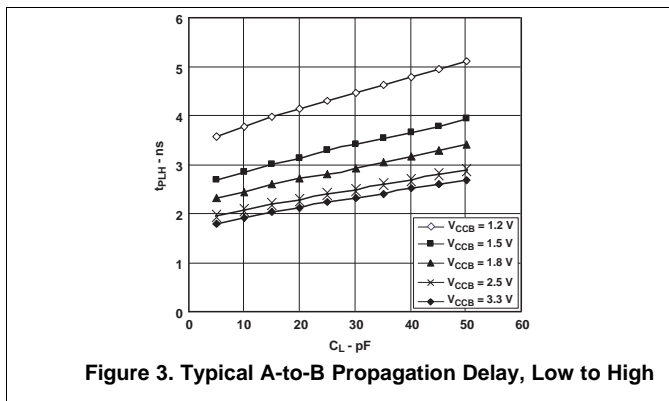

6.12.3 Typical Propagation Delay (A-to-B) vs Load Capacitance, $T_A = 25^\circ\text{C}$, $V_{CCA} = 1.8\text{ V}$

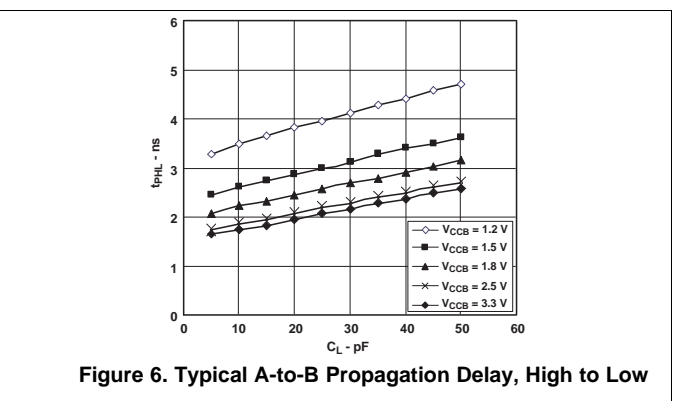
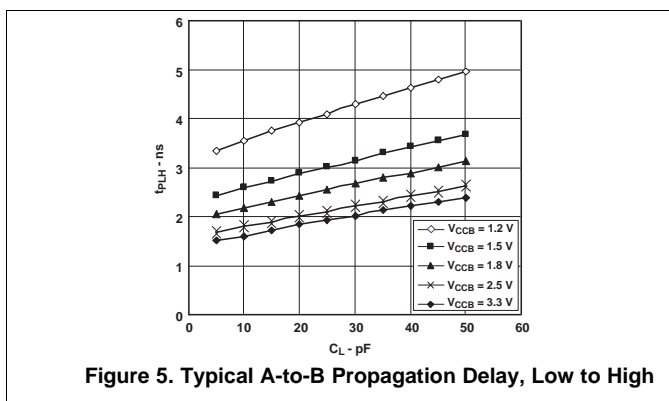

6.12.4 Typical Propagation Delay (A to B) vs Load Capacitance, $T_A = 25^\circ\text{C}$, $V_{CCA} = 2.5\text{ V}$

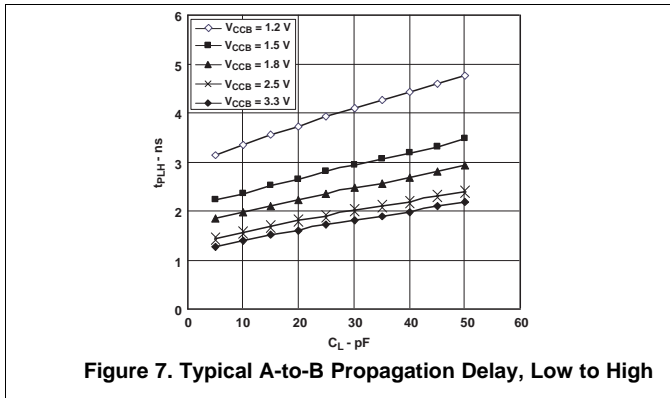

Figure 7. Typical A-to-B Propagation Delay, Low to High

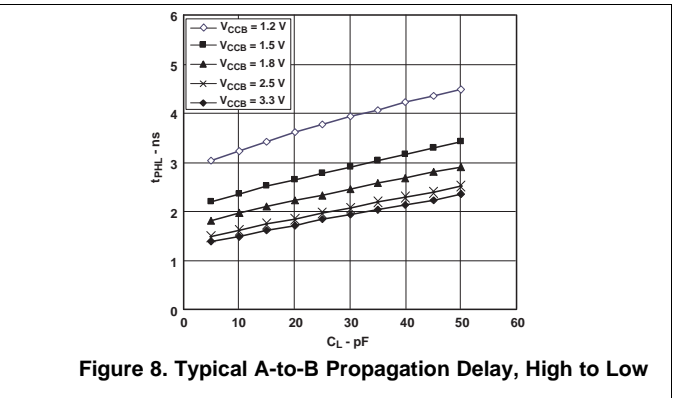

Figure 8. Typical A-to-B Propagation Delay, High to Low

6.12.5 Typical Propagation Delay (A to B) vs Load Capacitance, $T_A = 25^\circ\text{C}$, $V_{CCA} = 3.3\text{ V}$

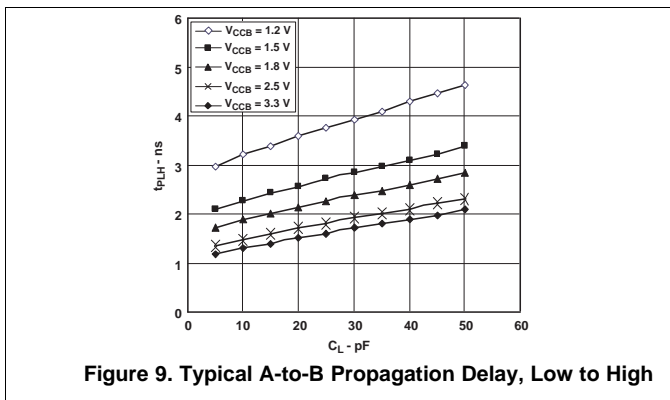

Figure 9. Typical A-to-B Propagation Delay, Low to High

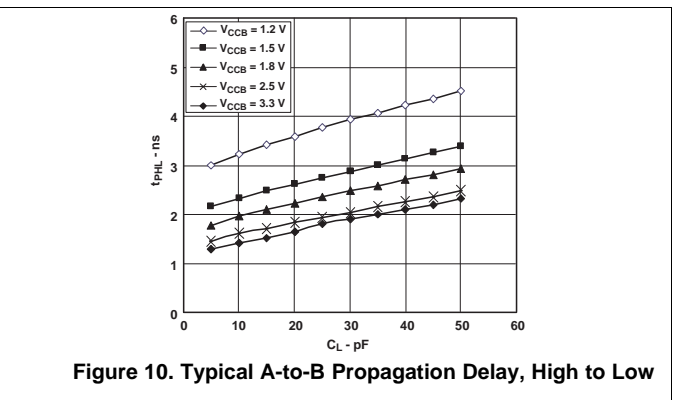
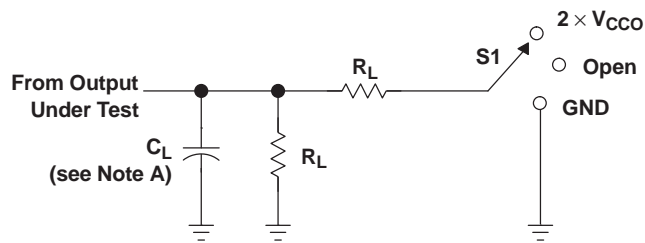

Figure 10. Typical A-to-B Propagation Delay, High to Low

7 Parameter Measurement Information

LOAD CIRCUIT

TEST	S1
t_{pd}	Open
t_{PLZ}/t_{PZL}	$2 \times V_{CCO}$
t_{PHZ}/t_{PZH}	GND

V_{CCO}	C_L	R_L	V_{TP}
1.2 V	15 pF	2 k Ω	0.1 V
1.5 V \pm 0.1 V	15 pF	2 k Ω	0.1 V
1.8 V \pm 0.15 V	15 pF	2 k Ω	0.15 V
2.5 V \pm 0.2 V	15 pF	2 k Ω	0.15 V
3.3 V \pm 0.3 V	15 pF	2 k Ω	0.3 V

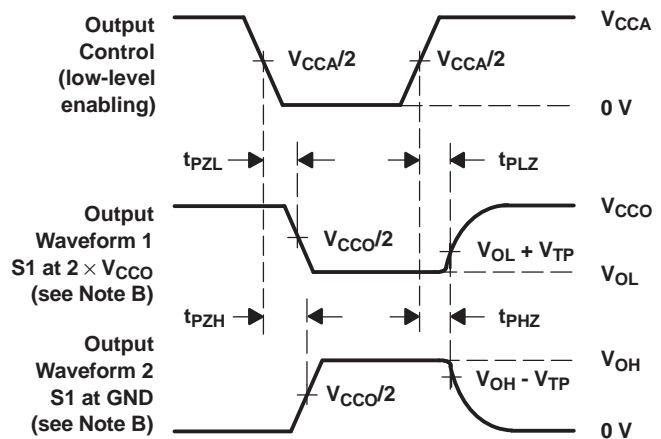
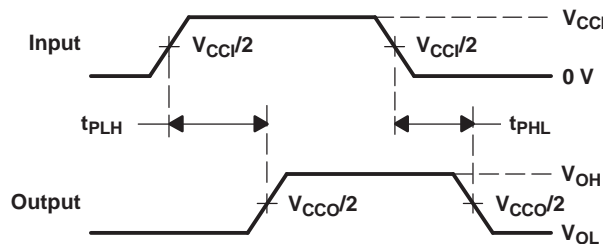
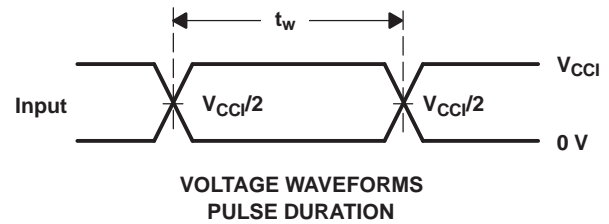

- NOTES:
- C_L includes probe and jig capacitance.
 - Waveform 1 is for an output with internal conditions such that the output is low, except when disabled by the output control. Waveform 2 is for an output with internal conditions such that the output is high, except when disabled by the output control.
 - All input pulses are supplied by generators having the following characteristics: $PRR \leq 10$ MHz, $Z_O = 50 \Omega$, $dv/dt \geq 1$ V/ns.
 - The outputs are measured one at a time, with one transition per measurement.
 - t_{PLZ} and t_{PHZ} are the same as t_{dis} .
 - t_{PZL} and t_{PZH} are the same as t_{en} .
 - t_{PLH} and t_{PHL} are the same as t_{pd} .
 - V_{CCI} is the V_{CC} associated with the input port.
 - V_{CCO} is the V_{CC} associated with the output port.

Figure 11. Load Circuit and Voltage Waveforms

8 Detailed Description

8.1 Overview

This dual-bit noninverting bus transceiver uses two separate configurable power-supply rails. The A port is designed to track V_{CCA} and accepts any supply voltage from 1.2 V to 3.6 V. The B port is designed to track V_{CCB} and accepts any supply voltage from 1.2 V to 3.6 V. This allows for universal low-voltage bidirectional translation and level-shifting between any of the 1.2 V, 1.5 V, 1.8 V, 2.5 V, and 3.3 V voltage nodes.

The SN74AVC2T45 is designed for asynchronous communication between two data buses. The logic levels of the direction-control (DIR) input activate either the B-port outputs or the A-port outputs. The device transmits data from the A bus to the B bus when the B-port outputs are activated and from the B bus to the A bus when the A-port outputs are activated. The input circuitry on both A and B ports always is active and must have a logic HIGH or LOW level applied to prevent excess internal leakage of the CMOS.

The SN74AVC2T45 is designed so that the DIR input is powered by supply voltage from V_{CCA} .

This device is fully specified for partial-power-down applications using off output current (I_{off}). The I_{off} circuitry disables the outputs, preventing damaging current backflow through the device when it is powered down.

The V_{CC} isolation feature ensures that if either V_{CC} input is at GND, both ports are put in a high-impedance state. This will prevent a false high or low logic being presented at the output.

NanoFree package technology is a major breakthrough in IC packaging concepts, using the die as the package.

8.2 Functional Block Diagram

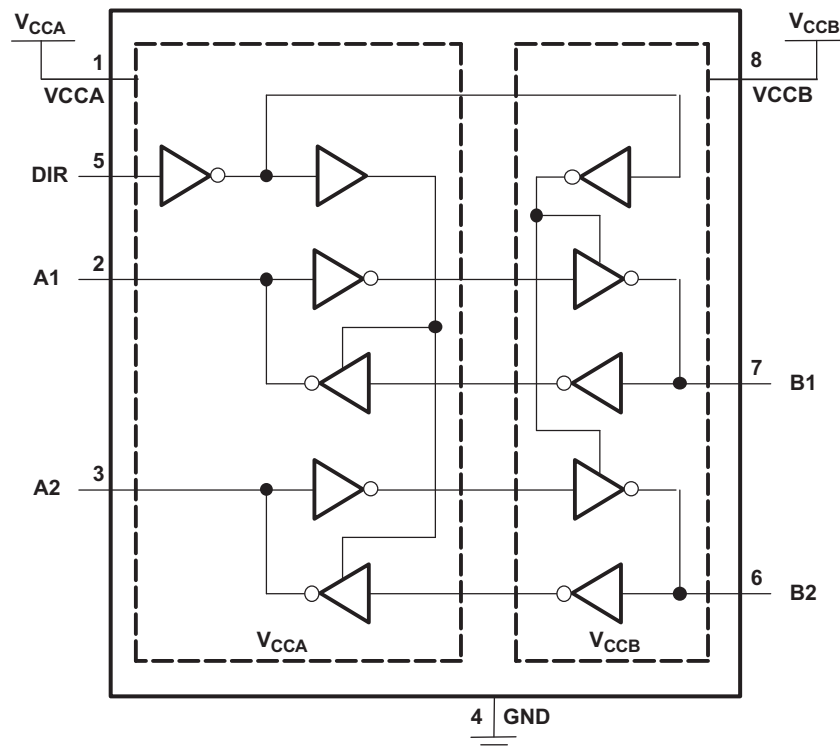

Pin numbers are for the DCT and DCU packages only.

Figure 12. Logic Diagram (Positive Logic)

8.3 Feature Description

8.3.1 VCC Isolation

The V_{CC} isolation feature ensures that if either V_{CCA} or V_{CCB} are at GND, both ports will be in a high-impedance state (I_{OZ} shown in [Electrical Characteristics](#)). This prevents false logic levels from being presented to either bus.

8.3.2 2-Rail Design

Fully configurable 2-rail design allows each port to operate over the full 1.2 V to 3.6 V power-supply range.

8.3.3 IO Ports are 4.6 V Tolerant

The IO ports are up to 4.6 V tolerant

8.3.4 Partial-Power-Down Mode

This device is fully specified for partial-power-down applications using off output current (I_{off}). The I_{off} circuitry disables the outputs, preventing damaging current backflow through the device when it is powered down.

8.4 Device Functional Modes

**Table 2. Function Table⁽¹⁾
(Each Transceiver)**

INPUT DIR	OPERATION
L	B data to A bus
H	A data to B bus

(1) Input circuits of the data IOs always are active.

9 Application and Implementation

NOTE

Information in the following applications sections is not part of the TI component specification, and TI does not warrant its accuracy or completeness. TI's customers are responsible for determining suitability of components for their purposes. Customers should validate and test their design implementation to confirm system functionality.

9.1 Application Information

The SN74AVC2T45 is used to shift IO voltage levels from one voltage domain to another. Bus A and bus B have independent power supplies, and a direction pin is used to control the direction of data flow. Unused data ports must not be floating; tie the unused port input and output to ground directly.

9.2 Typical Applications

9.2.1 Unidirectional Logic Level-Shifting Application

Figure 13 is an example circuit of the SN74AVC2T45 used in a unidirectional logic level-shifting application.

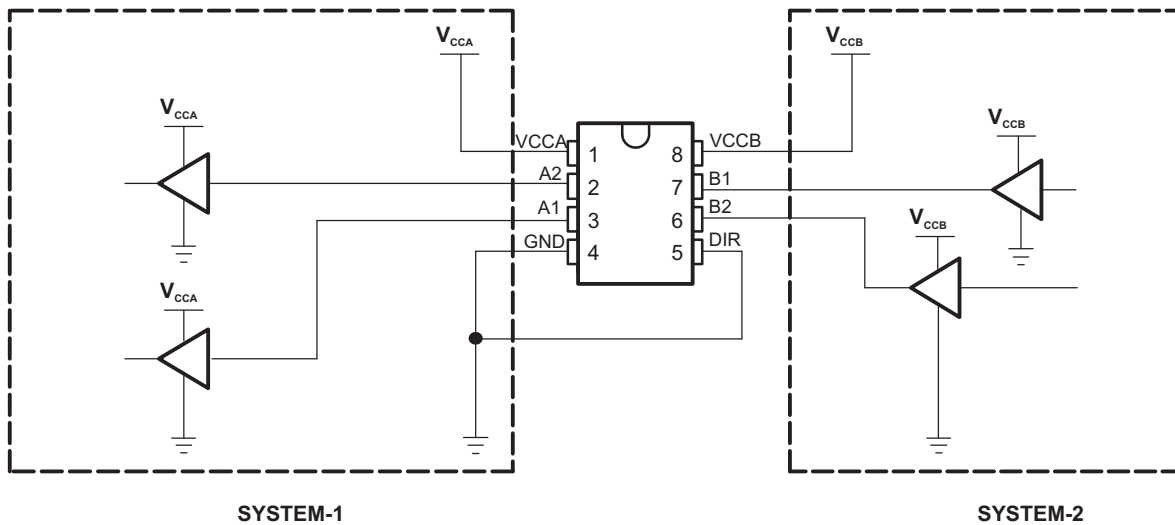

Figure 13. Unidirectional Logic Level-Shifting Application

9.2.1.1 Design Requirements

PIN	NAME	DESCRIPTION
1	VCCA	SYSTEM-1 supply voltage (1.2 V to 3.6 V)
2	A1	Output level depends on V_{CCA} .
3	A2	Output level depends on V_{CCA} .
4	GND	Device GND
5	DIR	The GND (low-level) determines B-port to A-port direction.
6	B2	Input threshold value depends on V_{CCB} .
7	B1	Input threshold value depends on V_{CCB} .
8	VCCB	SYSTEM-2 supply voltage (1.2 V to 3.6 V)

9.2.1.2 Detailed Design Procedure

This device uses drivers which are enabled depending on the state of the DIR pin. The designer must know the intended flow of data and take care not to violate any of the high or low logic levels. Unused data inputs must not be floating, as this can cause excessive internal leakage on the input CMOS structure. Make sure to tie any unused input and output ports directly to ground.

9.2.1.3 Application Curves

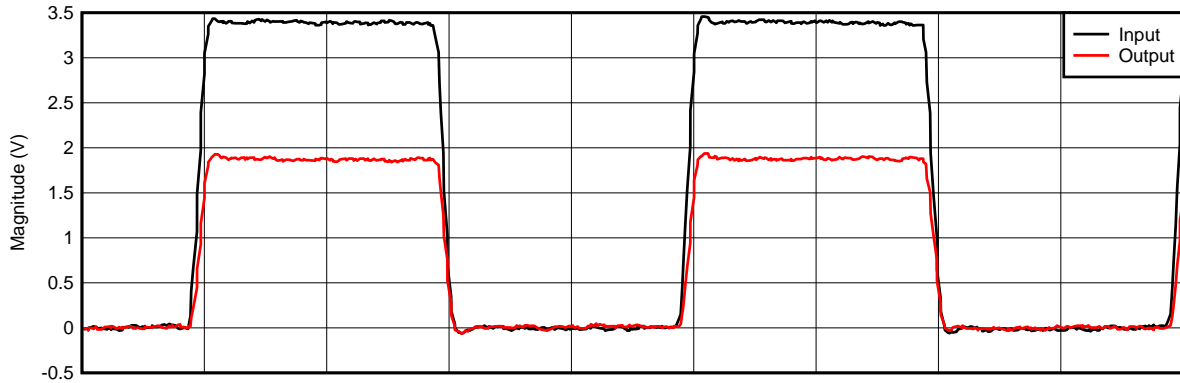

D001

Figure 14. 3.3 V to 1.8 V Level-Shifting With 1-MHz Square Wave

9.2.2 Bidirectional Logic Level-Shifting Application

Figure 15 shows the SN74AVC2T45 used in a bidirectional logic level-shifting application.

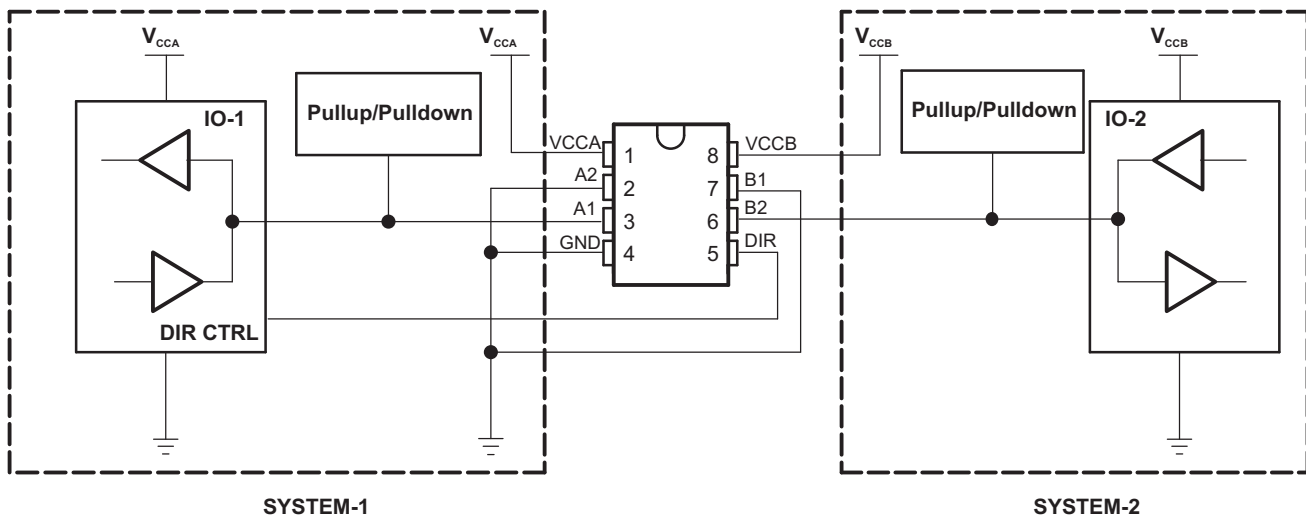

Figure 15. Bidirectional Logic Level-Shifting Application

9.2.2.1 Design Requirements

The SN74AVC2T45 does not have an output-enable (OE) pin, the system designer should take precautions to avoid bus contention between SYSTEM-1 and SYSTEM-2 when changing directions.

9.2.2.2 Detailed Design Procedure

Following is a sequence that illustrates data transmission from SYSTEM-1 to SYSTEM-2 and then from SYSTEM-2 to SYSTEM-1.

STATE	DIR CTRL	IO-1	IO-2	DESCRIPTION
1	H	Output	Input	SYSTEM-1 data to SYSTEM-2
2	H	Hi-Z	Hi-Z	SYSTEM-2 is getting ready to send data to SYSTEM-1. IO-1 and IO-2 are disabled. The bus-line state depends on pullup or pulldown. ⁽¹⁾
3	L	Hi-Z	Hi-Z	DIR bit is flipped. IO-1 and IO-2 still are disabled. The bus-line state depends on pullup or pulldown. ⁽¹⁾
4	L	Input	Output	SYSTEM-2 data to SYSTEM-1

(1) SYSTEM-1 and SYSTEM-2 must use the same conditions, i.e., both pullup or both pulldown.

9.2.2.2.1 Enable Times

Calculate the enable times for the SN74AVC2T45 using the following formulas:

- $t_{PZH} \text{ (DIR to A)} = t_{PLZ} \text{ (DIR to B)} + t_{PLH} \text{ (B to A)}$
- $t_{PZL} \text{ (DIR to A)} = t_{PHZ} \text{ (DIR to B)} + t_{PHL} \text{ (B to A)}$
- $t_{PZH} \text{ (DIR to B)} = t_{PLZ} \text{ (DIR to A)} + t_{PLH} \text{ (A to B)}$
- $t_{PZL} \text{ (DIR to B)} = t_{PHZ} \text{ (DIR to A)} + t_{PHL} \text{ (A to B)}$

In a bidirectional application, these enable times provide the maximum delay from the time the DIR bit is switched until an output is expected. For example, if the SN74AVC2T45 initially is transmitting from A to B, then the DIR bit is switched; the B port of the device must be disabled before presenting it with an input. After the B port has been disabled, an input signal applied to it appears on the corresponding A port after the specified propagation delay.

10 Power Supply Recommendations

A proper power-up sequence always should be followed to avoid excessive current on the supply pin, bus contention, oscillations, or other anomalies. To guard against such power-up problems, take the following precautions:

1. Connect ground before any supply voltage is applied.
2. Power up V_{CCA} .
3. V_{CCB} can be ramped up along with or after V_{CCA} .

11 Layout

11.1 Layout Guidelines

To ensure reliability of the device, following common printed-circuit board layout guidelines is recommended.

- Bypass capacitors should be used on power supplies. Place the capacitors as close as possible to the V_{CCA} , V_{CCB} pin and GND pin.
- Short trace lengths should be used to avoid excessive loading.

11.2 Layout Example

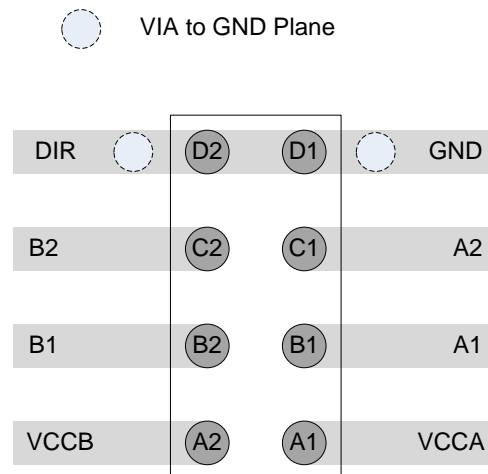

Figure 16. Layout Example for YZP Package

12 Device and Documentation Support

12.1 Documentation Support

12.1.1 Related Documentation

- *Implications of Slow or Floating CMOS Inputs*, [SCBA004](#)

12.2 Trademarks

NanoFree is a trademark of Texas Instruments.
All other trademarks are the property of their respective owners.

12.3 Electrostatic Discharge Caution



These devices have limited built-in ESD protection. The leads should be shorted together or the device placed in conductive foam during storage or handling to prevent electrostatic damage to the MOS gates.

12.4 Glossary

[SLYZ022](#) — *TI Glossary*.

This glossary lists and explains terms, acronyms, and definitions.

13 Mechanical, Packaging, and Orderable Information

The following pages include mechanical, packaging, and orderable information. This information is the most current data available for the designated devices. This data is subject to change without notice and revision of this document. For browser-based versions of this data sheet, refer to the left-hand navigation.

PACKAGING INFORMATION

Orderable Device	Status (1)	Package Type	Package Drawing	Pins	Package Qty	Eco Plan (2)	Lead/Ball Finish (6)	MSL Peak Temp (3)	Op Temp (°C)	Device Marking (4/5)	Samples
SN74AVC2T45DCTR	ACTIVE	SM8	DCT	8	3000	Green (RoHS & no Sb/Br)	CU NIPDAU	Level-1-260C-UNLIM	-40 to 85	DT2 Z	Samples
SN74AVC2T45DCTRE4	ACTIVE	SM8	DCT	8	3000	Green (RoHS & no Sb/Br)	CU NIPDAU	Level-1-260C-UNLIM	-40 to 85	DT2 Z	Samples
SN74AVC2T45DCTT	ACTIVE	SM8	DCT	8	250	Green (RoHS & no Sb/Br)	CU NIPDAU	Level-1-260C-UNLIM	-40 to 85	DT2 Z	Samples
SN74AVC2T45DCTTG4	ACTIVE	SM8	DCT	8	250	Green (RoHS & no Sb/Br)	CU NIPDAU	Level-1-260C-UNLIM	-40 to 85	DT2 Z	Samples
SN74AVC2T45DCUR	ACTIVE	VSSOP	DCU	8	3000	Green (RoHS & no Sb/Br)	CU NIPDAU CU SN	Level-1-260C-UNLIM	-40 to 85	(DT2R ~ T2) DZ	Samples
SN74AVC2T45DCURE4	ACTIVE	VSSOP	DCU	8		TBD	Call TI	Call TI	-40 to 85		Samples
SN74AVC2T45DCURG4	ACTIVE	VSSOP	DCU	8	3000	Green (RoHS & no Sb/Br)	CU NIPDAU	Level-1-260C-UNLIM	-40 to 85	DT2R	Samples
SN74AVC2T45DCUT	ACTIVE	VSSOP	DCU	8	250	Green (RoHS & no Sb/Br)	CU NIPDAU	Level-1-260C-UNLIM	-40 to 85	DT2R	Samples
SN74AVC2T45DCUTE4	ACTIVE	VSSOP	DCU	8		TBD	Call TI	Call TI	-40 to 85		Samples
SN74AVC2T45DCUTG4	ACTIVE	VSSOP	DCU	8	250	Green (RoHS & no Sb/Br)	CU NIPDAU	Level-1-260C-UNLIM	-40 to 85	DT2R	Samples
SN74AVC2T45YZPR	ACTIVE	DSBGA	YZP	8	3000	Green (RoHS & no Sb/Br)	SNAGCU	Level-1-260C-UNLIM	-40 to 85	(TD7 ~ TDN)	Samples

(1) The marketing status values are defined as follows:

ACTIVE: Product device recommended for new designs.

LIFEBUY: TI has announced that the device will be discontinued, and a lifetime-buy period is in effect.

NRND: Not recommended for new designs. Device is in production to support existing customers, but TI does not recommend using this part in a new design.

PREVIEW: Device has been announced but is not in production. Samples may or may not be available.

OBSOLETE: TI has discontinued the production of the device.

(2) Eco Plan - The planned eco-friendly classification: Pb-Free (RoHS), Pb-Free (RoHS Exempt), or Green (RoHS & no Sb/Br) - please check <http://www.ti.com/productcontent> for the latest availability information and additional product content details.

TBD: The Pb-Free/Green conversion plan has not been defined.

Pb-Free (RoHS): TI's terms "Lead-Free" or "Pb-Free" mean semiconductor products that are compatible with the current RoHS requirements for all 6 substances, including the requirement that lead not exceed 0.1% by weight in homogeneous materials. Where designed to be soldered at high temperatures, TI Pb-Free products are suitable for use in specified lead-free processes.

Pb-Free (RoHS Exempt): This component has a RoHS exemption for either 1) lead-based flip-chip solder bumps used between the die and package, or 2) lead-based die adhesive used between the die and leadframe. The component is otherwise considered Pb-Free (RoHS compatible) as defined above.

Green (RoHS & no Sb/Br): TI defines "Green" to mean Pb-Free (RoHS compatible), and free of Bromine (Br) and Antimony (Sb) based flame retardants (Br or Sb do not exceed 0.1% by weight in homogeneous material)

(3) MSL, Peak Temp. - The Moisture Sensitivity Level rating according to the JEDEC industry standard classifications, and peak solder temperature.

(4) There may be additional marking, which relates to the logo, the lot trace code information, or the environmental category on the device.

(5) Multiple Device Markings will be inside parentheses. Only one Device Marking contained in parentheses and separated by a "~" will appear on a device. If a line is indented then it is a continuation of the previous line and the two combined represent the entire Device Marking for that device.

(6) Lead/Ball Finish - Orderable Devices may have multiple material finish options. Finish options are separated by a vertical ruled line. Lead/Ball Finish values may wrap to two lines if the finish value exceeds the maximum column width.

Important Information and Disclaimer: The information provided on this page represents TI's knowledge and belief as of the date that it is provided. TI bases its knowledge and belief on information provided by third parties, and makes no representation or warranty as to the accuracy of such information. Efforts are underway to better integrate information from third parties. TI has taken and continues to take reasonable steps to provide representative and accurate information but may not have conducted destructive testing or chemical analysis on incoming materials and chemicals. TI and TI suppliers consider certain information to be proprietary, and thus CAS numbers and other limited information may not be available for release.

In no event shall TI's liability arising out of such information exceed the total purchase price of the TI part(s) at issue in this document sold by TI to Customer on an annual basis.

OTHER QUALIFIED VERSIONS OF SN74AVC2T45 :

- Automotive: [SN74AVC2T45-Q1](#)

NOTE: Qualified Version Definitions:

- Automotive - Q100 devices qualified for high-reliability automotive applications targeting zero defects

TAPE AND REEL INFORMATION

QUADRANT ASSIGNMENTS FOR PIN 1 ORIENTATION IN TAPE

*All dimensions are nominal

Device	Package Type	Package Drawing	Pins	SPQ	Reel Diameter (mm)	Reel Width W1 (mm)	A0 (mm)	B0 (mm)	K0 (mm)	P1 (mm)	W (mm)	Pin1 Quadrant
SN74AVC2T45DCTR	SM8	DCT	8	3000	180.0	13.0	3.35	4.5	1.55	4.0	12.0	Q3
SN74AVC2T45DCTT	SM8	DCT	8	250	180.0	13.0	3.35	4.5	1.55	4.0	12.0	Q3
SN74AVC2T45DCUR	VSSOP	DCU	8	3000	180.0	8.4	2.25	3.35	1.05	4.0	8.0	Q3
SN74AVC2T45DCUR	VSSOP	DCU	8	3000	180.0	9.0	2.05	3.3	1.0	4.0	8.0	Q3
SN74AVC2T45DCURG4	VSSOP	DCU	8	3000	180.0	8.4	2.25	3.35	1.05	4.0	8.0	Q3
SN74AVC2T45DCUTG4	VSSOP	DCU	8	250	180.0	8.4	2.25	3.35	1.05	4.0	8.0	Q3
SN74AVC2T45YZPR	DSBGA	YZP	8	3000	178.0	9.2	1.02	2.02	0.63	4.0	8.0	Q1

TAPE AND REEL BOX DIMENSIONS

*All dimensions are nominal

Device	Package Type	Package Drawing	Pins	SPQ	Length (mm)	Width (mm)	Height (mm)
SN74AVC2T45DCTR	SM8	DCT	8	3000	182.0	182.0	20.0
SN74AVC2T45DCTT	SM8	DCT	8	250	182.0	182.0	20.0
SN74AVC2T45DCUR	VSSOP	DCU	8	3000	202.0	201.0	28.0
SN74AVC2T45DCUR	VSSOP	DCU	8	3000	182.0	182.0	20.0
SN74AVC2T45DCURG4	VSSOP	DCU	8	3000	202.0	201.0	28.0
SN74AVC2T45DCUTG4	VSSOP	DCU	8	250	202.0	201.0	28.0
SN74AVC2T45YZPR	DSBGA	YZP	8	3000	220.0	220.0	35.0

DCT (R-PDSO-G8)

PLASTIC SMALL-OUTLINE PACKAGE

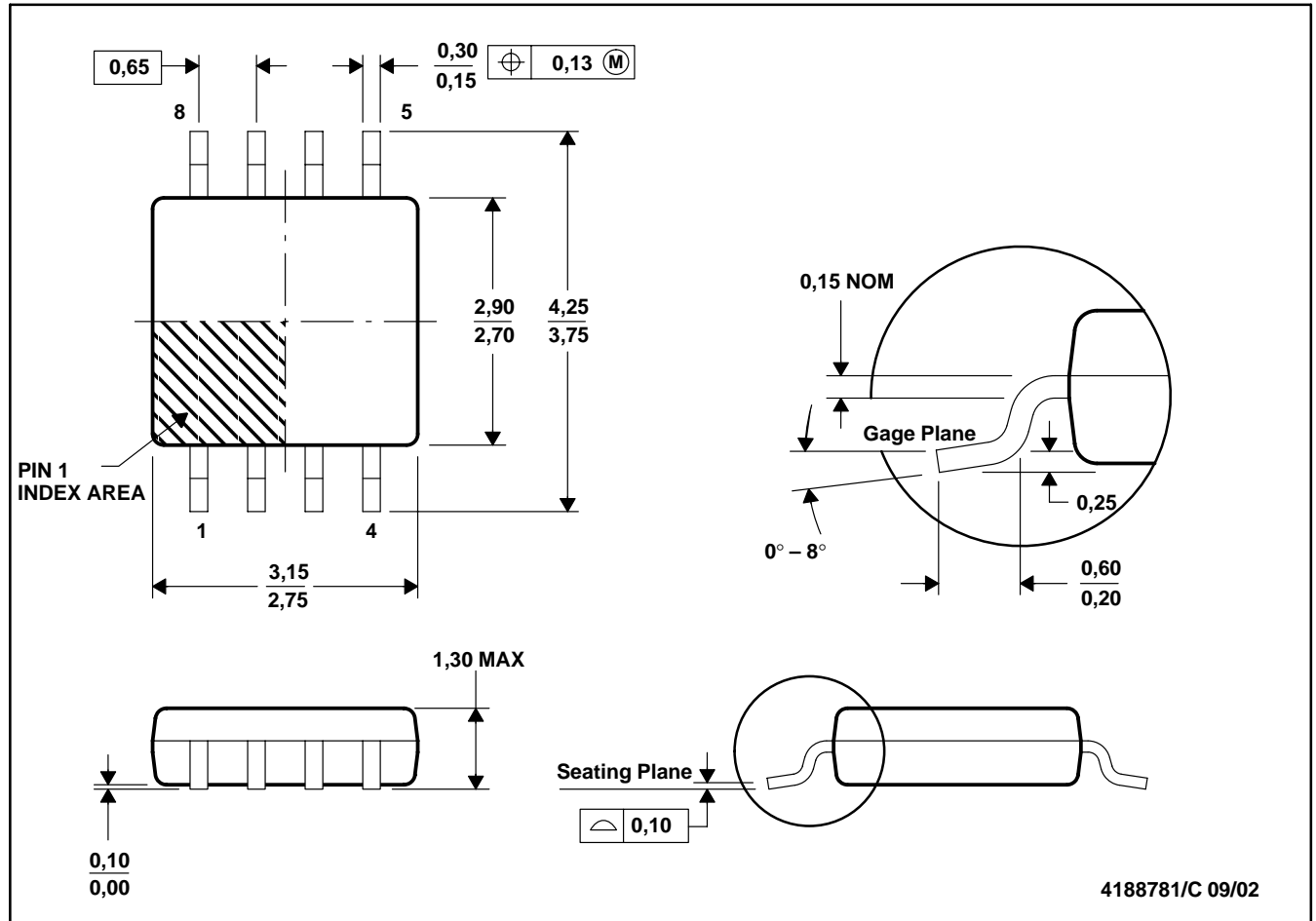

- NOTES: A. All linear dimensions are in millimeters.
B. This drawing is subject to change without notice.
C. Body dimensions do not include mold flash or protrusion
D. Falls within JEDEC MO-187 variation DA.

DCT (R-PDSO-G8)

PLASTIC SMALL OUTLINE



- NOTES:
- A. All linear dimensions are in millimeters.
 - B. This drawing is subject to change without notice.
 - C. Publication IPC-7351 is recommended for alternate designs.
 - D. Laser cutting apertures with trapezoidal walls and also rounding corners will offer better paste release. Customers should contact their board assembly site for stencil design recommendations. Refer to IPC-7525.
 - E. Customers should contact their board fabrication site for solder mask tolerances between and around signal pads.

DCU (R-PDSO-G8) PLASTIC SMALL-OUTLINE PACKAGE (DIE DOWN)

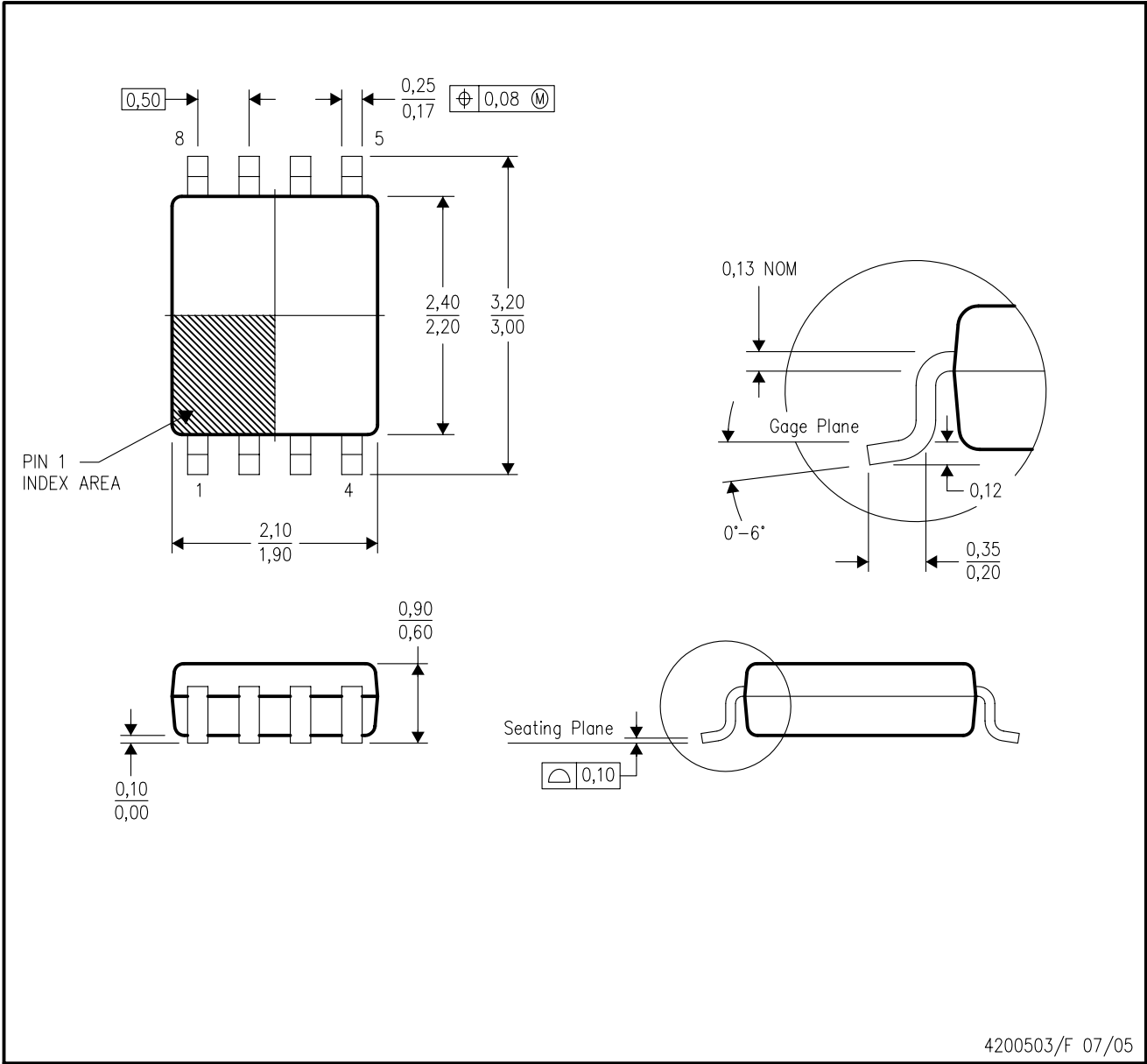

- NOTES:
- A. All linear dimensions are in millimeters.
 - B. This drawing is subject to change without notice.
 - C. Body dimensions do not include mold flash or protrusion. Mold flash and protrusion shall not exceed 0.15 per side.
 - D. Falls within JEDEC MO-187 variation CA.

DCU (S-PDSO-G8)

PLASTIC SMALL OUTLINE PACKAGE (DIE DOWN)



- NOTES:
- A. All linear dimensions are in millimeters.
 - B. This drawing is subject to change without notice.
 - C. Publication IPC-7351 is recommended for alternate designs.
 - D. Laser cutting apertures with trapezoidal walls and also rounding corners will offer better paste release. Customers should contact their board assembly site for stencil design recommendations. Refer to IPC-7525 for other stencil recommendations.
 - E. Customers should contact their board fabrication site for solder mask tolerances between and around signal pads.

YZP (R-XBGA-N8)

DIE-SIZE BALL GRID ARRAY

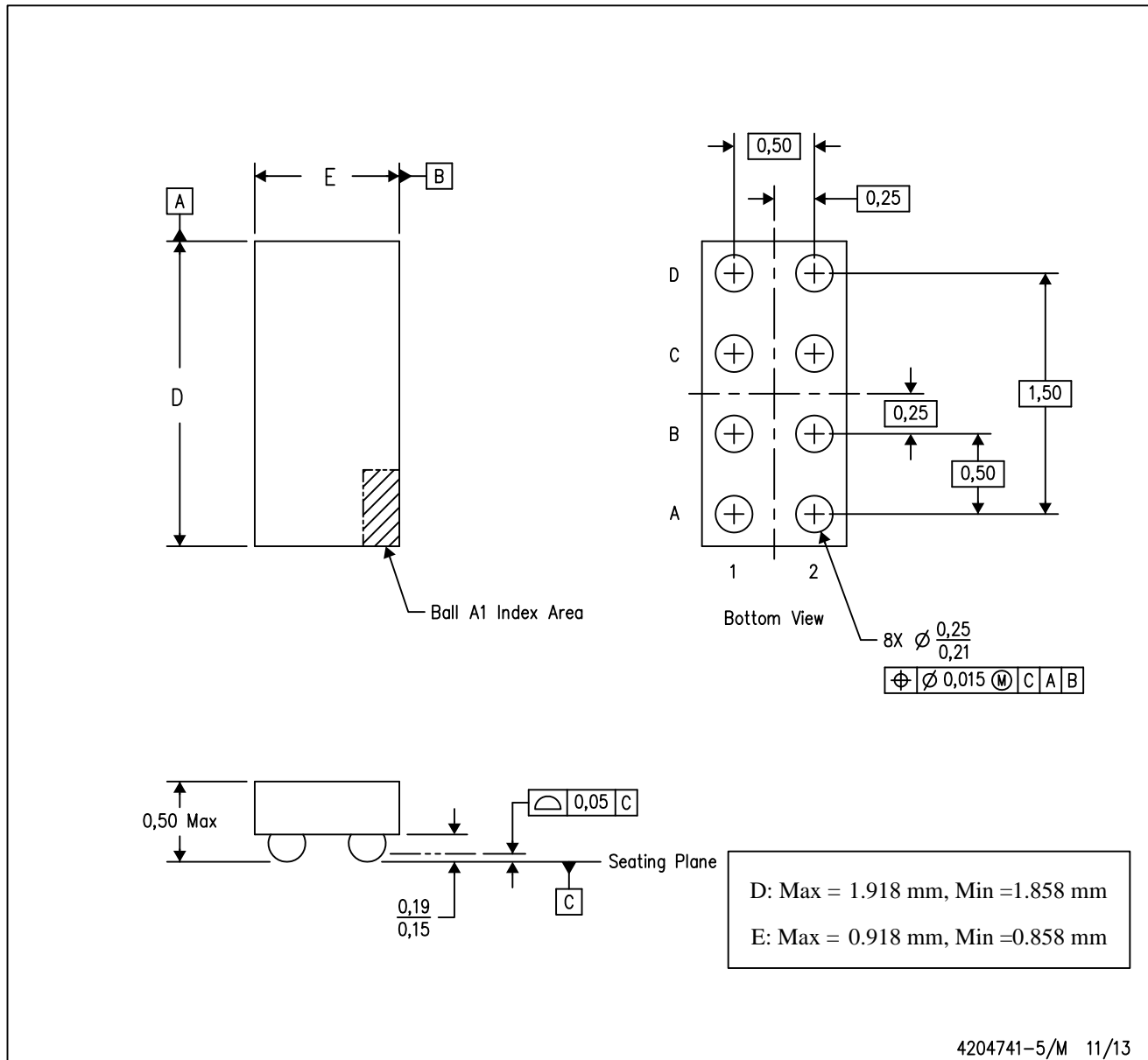

- NOTES:
- A. All linear dimensions are in millimeters. Dimensioning and tolerancing per ASME Y14.5M-1994.
 - B. This drawing is subject to change without notice.
 - C. NanoFree™ package configuration.

NanoFree is a trademark of Texas Instruments.

IMPORTANT NOTICE

Texas Instruments Incorporated and its subsidiaries (TI) reserve the right to make corrections, enhancements, improvements and other changes to its semiconductor products and services per JESD46, latest issue, and to discontinue any product or service per JESD48, latest issue. Buyers should obtain the latest relevant information before placing orders and should verify that such information is current and complete. All semiconductor products (also referred to herein as "components") are sold subject to TI's terms and conditions of sale supplied at the time of order acknowledgment.

TI warrants performance of its components to the specifications applicable at the time of sale, in accordance with the warranty in TI's terms and conditions of sale of semiconductor products. Testing and other quality control techniques are used to the extent TI deems necessary to support this warranty. Except where mandated by applicable law, testing of all parameters of each component is not necessarily performed.

TI assumes no liability for applications assistance or the design of Buyers' products. Buyers are responsible for their products and applications using TI components. To minimize the risks associated with Buyers' products and applications, Buyers should provide adequate design and operating safeguards.

TI does not warrant or represent that any license, either express or implied, is granted under any patent right, copyright, mask work right, or other intellectual property right relating to any combination, machine, or process in which TI components or services are used. Information published by TI regarding third-party products or services does not constitute a license to use such products or services or a warranty or endorsement thereof. Use of such information may require a license from a third party under the patents or other intellectual property of the third party, or a license from TI under the patents or other intellectual property of TI.

Reproduction of significant portions of TI information in TI data books or data sheets is permissible only if reproduction is without alteration and is accompanied by all associated warranties, conditions, limitations, and notices. TI is not responsible or liable for such altered documentation. Information of third parties may be subject to additional restrictions.

Resale of TI components or services with statements different from or beyond the parameters stated by TI for that component or service voids all express and any implied warranties for the associated TI component or service and is an unfair and deceptive business practice. TI is not responsible or liable for any such statements.

Buyer acknowledges and agrees that it is solely responsible for compliance with all legal, regulatory and safety-related requirements concerning its products, and any use of TI components in its applications, notwithstanding any applications-related information or support that may be provided by TI. Buyer represents and agrees that it has all the necessary expertise to create and implement safeguards which anticipate dangerous consequences of failures, monitor failures and their consequences, lessen the likelihood of failures that might cause harm and take appropriate remedial actions. Buyer will fully indemnify TI and its representatives against any damages arising out of the use of any TI components in safety-critical applications.

In some cases, TI components may be promoted specifically to facilitate safety-related applications. With such components, TI's goal is to help enable customers to design and create their own end-product solutions that meet applicable functional safety standards and requirements. Nonetheless, such components are subject to these terms.

No TI components are authorized for use in FDA Class III (or similar life-critical medical equipment) unless authorized officers of the parties have executed a special agreement specifically governing such use.

Only those TI components which TI has specifically designated as military grade or "enhanced plastic" are designed and intended for use in military/aerospace applications or environments. Buyer acknowledges and agrees that any military or aerospace use of TI components which have **not** been so designated is solely at the Buyer's risk, and that Buyer is solely responsible for compliance with all legal and regulatory requirements in connection with such use.

TI has specifically designated certain components as meeting ISO/TS16949 requirements, mainly for automotive use. In any case of use of non-designated products, TI will not be responsible for any failure to meet ISO/TS16949.

Products

Audio	www.ti.com/audio
Amplifiers	amplifier.ti.com
Data Converters	dataconverter.ti.com
DLP® Products	www.dlp.com
DSP	dsp.ti.com
Clocks and Timers	www.ti.com/clocks
Interface	interface.ti.com
Logic	logic.ti.com
Power Mgmt	power.ti.com
Microcontrollers	microcontroller.ti.com
RFID	www.ti-rfid.com
OMAP Applications Processors	www.ti.com/omap
Wireless Connectivity	www.ti.com/wirelessconnectivity

Applications

Automotive and Transportation	www.ti.com/automotive
Communications and Telecom	www.ti.com/communications
Computers and Peripherals	www.ti.com/computers
Consumer Electronics	www.ti.com/consumer-apps
Energy and Lighting	www.ti.com/energy
Industrial	www.ti.com/industrial
Medical	www.ti.com/medical
Security	www.ti.com/security
Space, Avionics and Defense	www.ti.com/space-avionics-defense
Video and Imaging	www.ti.com/video

TI E2E Community

e2e.ti.com