

## SNx4AHC08 Quadruple 2-Input Positive-AND Gates

### 1 Features

- 2-V to 5.5-V Operating Range
- Latch-Up Performance Exceeds 250 mA Per JESD 17
- ESD Protection Exceeds JESD 22

### 2 Applications

- Servers
- Network Switches
- PCs and Notebooks
- Electronic Points of Sale

### 3 Description

The SNx4AHC08 devices are quadruple 2-input positive-AND gates. These devices perform the Boolean function  $Y = A \cdot B$  or  $Y = \overline{A + B}$  in positive logic.

#### Device Information

PART NUMBER	PACKAGE <sup>1</sup>	BODY SIZE <sup>2</sup>
SN74AHC08	D (SOIC, 14)	8.65 mm × 3.90 mm
	DB (SSOP, 14)	6.20 mm × 5.30 mm
	DGV (TVSOP, 14)	3.60 mm × 4.40 mm
	N (PDIP, 14)	19.30 mm × 6.35 mm
	NS (SO, 14)	10.30 mm × 5.30 mm
	PW (TSSOP, 14)	5.00 mm × 4.40 mm
	RGY (VQFN, 14)	3.50 mm × 3.50 mm
	BQA (WQFN, 14)	3 mm × 2.5 mm
SN54AHC08	FK (LCCC, 20)	8.89 mm × 8.89 mm

1. For all available packages, see the orderable addendum at the end of the data sheet.
2. The package size (length × width) is a nominal value and includes pins, where applicable.

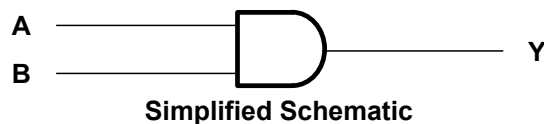

## Table of Contents

<b>1 Features</b> .....	<b>1</b>	<b>8 Detailed Description</b> .....	<b>12</b>
<b>2 Applications</b> .....	<b>1</b>	8.1 Overview.....	12
<b>3 Description</b> .....	<b>1</b>	8.2 Functional Block Diagram.....	12
<b>4 Revision History</b> .....	<b>2</b>	8.3 Feature Description.....	12
<b>5 Pin Configuration and Functions</b> .....	<b>3</b>	8.4 Device Functional Modes.....	12
<b>6 Specifications</b> .....	<b>5</b>	<b>9 Application and Implementation</b> .....	<b>13</b>
6.1 Absolute Maximum Ratings.....	5	9.1 Application Information.....	13
6.2 ESD Ratings.....	5	9.2 Typical Application.....	13
6.3 Recommended Operating Conditions.....	5	9.3 Layout.....	15
6.4 Thermal Information.....	6	<b>10 Device and Documentation Support</b> .....	<b>16</b>
6.5 Electrical Characteristics, $T_A = 25^\circ\text{C}$ .....	6	10.1 Documentation Support.....	16
6.6 Electrical Characteristics, $T_A = -55^\circ\text{C}$ to $125^\circ\text{C}$ .....	7	10.2 Receiving Notification of Documentation Updates..	16
6.7 Electrical Characteristics, $T_A = -40^\circ\text{C}$ to $125^\circ\text{C}$ .....	7	10.3 Support Resources.....	16
6.8 Switching Characteristics, $V_{CC} = 3.3\text{ V} \pm 0.3\text{ V}$ .....	8	10.4 Trademarks.....	16
6.9 Switching Characteristics, $V_{CC} = 5\text{ V} \pm 0.5\text{ V}$ .....	8	10.5 Electrostatic Discharge Caution.....	16
6.10 Noise Characteristics.....	9	10.6 Glossary.....	16
6.11 Operating Characteristics.....	9	<b>11 Mechanical, Packaging, and Orderable Information</b> .....	<b>17</b>
6.12 Typical Characteristics.....	10		
<b>7 Parameter Measurement Information</b> .....	<b>11</b>		

## 4 Revision History

NOTE: Page numbers for previous revisions may differ from page numbers in the current version.

<b>Changes from Revision J (December 2015) to Revision K (June 2023)</b>	<b>Page</b>
• Added BQA package to <i>Device Information</i> table.....	1
• Updated R $\theta$ JA values: D = 86 to 124.5, PW = 113 to 147.7 .....	6
• Added thermal value for R $\theta$ JA: BQA = 88.3, all values in $^\circ\text{C}/\text{W}$ .....	6

---

<b>Changes from Revision I (May 2013) to Revision J (December 2015)</b>	<b>Page</b>
• Added <i>ESD Ratings</i> table, <i>Feature Description</i> section, <i>Device Functional Modes</i> , <i>Application and Implementation</i> section, <i>Power Supply Recommendations</i> section, <i>Layout</i> section, <i>Device and Documentation Support</i> section, and <i>Mechanical, Packaging, and Orderable Information</i> section.....	1

### 5 Pin Configuration and Functions

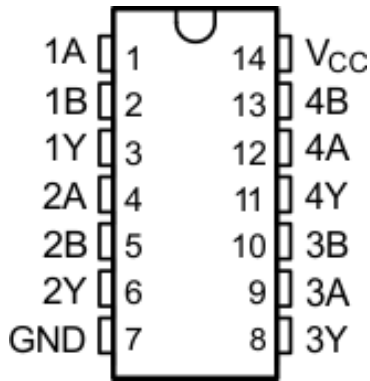

Figure 5-1. D, DB, DGV, N, NS, PW, or W Package  
14-Pin SOIC, SSOP, TVSOP, PDIP, SO, or TSSOP  
(Top View)

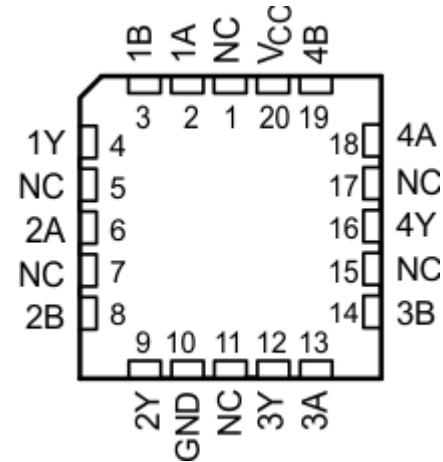

Figure 5-2. FK Package 20-Pin LCCC (Top View)

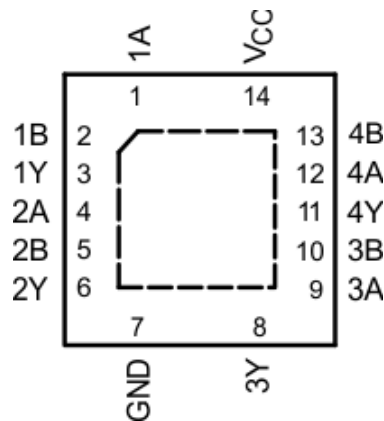

Figure 5-3. RGY or BQA Package 14-Pin VQFN or WQFN (Top View)

NAME	PIN			I/O	DESCRIPTION
	SOIC, SSOP, TVSOP, PDIP, SO, TSSOP	VQFN, WQFN	LCCC		
1A	1	1	2	I	1A Input
1B	2	2	3	I	1B Input
1Y	3	3	4	O	1Y Output
2A	4	4	6	I	2A Input
2B	5	5	8	I	2B Input
2Y	6	6	9	O	2Y Output
3Y	8	8	12	O	3Y Output
3A	9	9	13	I	3A Input
3B	10	10	14	I	3B Input
4Y	11	11	16	O	4Y Output
4A	12	12	18	I	4A Input
4B	13	13	19	I	4B Input
GND	7	7	10	—	Ground Pin

**SN54AHC08, SN74AHC08**

SCLS236K – OCTOBER 1995 – REVISED JUNE 2023

PIN				I/O	DESCRIPTION
NAME	SOIC, SSOP, TVSOP, PDIP, SO, TSSOP	VQFN, WQFN	LCCC		
NC	—	—	1, 5, 7, 11, 15, 17	—	No Connection
V <sub>CC</sub>	14	14	20	—	Power Pin

## 6 Specifications

### 6.1 Absolute Maximum Ratings

over operating free-air temperature range (unless otherwise noted)<sup>(1)</sup>

		MIN	MAX	UNIT
V <sub>CC</sub>	Supply voltage	-0.5	7	V
V <sub>I</sub>	Input voltage <sup>(2)</sup>	-0.5	7	V
V <sub>O</sub>	Output voltage, V <sub>O</sub> <sup>(2)</sup>	-0.5	V <sub>CC</sub> + 0.5	V
I <sub>IK</sub>	Input clamp current	V <sub>I</sub> < 0		-20 mA
I <sub>OK</sub>	Output clamp current	V <sub>O</sub> < 0 or V <sub>O</sub> > V <sub>CC</sub>		±20 mA
I <sub>O</sub>	Continuous output current	V <sub>O</sub> = 0 to V <sub>CC</sub>		±25 mA
	Continuous current through V <sub>CC</sub> or GND			±50 mA
T <sub>J</sub>	Junction temperature			150 °C
T <sub>stg</sub>	Storage temperature	-65	150	°C

- (1) Stresses beyond those listed under *Absolute Maximum Ratings* may cause permanent damage to the device. These are stress ratings only, which do not imply functional operation of the device at these or any other conditions beyond those indicated under *Recommended Operating Conditions*. Exposure to absolute-maximum-rated conditions for extended periods may affect device reliability.
- (2) The input and output voltage ratings may be exceeded if the input and output current ratings are observed.

### 6.2 ESD Ratings

		VALUE	UNIT
V <sub>(ESD)</sub>	Electrostatic discharge	Human body model (HBM), per ANSI/ESDA/JEDEC JS-001 <sup>1</sup>	±2000
		Charged device model (CDM), per JEDEC specification JESD22-C101 <sup>2</sup>	±1000

- (1) JEDEC document JEP155 states that 500-V HBM allows safe manufacturing with a standard ESD control process. Manufacturing with less than 500-V HBM is possible with the necessary precautions.
- (2) JEDEC document JEP157 states that 250-V CDM allows safe manufacturing with a standard ESD control process. Manufacturing with less than 250-V CDM is possible with the necessary precautions.

### 6.3 Recommended Operating Conditions

over operating free-air temperature range (unless otherwise noted) <sup>(1)</sup>

		MIN	MAX	UNIT
V <sub>CC</sub>	Supply voltage	2	5.5	V
V <sub>IH</sub>	High-level input voltage	V <sub>CC</sub> = 2 V	1.5	V
		V <sub>CC</sub> = 3 V	2.1	
		V <sub>CC</sub> = 5.5 V	3.85	
V <sub>IL</sub>	Low-level Input voltage	V <sub>CC</sub> = 2 V	0.5	V
		V <sub>CC</sub> = 3 V	0.9	
		V <sub>CC</sub> = 5.5 V	1.65	
V <sub>I</sub>	Input voltage	0	5.5	V
V <sub>O</sub>	Output voltage	0	V <sub>CC</sub>	V
I <sub>OH</sub>	High-level output current	V <sub>CC</sub> = 2 V	-50	mA
		V <sub>CC</sub> = 3.3 V ± 0.3 V	-4	
		V <sub>CC</sub> = 5 V ± 0.5 V	-8	
I <sub>OL</sub>	Low-level output current	V <sub>CC</sub> = 2 V	50	mA
		V <sub>CC</sub> = 3.3 V ± 0.3 V	4	
		V <sub>CC</sub> = 5 V ± 0.5 V	8	
Δt/Δv	Input Transition rise or fall rate	V <sub>CC</sub> = 3.3 V ± 0.3 V	100	ns/V
		V <sub>CC</sub> = 5 V ± 0.5 V	20	

**SN54AHC08, SN74AHC08**

SCLS236K – OCTOBER 1995 – REVISED JUNE 2023

 over operating free-air temperature range (unless otherwise noted) <sup>(1)</sup>

			MIN	MAX	UNIT
T <sub>A</sub>	Operating free-air temperature	SN54AHC08	-55	125	°C
		SN74AHC08	-40	125	

(1) All unused inputs of the device must be held at V<sub>CC</sub> or GND to ensure proper device operation. Refer to the TI application report, *Implications of Slow or Floating CMOS Inputs*, [SCBA004](#).

## 6.4 Thermal Information

THERMAL METRIC <sup>(1)</sup>	SN74AHC08								UNIT	
	D (SOIC)	DB (SSOP)	DGV (TVSOP)	N (PDIP)	NS (SO)	PW (TSSOP)	RGY (VQFN)	BQA (WQFN)		
	14 PINS	14 PINS	14 PINS	14 PINS	14 PINS	14 PINS	14 PINS	14 PINS		
R <sub>θJA</sub>	Junction-to-ambient thermal resistance	124.5	96	127	80	76	147.7	47	88.3	°C/W

(1) For more information about traditional and new thermal metrics, see the *Semiconductor and IC Package Thermal Metrics* application report, [SPRA953](#).

## 6.5 Electrical Characteristics, T<sub>A</sub> = 25°C

over operating free-air temperature range (unless otherwise noted)

PARAMETER	TEST CONDITIONS	V <sub>CC</sub>	MIN	TYP	MAX	UNIT
V <sub>OH</sub>	I <sub>OH</sub> = -50 μA	2 V	1.9	2		V
		3 V	2.9	3		
		4.5 V	4.4	4.5		
	I <sub>OH</sub> = -4 mA	3 V	2.58			
	I <sub>OH</sub> = -8 mA	4.5 V	3.94			
V <sub>OL</sub>	I <sub>OL</sub> = 50 μA	2 V			0.1	V
		3 V			0.1	
		4.5 V			0.1	
	I <sub>OH</sub> = 4 mA	3 V			0.36	
	I <sub>OH</sub> = 8 mA	4.5 V			0.36	
I <sub>I</sub>	V <sub>I</sub> = 5.5 V or GND	0 V to 5.5 V			±0.1	μA
I <sub>CC</sub>	V <sub>I</sub> = V <sub>CC</sub> or GND, I <sub>O</sub> = 0	5.5 V			2	μA
C <sub>I</sub>	V <sub>I</sub> = V <sub>CC</sub> or GND	5 V		4	10	pF

## 6.6 Electrical Characteristics, $T_A = -55^\circ\text{C}$ to $125^\circ\text{C}$

over operating free-air temperature range (unless otherwise noted)

PARAMETER	TEST CONDITIONS	$V_{CC}$	SN54AHC08		UNIT
			MIN	MAX	
$V_{OH}$	$I_{OH} = -50 \mu\text{A}$	2 V	1.9		V
		3 V	2.9		
		4.5 V	4.4		
	$I_{OH} = -4 \text{ mA}$	3 V	2.48		
	$I_{OH} = -8 \text{ mA}$	4.5 V	3.8		
$V_{OL}$	$I_{OL} = 50 \mu\text{A}$	2 V		0.1	V
		3 V		0.1	
		4.5 V		0.1	
	$I_{OH} = 4 \text{ mA}$	3 V		0.5	
	$I_{OH} = 8 \text{ mA}$	4.5 V		0.5	
$I_I$	$V_I = 5.5 \text{ V}$ or GND	0 V to 5.5 V		$\pm 1^{(1)}$	$\mu\text{A}$
$I_{CC}$	$V_I = V_{CC}$ or GND, $I_O = 0$	5.5 V		20	$\mu\text{A}$
$C_i$	$V_I = V_{CC}$ or GND	5 V			pF

(1) On products compliant to MIL-PRF-38535, this parameter is not production tested at  $V_{CC} = 0 \text{ V}$ .

## 6.7 Electrical Characteristics, $T_A = -40^\circ\text{C}$ to $125^\circ\text{C}$

over operating free-air temperature range (unless otherwise noted)

PARAMETER	TEST CONDITIONS	$V_{CC}$	$T_A$	SN74AHC08		UNIT	
				MIN	MAX		
$V_{OH}$	$I_{OH} = -50 \mu\text{A}$	2 V		1.9		V	
		3 V		2.9			
		4.5 V		4.4			
	$I_{OH} = -4 \text{ mA}$	3 V		2.48			
	$I_{OH} = -8 \text{ mA}$	4.5 V		3.8			
$V_{OL}$	$I_{OL} = 50 \mu\text{A}$	2 V			0.1	V	
		3 V			0.1		
		4.5 V			0.1		
	$I_{OH} = 4 \text{ mA}$	3 V	$T_A = -40^\circ\text{C}$ to $85^\circ\text{C}$		0.44		
			$T_A = -40^\circ\text{C}$ to $125^\circ\text{C}$ Recommended		0.5		
	$I_{OH} = 8 \text{ mA}$	4.5 V	$T_A = -40^\circ\text{C}$ to $85^\circ\text{C}$		0.44		
			$T_A = -40^\circ\text{C}$ to $125^\circ\text{C}$ Recommended		0.5		
$I_I$	$V_I = 5.5 \text{ V}$ or GND	0 V to 5.5 V			$\pm 1$	$\mu\text{A}$	
$I_{CC}$	$V_I = V_{CC}$ or GND, $I_O = 0$	5.5 V			20	$\mu\text{A}$	
$C_i$	$V_I = V_{CC}$ or GND	5 V	$T_A = -40^\circ\text{C}$ to $85^\circ\text{C}$		10	pF	

## 6.8 Switching Characteristics, $V_{CC} = 3.3 V \pm 0.3 V$

over recommended operating free-air temperature range (unless otherwise noted) (see [Load Circuit and Voltage Waveforms](#))

PARAMETER	FROM (INPUT)	TO (OUTPUT)	LOAD CAPACITANCE	$T_A$	MIN	TYP	MAX	UNIT
$t_{PLH}, t_{PHL}$	A or B	Y	$C_L = 15 \text{ pF}$	$T_A = 25^\circ\text{C}$		6.2 <sup>(1)</sup>	8.8 <sup>(1)</sup>	ns
				$T_A = -55^\circ\text{C to } 125^\circ\text{C, SN54AHC08}$		1 <sup>(1)</sup>	10.5 <sup>(1)</sup>	
				$T_A = -40^\circ\text{C to } 85^\circ\text{C, SN74AHC08}$		1	10.5	
				$T_A = -40^\circ\text{C to } 125^\circ\text{C Recommended, SN74AHC08}$		1	10.5	
$t_{PLH}, t_{PHL}$	A or B	Y	$C_L = 50 \text{ pF}$	$T_A = 25^\circ\text{C}$		8.7	12.3	ns
				$T_A = -55^\circ\text{C to } 125^\circ\text{C, SN54AHC08}$		1	14	
				$T_A = -40^\circ\text{C to } 85^\circ\text{C, SN74AHC08}$		1	14	
				$T_A = -40^\circ\text{C to } 125^\circ\text{C Recommended, SN74AHC08}$		1	14	

(1) On products compliant to MIL-PRF-38535, this parameter is not production tested.

## 6.9 Switching Characteristics, $V_{CC} = 5 V \pm 0.5 V$

over recommended operating free-air temperature range (unless otherwise noted) (see [Load Circuit and Voltage Waveforms](#))

PARAMETER	FROM (INPUT)	TO (OUTPUT)	LOAD CAPACITANCE	$T_A$	MIN	TYP	MAX	UNIT
$t_{PLH}, t_{PHL}$	A or B	Y	$C_L = 15 \text{ pF}$	$T_A = 25^\circ\text{C}$		4.3 <sup>(1)</sup>	5.9 <sup>(1)</sup>	ns
				$T_A = -55^\circ\text{C to } 125^\circ\text{C, SN54AHC08}$		1 <sup>(1)</sup>	7 <sup>(1)</sup>	
				$T_A = -40^\circ\text{C to } 85^\circ\text{C, SN74AHC08}$		1	7	
				$T_A = -40^\circ\text{C to } 125^\circ\text{C Recommended, SN74AHC08}$		1	7	
$t_{PLH}, t_{PHL}$	A or B	Y	$C_L = 50 \text{ pF}$	$T_A = 25^\circ\text{C}$		5.8	7.9	ns
				$T_A = -55^\circ\text{C to } 125^\circ\text{C, SN54AHC08}$		1	9	
				$T_A = -40^\circ\text{C to } 85^\circ\text{C, SN74AHC08}$		1	9	
				$T_A = -40^\circ\text{C to } 125^\circ\text{C Recommended, SN74AHC08}$		1	9	

(1) On products compliant to MIL-PRF-38535, this parameter is not production tested.



## 6.10 Noise Characteristics

$V_{CC} = 5\text{ V}$ ,  $C_L = 50\text{ pF}$ ,  $T_A = 25^\circ\text{C}$ <sup>(1)</sup>

		SN74AHC08		UNIT
		MIN	MAX	
$V_{OL(P)}$	Quiet output, maximum dynamic $V_{OL}$		0.8	V
$V_{OL(V)}$	Quiet output, minimum dynamic $V_{OL}$		-0.8	V
$V_{OH(V)}$	Quiet output, minimum dynamic $V_{OH}$	4.4		V
$V_{IH(D)}$	High-level dynamic input voltage	3.5		V
$V_{IL(D)}$	Low-level dynamic input voltage		1.5	V

(1) Characteristics are for surface-mount packages only.

## 6.11 Operating Characteristics

$V_{CC} = 5\text{ V}$ ,  $T_A = 25^\circ\text{C}$

PARAMETER		TEST CONDITIONS	TYP	UNIT
$C_{pd}$	Power dissipation capacitance	No load, $f = 1\text{ MHz}$	18	pF

## 6.12 Typical Characteristics

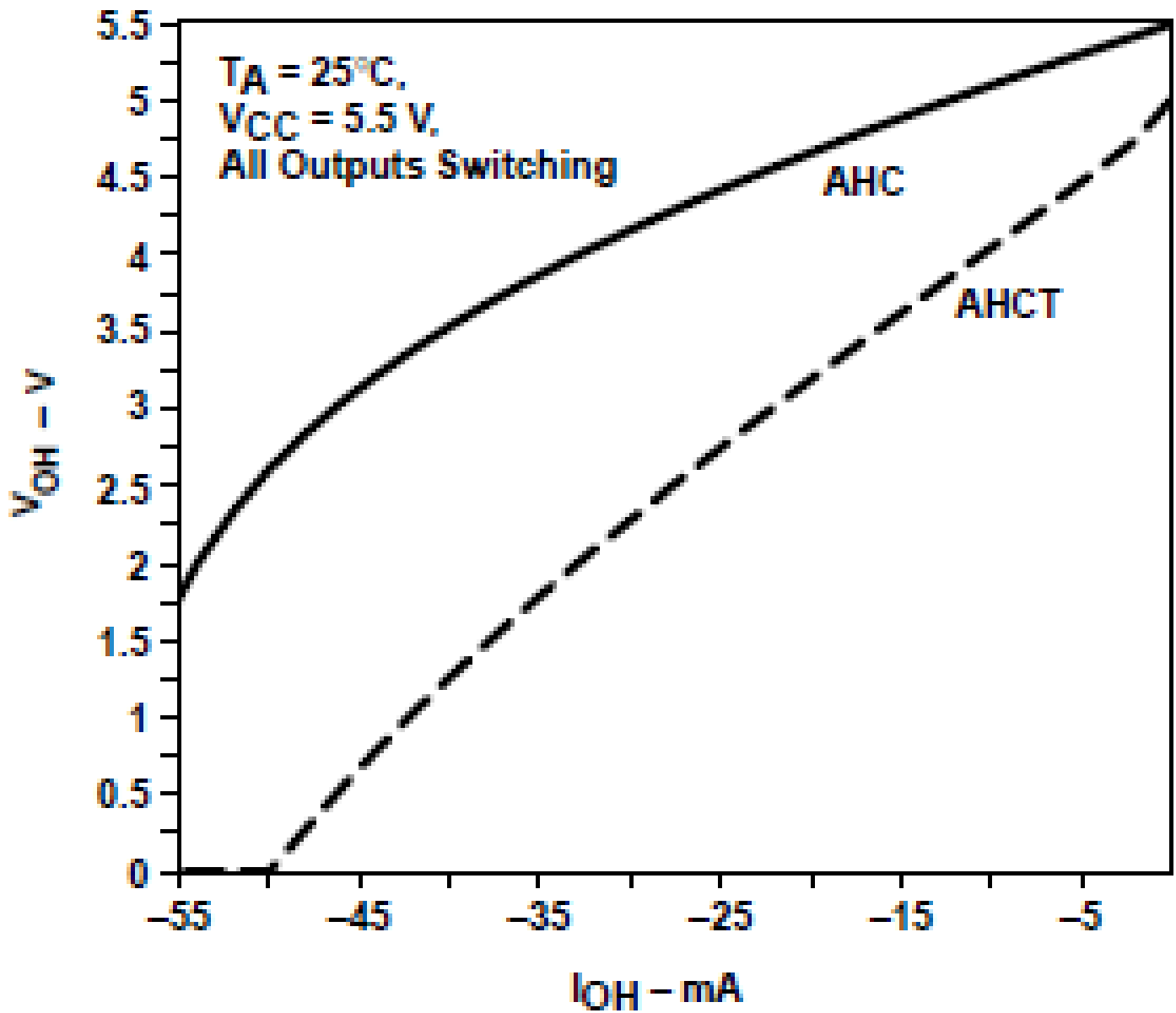

$V_{CC} = 5.5 V$

Figure 6-1. AHC Family  $V_{OL}$  vs  $I_{OL}$

## 7 Parameter Measurement Information

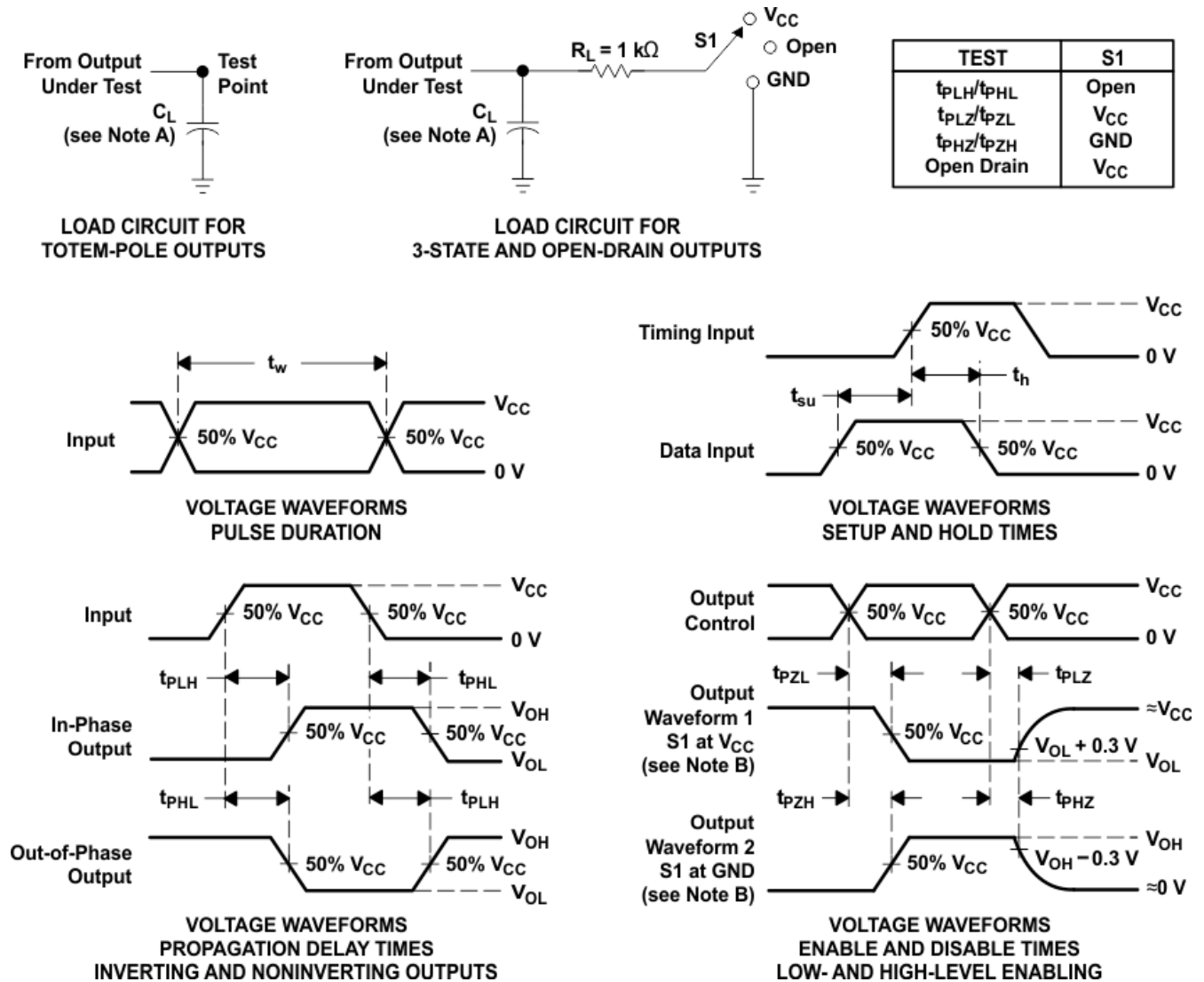

- A.  $C_L$  includes probe and jig capacitance.
- B. Waveform 1 is for an output with internal conditions such that the output is low except when disabled by the output control. Waveform 2 is for an output with internal conditions such that the output is high except when disabled by the output control.
- C. All input pulses are supplied by generators having the following characteristics:  $PRR \leq 1\text{ MHz}$ ,  $Z_O = 50\ \Omega$ ,  $t_r \leq 3\text{ ns}$ ,  $t_f \leq 3\text{ ns}$ .
- D. The outputs are measured one at a time with one input transition per measurement.
- E. All parameters and waveforms are not applicable to all devices.

Figure 7-1. Load Circuit and Voltage Waveforms

## 8 Detailed Description

### 8.1 Overview

The SNx4AHC08 devices are quadruple 2-input positive-AND gates with low drive that will produce slow rise and fall times. This slow transition reduces ringing on the output signal. The inputs are high impedance when  $V_{CC} = 0$  V.

### 8.2 Functional Block Diagram

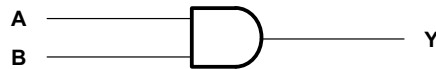

### 8.3 Feature Description

Slow rise and fall time on outputs allow for low-noise outputs.

### 8.4 Device Functional Modes

Table 8-1 is the function table for the SNx4AHC08.

**Table 8-1. Function Table  
(Each Gate)**

INPUTS		OUTPUT Y
A	B	
H	H	H
L	X	L
X	L	L

## 9 Application and Implementation

### Note

Information in the following applications sections is not part of the TI component specification, and TI does not warrant its accuracy or completeness. TI's customers are responsible for determining suitability of components for their purposes, as well as validating and testing their design implementation to confirm system functionality.

### 9.1 Application Information

A common application for AND gates is the use in power sequencing. Power sequencing is often employed in applications that require a processor or other delicate device with specific voltage timing requirements in order to protect the device from malfunctioning. Using the SN74AHC08 to verify that the processor has turned on can protect it from harmful signals.

### 9.2 Typical Application

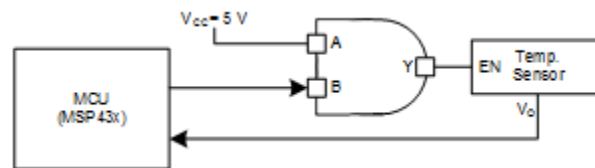

Figure 9-1. Typical Application Diagram

#### 9.2.1 Design Requirements

This device uses CMOS technology and has balanced output drive. Take care to avoid bus contention because it can drive currents that would exceed maximum limits. The high drive will also create fast edges into light loads, so routing and load conditions must be considered to prevent ringing.

#### 9.2.2 Detailed Design Procedure

1. Recommended input conditions
  - Rise time and fall time specs: See  $(\Delta t/\Delta v)$  in the [Section 6.3](#) table.
  - Specified High and low levels: See  $(V_{IH}$  and  $V_{IL})$  in the [Section 6.3](#) table.
  - Inputs are overvoltage tolerant allowing them to go as high as 5.5 V at any valid  $V_{CC}$
2. Recommend output conditions
  - Load currents should not exceed 25 mA per output and 50 mA total for the part
  - Outputs should not be pulled above  $V_{CC}$

### 9.2.3 Application Curve

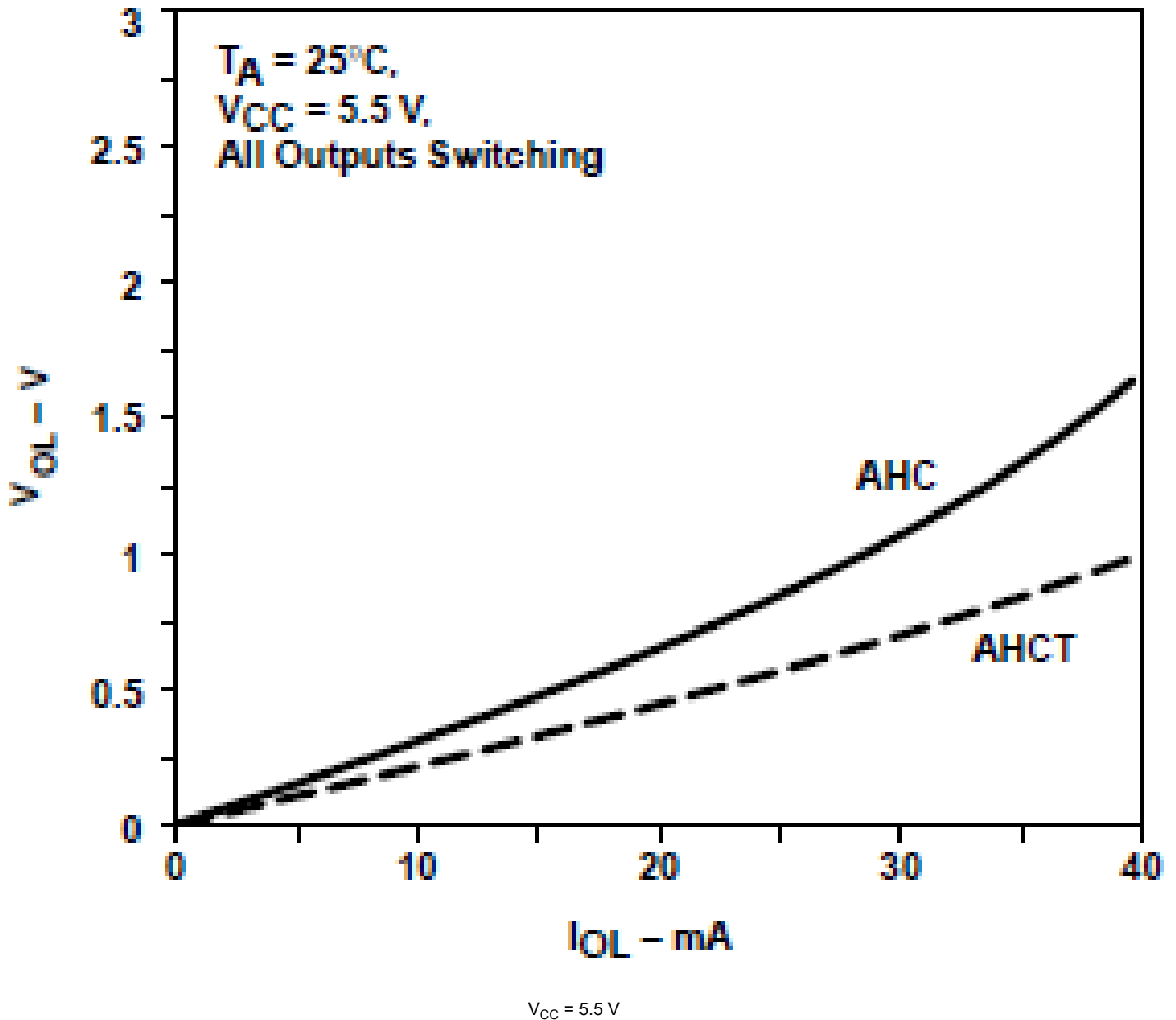

Figure 9-2. AHC Family  $V_{OH}$  vs  $I_{OH}$

### Power Supply Recommendations

The power supply can be any voltage between the minimum and maximum supply voltage rating located in the [Section 6.1](#) table.

Each  $V_{CC}$  pin should have a good bypass capacitor to prevent power disturbance. For devices with a single supply, 0.1  $\mu\text{F}$  is recommended. If there are multiple  $V_{CC}$  pins, 0.01  $\mu\text{F}$  or 0.022  $\mu\text{F}$  is recommended for each power pin. It is acceptable to parallel multiple bypass caps to reject different frequencies of noise. A 0.1  $\mu\text{F}$  and 1  $\mu\text{F}$  are commonly used in parallel. The bypass capacitor should be installed as close to the power pin as possible for best results.

## 9.3 Layout

### 9.3.1 Layout Guidelines

When using multiple bit logic devices inputs should not ever float.

In many cases, functions or parts of functions of digital logic devices are unused, for example, when only two inputs of a triple-input AND gate are used or only 3 of the 4 buffer gates are used. Such input pins should not be left unconnected because the undefined voltages at the outside connections result in undefined operational states. Specified in [Figure 9-3](#) are the rules that must be observed under all circumstances. All unused inputs of digital logic devices must be connected to a high or low bias to prevent them from floating. The logic level that must be applied to any particular unused input depends on the function of the device. Generally they will be tied to GND or  $V_{CC}$ ; whichever makes more sense or is more convenient. It is generally acceptable to float outputs unless the part is a transceiver. If the transceiver has an output enable pin, it will disable the outputs section of the part when asserted. This will not disable the input section of the IOs, so they cannot float when disabled.

#### 9.3.1.1 Layout Example

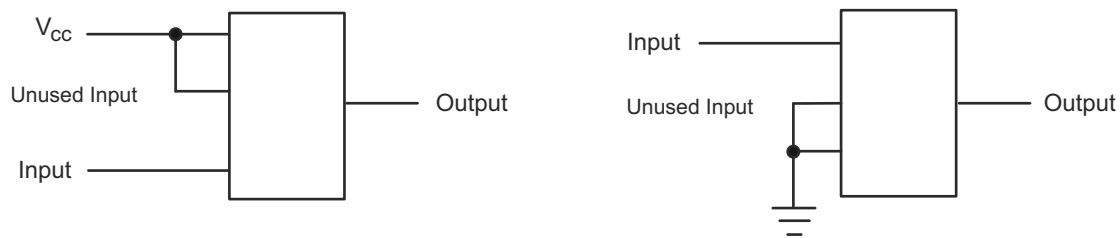

**Figure 9-3. Layout Diagram**

## 10 Device and Documentation Support

### 10.1 Documentation Support

#### 10.1.1 Related Documentation

The table below lists quick access links. Categories include technical documents, support and community resources, tools and software, and quick access to sample or buy.

**Table 10-1. Related Links**

PARTS	PRODUCT FOLDER	SAMPLE & BUY	TECHNICAL DOCUMENTS	TOOLS & SOFTWARE	SUPPORT & COMMUNITY
SN54AHC08	<a href="#">Click here</a>	<a href="#">Click here</a>	<a href="#">Click here</a>	<a href="#">Click here</a>	<a href="#">Click here</a>
SN74AHC08	<a href="#">Click here</a>	<a href="#">Click here</a>	<a href="#">Click here</a>	<a href="#">Click here</a>	<a href="#">Click here</a>

### 10.2 Receiving Notification of Documentation Updates

To receive notification of documentation updates, navigate to the device product folder on [ti.com](http://ti.com). Click on *Subscribe to updates* to register and receive a weekly digest of any product information that has changed. For change details, review the revision history included in any revised document.

### 10.3 Support Resources

[TI E2E™ support forums](#) are an engineer's go-to source for fast, verified answers and design help — straight from the experts. Search existing answers or ask your own question to get the quick design help you need.

Linked content is provided "AS IS" by the respective contributors. They do not constitute TI specifications and do not necessarily reflect TI's views; see TI's [Terms of Use](#).

### 10.4 Trademarks

TI E2E™ is a trademark of Texas Instruments.

All trademarks are the property of their respective owners.

### 10.5 Electrostatic Discharge Caution



This integrated circuit can be damaged by ESD. Texas Instruments recommends that all integrated circuits be handled with appropriate precautions. Failure to observe proper handling and installation procedures can cause damage.

ESD damage can range from subtle performance degradation to complete device failure. Precision integrated circuits may be more susceptible to damage because very small parametric changes could cause the device not to meet its published specifications.

### 10.6 Glossary

[TI Glossary](#) This glossary lists and explains terms, acronyms, and definitions.



## 11 Mechanical, Packaging, and Orderable Information

The following pages include mechanical, packaging, and orderable information. This information is the most current data available for the designated devices. This data is subject to change without notice and revision of this document. For browser-based versions of this data sheet, refer to the left-hand navigation.

**PACKAGING INFORMATION**

Orderable Device	Status (1)	Package Type	Package Drawing	Pins	Package Qty	Eco Plan (2)	Lead finish/ Ball material (6)	MSL Peak Temp (3)	Op Temp (°C)	Device Marking (4/5)	Samples
5962-9682001Q2A	ACTIVE	LCCC	FK	20	1	Non-RoHS & Green	SNPB	N / A for Pkg Type	-55 to 125	5962- 9682001Q2A SNJ54AHC 08FK	<a href="#">Samples</a>
SN74AHC08BQAR	ACTIVE	WQFN	BQA	14	3000	RoHS & Green	NIPDAU	Level-1-260C-UNLIM	-40 to 125	AHC08	<a href="#">Samples</a>
SN74AHC08DBR	ACTIVE	SSOP	DB	14	2000	RoHS & Green	NIPDAU	Level-1-260C-UNLIM	-40 to 125	HA08	<a href="#">Samples</a>
SN74AHC08DGVR	ACTIVE	TVSOP	DGV	14	2000	RoHS & Green	NIPDAU	Level-1-260C-UNLIM	-40 to 125	HA08	<a href="#">Samples</a>
SN74AHC08DR	ACTIVE	SOIC	D	14	2500	RoHS & Green	NIPDAU	Level-1-260C-UNLIM	-40 to 125	AHC08	<a href="#">Samples</a>
SN74AHC08DRG4	ACTIVE	SOIC	D	14	2500	RoHS & Green	NIPDAU	Level-1-260C-UNLIM	-40 to 125	AHC08	<a href="#">Samples</a>
SN74AHC08N	ACTIVE	PDIP	N	14	25	RoHS & Green	NIPDAU	N / A for Pkg Type	-40 to 125	SN74AHC08N	<a href="#">Samples</a>
SN74AHC08NSR	ACTIVE	SO	NS	14	2000	RoHS & Green	NIPDAU	Level-1-260C-UNLIM	-40 to 125	AHC08	<a href="#">Samples</a>
SN74AHC08PWR	ACTIVE	TSSOP	PW	14	2000	RoHS & Green	NIPDAU   SN	Level-1-260C-UNLIM	-40 to 125	HA08	<a href="#">Samples</a>
SN74AHC08PWRG4	ACTIVE	TSSOP	PW	14	2000	RoHS & Green	NIPDAU	Level-1-260C-UNLIM	-40 to 125	HA08	<a href="#">Samples</a>
SN74AHC08RGYR	ACTIVE	VQFN	RGY	14	3000	RoHS & Green	NIPDAU	Level-2-260C-1 YEAR	-40 to 125	HA08	<a href="#">Samples</a>
SNJ54AHC08FK	ACTIVE	LCCC	FK	20	1	Non-RoHS & Green	SNPB	N / A for Pkg Type	-55 to 125	5962- 9682001Q2A SNJ54AHC 08FK	<a href="#">Samples</a>

(1) The marketing status values are defined as follows:

**ACTIVE:** Product device recommended for new designs.

**LIFEBUY:** TI has announced that the device will be discontinued, and a lifetime-buy period is in effect.

**NRND:** Not recommended for new designs. Device is in production to support existing customers, but TI does not recommend using this part in a new design.

**PREVIEW:** Device has been announced but is not in production. Samples may or may not be available.

**OBSELETE:** TI has discontinued the production of the device.

(2) **RoHS:** TI defines "RoHS" to mean semiconductor products that are compliant with the current EU RoHS requirements for all 10 RoHS substances, including the requirement that RoHS substance do not exceed 0.1% by weight in homogeneous materials. Where designed to be soldered at high temperatures, "RoHS" products are suitable for use in specified lead-free processes. TI may reference these types of products as "Pb-Free".

**RoHS Exempt:** TI defines "RoHS Exempt" to mean products that contain lead but are compliant with EU RoHS pursuant to a specific EU RoHS exemption.

**Green:** TI defines "Green" to mean the content of Chlorine (Cl) and Bromine (Br) based flame retardants meet JS709B low halogen requirements of <=1000ppm threshold. Antimony trioxide based flame retardants must also meet the <=1000ppm threshold requirement.

(3) MSL, Peak Temp. - The Moisture Sensitivity Level rating according to the JEDEC industry standard classifications, and peak solder temperature.

(4) There may be additional marking, which relates to the logo, the lot trace code information, or the environmental category on the device.

(5) Multiple Device Markings will be inside parentheses. Only one Device Marking contained in parentheses and separated by a "~" will appear on a device. If a line is indented then it is a continuation of the previous line and the two combined represent the entire Device Marking for that device.

(6) Lead finish/Ball material - Orderable Devices may have multiple material finish options. Finish options are separated by a vertical ruled line. Lead finish/Ball material values may wrap to two lines if the finish value exceeds the maximum column width.

**Important Information and Disclaimer:**The information provided on this page represents TI's knowledge and belief as of the date that it is provided. TI bases its knowledge and belief on information provided by third parties, and makes no representation or warranty as to the accuracy of such information. Efforts are underway to better integrate information from third parties. TI has taken and continues to take reasonable steps to provide representative and accurate information but may not have conducted destructive testing or chemical analysis on incoming materials and chemicals. TI and TI suppliers consider certain information to be proprietary, and thus CAS numbers and other limited information may not be available for release.

In no event shall TI's liability arising out of such information exceed the total purchase price of the TI part(s) at issue in this document sold by TI to Customer on an annual basis.

**OTHER QUALIFIED VERSIONS OF SN54AHC08, SN74AHC08 :**

- Catalog : [SN74AHC08](#)
  
- Enhanced Product : [SN74AHC08-EP](#), [SN74AHC08-EP](#)
  
- Military : [SN54AHC08](#)

NOTE: Qualified Version Definitions:

- Catalog - TI's standard catalog product
  
- Enhanced Product - Supports Defense, Aerospace and Medical Applications
  
- Military - QML certified for Military and Defense Applications

**TAPE AND REEL INFORMATION**

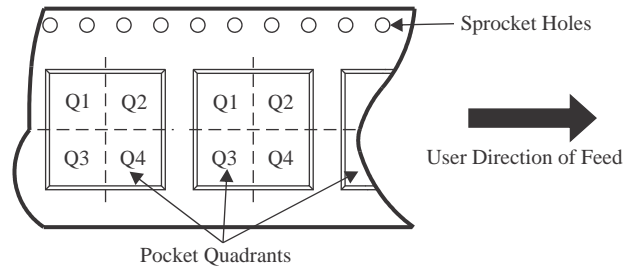
**QUADRANT ASSIGNMENTS FOR PIN 1 ORIENTATION IN TAPE**

\*All dimensions are nominal

Device	Package Type	Package Drawing	Pins	SPQ	Reel Diameter (mm)	Reel Width W1 (mm)	A0 (mm)	B0 (mm)	K0 (mm)	P1 (mm)	W (mm)	Pin1 Quadrant
SN74AHC08BQAR	WQFN	BQA	14	3000	180.0	12.4	2.8	3.3	1.1	4.0	12.0	Q1
SN74AHC08DBR	SSOP	DB	14	2000	330.0	16.4	8.35	6.6	2.4	12.0	16.0	Q1
SN74AHC08DGVR	TVSOP	DGV	14	2000	330.0	12.4	6.8	4.0	1.6	8.0	12.0	Q1
SN74AHC08DR	SOIC	D	14	2500	330.0	16.4	6.5	9.0	2.1	8.0	16.0	Q1
SN74AHC08NSR	SO	NS	14	2000	330.0	16.4	8.1	10.4	2.5	12.0	16.0	Q1
SN74AHC08PWR	TSSOP	PW	14	2000	330.0	12.4	6.9	5.6	1.6	8.0	12.0	Q1
SN74AHC08PWR	TSSOP	PW	14	2000	330.0	12.4	6.9	5.6	1.6	8.0	12.0	Q1
SN74AHC08PWRG4	TSSOP	PW	14	2000	330.0	12.4	6.9	5.6	1.6	8.0	12.0	Q1
SN74AHC08RGYR	VQFN	RGY	14	3000	330.0	12.4	3.75	3.75	1.15	8.0	12.0	Q1

**TAPE AND REEL BOX DIMENSIONS**

\*All dimensions are nominal

Device	Package Type	Package Drawing	Pins	SPQ	Length (mm)	Width (mm)	Height (mm)
SN74AHC08BQAR	WQFN	BQA	14	3000	210.0	185.0	35.0
SN74AHC08DBR	SSOP	DB	14	2000	356.0	356.0	35.0
SN74AHC08DGVR	TVSOP	DGV	14	2000	356.0	356.0	35.0
SN74AHC08DR	SOIC	D	14	2500	356.0	356.0	35.0
SN74AHC08NSR	SO	NS	14	2000	356.0	356.0	35.0
SN74AHC08PWR	TSSOP	PW	14	2000	364.0	364.0	27.0
SN74AHC08PWR	TSSOP	PW	14	2000	356.0	356.0	35.0
SN74AHC08PWRG4	TSSOP	PW	14	2000	356.0	356.0	35.0
SN74AHC08RGYR	VQFN	RGY	14	3000	356.0	356.0	35.0

**TUBE**

\*All dimensions are nominal

Device	Package Name	Package Type	Pins	SPQ	L (mm)	W (mm)	T (μm)	B (mm)
5962-9682001Q2A	FK	LCCC	20	1	506.98	12.06	2030	NA
SN74AHC08N	N	PDIP	14	25	506	13.97	11230	4.32
SN74AHC08N	N	PDIP	14	25	506	13.97	11230	4.32
SNJ54AHC08FK	FK	LCCC	20	1	506.98	12.06	2030	NA

RGY (S-PVQFN-N14)

PLASTIC QUAD FLATPACK NO-LEAD



- NOTES:
- A. All linear dimensions are in millimeters. Dimensioning and tolerancing per ASME Y14.5M-1994.
  - B. This drawing is subject to change without notice.
  - C. QFN (Quad Flatpack No-Lead) package configuration.
  - D. The package thermal pad must be soldered to the board for thermal and mechanical performance.
  - E. See the additional figure in the Product Data Sheet for details regarding the exposed thermal pad features and dimensions.
  - F. Pin 1 identifiers are located on both top and bottom of the package and within the zone indicated. The Pin 1 identifiers are either a molded, marked, or metal feature.
  - G. Package complies to JEDEC MO-241 variation BA.

RGY (S-PVQFN-N14)

PLASTIC QUAD FLATPACK NO-LEAD

**THERMAL INFORMATION**

This package incorporates an exposed thermal pad that is designed to be attached directly to an external heatsink. The thermal pad must be soldered directly to the printed circuit board (PCB). After soldering, the PCB can be used as a heatsink. In addition, through the use of thermal vias, the thermal pad can be attached directly to the appropriate copper plane shown in the electrical schematic for the device, or alternatively, can be attached to a special heatsink structure designed into the PCB. This design optimizes the heat transfer from the integrated circuit (IC).

For information on the Quad Flatpack No-Lead (QFN) package and its advantages, refer to Application Report, QFN/SON PCB Attachment, Texas Instruments Literature No. SLUA271. This document is available at [www.ti.com](http://www.ti.com).

The exposed thermal pad dimensions for this package are shown in the following illustration.



Bottom View

Exposed Thermal Pad Dimensions

4206353-2/P 03/14

NOTE: All linear dimensions are in millimeters



RGY (S-PVQFN-N14)

PLASTIC QUAD FLATPACK NO-LEAD



4208122-2/P 03/14

- NOTES:
- All linear dimensions are in millimeters.
  - This drawing is subject to change without notice.
  - Publication IPC-7351 is recommended for alternate designs.
  - This package is designed to be soldered to a thermal pad on the board. Refer to Application Note, Quad Flat-Pack QFN/SON PCB Attachment, Texas Instruments Literature No. SLUA271, and also the Product Data Sheets for specific thermal information, via requirements, and recommended board layout. These documents are available at [www.ti.com](http://www.ti.com) <<http://www.ti.com>>.
  - Laser cutting apertures with trapezoidal walls and also rounding corners will offer better paste release. Customers should contact their board assembly site for stencil design recommendations. Refer to IPC 7525 for stencil design considerations.
  - Customers should contact their board fabrication site for minimum solder mask web tolerances between signal pads.

## GENERIC PACKAGE VIEW

**BQA 14**

**WQFN - 0.8 mm max height**

2.5 x 3, 0.5 mm pitch

PLASTIC QUAD FLATPACK - NO LEAD

This image is a representation of the package family, actual package may vary.  
Refer to the product data sheet for package details.

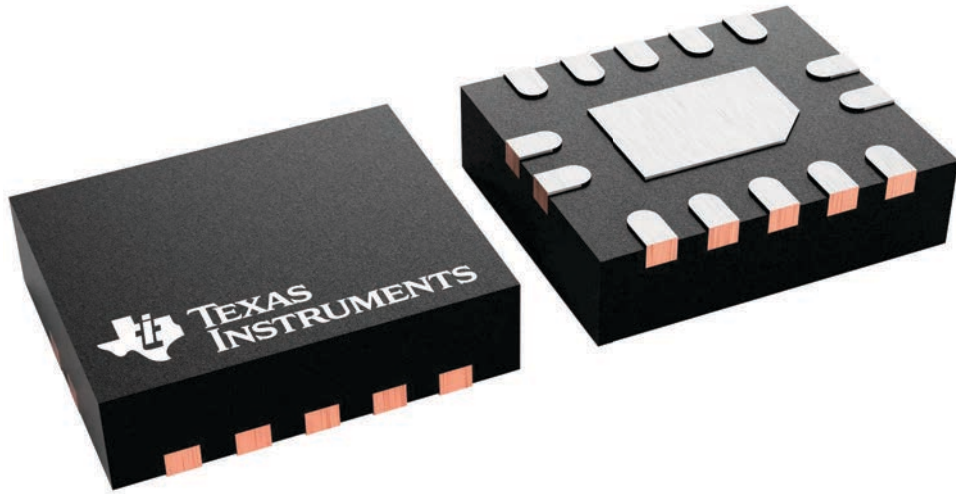

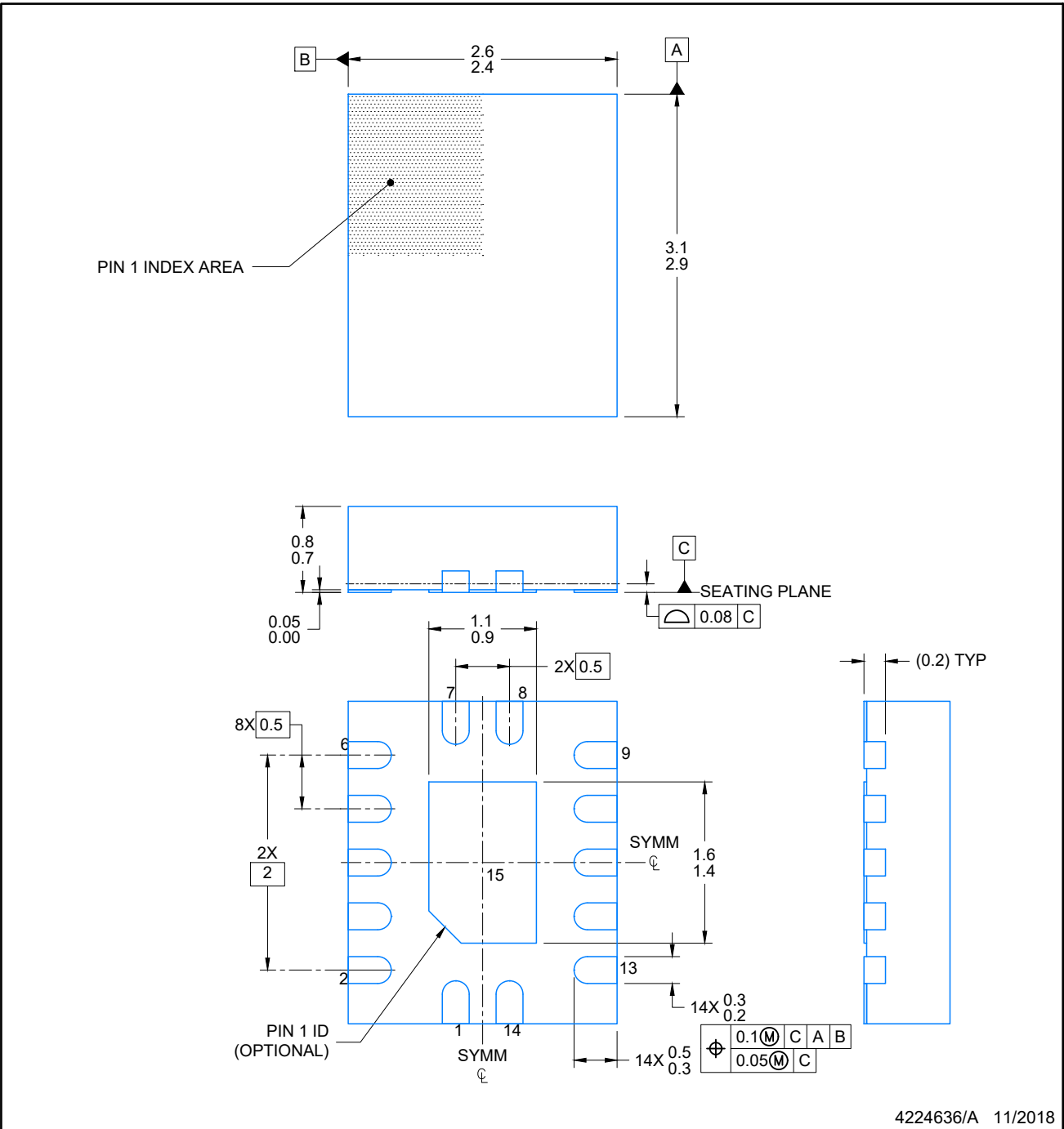

4224636/A 11/2018

**NOTES:**

- All linear dimensions are in millimeters. Any dimensions in parenthesis are for reference only. Dimensioning and tolerancing per ASME Y14.5M.
- This drawing is subject to change without notice.
- The package thermal pad must be soldered to the printed circuit board for optimal thermal and mechanical performance.

# EXAMPLE BOARD LAYOUT

WQFN - 0.8 mm max height

BQA0014A

PLASTIC QUAD FLAT PACK-NO LEAD

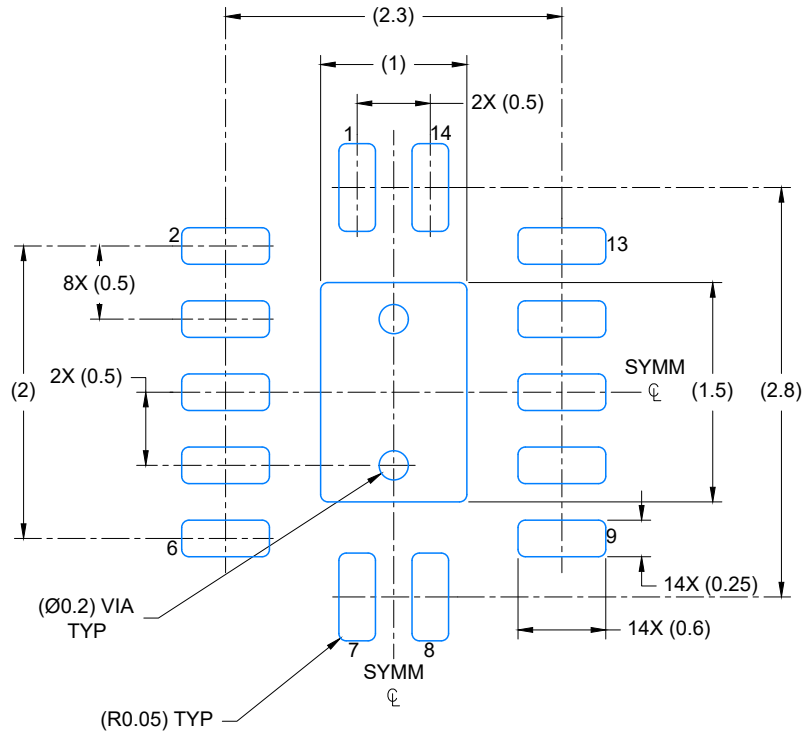

LAND PATTERN EXAMPLE  
EXPOSED METAL SHOWN  
SCALE: 20X

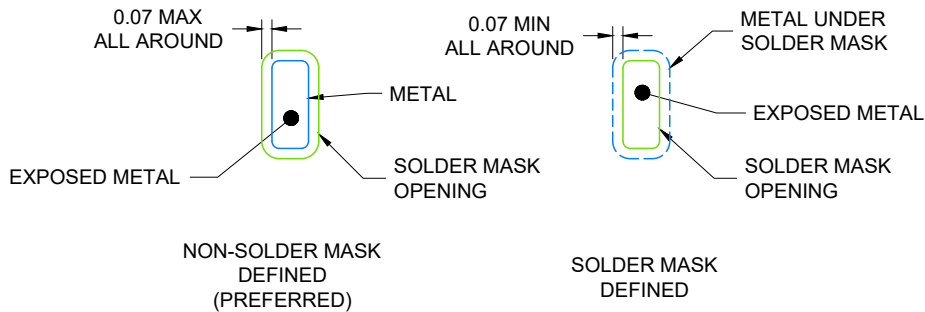

4224636/A 11/2018

NOTES: (continued)

4. This package is designed to be soldered to a thermal pad on the board. For more information, see Texas Instruments literature number SLUA271 ([www.ti.com/lit/slua271](http://www.ti.com/lit/slua271)).
5. Vias are optional depending on application, refer to device data sheet. If any vias are implemented, refer to their locations shown on this view. It is recommended that vias under paste be filled, plugged or tented.

# EXAMPLE STENCIL DESIGN

BQA0014A

WQFN - 0.8 mm max height

PLASTIC QUAD FLAT PACK-NO LEAD

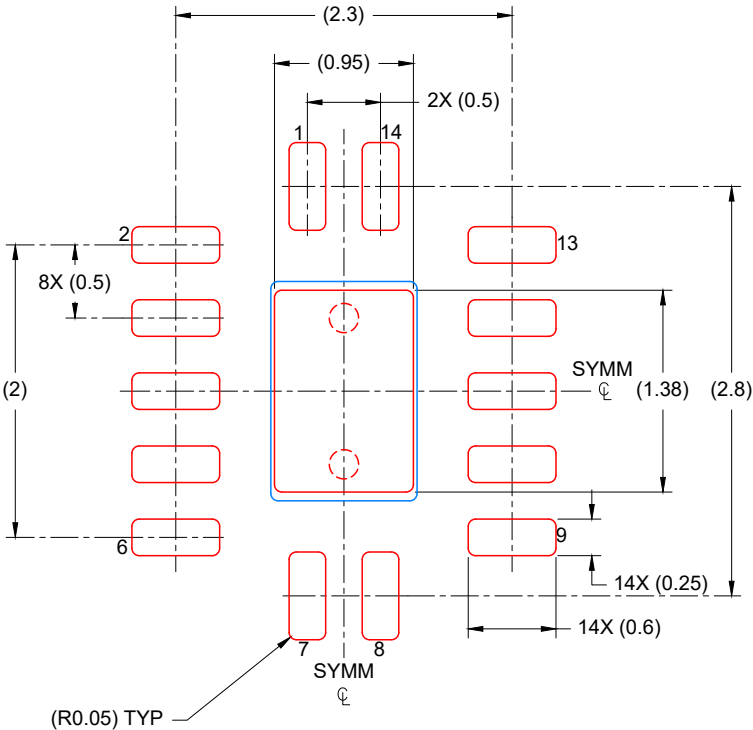

SOLDER PASTE EXAMPLE  
 BASED ON 0.125 mm THICK STENCIL

EXPOSED PAD  
 88% PRINTED COVERAGE BY AREA  
 SCALE: 20X

4224636/A 11/2018

NOTES: (continued)

- 6. Laser cutting apertures with trapezoidal walls and rounded corners may offer better paste release. IPC-7525 may have alternate design recommendations.

# MECHANICAL DATA

NS (R-PDSO-G\*\*)

PLASTIC SMALL-OUTLINE PACKAGE

14-PINS SHOWN



- NOTES:
- A. All linear dimensions are in millimeters.
  - B. This drawing is subject to change without notice.
  - C. Body dimensions do not include mold flash or protrusion, not to exceed 0,15.

DGV (R-PDSO-G\*\*)

PLASTIC SMALL-OUTLINE

24 PINS SHOWN



4073251/E 08/00

- NOTES: A. All linear dimensions are in millimeters.  
 B. This drawing is subject to change without notice.  
 C. Body dimensions do not include mold flash or protrusion, not to exceed 0,15 per side.  
 D. Falls within JEDEC: 24/48 Pins – MO-153  
 14/16/20/56 Pins – MO-194

## GENERIC PACKAGE VIEW

**FK 20**

**LCCC - 2.03 mm max height**

8.89 x 8.89, 1.27 mm pitch

LEADLESS CERAMIC CHIP CARRIER

This image is a representation of the package family, actual package may vary.  
Refer to the product data sheet for package details.



4229370VA\



D (R-PDSO-G14)

PLASTIC SMALL OUTLINE



- NOTES:
- A. All linear dimensions are in inches (millimeters).
  - B. This drawing is subject to change without notice.
  - Body length does not include mold flash, protrusions, or gate burrs. Mold flash, protrusions, or gate burrs shall not exceed 0.006 (0,15) each side.
  - Body width does not include interlead flash. Interlead flash shall not exceed 0.017 (0,43) each side.
  - E. Reference JEDEC MS-012 variation AB.

D (R-PDSO-G14)

PLASTIC SMALL OUTLINE



4211283-3/E 08/12

- NOTES:
- All linear dimensions are in millimeters.
  - This drawing is subject to change without notice.
  - Publication IPC-7351 is recommended for alternate designs.
  - Laser cutting apertures with trapezoidal walls and also rounding corners will offer better paste release. Customers should contact their board assembly site for stencil design recommendations. Refer to IPC-7525 for other stencil recommendations.
  - Customers should contact their board fabrication site for solder mask tolerances between and around signal pads.

PW (R-PDSO-G14)

PLASTIC SMALL OUTLINE

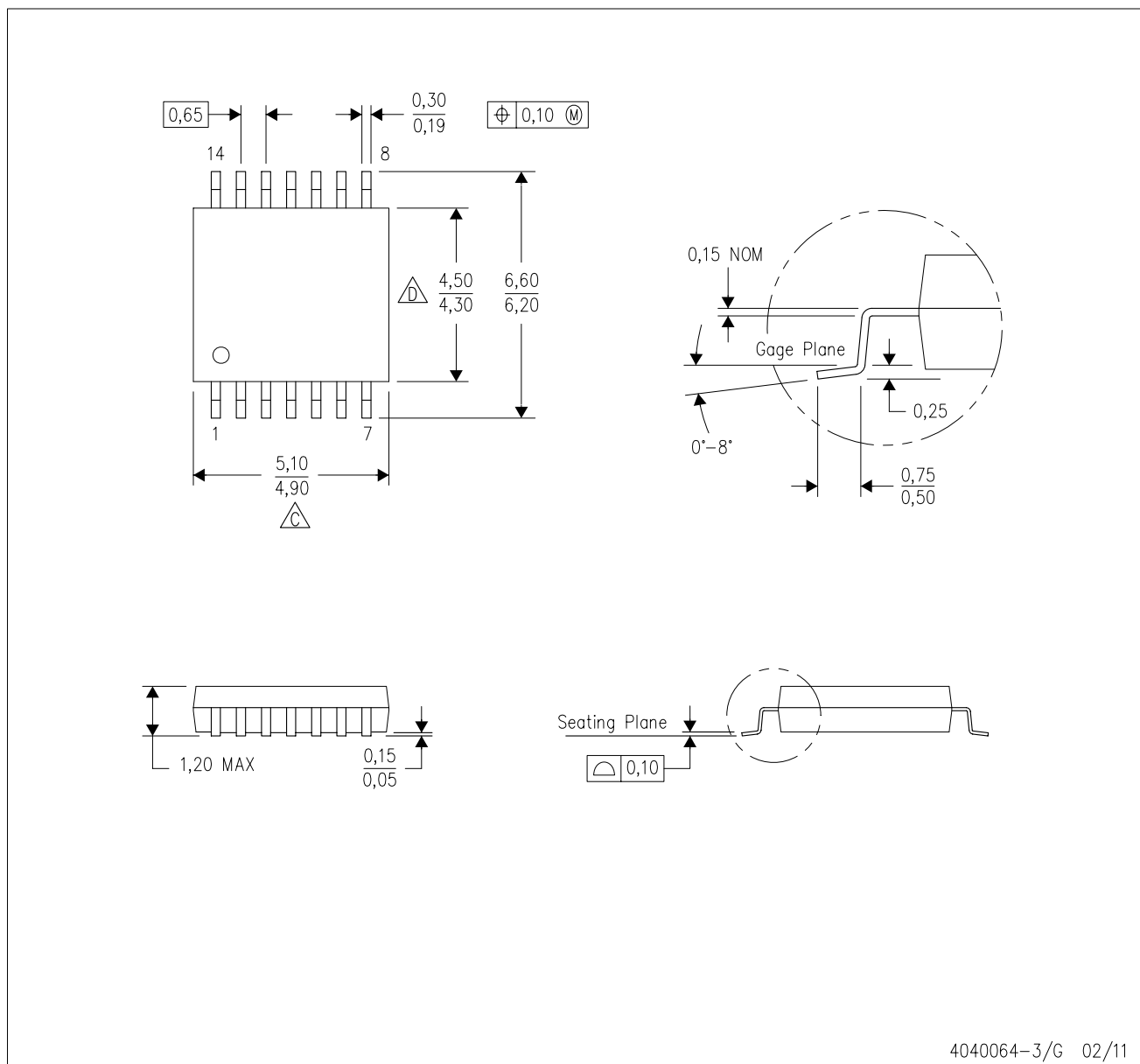

4040064-3/G 02/11

- NOTES:
- A. All linear dimensions are in millimeters. Dimensioning and tolerancing per ASME Y14.5M-1994.
  - B. This drawing is subject to change without notice.
  - C. Body length does not include mold flash, protrusions, or gate burrs. Mold flash, protrusions, or gate burrs shall not exceed 0,15 each side.
  - D. Body width does not include interlead flash. Interlead flash shall not exceed 0,25 each side.
  - E. Falls within JEDEC MO-153

PW (R-PDSO-G14)

PLASTIC SMALL OUTLINE



4211284-2/G 08/15

- NOTES:
- All linear dimensions are in millimeters.
  - This drawing is subject to change without notice.
  - Publication IPC-7351 is recommended for alternate designs.
  - Laser cutting apertures with trapezoidal walls and also rounding corners will offer better paste release. Customers should contact their board assembly site for stencil design recommendations. Refer to IPC-7525 for other stencil recommendations.
  - Customers should contact their board fabrication site for solder mask tolerances between and around signal pads.

N (R-PDIP-T\*\*)

PLASTIC DUAL-IN-LINE PACKAGE

16 PINS SHOWN



- NOTES:
- A. All linear dimensions are in inches (millimeters).
  - B. This drawing is subject to change without notice.
  - Falls within JEDEC MS-001, except 18 and 20 pin minimum body length (Dim A).
  - The 20 pin end lead shoulder width is a vendor option, either half or full width.

DB (R-PDSO-G\*\*)

PLASTIC SMALL-OUTLINE

28 PINS SHOWN



- NOTES: A. All linear dimensions are in millimeters.  
 B. This drawing is subject to change without notice.  
 C. Body dimensions do not include mold flash or protrusion not to exceed 0,15.  
 D. Falls within JEDEC MO-150

## IMPORTANT NOTICE AND DISCLAIMER

TI PROVIDES TECHNICAL AND RELIABILITY DATA (INCLUDING DATA SHEETS), DESIGN RESOURCES (INCLUDING REFERENCE DESIGNS), APPLICATION OR OTHER DESIGN ADVICE, WEB TOOLS, SAFETY INFORMATION, AND OTHER RESOURCES "AS IS" AND WITH ALL FAULTS, AND DISCLAIMS ALL WARRANTIES, EXPRESS AND IMPLIED, INCLUDING WITHOUT LIMITATION ANY IMPLIED WARRANTIES OF MERCHANTABILITY, FITNESS FOR A PARTICULAR PURPOSE OR NON-INFRINGEMENT OF THIRD PARTY INTELLECTUAL PROPERTY RIGHTS.

These resources are intended for skilled developers designing with TI products. You are solely responsible for (1) selecting the appropriate TI products for your application, (2) designing, validating and testing your application, and (3) ensuring your application meets applicable standards, and any other safety, security, regulatory or other requirements.

These resources are subject to change without notice. TI grants you permission to use these resources only for development of an application that uses the TI products described in the resource. Other reproduction and display of these resources is prohibited. No license is granted to any other TI intellectual property right or to any third party intellectual property right. TI disclaims responsibility for, and you will fully indemnify TI and its representatives against, any claims, damages, costs, losses, and liabilities arising out of your use of these resources.

TI's products are provided subject to [TI's Terms of Sale](#) or other applicable terms available either on [ti.com](https://www.ti.com) or provided in conjunction with such TI products. TI's provision of these resources does not expand or otherwise alter TI's applicable warranties or warranty disclaimers for TI products.

TI objects to and rejects any additional or different terms you may have proposed.

Mailing Address: Texas Instruments, Post Office Box 655303, Dallas, Texas 75265  
Copyright © 2023, Texas Instruments Incorporated