

LVDS QUAD DIFFERENTIAL LINE DRIVER

FEATURES

- >400 Mbps (200 MHz) Signaling Rates
- Flow-Through Pinout Simplifies PCB Layout
- 300 ps Maximum Differential Skew
- Propagation Delay Times 1.8 ns (Typical)
- 3.3 V Power Supply Design
- ± 350 mV Differential Signaling
- High Impedance on LVDS Outputs on Power Down
- Conforms to TIA/EIA-644 LVDS Standard
- Industrial Operating Temperature Range (-40°C to 85°C)
- Available in SOIC and TSSOP Packages

The SN65LVDS047 is characterized for operation from -40°C to 85°C.

**D OR PW PACKAGE
(Marked as LVDS047)
(TOP VIEW)**

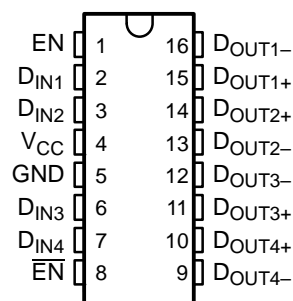

DESCRIPTION

The SN65LVDS047 is a quad differential linedriver that implements the electrical characteristics of low-voltage differential signaling (LVDS). This signaling technique lowers the output voltage levels of 5-V differential standard levels (such as EIA/TIA-422B) to reduce the power, increase the switching speeds, and allow operation with a 3.3-V supply rail. Any of the four current-mode drivers will deliver a minimum differential output voltage magnitude of 247 mV into a 100- Ω load when enabled.

The intended application of this device and signaling technique is for point-to-point and multi-drop baseband data transmission over controlled impedance media of approximately 100 Ω . The transmission media may be printed-circuit board traces, backplanes, or cables. The ultimate rate and distance of data transfer is dependent upon the attenuation characteristics of the media, the noise coupling to the environment, and other system characteristics.

functional block diagram

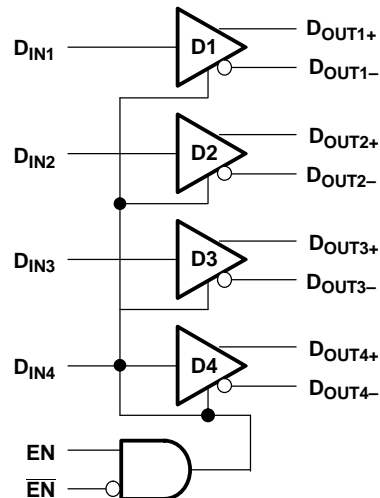

TRUTH TABLE⁽¹⁾

INPUT	ENABLES		OUTPUTS	
	D _{IN}	EN	EN̄	D _{OUT+}
L	H	L or OPEN	L	H
H			H	L
X	All other conditions		Z	Z

(1) H = high level, L = low level, X = irrelevant, Z = high impedance (off)



Please be aware that an important notice concerning availability, standard warranty, and use in critical applications of Texas Instruments semiconductor products and disclaimers thereto appears at the end of this data sheet.



These devices have limited built-in ESD protection. The leads should be shorted together or the device placed in conductive foam during storage or handling to prevent electrostatic damage to the MOS gates.

EQUIVALENT INPUT AND OUTPUT SCHEMATIC DIAGRAMS

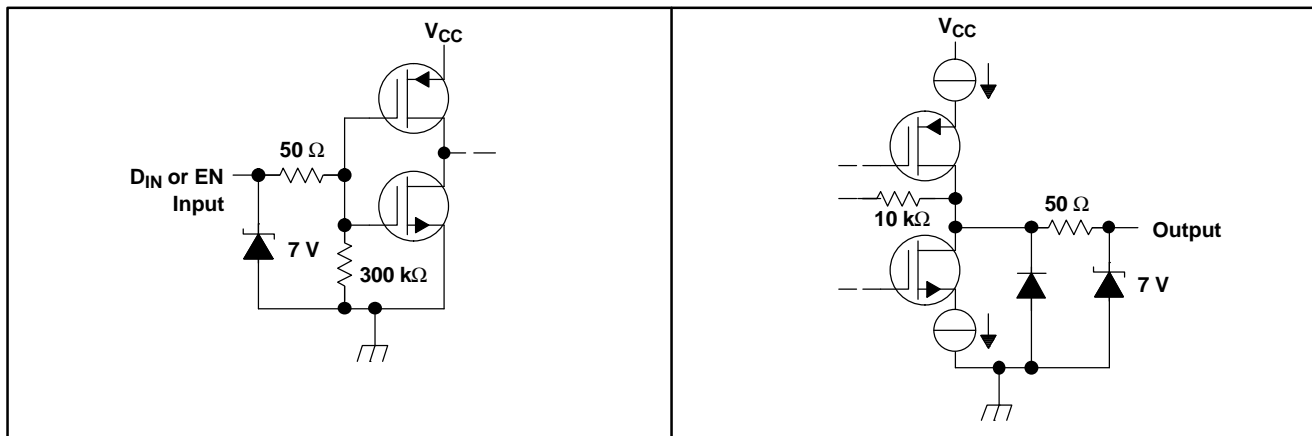

ABSOLUTE MAXIMUM RATINGS⁽¹⁾

over operating free-air temperature (see ⁽²⁾ range (unless otherwise noted)

		UNIT
(V _{CC})	Supply voltage	-0.3 V to 4 V
V _I (D _{IN})	Input voltage range	-0.3 V to (V _{CC} +0.3 V)
(EN, EN̄)	Enable input voltage	-0.3 V to (V _{CC} +0.3 V)
V _O (D _{OUT+} , D _{OUT-})	Output voltage	-0.5 V to (V _{CC} +0.5 V)
(D _{OUT+} , D _{OUT-})	Bus-pin--electrostatic discharge, see ⁽³⁾	>10 kV
(D _{OUT+} , (D _{OUT-})	Short circuit duration	Continuous
	Storage temperature range	-65°C to 150°C
	Lead temperature 1,6 mm (1/16 inch) from case for 10 seconds	260°C

- (1) Stresses beyond those listed under absolute maximum ratings may cause permanent damage to the device. These are stress ratings only, and functional operation of the device at these or any other conditions beyond those indicated under recommended operating conditions is not implied. Exposure to absolute-maximum-rated conditions for extended periods may affect device reliability.
- (2) All voltage values, except differential I/O bus voltages, are with respect to network ground terminal.
- (3) Tested in accordance with MIL-STD-883C Method 3015.7.

DISSIPATION RATING TABLE

PACKAGE	T _A ≤ 25°C POWER RATING	OPERATING FACTOR ⁽¹⁾ ABOVE T _A = 25°C	T _A = 85°C POWER RATING
D	950 mW	7.6 mW/°C	494 mW
PW	774 mW	6.2 mW/°C	402 mW

- (1) This is the inverse of the junction-to-ambient thermal resistance when board-mounted and with no air flow.

RECOMMENDED OPERATING CONDITIONS

		MIN	NOM	MAX	UNIT
V _{CC}	Supply voltage	3	3.3	3.6	V
T _A	Operating free-air temperature	-40	25	85	°C

ELECTRICAL CHARACTERISTICS

 over recommended operating free-air temperature range (see ⁽¹⁾ and ⁽²⁾) (unless otherwise noted)

PARAMETER		TEST CONDITIONS	MIN	TYP ⁽³⁾	MAX	UNIT
V_{OD}	Differential output voltage	$R_L = 100 \Omega$, see Figure 1	250	310	450	mV
$n V_{OD} $	Change in magnitude of V_{OD} for complementary output states			1	35	mV
$V_{OC(SS)}$	Steady-state, common-mode output voltage		1.125	1.17	1.375	V
$nV_{OC(SS)}$	Change in steady-state common-mode output voltage between logic states			1	25	mV
V_{OH}	Output high voltage			1.33	1.6	V
V_{OL}	Output low voltage		0.90	1.02		V
V_{IH}	Input high voltage				V_{CC}	V
V_{IL}	Input low voltage		GND	0.8	V	
I_{IH}	Input high current	$V_{IN} = V_{CC}$ or 2.5 V	-10	3	10	μ A
I_{IL}	Input low current	$V_{IN} = \text{GND}$ or 0.4 V	-10	1	10	μ A
V_{IK}	Input clamp voltage	$I_{CL} = -18 \text{ mA}$	-1.5	-0.8		V
I_{OS}	Output short circuit current, see ⁽⁴⁾	Enabled, $D_{IN} = V_{CC}$, $D_{OUT+} = 0 \text{ V}$ or $D_{IN} = \text{GND}$, $D_{OUT-} = 0 \text{ V}$		-3.1	-9	mA
I_{OSD}	Differential output short circuit current, see ⁽⁴⁾	Enabled, $V_{OD} = 0 \text{ V}$			-9	mA
I_{OFF}	Power-off leakage	$V_O = 0 \text{ V}$ or 3.6 V, $V_{CC} = 0 \text{ V}$ or Open	-1		1	μ A
I_{OZ}	Output 3-state current	$\overline{EN} = 0.8 \text{ V}$ and $\overline{EN} = 2 \text{ V}$, $V_O = 0 \text{ V}$ or V_{CC}	-1		1	μ A
I_{CC}	No load supply current, drivers enabled	$D_{IN} = V_{CC}$ or GND		7		mA
I_{CCL}	Loaded supply current, drivers enabled	$R_L = 100 \Omega$ all channels, $D_{IN} = V_{CC}$ or GND (all inputs)		20	26	mA
$I_{CC(Z)}$	No load supply current, drivers disabled	$D_{IN} = V_{CC}$ or GND, $\overline{EN} = \text{GND}$, $\overline{EN} = V_{CC}$		0.5	1.3	mA

- (1) Current into device pin is defined as positive. Current out of the device is defined as negative. All voltages are referenced to ground, unless otherwise specified.
- (2) The SN65LVDS047 is a current mode device and only functions within data sheet specifications when a resistive load is applied to the driver outputs, 90 Ω to 110 Ω typical range.
- (3) All typical values are given for: $V_{CC} = 3.3 \text{ V}$, $T_A = 25^\circ\text{C}$.
- (4) Output short circuit current (I_{OS}) is specified as magnitude only, minus sign indicates direction only.

SWITCHING CHARACTERISTICS

over recommended operating conditions (see ⁽¹⁾, ⁽²⁾ and ⁽³⁾)(unless otherwise noted)

PARAMETER		TEST CONDITIONS	MIN	TYP ⁽⁴⁾	MAX	UNIT
t_{PHL}	Differential propagation delay, high-to-low	$R_L = 100 \Omega$, $C_L = 15 \text{ pF}$, see Figure 2 and Figure 3	1.4	1.8	2.8	ns
t_{PLH}	Differential propagation delay, low-to-high		1.4	1.8	2.8	ns
$t_{SK(p)}$	Differential pulse skew ($t_{PHLD} - t_{PLHD}$), see ⁽⁵⁾			50	300	ps
$t_{SK(o)}$	Channel-to-channel skew, see ⁽⁶⁾			40	300	ps
$t_{SK(pp)}$	Differential part-to-part skew, see ⁽⁷⁾				1	ns
$t_{SK(lim)}$	Differential part-to-part skew, see ⁽⁸⁾				1.2	ns
t_r	Rise time			0.5	1.5	ns
t_f	Fall time			0.5	1.5	ns
t_{PHZ}	Disable time high to Z	$R_L = 100 \Omega$, $C_L = 15 \text{ pF}$, see Figure 4 and Figure 5		5.5	8	ns
t_{PLZ}	Disable time low to Z			5.5	8	ns
t_{PZH}	Enable time Z to high			8.5	12	ns
t_{PZL}	Enable time Z to low			8.5	12	ns
$f_{(MAX)}$	Maximum operating frequency, see ⁽⁹⁾			250		MHz

- (1) Generator waveform for all tests unless otherwise: $f = 1 \text{ MHz}$, $Z_o = 50 \Omega$, $t_r < 1 \text{ ns}$, and $t_f < 1 \text{ ns}$.
- (2) C_L includes probe and jig capacitance.
- (3) All input voltages are for one channel unless otherwise specified. Other inputs are set to GND.
- (4) All typical values are given for: $V_{CC} = 3.3 \text{ V}$, $T_A = 25^\circ\text{C}$.
- (5) $t_{SK(p)} |t_{PHL} - t_{PLH}|$ is the magnitude difference in differential propagation delay time between the positive going edge and the negative going edge of the same channel.
- (6) $t_{SK(o)}$ is the differential channel-to-channel skew of any event on the same device.
- (7) $t_{SK(pp)}$ is the differential part-to-part skew, and is defined as the difference between the minimum and the maximum specified differential propagation delays. This specification applies to devices at the same V_{CC} and within 5°C of each other within the operating temperature range.
- (8) $t_{SK(lim)}$ part-to-part skew, is the differential channel-to-channel skew of any event between devices. This specification applies to devices over recommended operating temperature and voltage ranges, and across process distribution. $t_{SK(lim)}$ is defined as $|\text{Min} - \text{Max}|$ differential propagation delay.
- (9) $f_{(MAX)}$ generator input conditions: $t_r = t_f < 1 \text{ ns}$ (0% to 100%), 50% duty cycle, 0 V to 3 V. Output criteria: duty cycle = 45% to 55%, $V_{OD} > 250 \text{ mV}$, all channels switching

PARAMETER MEASUREMENT INFORMATION

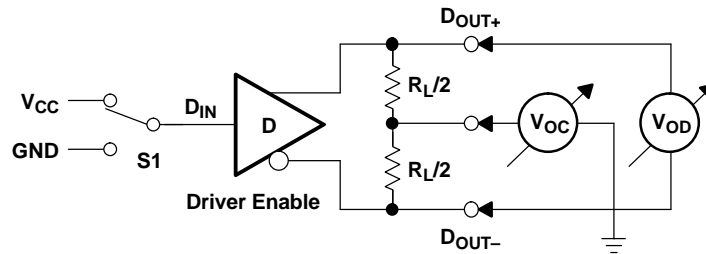

Figure 1. Driver V_{OD} and V_{OC} Test Circuit

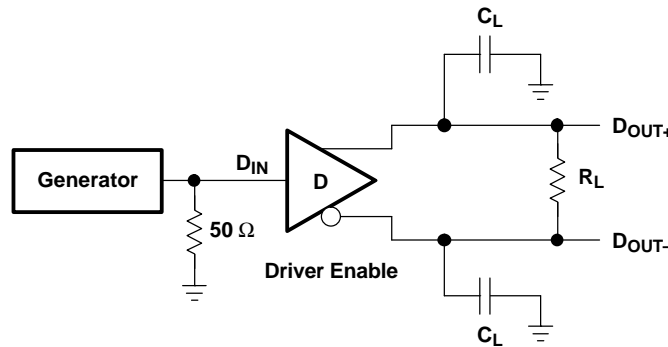

Figure 2. Driver Propagation Delay and Transition Time Test Circuit

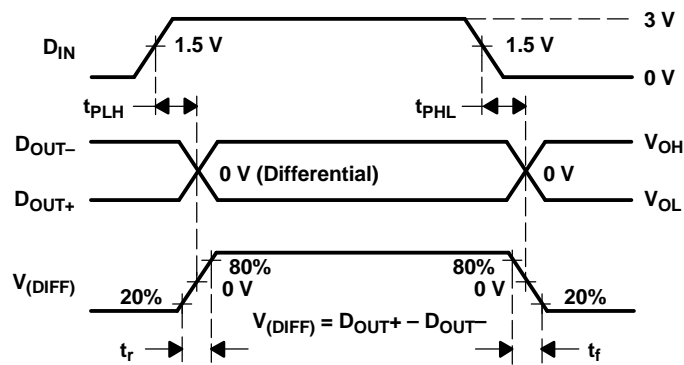

Figure 3. Driver Propagation Delay and Transition Time Waveforms

PARAMETER MEASUREMENT INFORMATION (continued)

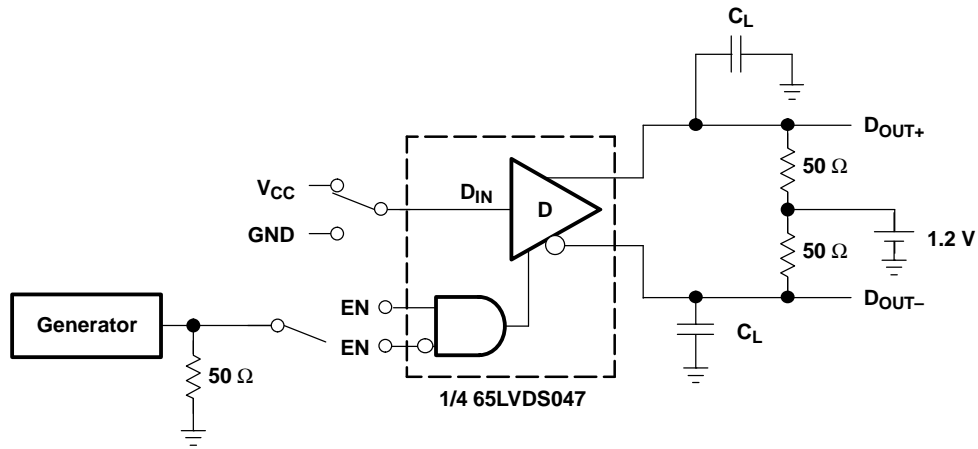

Figure 4. Driver 3-State Delay Test Circuit

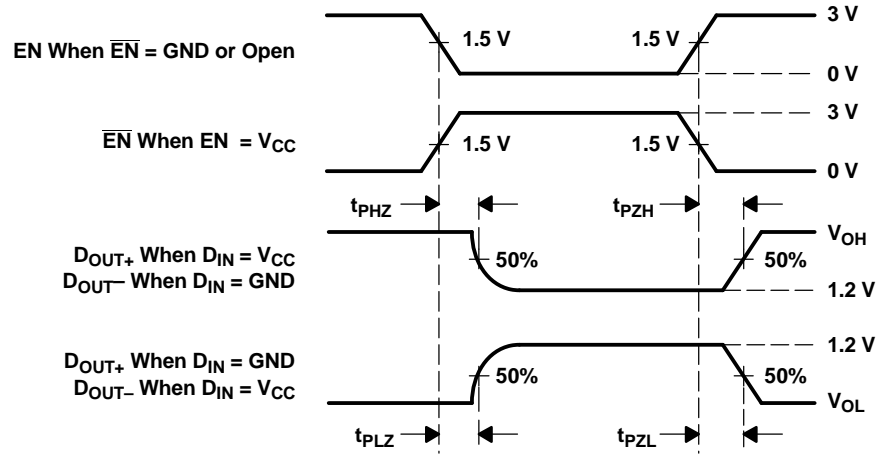

Figure 5. Driver 3-State Delay Waveform

TYPICAL CHARACTERISTICS

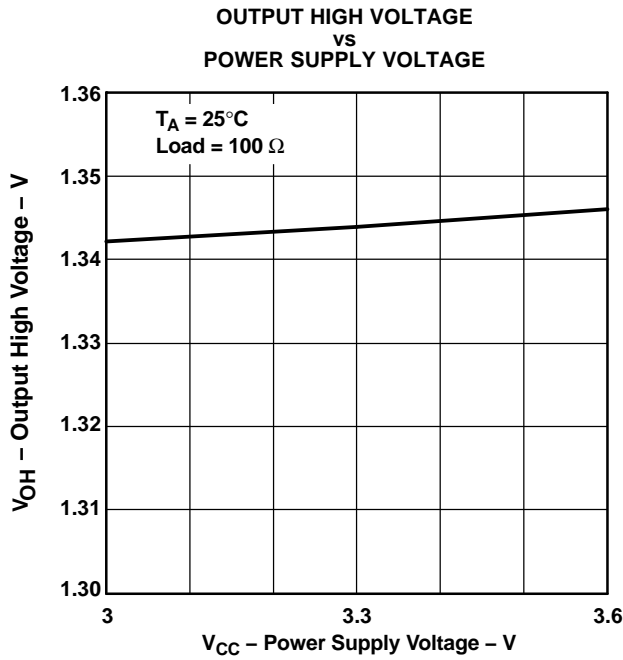

Figure 6.

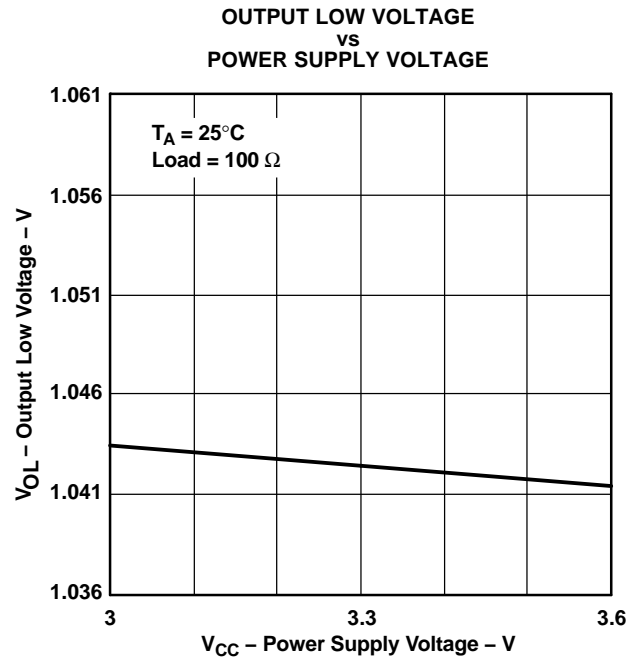

Figure 7.

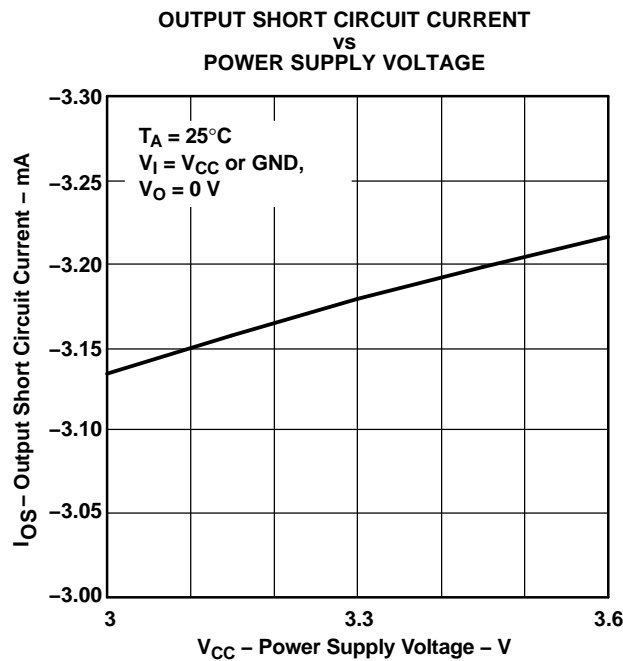

Figure 8.

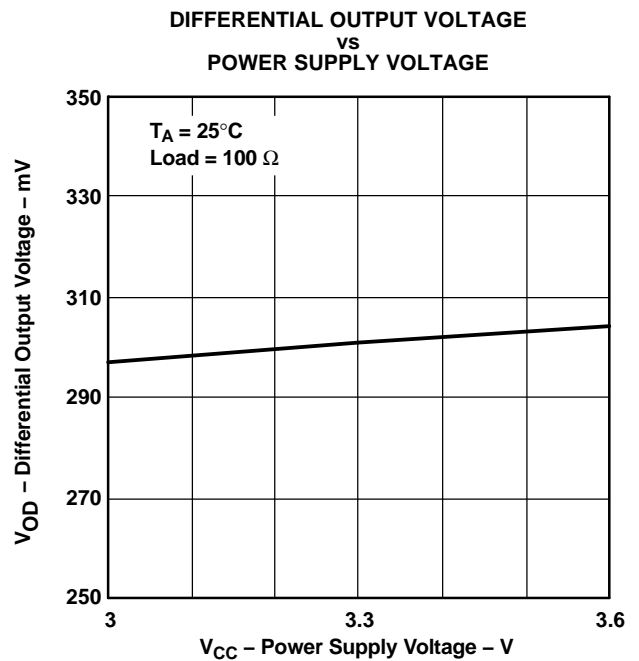

Figure 9.

TYPICAL CHARACTERISTICS (continued)

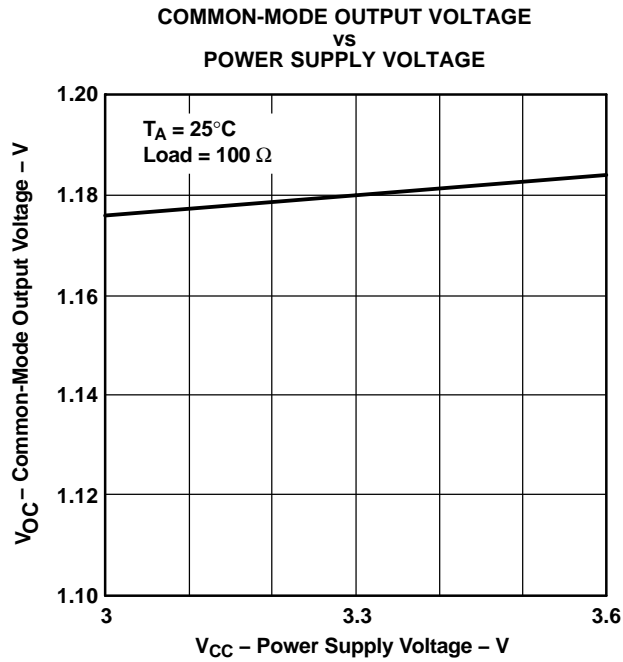

Figure 10.

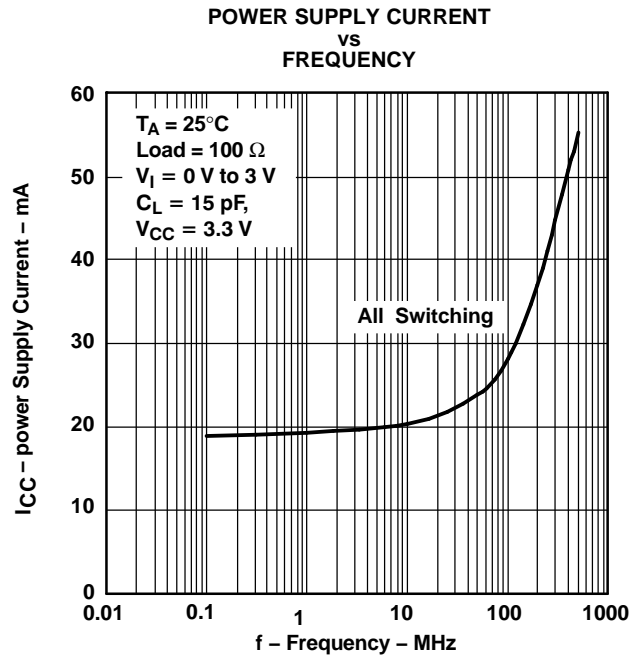

Figure 11.

PACKAGING INFORMATION

Orderable Device	Status ⁽¹⁾	Package Type	Package Drawing	Pins	Package Qty	Eco Plan ⁽²⁾	Lead/Ball Finish	MSL Peak Temp ⁽³⁾
SN65LVDS047D	ACTIVE	SOIC	D	16	40	Green (RoHS & no Sb/Br)	CU NIPDAU	Level-1-260C-UNLIM
SN65LVDS047DG4	ACTIVE	SOIC	D	16	40	Green (RoHS & no Sb/Br)	CU NIPDAU	Level-1-260C-UNLIM
SN65LVDS047DR	ACTIVE	SOIC	D	16	2500	Green (RoHS & no Sb/Br)	CU NIPDAU	Level-1-260C-UNLIM
SN65LVDS047DRG4	ACTIVE	SOIC	D	16	2500	Green (RoHS & no Sb/Br)	CU NIPDAU	Level-1-260C-UNLIM
SN65LVDS047PW	ACTIVE	TSSOP	PW	16	90	Green (RoHS & no Sb/Br)	CU NIPDAU	Level-1-260C-UNLIM
SN65LVDS047PWG4	ACTIVE	TSSOP	PW	16	90	Green (RoHS & no Sb/Br)	CU NIPDAU	Level-1-260C-UNLIM
SN65LVDS047PWR	ACTIVE	TSSOP	PW	16	2000	Green (RoHS & no Sb/Br)	CU NIPDAU	Level-1-260C-UNLIM
SN65LVDS047PWRG4	ACTIVE	TSSOP	PW	16	2000	Green (RoHS & no Sb/Br)	CU NIPDAU	Level-1-260C-UNLIM

⁽¹⁾ The marketing status values are defined as follows:

ACTIVE: Product device recommended for new designs.

LIFEBUY: TI has announced that the device will be discontinued, and a lifetime-buy period is in effect.

NRND: Not recommended for new designs. Device is in production to support existing customers, but TI does not recommend using this part in a new design.

PREVIEW: Device has been announced but is not in production. Samples may or may not be available.

OBSOLETE: TI has discontinued the production of the device.

⁽²⁾ Eco Plan - The planned eco-friendly classification: Pb-Free (RoHS), Pb-Free (RoHS Exempt), or Green (RoHS & no Sb/Br) - please check <http://www.ti.com/productcontent> for the latest availability information and additional product content details.

TBD: The Pb-Free/Green conversion plan has not been defined.

Pb-Free (RoHS): TI's terms "Lead-Free" or "Pb-Free" mean semiconductor products that are compatible with the current RoHS requirements for all 6 substances, including the requirement that lead not exceed 0.1% by weight in homogeneous materials. Where designed to be soldered at high temperatures, TI Pb-Free products are suitable for use in specified lead-free processes.

Pb-Free (RoHS Exempt): This component has a RoHS exemption for either 1) lead-based flip-chip solder bumps used between the die and package, or 2) lead-based die adhesive used between the die and leadframe. The component is otherwise considered Pb-Free (RoHS compatible) as defined above.

Green (RoHS & no Sb/Br): TI defines "Green" to mean Pb-Free (RoHS compatible), and free of Bromine (Br) and Antimony (Sb) based flame retardants (Br or Sb do not exceed 0.1% by weight in homogeneous material)

⁽³⁾ MSL, Peak Temp. -- The Moisture Sensitivity Level rating according to the JEDEC industry standard classifications, and peak solder temperature.

Important Information and Disclaimer:The information provided on this page represents TI's knowledge and belief as of the date that it is provided. TI bases its knowledge and belief on information provided by third parties, and makes no representation or warranty as to the accuracy of such information. Efforts are underway to better integrate information from third parties. TI has taken and continues to take reasonable steps to provide representative and accurate information but may not have conducted destructive testing or chemical analysis on incoming materials and chemicals. TI and TI suppliers consider certain information to be proprietary, and thus CAS numbers and other limited information may not be available for release.

In no event shall TI's liability arising out of such information exceed the total purchase price of the TI part(s) at issue in this document sold by TI to Customer on an annual basis.

TAPE AND REEL INFORMATION

QUADRANT ASSIGNMENTS FOR PIN 1 ORIENTATION IN TAPE

*All dimensions are nominal

Device	Package Type	Package Drawing	Pins	SPQ	Reel Diameter (mm)	Reel Width W1 (mm)	A0 (mm)	B0 (mm)	K0 (mm)	P1 (mm)	W (mm)	Pin1 Quadrant
SN65LVDS047DR	SOIC	D	16	2500	330.0	16.4	6.5	10.3	2.1	8.0	16.0	Q1
SN65LVDS047PWR	TSSOP	PW	16	2000	330.0	12.4	6.9	5.6	1.6	8.0	12.0	Q1

TAPE AND REEL BOX DIMENSIONS

*All dimensions are nominal



Device	Package Type	Package Drawing	Pins	SPQ	Length (mm)	Width (mm)	Height (mm)
SN65LVDS047DR	SOIC	D	16	2500	346.0	346.0	33.0
SN65LVDS047PWR	TSSOP	PW	16	2000	346.0	346.0	29.0

D (R-PDSO-G16)

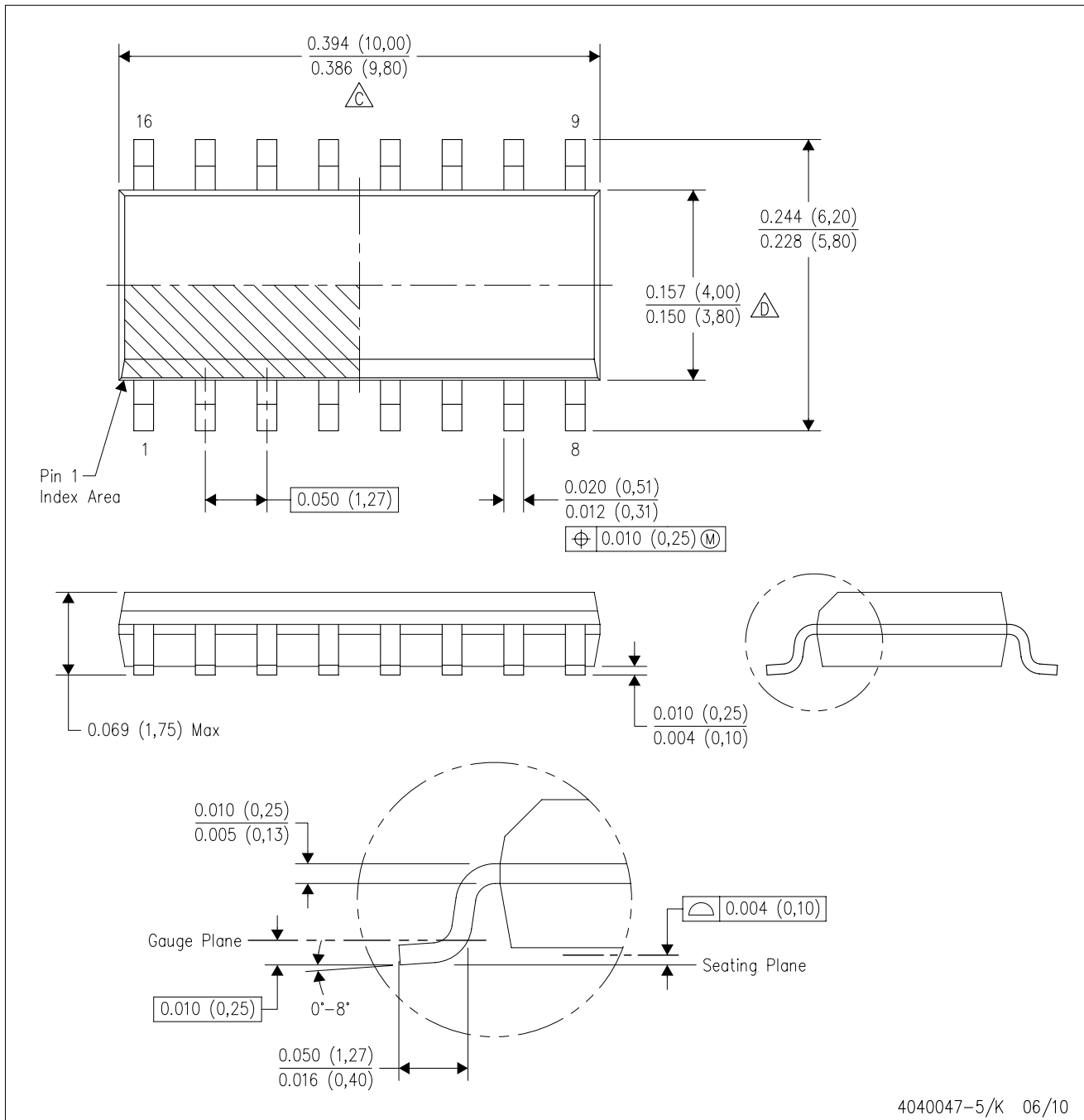
PLASTIC SMALL-OUTLINE PACKAGE



4040047-5/K 06/10

- NOTES:
- A. All linear dimensions are in inches (millimeters).
 - B. This drawing is subject to change without notice.
 -  C. Body length does not include mold flash, protrusions, or gate burrs. Mold flash, protrusions, or gate burrs shall not exceed .006 (0,15) per end.
 -  D. Body width does not include interlead flash. Interlead flash shall not exceed .017 (0,43) per side.
 - E. Reference JEDEC MS-012 variation AC.

D (R-PDSO-G16)

PLASTIC SMALL OUTLINE

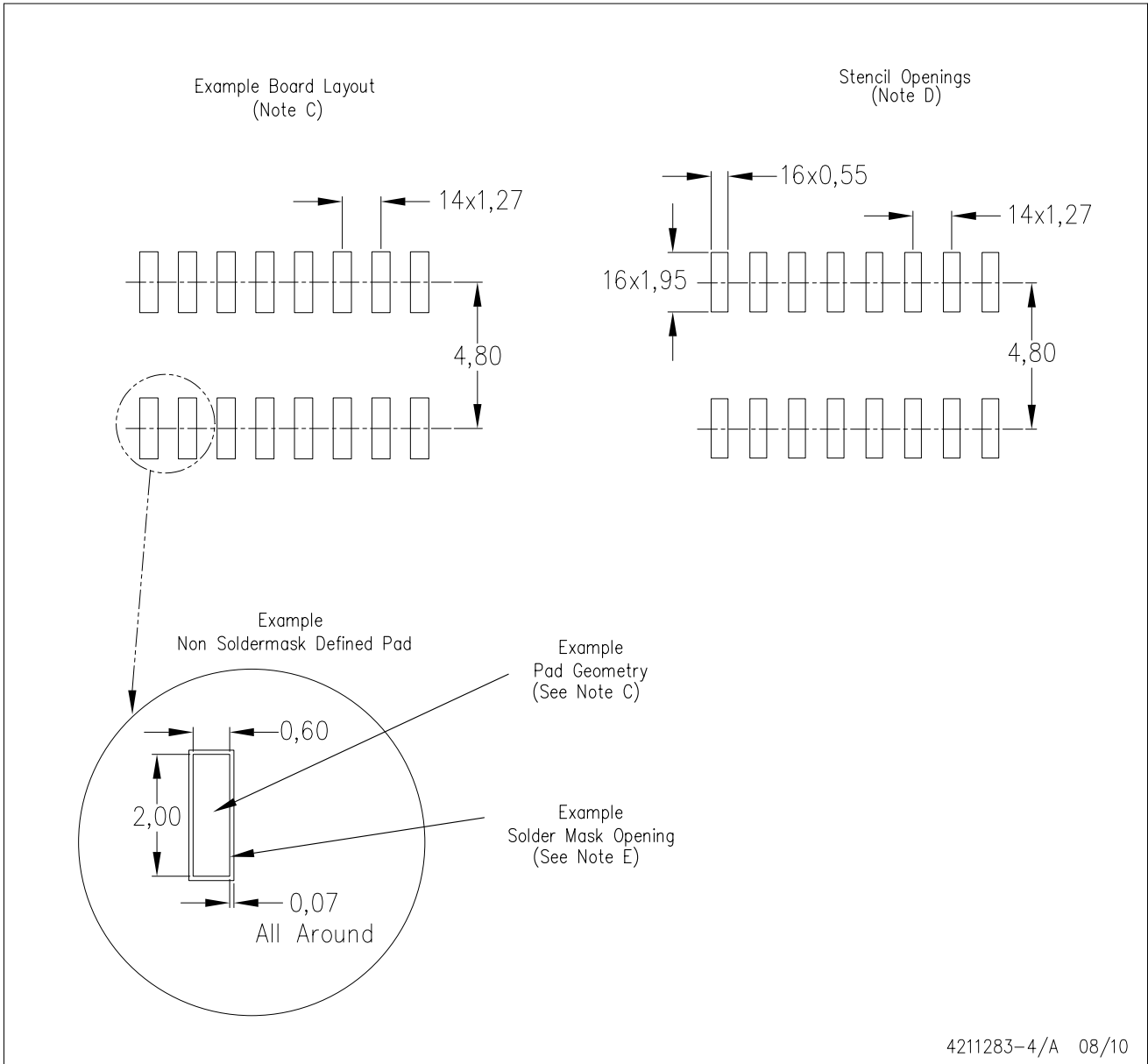

- NOTES:
- A. All linear dimensions are in millimeters.
 - B. This drawing is subject to change without notice.
 - C. Publication IPC-7351 is recommended for alternate designs.
 - D. Laser cutting apertures with trapezoidal walls and also rounding corners will offer better paste release. Customers should contact their board assembly site for stencil design recommendations. Refer to IPC-7525 for other stencil recommendations.
 - E. Customers should contact their board fabrication site for solder mask tolerances between and around signal pads.

PW (R-PDSO-G**)

PLASTIC SMALL-OUTLINE PACKAGE

14 PINS SHOWN



4040064/F 01/97

- NOTES: A. All linear dimensions are in millimeters.
 B. This drawing is subject to change without notice.
 C. Body dimensions do not include mold flash or protrusion not to exceed 0,15.
 D. Falls within JEDEC MO-153

PW (R-PDSO-G16)

PLASTIC SMALL OUTLINE

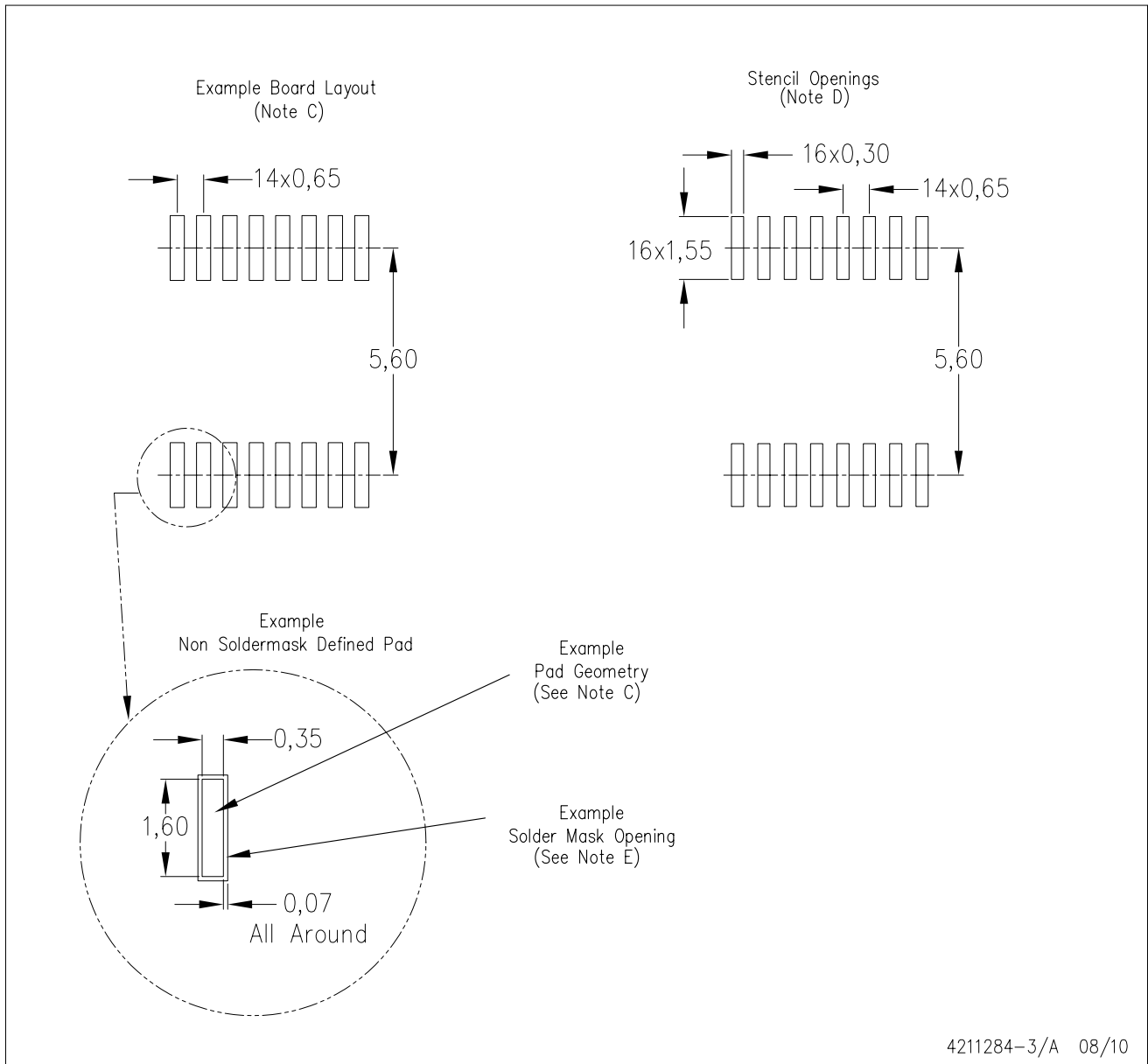

- NOTES:
- All linear dimensions are in millimeters.
 - This drawing is subject to change without notice.
 - Publication IPC-7351 is recommended for alternate designs.
 - Laser cutting apertures with trapezoidal walls and also rounding corners will offer better paste release. Customers should contact their board assembly site for stencil design recommendations. Refer to IPC-7525 for other stencil recommendations.
 - Customers should contact their board fabrication site for solder mask tolerances between and around signal pads.

IMPORTANT NOTICE

Texas Instruments Incorporated and its subsidiaries (TI) reserve the right to make corrections, modifications, enhancements, improvements, and other changes to its products and services at any time and to discontinue any product or service without notice. Customers should obtain the latest relevant information before placing orders and should verify that such information is current and complete. All products are sold subject to TI's terms and conditions of sale supplied at the time of order acknowledgment.

TI warrants performance of its hardware products to the specifications applicable at the time of sale in accordance with TI's standard warranty. Testing and other quality control techniques are used to the extent TI deems necessary to support this warranty. Except where mandated by government requirements, testing of all parameters of each product is not necessarily performed.

TI assumes no liability for applications assistance or customer product design. Customers are responsible for their products and applications using TI components. To minimize the risks associated with customer products and applications, customers should provide adequate design and operating safeguards.

TI does not warrant or represent that any license, either express or implied, is granted under any TI patent right, copyright, mask work right, or other TI intellectual property right relating to any combination, machine, or process in which TI products or services are used. Information published by TI regarding third-party products or services does not constitute a license from TI to use such products or services or a warranty or endorsement thereof. Use of such information may require a license from a third party under the patents or other intellectual property of the third party, or a license from TI under the patents or other intellectual property of TI.

Reproduction of TI information in TI data books or data sheets is permissible only if reproduction is without alteration and is accompanied by all associated warranties, conditions, limitations, and notices. Reproduction of this information with alteration is an unfair and deceptive business practice. TI is not responsible or liable for such altered documentation. Information of third parties may be subject to additional restrictions.

Resale of TI products or services with statements different from or beyond the parameters stated by TI for that product or service voids all express and any implied warranties for the associated TI product or service and is an unfair and deceptive business practice. TI is not responsible or liable for any such statements.

TI products are not authorized for use in safety-critical applications (such as life support) where a failure of the TI product would reasonably be expected to cause severe personal injury or death, unless officers of the parties have executed an agreement specifically governing such use. Buyers represent that they have all necessary expertise in the safety and regulatory ramifications of their applications, and acknowledge and agree that they are solely responsible for all legal, regulatory and safety-related requirements concerning their products and any use of TI products in such safety-critical applications, notwithstanding any applications-related information or support that may be provided by TI. Further, Buyers must fully indemnify TI and its representatives against any damages arising out of the use of TI products in such safety-critical applications.

TI products are neither designed nor intended for use in military/aerospace applications or environments unless the TI products are specifically designated by TI as military-grade or "enhanced plastic." Only products designated by TI as military-grade meet military specifications. Buyers acknowledge and agree that any such use of TI products which TI has not designated as military-grade is solely at the Buyer's risk, and that they are solely responsible for compliance with all legal and regulatory requirements in connection with such use.

TI products are neither designed nor intended for use in automotive applications or environments unless the specific TI products are designated by TI as compliant with ISO/TS 16949 requirements. Buyers acknowledge and agree that, if they use any non-designated products in automotive applications, TI will not be responsible for any failure to meet such requirements.

Following are URLs where you can obtain information on other Texas Instruments products and application solutions:

Products		Applications	
Amplifiers	amplifier.ti.com	Audio	www.ti.com/audio
Data Converters	dataconverter.ti.com	Automotive	www.ti.com/automotive
DLP® Products	www.dlp.com	Communications and Telecom	www.ti.com/communications
DSP	dsp.ti.com	Computers and Peripherals	www.ti.com/computers
Clocks and Timers	www.ti.com/clocks	Consumer Electronics	www.ti.com/consumer-apps
Interface	interface.ti.com	Energy	www.ti.com/energy
Logic	logic.ti.com	Industrial	www.ti.com/industrial
Power Mgmt	power.ti.com	Medical	www.ti.com/medical
Microcontrollers	microcontroller.ti.com	Security	www.ti.com/security
RFID	www.ti-rfid.com	Space, Avionics & Defense	www.ti.com/space-avionics-defense
RF/IF and ZigBee® Solutions	www.ti.com/lprf	Video and Imaging	www.ti.com/video
		Wireless	www.ti.com/wireless-apps

Mailing Address: Texas Instruments, Post Office Box 655303, Dallas, Texas 75265
Copyright © 2010, Texas Instruments Incorporated