

SN65LBC175A, SN75LBC175A QUADRUPLE RS-485 DIFFERENTIAL LINE RECEIVERS

SLLS455B – NOVEMBER 2000 – REVISED MARCH 2005

- Designed for TIA/EIA-485, TIA/EIA-422, and ISO 8482 Applications
- Signaling Rate¹ Exceeding 50 Mbps
- Fail-Safe in Bus Short-Circuit, Open-Circuit, and Idle-Bus Conditions
- ESD Protection on Bus Inputs Exceeds 6 kV
- Common-Mode Bus Input Range –7 V to 12 V
- Propagation Delay Times <16 ns
- Low Standby Power Consumption <20 μ A
- Pin-Compatible Upgrade for MC3486, DS96F175, LTC489, and SN75175

SN65LBC175A (Marked as 65LBC175A)
SN75LBC175A (Marked as 75LBC175A)
D or N PACKAGE
(TOP VIEW)

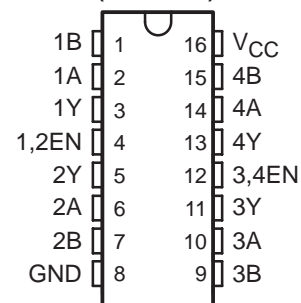

logic diagram

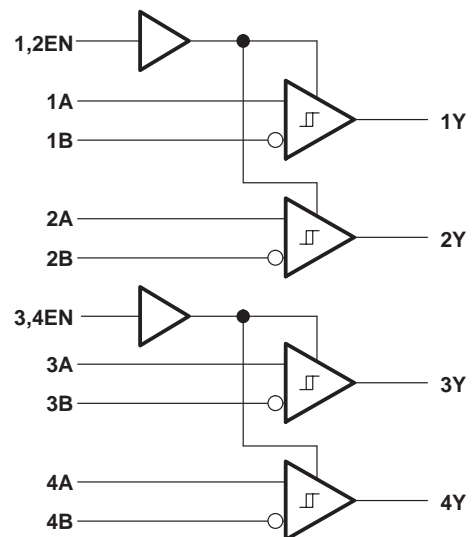

description

The SN65LBC175A and SN75LBC175A are quadruple differential line receivers with 3-state outputs, designed for TIA/EIA-485 (RS-485), TIA/EIA-422 (RS-422), and ISO 8482 (Euro RS-485) applications.

These devices are optimized for balanced multipoint bus communication at data rates up to and exceeding 50 million bits per second. The transmission media may be twisted-pair cables, printed-circuit board traces, or backplanes. The ultimate rate and distance of data transfer is dependent upon the attenuation characteristics of the media and the noise coupling to the environment.

Each receiver operates over a wide range of positive and negative common-mode input voltages, and features ESD protection to 6 kV, making it suitable for high-speed multipoint data transmission applications in harsh environments. These devices are designed using LinBiCMOS™, facilitating low power consumption and inherent robustness.

Two EN inputs provide pair-wise enable control, or these can be tied together externally to enable all four drivers with the same signal.

The SN75LBC175A is characterized for operation over the temperature range of 0°C to 70°C. The SN65LBC175A is characterized over the temperature range from –40°C to 85°C.



Please be aware that an important notice concerning availability, standard warranty, and use in critical applications of Texas Instruments semiconductor products and disclaimers thereto appears at the end of this data sheet.

LinBiCMOS is a trademark of Texas Instruments.

¹The signaling rate of a line is the number of voltage transitions that are made per second expressed in the units bps (bits per second).

PRODUCTION DATA information is current as of publication date. Products conform to specifications per the terms of Texas Instruments standard warranty. Production processing does not necessarily include testing of all parameters.

 **TEXAS
INSTRUMENTS**

POST OFFICE BOX 655303 • DALLAS, TEXAS 75265

Copyright © 2001, Texas Instruments Incorporated

SN65LBC175A, SN75LBC175A QUADRUPLE RS-485 DIFFERENTIAL LINE RECEIVERS

SLLS455B – NOVEMBER 2000 – REVISED MARCH 2005

FUNCTION TABLE
(each receiver)

DIFFERENTIAL INPUTS A – B (V_{ID})	ENABLE EN	OUTPUT Y
$V_{ID} \leq -0.2 \text{ V}$	H	L
$-0.2 \text{ V} < V_{ID} < -0.01 \text{ V}$	H	?
$-0.01 \text{ V} \leq V_{ID}$	H	H
X	L	Z
X	OPEN	Z
Short circuit	H	H
Open circuit	H	H

H = high level, L = low level, X = irrelevant, Z = high impedance (off),
? = indeterminate

AVAILABLE OPTIONS

TA	PACKAGE	
	PLASTIC SMALL OUTLINE† (JEDEC MS-012)	PLASTIC DUAL-IN-LINE (JEDEC MS-001)
0°C to 70°C	SN75LBC175AD	SN75LBC175AN
-40°C to 85°C	SN65LBC175AD	SN65LBC175AN

† Add an R suffix for taped and reeled

† For the most current package and ordering information, see the
Package Option Addendum at the end of this document, or see the
TI web site at www.ti.com.

equivalent input and output schematic diagrams

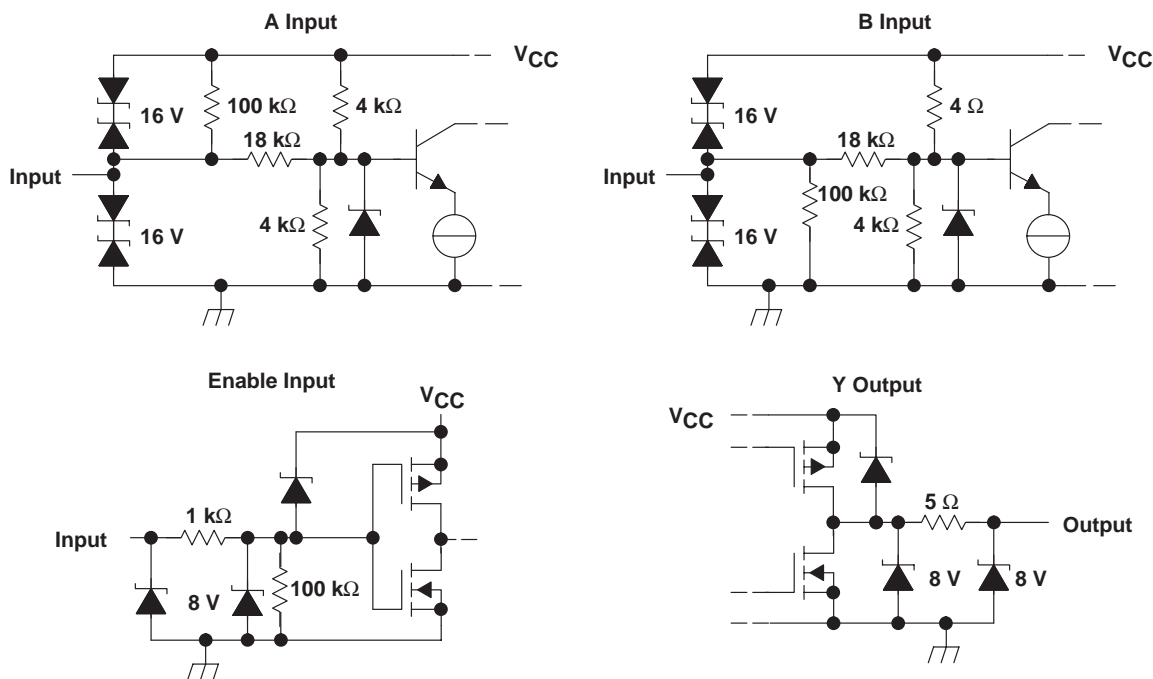

SN65LBC175A, SN75LBC175A QUADRUPLE RS-485 DIFFERENTIAL LINE RECEIVERS

SLLS455B – NOVEMBER 2000 – REVISED MARCH 2005

absolute maximum ratings[†] over operating free-air temperature range (unless otherwise noted)

Supply voltage range, V_{CC} (see Note 1)	–0.3 V to 6 V
Voltage range at any bus input (steady state), A and B	–10 V to 15 V
Voltage range at any bus input (transient pulse through 100 Ω , see Figure 5)	–30 V to 30 V
Voltage input range at 1,2EN and 3,4EN, V_I	–0.5 V to $V_{CC} + 0.5$ V
Receiver output current, I_O	± 10 mA
Electrostatic discharge:	
Human body model (see Note 2): A and B to GND	6 kV
All pins	5 kV
Charged-device model (see Note 3): All pins	2 kV
Continuous power dissipation	See Power Dissipation Rating Table

[†] Stresses beyond those listed under “absolute maximum ratings” may cause permanent damage to the device. These are stress ratings only, and functional operation of the device at these or any other conditions beyond those indicated under “recommended operating conditions” is not implied. Exposure to absolute-maximum-rated conditions for extended periods may affect device reliability.

- NOTES: 1. All voltage values, except differential I/O bus voltages, are with respect to GND, and are steady-state (unless otherwise specified).
 2. Tested in accordance with JEDEC Standard 22, Test Method A114-A.
 3. Tested in accordance with JEDEC Standard 22, Test Method C101.

DISSIPATION RATING TABLE

PACKAGE	$T_A \leq 25^\circ\text{C}$ POWER RATING	DERATING FACTOR [†] ABOVE $T_A = 25^\circ\text{C}$	$T_A = 70^\circ\text{C}$ POWER RATING	$T_A = 85^\circ\text{C}$ POWER RATING
D	1080 mW	8.7 mW/ $^\circ\text{C}$	690 mW	560 mW
N	1150 mW	9.2 mW/ $^\circ\text{C}$	736 mW	598 mW

[†] This is the inverse of the junction-to-ambient thermal resistance when board-mounted and with no air flow.

recommended operating conditions

		MIN	NOM	MAX	UNIT
Supply voltage, V_{CC}		4.75	5	5.25	V
Voltage at any bus terminal	A, B	–7		12	V
High-level input voltage, V_{IH}	EN	2		V_{CC}	V
Low-level input voltage, V_{IL}		0		0.8	
Output current	Y	–8		8	mA
Operating free-air temperature, T_A	SN75LBC175A	0		70	$^\circ\text{C}$
	SN65LBC175A	–40		85	

SN65LBC175A, SN75LBC175A QUADRUPLE RS-485 DIFFERENTIAL LINE RECEIVERS

SLLS455B – NOVEMBER 2000 – REVISED MARCH 2005

electrical characteristics over recommended operating conditions

PARAMETER		TEST CONDITIONS	MIN	TYP†	MAX	UNIT
V_{IT+}	Positive-going differential input voltage threshold	$-7\text{ V} \leq V_{CM} \leq 12\text{ V}$ ($V_{CM} = (V_A + V_B) / 2$)	-80	-10		mV
V_{IT-}	Negative-going differential input voltage threshold		-200	-120		
V_{HYS}	Hysteresis voltage ($V_{IT+} - V_{IT-}$)		-40			mV
V_{IK}	Input clamp voltage	$I_I = -18\text{ mA}$	-1.5	-0.8		V
V_{OH}	High-level output voltage	$V_{ID} = 200\text{ mV}$, $I_{OH} = -8\text{ mA}$	See Figure 1	2.7	4.8	V
V_{OL}	Low-level output voltage	$V_{ID} = -200\text{ mV}$, $I_{OL} = 8\text{ mA}$		0.2	0.4	
I_{OZ}	High-impedance-state output current	$V_O = 0\text{ V to } V_{CC}$	-1		1	μA
I_I	Line input current	Other input at 0 V, $V_{CC} = 0\text{ V or } 5\text{ V}$		$V_I = 12\text{ V}$ $V_I = -7\text{ V}$	0.9	mA
I_{IH}	High-level input current	Enable inputs			100	
I_{IL}	Low-level input current		-100			μA
R_I	Input resistance	A, B	12			k Ω
I_{CC}	Supply current	$V_{ID} = 5\text{ V}$			20	mA
		No load	1,2EN, 3,4EN at 0 V		11	
						1,2EN, 3,4EN at V_{CC}

† All typical values are at $V_{CC} = 5\text{ V}$ and 25°C .

switching characteristics over recommended operating conditions

PARAMETER		TEST CONDITIONS	MIN	TYP†	MAX	UNIT
t_r	Output rise time	$V_{ID} = -3\text{ V to } 3\text{ V}$, See Figure 2		2	4	ns
t_f	Output fall time			2	4	ns
t_{PLH}	Propagation delay time, low-to-high level output			9	12	16
t_{PHL}	Propagation delay time, high-to-low level output		9	12	16	ns
t_{PZH}	Propagation delay time, high-impedance to high-level output	See Figure 3		27	38	ns
t_{PHZ}	Propagation delay time, high-level to high-impedance output			7	16	ns
t_{PZL}	Propagation delay time, high-impedance to low level output	See Figure 4		29	38	ns
t_{PLZ}	Propagation delay time, low-level to high-impedance output			12	16	ns
$t_{sk(p)}$	Pulse skew ($ t_{PLH} - t_{PHL} $)			0.2	1	ns
$t_{sk(o)}$	Output skew (see Note 4)				2	ns
$t_{sk(pp)}$	Part-to-part skew (see Note 5)				2	ns

† All typical values are at $V_{CC} = 5\text{ V}$ and 25°C .

NOTES: 4. Outputs skew ($t_{sk(o)}$) is the magnitude of the time delay difference between the outputs of a single device with all of the inputs connected together.

5. Part-to-part skew ($t_{sk(pp)}$) is the magnitude of the difference in propagation delay times between any specified terminals of two devices when both devices operate with the same input signals, the same supply voltages, at the same temperature, and have identical packages and test circuits.



PARAMETER MEASUREMENT INFORMATION

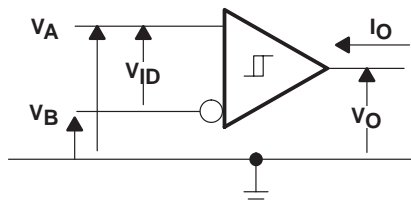

Figure 1. Voltage and Current Definitions

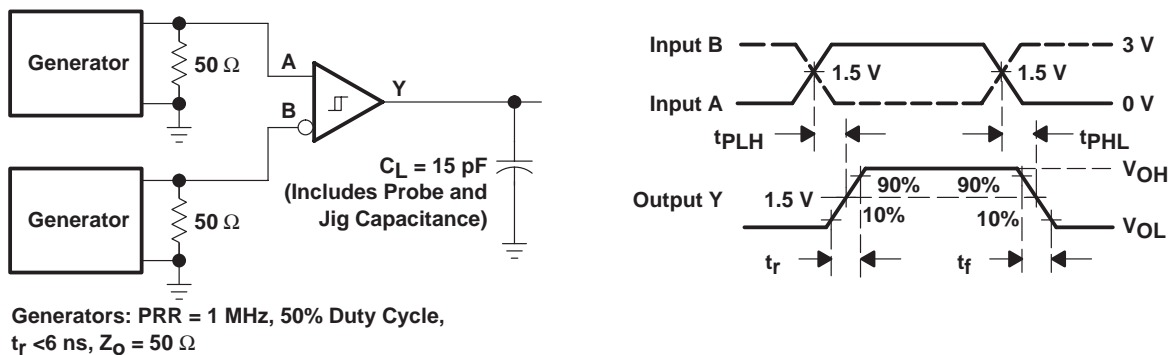

Figure 2. Switching Test Circuit and Waveforms

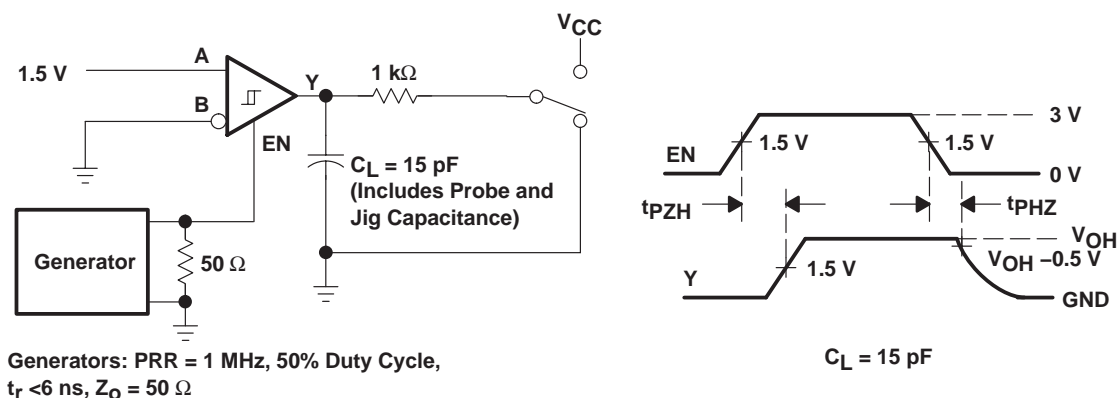

Figure 3. Test Circuit Waveforms, t_{PZH} and t_{PHZ}

SN65LBC175A, SN75LBC175A QUADRUPLE RS-485 DIFFERENTIAL LINE RECEIVERS

SLLS455B – NOVEMBER 2000 – REVISED MARCH 2005

PARAMETER MEASUREMENT INFORMATION

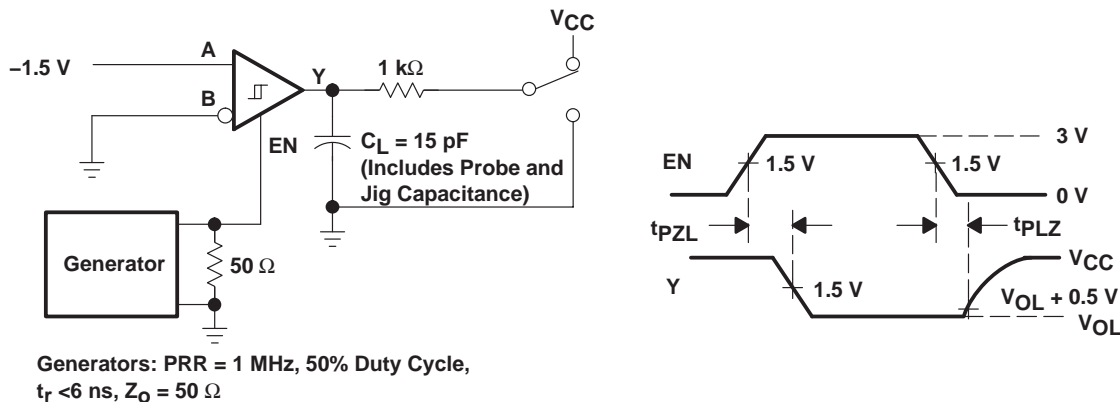

Figure 4. Test Circuit Waveforms, t_{pZL} and t_{pLZ}

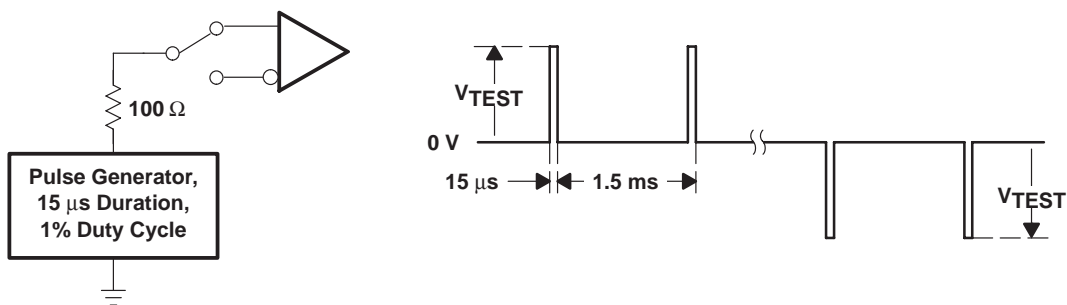

Figure 5. Test Circuit and Waveform, Transient Over-Voltage Test

SN65LBC175A, SN75LBC175A QUADRUPLE RS-485 DIFFERENTIAL LINE RECEIVERS

SLLS455B – NOVEMBER 2000 – REVISED MARCH 2005

TYPICAL CHARACTERISTICS

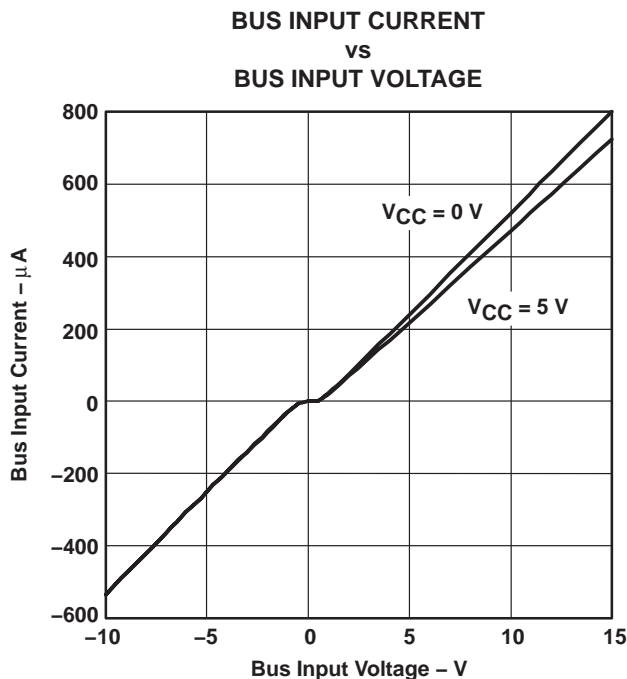

Figure 6

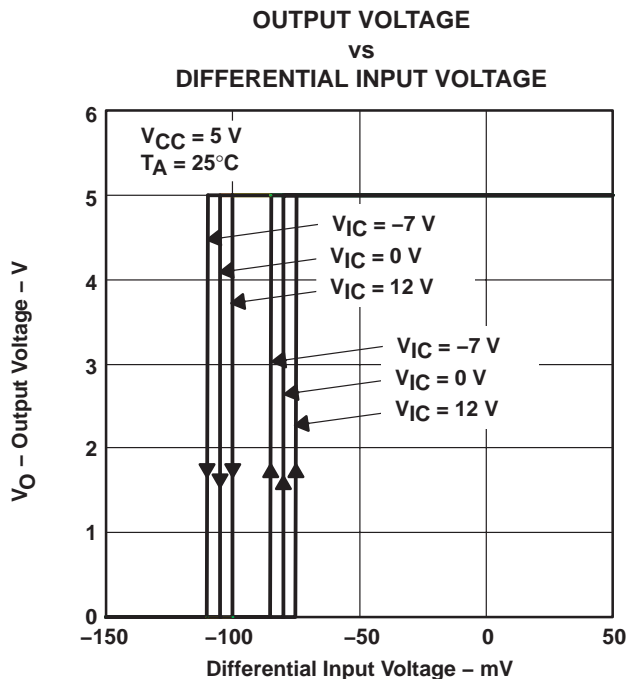

Figure 7

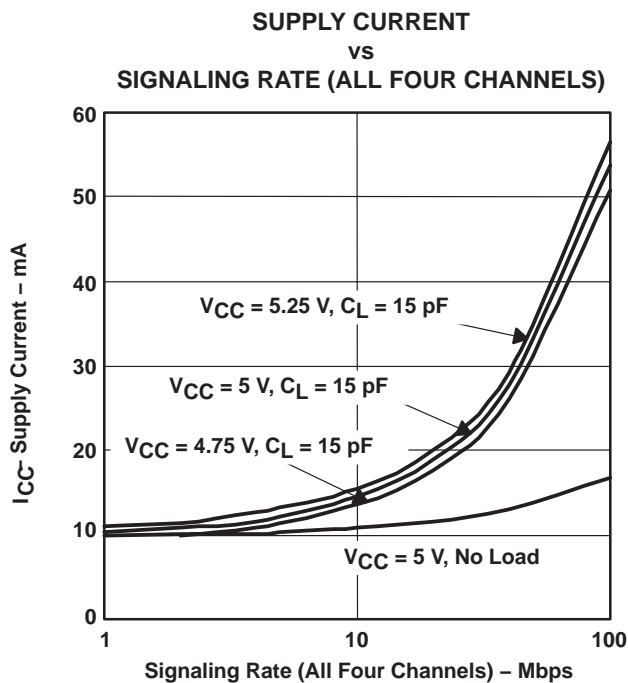

Figure 8

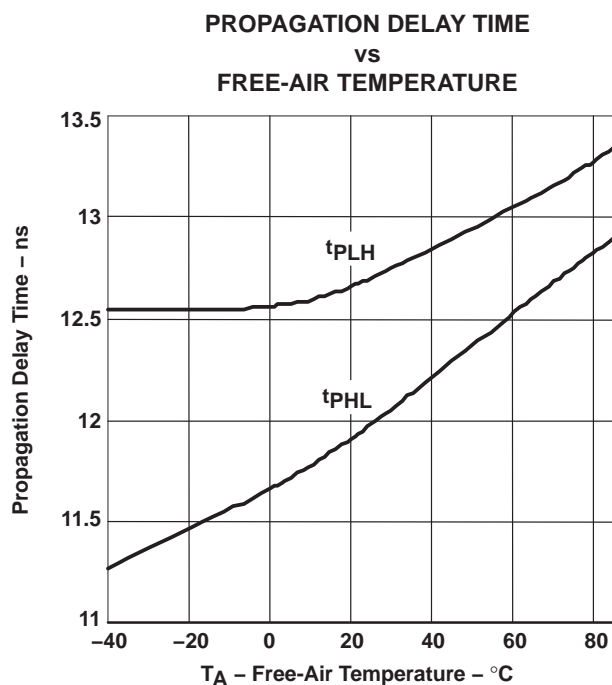

Figure 9

SN65LBC175A, SN75LBC175A QUADRUPLE RS-485 DIFFERENTIAL LINE RECEIVERS

SLLS455B – NOVEMBER 2000 – REVISED MARCH 2005

TYPICAL CHARACTERISTICS

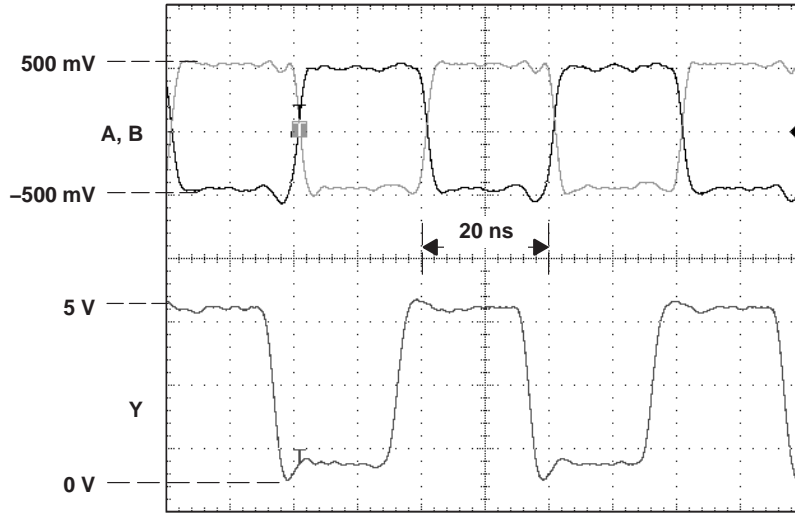

Figure 10. Receiver Inputs and Outputs, 50 Mbps Signaling Rate

SN65LBC175A, SN75LBC175A QUADRUPLE RS-485 DIFFERENTIAL LINE RECEIVERS

SLLS455B – NOVEMBER 2000 – REVISED MARCH 2005

APPLICATION INFORMATION

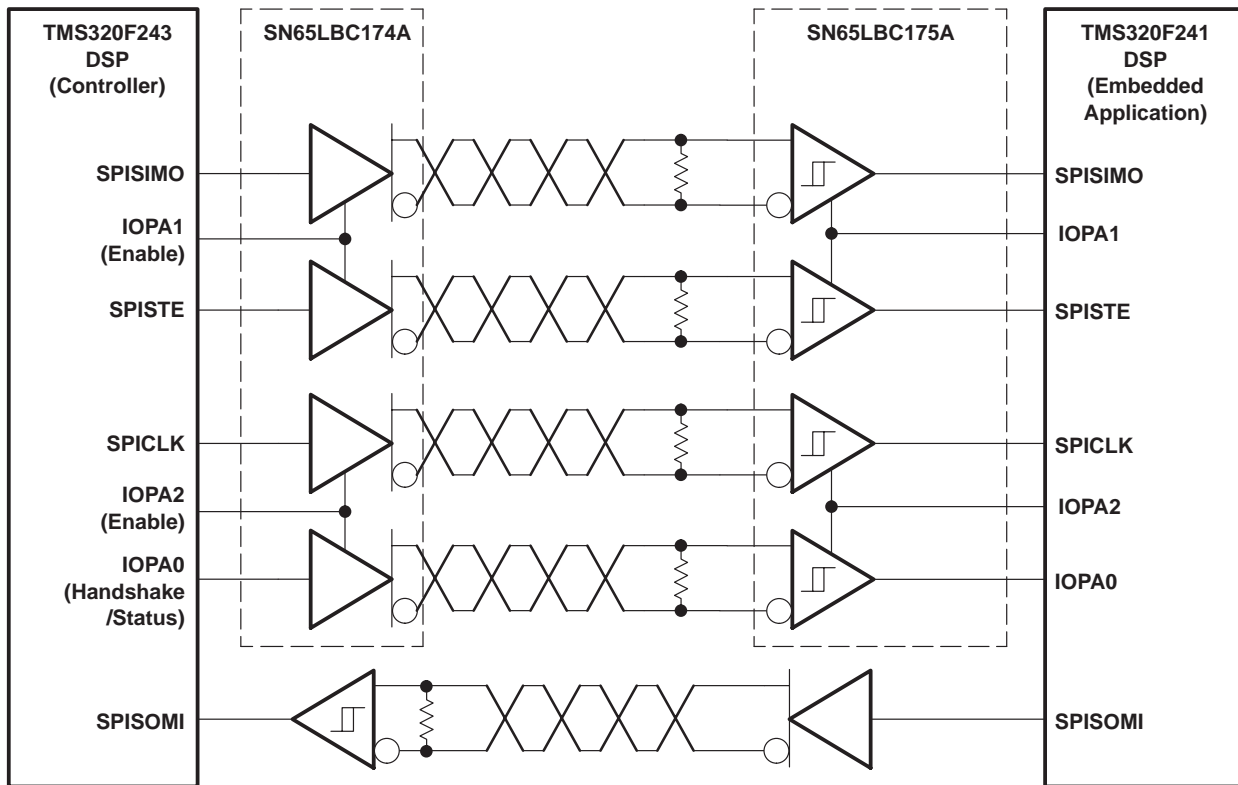

Figure 11. Typical Application Circuit, DSP-to-DSP Link via Serial Peripheral Interface

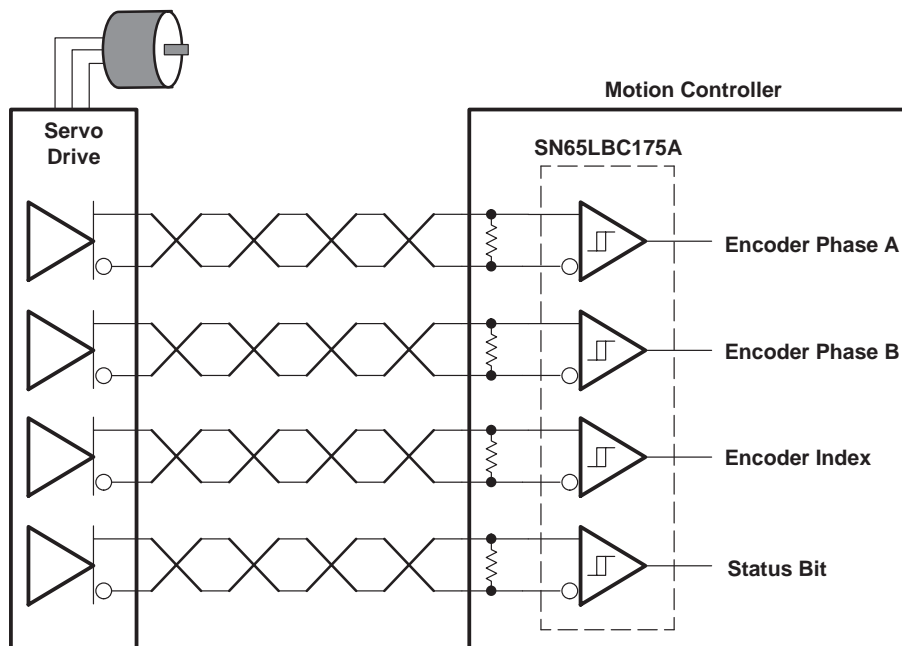

Figure 12. Typical Application Circuit, High-Speed Servomotor Encoder Interface

PACKAGING INFORMATION

Orderable Device	Status ⁽¹⁾	Package Type	Package Drawing	Pins	Package Qty	Eco Plan ⁽²⁾	Lead/Ball Finish	MSL Peak Temp ⁽³⁾
SN65LBC175AD	ACTIVE	SOIC	D	16	40	Green (RoHS & no Sb/Br)	CU NIPDAU	Level-1-260C-UNLIM
SN65LBC175ADG4	ACTIVE	SOIC	D	16	40	Green (RoHS & no Sb/Br)	CU NIPDAU	Level-1-260C-UNLIM
SN65LBC175ADR	ACTIVE	SOIC	D	16	2500	Green (RoHS & no Sb/Br)	CU NIPDAU	Level-1-260C-UNLIM
SN65LBC175ADRG4	ACTIVE	SOIC	D	16	2500	Green (RoHS & no Sb/Br)	CU NIPDAU	Level-1-260C-UNLIM
SN65LBC175AN	ACTIVE	PDIP	N	16	25	Pb-Free (RoHS)	CU NIPDAU	N / A for Pkg Type
SN65LBC175ANE4	ACTIVE	PDIP	N	16	25	Pb-Free (RoHS)	CU NIPDAU	N / A for Pkg Type
SN75LBC175AD	ACTIVE	SOIC	D	16	40	Green (RoHS & no Sb/Br)	CU NIPDAU	Level-1-260C-UNLIM
SN75LBC175ADG4	ACTIVE	SOIC	D	16	40	Green (RoHS & no Sb/Br)	CU NIPDAU	Level-1-260C-UNLIM
SN75LBC175ADR	ACTIVE	SOIC	D	16	2500	Green (RoHS & no Sb/Br)	CU NIPDAU	Level-1-260C-UNLIM
SN75LBC175ADRG4	ACTIVE	SOIC	D	16	2500	Green (RoHS & no Sb/Br)	CU NIPDAU	Level-1-260C-UNLIM
SN75LBC175AN	ACTIVE	PDIP	N	16	25	Pb-Free (RoHS)	CU NIPDAU	N / A for Pkg Type
SN75LBC175ANE4	ACTIVE	PDIP	N	16	25	Pb-Free (RoHS)	CU NIPDAU	N / A for Pkg Type

⁽¹⁾ The marketing status values are defined as follows:

ACTIVE: Product device recommended for new designs.

LIFEBUY: TI has announced that the device will be discontinued, and a lifetime-buy period is in effect.

NRND: Not recommended for new designs. Device is in production to support existing customers, but TI does not recommend using this part in a new design.

PREVIEW: Device has been announced but is not in production. Samples may or may not be available.

OBSOLETE: TI has discontinued the production of the device.

⁽²⁾ Eco Plan - The planned eco-friendly classification: Pb-Free (RoHS), Pb-Free (RoHS Exempt), or Green (RoHS & no Sb/Br) - please check <http://www.ti.com/productcontent> for the latest availability information and additional product content details.

TBD: The Pb-Free/Green conversion plan has not been defined.

Pb-Free (RoHS): TI's terms "Lead-Free" or "Pb-Free" mean semiconductor products that are compatible with the current RoHS requirements for all 6 substances, including the requirement that lead not exceed 0.1% by weight in homogeneous materials. Where designed to be soldered at high temperatures, TI Pb-Free products are suitable for use in specified lead-free processes.

Pb-Free (RoHS Exempt): This component has a RoHS exemption for either 1) lead-based flip-chip solder bumps used between the die and package, or 2) lead-based die adhesive used between the die and leadframe. The component is otherwise considered Pb-Free (RoHS compatible) as defined above.

Green (RoHS & no Sb/Br): TI defines "Green" to mean Pb-Free (RoHS compatible), and free of Bromine (Br) and Antimony (Sb) based flame retardants (Br or Sb do not exceed 0.1% by weight in homogeneous material)

⁽³⁾ MSL, Peak Temp. -- The Moisture Sensitivity Level rating according to the JEDEC industry standard classifications, and peak solder temperature.

Important Information and Disclaimer:The information provided on this page represents TI's knowledge and belief as of the date that it is provided. TI bases its knowledge and belief on information provided by third parties, and makes no representation or warranty as to the accuracy of such information. Efforts are underway to better integrate information from third parties. TI has taken and continues to take reasonable steps to provide representative and accurate information but may not have conducted destructive testing or chemical analysis on incoming materials and chemicals. TI and TI suppliers consider certain information to be proprietary, and thus CAS numbers and other limited information may not be available for release.

In no event shall TI's liability arising out of such information exceed the total purchase price of the TI part(s) at issue in this document sold by TI to Customer on an annual basis.

TAPE AND REEL BOX INFORMATION



A0	Dimension designed to accommodate the component width
B0	Dimension designed to accommodate the component length
K0	Dimension designed to accommodate the component thickness
W	Overall width of the carrier tape
P1	Pitch between successive cavity centers

QUADRANT ASSIGNMENTS FOR PIN 1 ORIENTATION IN TAPE

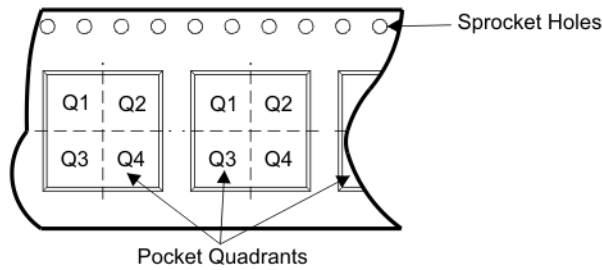

Device	Package	Pins	Site	Reel Diameter (mm)	Reel Width (mm)	A0 (mm)	B0 (mm)	K0 (mm)	P1 (mm)	W (mm)	Pin1 Quadrant
SN65LBC175ADR	D	16	SITE 27	330	0	6.5	10.3	2.1	8	16	Q1
SN75LBC175ADR	D	16	SITE 27	330	0	6.5	10.3	2.1	8	16	Q1

TAPE AND REEL BOX DIMENSIONS



Device	Package	Pins	Site	Length (mm)	Width (mm)	Height (mm)
SN65LBC175ADR	D	16	SITE 27	342.9	336.6	28.58
SN75LBC175ADR	D	16	SITE 27	342.9	336.6	28.58

N (R-PDIP-T**)

PLASTIC DUAL-IN-LINE PACKAGE

16 PINS SHOWN



- NOTES:
- A. All linear dimensions are in inches (millimeters).
 - B. This drawing is subject to change without notice.
 - Falls within JEDEC MS-001, except 18 and 20 pin minimum body length (Dim A).
 - The 20 pin end lead shoulder width is a vendor option, either half or full width.

D (R-PDSO-G16)

PLASTIC SMALL-OUTLINE PACKAGE

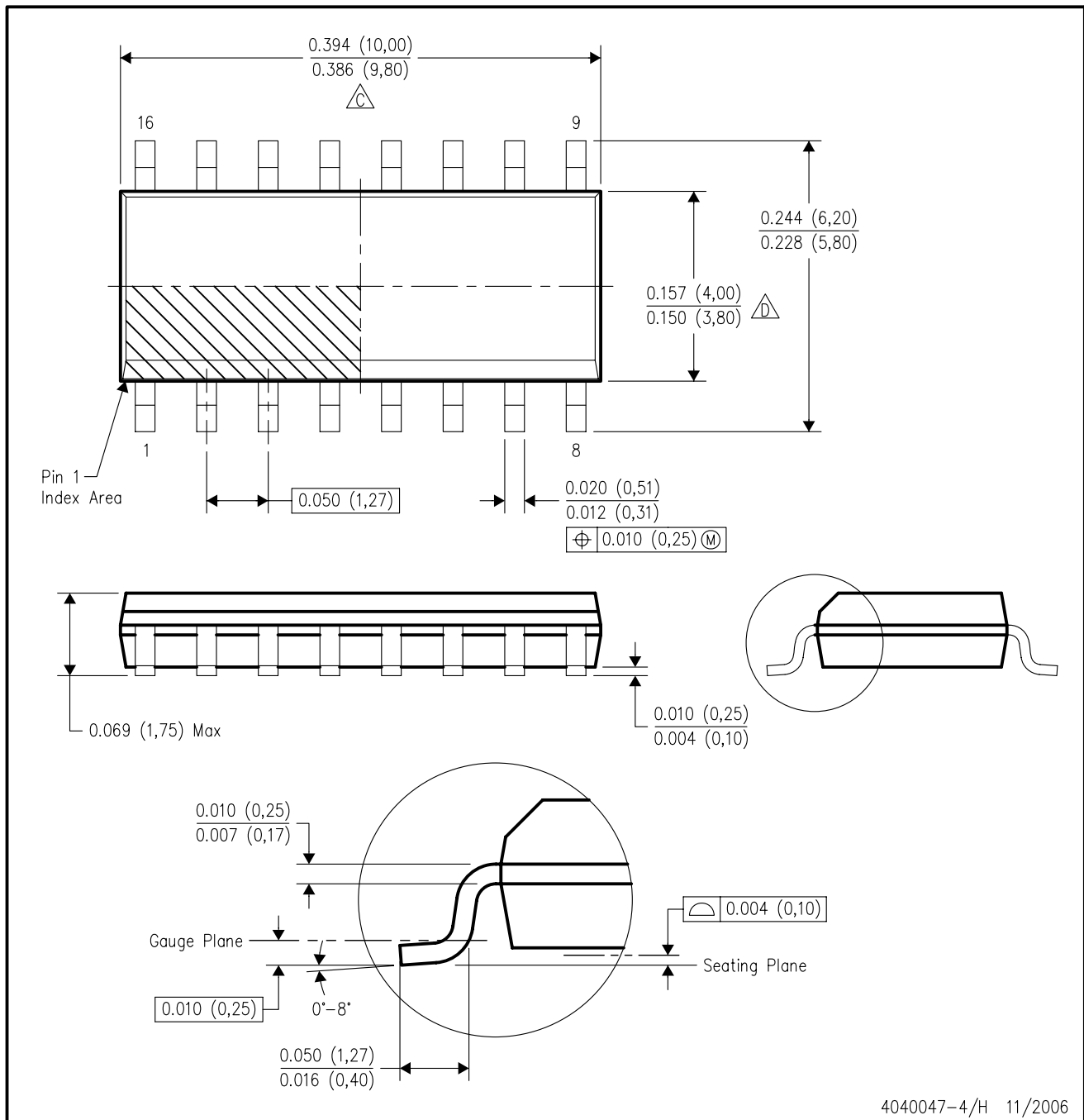

- NOTES:
- A. All linear dimensions are in inches (millimeters).
 - B. This drawing is subject to change without notice.
 - C. Body length does not include mold flash, protrusions, or gate burrs. Mold flash, protrusions, or gate burrs shall not exceed .006 (0,15) per end.
 - D. Body width does not include interlead flash. Interlead flash shall not exceed .017 (0,43) per side.
 - E. Reference JEDEC MS-012 variation AC.

IMPORTANT NOTICE

Texas Instruments Incorporated and its subsidiaries (TI) reserve the right to make corrections, modifications, enhancements, improvements, and other changes to its products and services at any time and to discontinue any product or service without notice. Customers should obtain the latest relevant information before placing orders and should verify that such information is current and complete. All products are sold subject to TI's terms and conditions of sale supplied at the time of order acknowledgment.

TI warrants performance of its hardware products to the specifications applicable at the time of sale in accordance with TI's standard warranty. Testing and other quality control techniques are used to the extent TI deems necessary to support this warranty. Except where mandated by government requirements, testing of all parameters of each product is not necessarily performed.

TI assumes no liability for applications assistance or customer product design. Customers are responsible for their products and applications using TI components. To minimize the risks associated with customer products and applications, customers should provide adequate design and operating safeguards.

TI does not warrant or represent that any license, either express or implied, is granted under any TI patent right, copyright, mask work right, or other TI intellectual property right relating to any combination, machine, or process in which TI products or services are used. Information published by TI regarding third-party products or services does not constitute a license from TI to use such products or services or a warranty or endorsement thereof. Use of such information may require a license from a third party under the patents or other intellectual property of the third party, or a license from TI under the patents or other intellectual property of TI.

Reproduction of TI information in TI data books or data sheets is permissible only if reproduction is without alteration and is accompanied by all associated warranties, conditions, limitations, and notices. Reproduction of this information with alteration is an unfair and deceptive business practice. TI is not responsible or liable for such altered documentation. Information of third parties may be subject to additional restrictions.

Resale of TI products or services with statements different from or beyond the parameters stated by TI for that product or service voids all express and any implied warranties for the associated TI product or service and is an unfair and deceptive business practice. TI is not responsible or liable for any such statements.

TI products are not authorized for use in safety-critical applications (such as life support) where a failure of the TI product would reasonably be expected to cause severe personal injury or death, unless officers of the parties have executed an agreement specifically governing such use. Buyers represent that they have all necessary expertise in the safety and regulatory ramifications of their applications, and acknowledge and agree that they are solely responsible for all legal, regulatory and safety-related requirements concerning their products and any use of TI products in such safety-critical applications, notwithstanding any applications-related information or support that may be provided by TI. Further, Buyers must fully indemnify TI and its representatives against any damages arising out of the use of TI products in such safety-critical applications.

TI products are neither designed nor intended for use in military/aerospace applications or environments unless the TI products are specifically designated by TI as military-grade or "enhanced plastic." Only products designated by TI as military-grade meet military specifications. Buyers acknowledge and agree that any such use of TI products which TI has not designated as military-grade is solely at the Buyer's risk, and that they are solely responsible for compliance with all legal and regulatory requirements in connection with such use.

TI products are neither designed nor intended for use in automotive applications or environments unless the specific TI products are designated by TI as compliant with ISO/TS 16949 requirements. Buyers acknowledge and agree that, if they use any non-designated products in automotive applications, TI will not be responsible for any failure to meet such requirements.

Following are URLs where you can obtain information on other Texas Instruments products and application solutions:

Products		Applications	
Amplifiers	amplifier.ti.com	Audio	www.ti.com/audio
Data Converters	dataconverter.ti.com	Automotive	www.ti.com/automotive
DSP	dsp.ti.com	Broadband	www.ti.com/broadband
Interface	interface.ti.com	Digital Control	www.ti.com/digitalcontrol
Logic	logic.ti.com	Military	www.ti.com/military
Power Mgmt	power.ti.com	Optical Networking	www.ti.com/opticalnetwork
Microcontrollers	microcontroller.ti.com	Security	www.ti.com/security
RFID	www.ti-rfid.com	Telephony	www.ti.com/telephony
Low Power Wireless	www.ti.com/lpw	Video & Imaging	www.ti.com/video
		Wireless	www.ti.com/wireless

Mailing Address: Texas Instruments, Post Office Box 655303, Dallas, Texas 75265
Copyright © 2007, Texas Instruments Incorporated