

SN54LS373, SN54LS374, SN54S373, SN54S374, SN74LS373, SN74LS374, SN74S373, SN74S374

OCTAL D-TYPE TRANSPARENT LATCHES AND EDGE-TRIGGERED FLIP-FLOPS

SDLS165B – OCTOBER 1975 – REVISED AUGUST 2002

- Choice of Eight Latches or Eight D-Type Flip-Flops in a Single Package
- 3-State Bus-Driving Outputs
- Full Parallel Access for Loading
- Buffered Control Inputs
- Clock-Enable Input Has Hysteresis to Improve Noise Rejection ('S373 and 'S374)
- P-N-P Inputs Reduce DC Loading on Data Lines ('S373 and 'S374)

description

These 8-bit registers feature 3-state outputs designed specifically for driving highly capacitive or relatively low-impedance loads. The high-impedance 3-state and increased high-logic-level drive provide these registers with the capability of being connected directly to and driving the bus lines in a bus-organized system without need for interface or pullup components. These devices are particularly attractive for implementing buffer registers, I/O ports, bidirectional bus drivers, and working registers.

The eight latches of the 'LS373 and 'S373 are transparent D-type latches, meaning that while the enable (C or CLK) input is high, the Q outputs follow the data (D) inputs. When C or CLK is taken low, the output is latched at the level of the data that was set up.

The eight flip-flops of the 'LS374 and 'S374 are edge-triggered D-type flip-flops. On the positive transition of the clock, the Q outputs are set to the logic states that were set up at the D inputs.

Schmitt-trigger buffered inputs at the enable/clock lines of the 'S373 and 'S374 devices simplify system design as ac and dc noise rejection is improved by typically 400 mV due to the input hysteresis. A buffered output-control (\overline{OC}) input can be used to place the eight outputs in either a normal logic state (high or low logic levels) or the high-impedance state. In the high-impedance state, the outputs neither load nor drive the bus lines significantly.

\overline{OC} does not affect the internal operation of the latches or flip-flops. That is, the old data can be retained or new data can be entered, even while the outputs are off.

SN54LS373, SN54LS374, SN54S373,
SN54S374 . . . J OR W PACKAGE
SN74LS373, SN74S374 . . . DW, N, OR NS PACKAGE
SN74LS374 . . . DB, DW, N, OR NS PACKAGE
SN74S373 . . . DW OR N PACKAGE
(TOP VIEW)

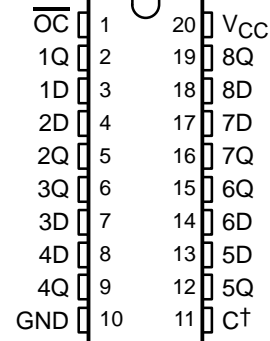

† C for 'LS373 and 'S373; CLK for 'LS374 and 'S374.

SN54LS373, SN54LS374, SN54S373,
SN54S374 . . . FK PACKAGE
(TOP VIEW)



† C for 'LS373 and 'S373; CLK for 'LS374 and 'S374.



Please be aware that an important notice concerning availability, standard warranty, and use in critical applications of Texas Instruments semiconductor products and disclaimers thereto appears at the end of this data sheet.

PRODUCTION DATA information is current as of publication date. Products conform to specifications per the terms of Texas Instruments standard warranty. Production processing does not necessarily include testing of all parameters.

**TEXAS
INSTRUMENTS**

POST OFFICE BOX 655303 • DALLAS, TEXAS 75265

Copyright © 2002, Texas Instruments Incorporated
On products compliant to MIL-PRF-38535, all parameters are tested unless otherwise noted. On all other products, production processing does not necessarily include testing of all parameters.

**SN54LS373, SN54LS374, SN54S373, SN54S374,
SN74LS373, SN74LS374, SN74S373, SN74S374
OCTAL D-TYPE TRANSPARENT LATCHES AND EDGE-TRIGGERED FLIP-FLOPS**

SDLS165B – OCTOBER 1975 – REVISED AUGUST 2002

ORDERING INFORMATION

T_A	PACKAGE†		ORDERABLE PART NUMBER	TOP-SIDE MARKING
0°C to 70°C	PDIP – N	Tube	SN74LS373N	SN74LS373N
		Tube	SN74LS374N	SN74LS374N
		Tube	SN74S373N	SN74S373N
		Tube	SN74S374N	SN74S374N
	SOIC – DW	Tube	SN74LS373DW	LS373
		Tape and reel	SN74LS373DWR	
		Tube	SN74LS374DW	LS374
		Tape and reel	SN74LS374DWR	
		Tube	SN74S373DW	S373
		Tape and reel	SN74S373DWR	
		Tube	SN74S374DW	S374
		Tape and reel	SN74S374DWR	
	SOP – NS	Tape and reel	SN74LS373NSR	74LS373
		Tape and reel	SN74LS374NSR	74LS374
		Tape and reel	SN74S374NSR	74S374
	SSOP – DB	Tape and reel	SN74LS374DBR	LS374A
–55°C to 125°C	CDIP – J	Tube	SN54LS373J	SN54LS373J
		Tube	SNJ54LS373J	SNJ54LS373J
		Tube	SN54LS374J	SN54LS374J
		Tube	SNJ54LS374J	SNJ54LS374J
		Tube	SN54S373J	SN54S373J
		Tube	SNJ54S373J	SNJ54S373J
		Tube	SN54S374J	SN54S374J
		Tube	SNJ54S374J	SNJ54S374J
	CFP – W	Tube	SNJ54LS373W	SNJ54LS373W
		Tube	SNJ54LS374W	SNJ54LS374W
		Tube	SNJ54S374W	SNJ54S374W
	LCCC – FK	Tube	SNJ54LS373FK	SNJ54LS373FK
		Tube	SNJ54LS374FK	SNJ54LS374FK
		Tube	SNJ54S373FK	SNJ54S373FK
		Tube	SNJ54S374FK	SNJ54S374FK

† Package drawings, standard packing quantities, thermal data, symbolization, and PCB design guidelines are available at www.ti.com/sc/package.



**SN54LS373, SN54LS374, SN54S373, SN54S374,
SN74LS373, SN74LS374, SN74S373, SN74S374**
OCTAL D-TYPE TRANSPARENT LATCHES AND EDGE-TRIGGERED FLIP-FLOPS

SDLS165B – OCTOBER 1975 – REVISED AUGUST 2002

Function Tables

'LS373, 'S373
(each latch)

INPUTS			OUTPUT Q
$\overline{\text{OC}}$	C	D	
L	H	H	H
L	H	L	L
L	L	X	Q ₀
H	X	X	Z

'LS374, 'S374
(each latch)

INPUTS			OUTPUT Q
$\overline{\text{OC}}$	CLK	D	
L	↑	H	H
L	↑	L	L
L	L	X	Q ₀
H	X	X	Z

**SN54LS373, SN54LS374, SN54S373, SN54S374,
SN74LS373, SN74LS374, SN74S373, SN74S374**
OCTAL D-TYPE TRANSPARENT LATCHES AND EDGE-TRIGGERED FLIP-FLOPS

SDLS165B – OCTOBER 1975 – REVISED AUGUST 2002

logic diagrams (positive logic)

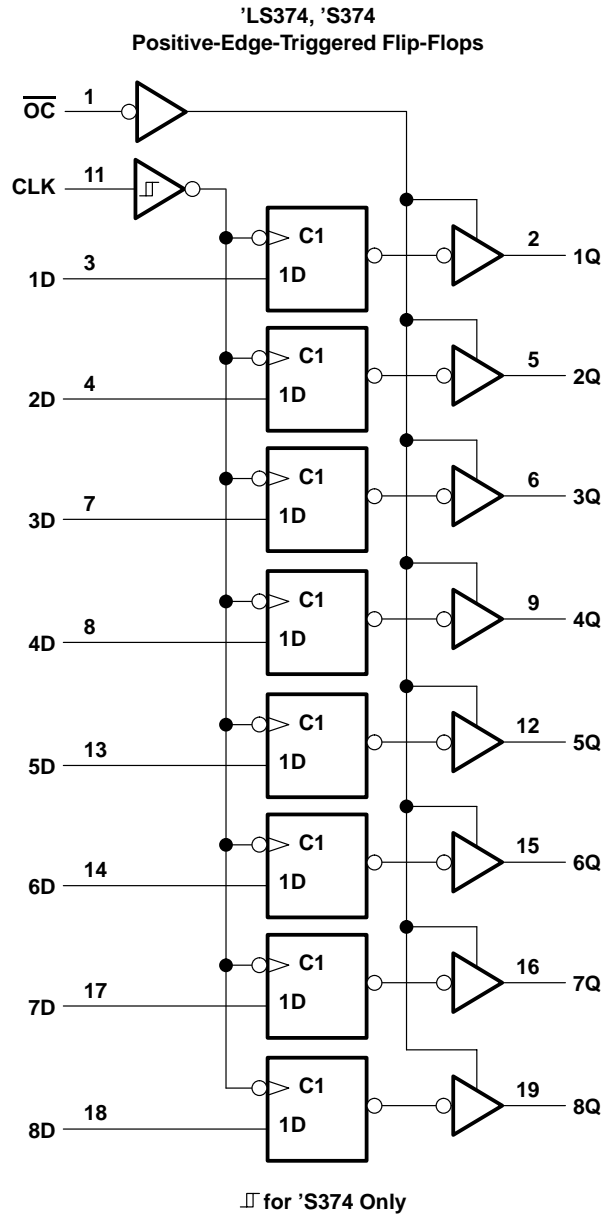

Pin numbers shown are for DB, DW, J, N, NS, and W packages.



POST OFFICE BOX 655303 • DALLAS, TEXAS 75265

**SN54LS373, SN54LS374, SN54S373, SN54S374,
SN74LS373, SN74LS374, SN74S373, SN74S374**

SDLS165B – OCTOBER 1975 – REVISED AUGUST 2002

schematic of inputs and outputs

'LS373



'LS374



**SN54LS373, SN54LS374, SN54S373, SN54S374,
SN74LS373, SN74LS374, SN74S373, SN74S374
OCTAL D-TYPE TRANSPARENT LATCHES AND EDGE-TRIGGERED FLIP-FLOPS**

SDLS165B – OCTOBER 1975 – REVISED AUGUST 2002

**absolute maximum ratings over operating free-air temperature range (unless otherwise noted)†
(‘LS devices)**

Supply voltage, V_{CC} (see Note 1)	7 V
Input voltage, V_I	7 V
Off-state output voltage	5.5 V
Package thermal impedance, θ_{JA} (see Note 2):	
DB package	70°C/W
DW package	58°C/W
N package	69°C/W
NS package	60°C/W
Storage temperature range, T_{stg}	-65°C to 150°C

† Stresses beyond those listed under “absolute maximum ratings” may cause permanent damage to the device. These are stress ratings only, and functional operation of the device at these or any other conditions beyond those indicated under “recommended operating conditions” is not implied. Exposure to absolute-maximum-rated conditions for extended periods may affect device reliability.

- NOTES: 1. Voltage values are with respect to network ground terminal.
2. The package thermal impedance is calculated in accordance with JESD 51-7.

recommended operating conditions

		SN54LS'			SN74LS'			UNIT		
		MIN	NOM	MAX	MIN	NOM	MAX			
V_{CC}	Supply voltage	4.5	5	5	4.75	5	5.25	V		
V_{OH}	High-level output voltage			5.5			5.5	V		
I_{OH}	High-level output current			-1			-2.6	mA		
I_{OL}	Low-level output current			12			24	mA		
t_w	Pulse duration	CLK high		15		15		ns		
		CLK low		15		15				
t_{su}	Data setup time	'LS373		5↓		5↓		ns		
		'LS374		20↑		20↑				
t_h	Data hold time	'LS373		20↓		20↓		ns		
		'LS374‡		5↑		0↑				
T_A	Operating free-air temperature			-55		125		0	70	°C

‡ The t_h specification applies only for data frequency below 10 MHz. Designs above 10 MHz should use a minimum of 5 ns (commercial only).



**SN54LS373, SN54LS374, SN54S373, SN54S374,
SN74LS373, SN74LS374, SN74S373, SN74S374**
OCTAL D-TYPE TRANSPARENT LATCHES AND EDGE-TRIGGERED FLIP-FLOPS

SDLS165B – OCTOBER 1975 – REVISED AUGUST 2002

electrical characteristics over recommended operating free-air temperature range (unless otherwise noted)

PARAMETER	TEST CONDITIONS†	SN54LS'			SN74LS'			UNIT	
		MIN	TYP‡	MAX	MIN	TYP‡	MAX		
V _{IH} High-level input voltage		2			2			V	
V _{IL} Low-level input voltage					0.7			V	
V _{IK} Input clamp voltage	V _{CC} = MIN, I _I = -18 mA				-1.5			V	
V _{OH} High-level output voltage	V _{CC} = MIN, V _{IH} = 2 V, V _{IL} = V _{IL} max, I _{OH} = MAX	2.4	3.4		2.4	3.1		V	
V _{OL} Low-level output voltage	V _{CC} = MIN, V _{IH} = 2 V, V _{IL} = V _{IL} max	I _{OL} = 12 mA			0.25	0.4		V	
		I _{OL} = 24 mA					0.35 0.5		
I _{OZH} Off-state output current, high-level voltage applied	V _{CC} = MAX, V _O = 2.7 V, V _{IH} = 2 V				20			μA	
I _{OZL} Off-state output current, low-level voltage applied	V _{CC} = MAX, V _O = 0.4 V, V _{IH} = 2 V				-20			μA	
I _I Input current at maximum input voltage	V _{CC} = MAX, V _I = 7 V				0.1			mA	
I _{IH} High-level input current	V _{CC} = MAX, V _I = 2.7 V				20			μA	
I _{IL} Low-level input current	V _{CC} = MAX, V _I = 0.4 V				-0.4			mA	
I _{OS} Short-circuit output current§	V _{CC} = MAX				-30	-130	-30	-130	mA
I _{CC} Supply current	V _{CC} = MAX, Output control at 4.5 V	'LS373			24	40	24	40	mA
		'LS374			27	40	27	40	

† For conditions shown as MIN or MAX, use the appropriate value specified under recommended operating conditions.

‡ All typical values are at V_{CC} = 5 V, T_A = 25°C.

§ Not more than one output should be shorted at a time and duration of the short circuit should not exceed one second.

switching characteristics, V_{CC} = 5 V, T_A = 25°C (see Figure 1)

PARAMETER	FROM (INPUT)	TO (OUTPUT)	TEST CONDITIONS	'LS373			'LS374			UNIT
				MIN	TYP	MAX	MIN	TYP	MAX	
f _{max}			R _L = 667 Ω, C _L = 45 pF, See Note 3				35	50		MHz
t _{PLH}	Data	Any Q	R _L = 667 Ω, C _L = 45 pF, See Note 3	12 18						ns
t _{PHL}				12 18						
t _{PLH}	C or CLK	Any Q	R _L = 667 Ω, C _L = 45 pF, See Note 3	20 30			15 28			ns
t _{PHL}				18 30			19 28			
t _{PZH}	\overline{OC}	Any Q	R _L = 667 Ω, C _L = 45 pF, See Note 3	15 28			20 26			ns
t _{PZL}				25 36			21 28			
t _{PHZ}	\overline{OC}	Any Q	R _L = 667 Ω, C _L = 5 pF	15 25			15 28			ns
t _{PLZ}				12 20			12 20			

NOTE 3: Maximum clock frequency is tested with all outputs loaded.

f_{max} = maximum clock frequency

t_{PLH} = propagation delay time, low-to-high-level output

t_{PHL} = propagation delay time, high-to-low-level output

t_{PZH} = output enable time to high level

t_{PZL} = output enable time to low level

t_{PHZ} = output disable time from high level

t_{PLZ} = output disable time from low level



**SN54LS373, SN54LS374, SN54S373, SN54S374,
 SN74LS373, SN74LS374, SN74S373, SN74S374
 OCTAL D-TYPE TRANSPARENT LATCHES AND EDGE-TRIGGERED FLIP-FLOPS**

SDLS165B – OCTOBER 1975 – REVISED AUGUST 2002

schematic of inputs and outputs

'S373 and 'S374

'S373 and 'S374



**SN54LS373, SN54LS374, SN54S373, SN54S374,
SN74LS373, SN74LS374, SN74S373, SN74S374**
OCTAL D-TYPE TRANSPARENT LATCHES AND EDGE-TRIGGERED FLIP-FLOPS

SDLS165B – OCTOBER 1975 – REVISED AUGUST 2002

**absolute maximum ratings over operating free-air temperature range (unless otherwise noted)†
(‘S devices)**

Supply voltage, V_{CC} (see Note 1)	7 V
Input voltage, V_I	5.5 V
Off-state output voltage	5.5 V
Package thermal impedance, θ_{JA} (see Note 2): DW package	58°C/W
N package	69°C/W
NS package	60°C/W
Storage temperature range, T_{stg}	–65°C to 150°C

† Stresses beyond those listed under “absolute maximum ratings” may cause permanent damage to the device. These are stress ratings only, and functional operation of the device at these or any other conditions beyond those indicated under “recommended operating conditions” is not implied. Exposure to absolute-maximum-rated conditions for extended periods may affect device reliability.

- NOTES: 1. Voltage values are with respect to network ground terminal.
2. The package thermal impedance is calculated in accordance with JESD 51-7.

recommended operating conditions

		SN54S'			SN74S'			UNIT
		MIN	NOM	MAX	MIN	NOM	MAX	
V_{CC}	Supply voltage	4.5	5	5.5	4.75	5	5.25	V
V_{OH}	High-level output voltage			5.5			5.5	V
I_{OH}	High-level output current			–2			–6.5	mA
t_w	Pulse duration, clock/enable	High	6		6			ns
		Low	7.3		7.3			
t_{su}	Data setup time	'S373	0↓		0↓			ns
		'S374	5↑		5↑			
t_h	Data hold time	'S373	10↓		10↓			ns
		'S374	2↑		2↑			
T_A	Operating free-air temperature	–55		125	0		70	°C



**SN54LS373, SN54LS374, SN54S373, SN54S374,
SN74LS373, SN74LS374, SN74S373, SN74S374
OCTAL D-TYPE TRANSPARENT LATCHES AND EDGE-TRIGGERED FLIP-FLOPS**

SDLS165B – OCTOBER 1975 – REVISED AUGUST 2002

electrical characteristics over recommended operating free-air temperature range (unless otherwise noted) (SN54S373, SN54S374, SN74S373, SN74S374)

PARAMETER		TEST CONDITIONS†				MIN	TYP‡	MAX	UNIT
V _{IH}						2			V
V _{IL}								0.8	V
V _{IK}		V _{CC} = MIN, I _I = -18 mA						-1.2	V
V _{OH}	SN54S'	V _{CC} = MIN, V _{IH} = 2 V, V _{IL} = 0.8 V, I _{OH} = MAX				2.4	3.4		V
	SN74S'					2.4	3.1		
V _{OL}		V _{CC} = MIN, V _{IH} = 2 V, V _{IL} = 0.8 V, I _{OL} = 20 mA						0.5	V
I _{OZH}		V _{CC} = MAX, V _{IH} = 2 V, V _O = 2.4 V						50	μA
I _{OZL}		V _{CC} = MAX, V _{IH} = 2 V, V _O = 0.5 V						-50	μA
I _I		V _{CC} = MAX, V _I = 5.5 V						1	mA
I _{IH}		V _{CC} = MAX, V _I = 2.7 V						50	μA
I _{IL}		V _{CC} = MAX, V _I = 0.5 V						-250	μA
I _{OS} §		V _{CC} = MAX				-40		-100	mA
I _{CC}	V _{CC} = MAX	'S373	Outputs high				160	mA	
			Outputs low				160		
			Outputs disabled				190		
		'S374	Outputs high				110		
			Outputs low				140		
			Outputs disabled				160		
			CLK and \overline{OC} at 4 V, D inputs at 0 V				180		

† For conditions shown as MIN or MAX, use the appropriate value specified under recommended operating conditions.

‡ All typical values are at V_{CC} = 5 V, T_A = 25°C.

§ Not more than one output should be shorted at a time and duration of the short circuit should not exceed one second.

switching characteristics, V_{CC} = 5 V, T_A = 25°C (see Figure 2)

PARAMETER	FROM (INPUT)	TO (OUTPUT)	TEST CONDITIONS	'S373			'S374			UNIT
				MIN	TYP	MAX	MIN	TYP	MAX	
f _{max}			R _L = 280 Ω, C _L = 15 pF, See Note 3				75	100		MHz
t _{PLH}	Data	Any Q	R _L = 280 Ω, C _L = 15 pF, See Note 3	7	12					ns
t _{PHL}				7	12					
t _{PLH}	C or CLK	Any Q	R _L = 280 Ω, C _L = 15 pF, See Note 3	7	14		8	15		ns
t _{PHL}				12	18		11	17		
t _{PZH}	\overline{OC}	Any Q	R _L = 280 Ω, C _L = 15 pF, See Note 3	8	15		8	15		ns
t _{PZL}				11	18		11	18		
t _{PHZ}	\overline{OC}	Any Q	R _L = 280 Ω, C _L = 5 pF	6	9		5	9		ns
t _{PLZ}				8	12		7	12		

NOTE 3. Maximum clock frequency is tested with all outputs loaded.

f_{max} = maximum clock frequency

t_{PLH} = propagation delay time, low-to-high-level output

t_{PHL} = propagation delay time, high-to-low-level output

t_{PZH} = output enable time to high level

t_{PZL} = output enable time to low level

t_{PHZ} = output disable time from high level

t_{PLZ} = output disable time from low level



**SN54LS373, SN54LS374, SN54S373, SN54S374,
SN74LS373, SN74LS374, SN74S373, SN74S374**

SDLS165B – OCTOBER 1975 – REVISED AUGUST 2002

**PARAMETER MEASUREMENT INFORMATION
SERIES 54LS/74LS DEVICES**



- NOTES: A. C_L includes probe and jig capacitance.
 B. All diodes are 1N3064 or equivalent.
 C. Waveform 1 is for an output with internal conditions such that the output is low except when disabled by the output control. Waveform 2 is for an output with internal conditions such that the output is high except when disabled by the output control.
 D. S1 and S2 are closed for t_{PLH} , t_{PHL} , t_{PHZ} , and t_{PLZ} ; S1 is open and S2 is closed for t_{PZH} ; S1 is closed and S2 is open for t_{PZL} .
 E. Phase relationships between inputs and outputs have been chosen arbitrarily for these examples.
 F. All input pulses are supplied by generators having the following characteristics: $PRR \leq 1$ MHz, $Z_O \approx 50 \Omega$, $t_r \leq 1.5$ ns, $t_f \leq 2.6$ ns.
 G. The outputs are measured one at a time with one input transition per measurement.
 H. All parameters and waveforms are not applicable to all devices.

Figure 1. Load Circuits and Voltage Waveforms

**SN54LS373, SN54LS374, SN54S373, SN54S374,
SN74LS373, SN74LS374, SN74S373, SN74S374
OCTAL D-TYPE TRANSPARENT LATCHES AND EDGE-TRIGGERED FLIP-FLOPS**

SDLS165B – OCTOBER 1975 – REVISED AUGUST 2002

**PARAMETER MEASUREMENT INFORMATION
SERIES 54S/74S DEVICES**



- NOTES: A. C_L includes probe and jig capacitance.
 B. All diodes are 1N3064 or equivalent.
 C. Waveform 1 is for an output with internal conditions such that the output is low except when disabled by the output control. Waveform 2 is for an output with internal conditions such that the output is high except when disabled by the output control.
 D. S1 and S2 are closed for t_{PLH} , t_{PHL} , t_{PHZ} , and t_{PLZ} ; S1 is open and S2 is closed for t_{PZH} ; S1 is closed and S2 is open for t_{PZL} .
 E. All input pulses are supplied by generators having the following characteristics: $PRR \leq 1$ MHz, $Z_O \approx 50 \Omega$; t_r and $t_f \leq 7$ ns for Series 54/74 devices and t_r and $t_f \leq 2.5$ ns for Series 54S/74S devices.
 F. The outputs are measured one at a time with one input transition per measurement.
 G. All parameters and waveforms are not applicable to all devices.

Figure 2. Load Circuits and Voltage Waveforms



**SN54LS373, SN54LS374, SN54S373, SN54S374,
SN74LS373, SN74LS374, SN74S373, SN74S374**

SDLS165B – OCTOBER 1975 – REVISED AUGUST 2002

TYPICAL APPLICATION DATA

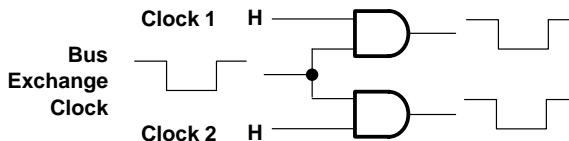

Clock Circuit for Bus Exchange

Expandable 4-Word by 8-Bit General Register File

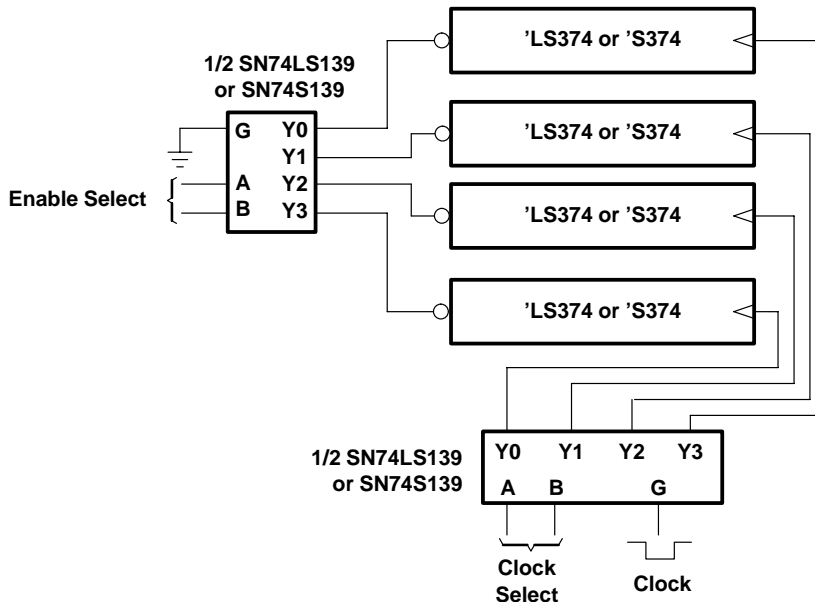

PACKAGING INFORMATION

Orderable Device	Status (1)	Package Type	Package Drawing	Pins	Package Qty	Eco Plan (2)	Lead/Ball Finish (6)	MSL Peak Temp (3)	Op Temp (°C)	Device Marking (4/5)	Samples
78011022A	ACTIVE	LCCC	FK	20	1	TBD	POST-PLATE	N / A for Pkg Type	-55 to 125	78011022A SNJ54LS 374FK	Samples
7801102RA	ACTIVE	CDIP	J	20	1	TBD	A42	N / A for Pkg Type	-55 to 125	7801102RA SNJ54LS374J	Samples
7801102SA	ACTIVE	CFP	W	20	1	TBD	A42	N / A for Pkg Type	-55 to 125	7801102SA SNJ54LS374W	Samples
JM38510/32502B2A	ACTIVE	LCCC	FK	20	1	TBD	POST-PLATE	N / A for Pkg Type	-55 to 125	JM38510/ 32502B2A	Samples
JM38510/32502BRA	ACTIVE	CDIP	J	20	1	TBD	A42	N / A for Pkg Type	-55 to 125	JM38510/ 32502BRA	Samples
JM38510/32502BSA	ACTIVE	CFP	W	20	1	TBD	A42	N / A for Pkg Type	-55 to 125	JM38510/ 32502BSA	Samples
JM38510/32502SRA	ACTIVE	CDIP	J	20	20	TBD	A42	N / A for Pkg Type	-55 to 125	JM38510/ 32502SRA	Samples
JM38510/32502SSA	ACTIVE	CFP	W	20	1	TBD	A42	N / A for Pkg Type	-55 to 125	JM38510/ 32502SSA	Samples
JM38510/32503B2A	ACTIVE	LCCC	FK	20	1	TBD	POST-PLATE	N / A for Pkg Type	-55 to 125	JM38510/ 32503B2A	Samples
JM38510/32503BRA	ACTIVE	CDIP	J	20	1	TBD	A42	N / A for Pkg Type	-55 to 125	JM38510/ 32503BRA	Samples
JM38510/32503BSA	ACTIVE	CFP	W	20	1	TBD	A42	N / A for Pkg Type	-55 to 125	JM38510/ 32503BSA	Samples
M38510/32502B2A	ACTIVE	LCCC	FK	20	1	TBD	POST-PLATE	N / A for Pkg Type	-55 to 125	JM38510/ 32502B2A	Samples
M38510/32502BRA	ACTIVE	CDIP	J	20	1	TBD	A42	N / A for Pkg Type	-55 to 125	JM38510/ 32502BRA	Samples
M38510/32502BSA	ACTIVE	CFP	W	20	1	TBD	A42	N / A for Pkg Type	-55 to 125	JM38510/ 32502BSA	Samples
M38510/32502SRA	ACTIVE	CDIP	J	20	20	TBD	A42	N / A for Pkg Type	-55 to 125	JM38510/ 32502SRA	Samples
M38510/32502SSA	ACTIVE	CFP	W	20	1	TBD	A42	N / A for Pkg Type	-55 to 125	JM38510/ 32502SSA	Samples
M38510/32503B2A	ACTIVE	LCCC	FK	20	1	TBD	POST-PLATE	N / A for Pkg Type	-55 to 125	JM38510/ 32503B2A	Samples

Orderable Device	Status (1)	Package Type	Package Drawing	Pins	Package Qty	Eco Plan (2)	Lead/Ball Finish (6)	MSL Peak Temp (3)	Op Temp (°C)	Device Marking (4/5)	Samples
										32503B2A	
M38510/32503BRA	ACTIVE	CDIP	J	20	1	TBD	A42	N / A for Pkg Type	-55 to 125	JM38510/ 32503BRA	Samples
M38510/32503BSA	ACTIVE	CFP	W	20	1	TBD	A42	N / A for Pkg Type	-55 to 125	JM38510/ 32503BSA	Samples
SN54LS373J	ACTIVE	CDIP	J	20	1	TBD	A42	N / A for Pkg Type	-55 to 125	SN54LS373J	Samples
SN54LS374J	ACTIVE	CDIP	J	20	1	TBD	A42	N / A for Pkg Type	-55 to 125	SN54LS374J	Samples
SN54S373J	ACTIVE	CDIP	J	20	1	TBD	A42	N / A for Pkg Type	-55 to 125	SN54S373J	Samples
SN54S374J	ACTIVE	CDIP	J	20	1	TBD	A42	N / A for Pkg Type	-55 to 125	SN54S374J	Samples
SN74LS373DW	ACTIVE	SOIC	DW	20	25	Green (RoHS & no Sb/Br)	CU NIPDAU	Level-1-260C-UNLIM	0 to 70	LS373	Samples
SN74LS373DWR	ACTIVE	SOIC	DW	20	2000	Green (RoHS & no Sb/Br)	CU NIPDAU	Level-1-260C-UNLIM	0 to 70	LS373	Samples
SN74LS373DWRE4	ACTIVE	SOIC	DW	20	2000	Green (RoHS & no Sb/Br)	CU NIPDAU	Level-1-260C-UNLIM	0 to 70	LS373	Samples
SN74LS373DWRG4	ACTIVE	SOIC	DW	20	2000	Green (RoHS & no Sb/Br)	CU NIPDAU	Level-1-260C-UNLIM	0 to 70	LS373	Samples
SN74LS373N	ACTIVE	PDIP	N	20	20	Pb-Free (RoHS)	CU NIPDAU	N / A for Pkg Type	0 to 70	SN74LS373N	Samples
SN74LS373N3	OBSOLETE	PDIP	N	20		TBD	Call TI	Call TI	0 to 70		
SN74LS373NE4	ACTIVE	PDIP	N	20	20	Pb-Free (RoHS)	CU NIPDAU	N / A for Pkg Type	0 to 70	SN74LS373N	Samples
SN74LS373NSR	ACTIVE	SO	NS	20	2000	Green (RoHS & no Sb/Br)	CU NIPDAU	Level-1-260C-UNLIM	0 to 70	74LS373	Samples
SN74LS374DBR	ACTIVE	SSOP	DB	20	2000	Green (RoHS & no Sb/Br)	CU NIPDAU	Level-1-260C-UNLIM	0 to 70	LS374A	Samples
SN74LS374DW	ACTIVE	SOIC	DW	20	25	Green (RoHS & no Sb/Br)	CU NIPDAU	Level-1-260C-UNLIM	0 to 70	LS374	Samples
SN74LS374DWG4	ACTIVE	SOIC	DW	20	25	Green (RoHS & no Sb/Br)	CU NIPDAU	Level-1-260C-UNLIM	0 to 70	LS374	Samples
SN74LS374DWR	ACTIVE	SOIC	DW	20	2000	Green (RoHS & no Sb/Br)	CU NIPDAU	Level-1-260C-UNLIM	0 to 70	LS374	Samples

Orderable Device	Status (1)	Package Type	Package Drawing	Pins	Package Qty	Eco Plan (2)	Lead/Ball Finish (6)	MSL Peak Temp (3)	Op Temp (°C)	Device Marking (4/5)	Samples
SN74LS374DWRG4	ACTIVE	SOIC	DW	20	2000	Green (RoHS & no Sb/Br)	CU NIPDAU	Level-1-260C-UNLIM	0 to 70	LS374	Samples
SN74LS374J	OBSOLETE	CDIP	J	20		TBD	Call TI	Call TI	0 to 70		
SN74LS374N	ACTIVE	PDIP	N	20	20	Pb-Free (RoHS)	CU NIPDAU	N / A for Pkg Type	0 to 70	SN74LS374N	Samples
SN74LS374N3	OBSOLETE	PDIP	N	20		TBD	Call TI	Call TI	0 to 70		
SN74LS374NE4	ACTIVE	PDIP	N	20	20	Pb-Free (RoHS)	CU NIPDAU	N / A for Pkg Type	0 to 70	SN74LS374N	Samples
SN74LS374NSR	ACTIVE	SO	NS	20	2000	Green (RoHS & no Sb/Br)	CU NIPDAU	Level-1-260C-UNLIM	0 to 70	74LS374	Samples
SN74LS374NSRG4	ACTIVE	SO	NS	20	2000	Green (RoHS & no Sb/Br)	CU NIPDAU	Level-1-260C-UNLIM	0 to 70	74LS374	Samples
SN74S373DW	NRND	SOIC	DW	20	25	Green (RoHS & no Sb/Br)	CU NIPDAU	Level-1-260C-UNLIM	0 to 70	S373	
SN74S373J	OBSOLETE	CDIP	J	20		TBD	Call TI	Call TI	0 to 70		
SN74S373N	NRND	PDIP	N	20	20	Pb-Free (RoHS)	CU NIPDAU	N / A for Pkg Type	0 to 70	SN74S373N	
SN74S373N3	OBSOLETE	PDIP	N	20		TBD	Call TI	Call TI	0 to 70		
SN74S374J	OBSOLETE	CDIP	J	20		TBD	Call TI	Call TI	0 to 70		
SN74S374N	ACTIVE	PDIP	N	20	20	Pb-Free (RoHS)	CU NIPDAU	N / A for Pkg Type	0 to 70	SN74S374N	Samples
SN74S374N3	OBSOLETE	PDIP	N	20		TBD	Call TI	Call TI	0 to 70		
SNJ54LS373FK	ACTIVE	LCCC	FK	20	1	TBD	POST-PLATE	N / A for Pkg Type	-55 to 125	SNJ54LS373FK	Samples
SNJ54LS373J	ACTIVE	CDIP	J	20	1	TBD	A42	N / A for Pkg Type	-55 to 125	SNJ54LS373J	Samples
SNJ54LS373W	ACTIVE	CFP	W	20	1	TBD	A42	N / A for Pkg Type	-55 to 125	SNJ54LS373W	Samples
SNJ54LS374FK	ACTIVE	LCCC	FK	20	1	TBD	POST-PLATE	N / A for Pkg Type	-55 to 125	78011022A SNJ54LS374FK	Samples
SNJ54LS374J	ACTIVE	CDIP	J	20	1	TBD	A42	N / A for Pkg Type	-55 to 125	7801102RA SNJ54LS374J	Samples
SNJ54LS374W	ACTIVE	CFP	W	20	1	TBD	A42	N / A for Pkg Type	-55 to 125	7801102SA SNJ54LS374W	Samples

Orderable Device	Status (1)	Package Type	Package Drawing	Pins	Package Qty	Eco Plan (2)	Lead/Ball Finish (6)	MSL Peak Temp (3)	Op Temp (°C)	Device Marking (4/5)	Samples
SNJ54S373FK	ACTIVE	LCCC	FK	20	1	TBD	POST-PLATE	N / A for Pkg Type	-55 to 125	SNJ54S 373FK	Samples
SNJ54S373J	ACTIVE	CDIP	J	20	1	TBD	A42	N / A for Pkg Type	-55 to 125	SNJ54S373J	Samples
SNJ54S374FK	ACTIVE	LCCC	FK	20	1	TBD	POST-PLATE	N / A for Pkg Type	-55 to 125	SNJ54S 374FK	Samples
SNJ54S374J	ACTIVE	CDIP	J	20	1	TBD	A42	N / A for Pkg Type	-55 to 125	SNJ54S374J	Samples
SNJ54S374W	ACTIVE	CFP	W	20	1	TBD	A42	N / A for Pkg Type	-55 to 125	SNJ54S374W	Samples

(1) The marketing status values are defined as follows:

ACTIVE: Product device recommended for new designs.

LIFEBUY: TI has announced that the device will be discontinued, and a lifetime-buy period is in effect.

NRND: Not recommended for new designs. Device is in production to support existing customers, but TI does not recommend using this part in a new design.

PREVIEW: Device has been announced but is not in production. Samples may or may not be available.

OBSOLETE: TI has discontinued the production of the device.

(2) Eco Plan - The planned eco-friendly classification: Pb-Free (RoHS), Pb-Free (RoHS Exempt), or Green (RoHS & no Sb/Br) - please check <http://www.ti.com/productcontent> for the latest availability information and additional product content details.

TBD: The Pb-Free/Green conversion plan has not been defined.

Pb-Free (RoHS): TI's terms "Lead-Free" or "Pb-Free" mean semiconductor products that are compatible with the current RoHS requirements for all 6 substances, including the requirement that lead not exceed 0.1% by weight in homogeneous materials. Where designed to be soldered at high temperatures, TI Pb-Free products are suitable for use in specified lead-free processes.

Pb-Free (RoHS Exempt): This component has a RoHS exemption for either 1) lead-based flip-chip solder bumps used between the die and package, or 2) lead-based die adhesive used between the die and leadframe. The component is otherwise considered Pb-Free (RoHS compatible) as defined above.

Green (RoHS & no Sb/Br): TI defines "Green" to mean Pb-Free (RoHS compatible), and free of Bromine (Br) and Antimony (Sb) based flame retardants (Br or Sb do not exceed 0.1% by weight in homogeneous material)

(3) MSL, Peak Temp. - The Moisture Sensitivity Level rating according to the JEDEC industry standard classifications, and peak solder temperature.

(4) There may be additional marking, which relates to the logo, the lot trace code information, or the environmental category on the device.

(5) Multiple Device Markings will be inside parentheses. Only one Device Marking contained in parentheses and separated by a "~" will appear on a device. If a line is indented then it is a continuation of the previous line and the two combined represent the entire Device Marking for that device.

(6) Lead/Ball Finish - Orderable Devices may have multiple material finish options. Finish options are separated by a vertical ruled line. Lead/Ball Finish values may wrap to two lines if the finish value exceeds the maximum column width.

Important Information and Disclaimer: The information provided on this page represents TI's knowledge and belief as of the date that it is provided. TI bases its knowledge and belief on information provided by third parties, and makes no representation or warranty as to the accuracy of such information. Efforts are underway to better integrate information from third parties. TI has taken and continues to take reasonable steps to provide representative and accurate information but may not have conducted destructive testing or chemical analysis on incoming materials and chemicals. TI and TI suppliers consider certain information to be proprietary, and thus CAS numbers and other limited information may not be available for release.

In no event shall TI's liability arising out of such information exceed the total purchase price of the TI part(s) at issue in this document sold by TI to Customer on an annual basis.

OTHER QUALIFIED VERSIONS OF SN54LS373, SN54LS373-SP, SN54LS374, SN54LS374-SP, SN54S373, SN54S374, SN74LS373, SN74LS374, SN74S373, SN74S374 :

- Catalog: [SN74LS373](#), [SN54LS373](#), [SN74LS374](#), [SN54LS374](#), [SN74S373](#), [SN74S374](#)
- Military: [SN54LS373](#), [SN54LS374](#), [SN54S373](#), [SN54S374](#)
- Space: [SN54LS373-SP](#), [SN54LS374-SP](#)

NOTE: Qualified Version Definitions:

- Catalog - TI's standard catalog product
- Military - QML certified for Military and Defense Applications
- Space - Radiation tolerant, ceramic packaging and qualified for use in Space-based application

TAPE AND REEL INFORMATION

QUADRANT ASSIGNMENTS FOR PIN 1 ORIENTATION IN TAPE

*All dimensions are nominal

Device	Package Type	Package Drawing	Pins	SPQ	Reel Diameter (mm)	Reel Width W1 (mm)	A0 (mm)	B0 (mm)	K0 (mm)	P1 (mm)	W (mm)	Pin1 Quadrant
SN74LS373DWR	SOIC	DW	20	2000	330.0	24.4	10.8	13.3	2.7	12.0	24.0	Q1
SN74LS373NSR	SO	NS	20	2000	330.0	24.4	9.0	13.0	2.4	4.0	24.0	Q1
SN74LS374DBR	SSOP	DB	20	2000	330.0	16.4	8.2	7.5	2.5	12.0	16.0	Q1
SN74LS374DWR	SOIC	DW	20	2000	330.0	24.4	10.8	13.3	2.7	12.0	24.0	Q1
SN74LS374NSR	SO	NS	20	2000	330.0	24.4	9.0	13.0	2.5	4.0	24.0	Q1

TAPE AND REEL BOX DIMENSIONS

*All dimensions are nominal

Device	Package Type	Package Drawing	Pins	SPQ	Length (mm)	Width (mm)	Height (mm)
SN74LS373DWR	SOIC	DW	20	2000	367.0	367.0	45.0
SN74LS373NSR	SO	NS	20	2000	367.0	367.0	45.0
SN74LS374DBR	SSOP	DB	20	2000	367.0	367.0	38.0
SN74LS374DWR	SOIC	DW	20	2000	367.0	367.0	45.0
SN74LS374NSR	SO	NS	20	2000	367.0	367.0	45.0

J (R-GDIP-T**)

14 LEADS SHOWN

CERAMIC DUAL IN-LINE PACKAGE



DIM \ PINS **	14	16	18	20
A	0.300 (7,62) BSC	0.300 (7,62) BSC	0.300 (7,62) BSC	0.300 (7,62) BSC
B MAX	0.785 (19,94)	.840 (21,34)	0.960 (24,38)	1.060 (26,92)
B MIN	—	—	—	—
C MAX	0.300 (7,62)	0.300 (7,62)	0.310 (7,87)	0.300 (7,62)
C MIN	0.245 (6,22)	0.245 (6,22)	0.220 (5,59)	0.245 (6,22)



4040083/F 03/03

- NOTES:
- All linear dimensions are in inches (millimeters).
 - This drawing is subject to change without notice.
 - This package is hermetically sealed with a ceramic lid using glass frit.
 - Index point is provided on cap for terminal identification only on press ceramic glass frit seal only.
 - Falls within MIL STD 1835 GDIP1-T14, GDIP1-T16, GDIP1-T18 and GDIP1-T20.

W (R-GDFP-F20)

CERAMIC DUAL FLATPACK



- NOTES:
- A. All linear dimensions are in inches (millimeters).
 - B. This drawing is subject to change without notice.
 - C. This package can be hermetically sealed with a ceramic lid using glass frit.
 - D. Index point is provided on cap for terminal identification only.
 - E. Falls within Mil-Std 1835 GDFP2-F20

FK (S-CQCC-N**)

LEADLESS CERAMIC CHIP CARRIER

28 TERMINAL SHOWN



NO. OF TERMINALS **	A		B	
	MIN	MAX	MIN	MAX
20	0.342 (8,69)	0.358 (9,09)	0.307 (7,80)	0.358 (9,09)
28	0.442 (11,23)	0.458 (11,63)	0.406 (10,31)	0.458 (11,63)
44	0.640 (16,26)	0.660 (16,76)	0.495 (12,58)	0.560 (14,22)
52	0.740 (18,78)	0.761 (19,32)	0.495 (12,58)	0.560 (14,22)
68	0.938 (23,83)	0.962 (24,43)	0.850 (21,6)	0.858 (21,8)
84	1.141 (28,99)	1.165 (29,59)	1.047 (26,6)	1.063 (27,0)



4040140/D 01/11

- NOTES:
- All linear dimensions are in inches (millimeters).
 - This drawing is subject to change without notice.
 - This package can be hermetically sealed with a metal lid.
 - Falls within JEDEC MS-004

N (R-PDIP-T**)

PLASTIC DUAL-IN-LINE PACKAGE

16 PINS SHOWN



- NOTES:
- A. All linear dimensions are in inches (millimeters).
 - B. This drawing is subject to change without notice.
 - Falls within JEDEC MS-001, except 18 and 20 pin minimum body length (Dim A).
 - The 20 pin end lead shoulder width is a vendor option, either half or full width.

4040049/E 12/2002

DW0020A



PACKAGE OUTLINE

SOIC - 2.65 mm max height

SOIC



4220724/A 05/2016

NOTES:

1. All linear dimensions are in millimeters. Dimensions in parenthesis are for reference only. Dimensioning and tolerancing per ASME Y14.5M.
2. This drawing is subject to change without notice.
3. This dimension does not include mold flash, protrusions, or gate burrs. Mold flash, protrusions, or gate burrs shall not exceed 0.15 mm per side.
4. This dimension does not include interlead flash. Interlead flash shall not exceed 0.43 mm per side.
5. Reference JEDEC registration MS-013.

EXAMPLE BOARD LAYOUT

DW0020A

SOIC - 2.65 mm max height

SOIC



LAND PATTERN EXAMPLE
SCALE:6X



SOLDER MASK DETAILS

4220724/A 05/2016

NOTES: (continued)

- 6. Publication IPC-7351 may have alternate designs.
- 7. Solder mask tolerances between and around signal pads can vary based on board fabrication site.

EXAMPLE STENCIL DESIGN

DW0020A

SOIC - 2.65 mm max height

SOIC



SOLDER PASTE EXAMPLE
BASED ON 0.125 mm THICK STENCIL
SCALE:6X

4220724/A 05/2016

NOTES: (continued)

8. Laser cutting apertures with trapezoidal walls and rounded corners may offer better paste release. IPC-7525 may have alternate design recommendations.
9. Board assembly site may have different recommendations for stencil design.

DB (R-PDSO-G**)

PLASTIC SMALL-OUTLINE

28 PINS SHOWN



- NOTES: A. All linear dimensions are in millimeters.
 B. This drawing is subject to change without notice.
 C. Body dimensions do not include mold flash or protrusion not to exceed 0,15.
 D. Falls within JEDEC MO-150

MECHANICAL DATA

NS (R-PDSO-G**)

PLASTIC SMALL-OUTLINE PACKAGE

14-PINS SHOWN



- NOTES:
- A. All linear dimensions are in millimeters.
 - B. This drawing is subject to change without notice.
 - C. Body dimensions do not include mold flash or protrusion, not to exceed 0,15.

IMPORTANT NOTICE

Texas Instruments Incorporated and its subsidiaries (TI) reserve the right to make corrections, enhancements, improvements and other changes to its semiconductor products and services per JESD46, latest issue, and to discontinue any product or service per JESD48, latest issue. Buyers should obtain the latest relevant information before placing orders and should verify that such information is current and complete. All semiconductor products (also referred to herein as "components") are sold subject to TI's terms and conditions of sale supplied at the time of order acknowledgment.

TI warrants performance of its components to the specifications applicable at the time of sale, in accordance with the warranty in TI's terms and conditions of sale of semiconductor products. Testing and other quality control techniques are used to the extent TI deems necessary to support this warranty. Except where mandated by applicable law, testing of all parameters of each component is not necessarily performed.

TI assumes no liability for applications assistance or the design of Buyers' products. Buyers are responsible for their products and applications using TI components. To minimize the risks associated with Buyers' products and applications, Buyers should provide adequate design and operating safeguards.

TI does not warrant or represent that any license, either express or implied, is granted under any patent right, copyright, mask work right, or other intellectual property right relating to any combination, machine, or process in which TI components or services are used. Information published by TI regarding third-party products or services does not constitute a license to use such products or services or a warranty or endorsement thereof. Use of such information may require a license from a third party under the patents or other intellectual property of the third party, or a license from TI under the patents or other intellectual property of TI.

Reproduction of significant portions of TI information in TI data books or data sheets is permissible only if reproduction is without alteration and is accompanied by all associated warranties, conditions, limitations, and notices. TI is not responsible or liable for such altered documentation. Information of third parties may be subject to additional restrictions.

Resale of TI components or services with statements different from or beyond the parameters stated by TI for that component or service voids all express and any implied warranties for the associated TI component or service and is an unfair and deceptive business practice. TI is not responsible or liable for any such statements.

Buyer acknowledges and agrees that it is solely responsible for compliance with all legal, regulatory and safety-related requirements concerning its products, and any use of TI components in its applications, notwithstanding any applications-related information or support that may be provided by TI. Buyer represents and agrees that it has all the necessary expertise to create and implement safeguards which anticipate dangerous consequences of failures, monitor failures and their consequences, lessen the likelihood of failures that might cause harm and take appropriate remedial actions. Buyer will fully indemnify TI and its representatives against any damages arising out of the use of any TI components in safety-critical applications.

In some cases, TI components may be promoted specifically to facilitate safety-related applications. With such components, TI's goal is to help enable customers to design and create their own end-product solutions that meet applicable functional safety standards and requirements. Nonetheless, such components are subject to these terms.

No TI components are authorized for use in FDA Class III (or similar life-critical medical equipment) unless authorized officers of the parties have executed a special agreement specifically governing such use.

Only those TI components which TI has specifically designated as military grade or "enhanced plastic" are designed and intended for use in military/aerospace applications or environments. Buyer acknowledges and agrees that any military or aerospace use of TI components which have **not** been so designated is solely at the Buyer's risk, and that Buyer is solely responsible for compliance with all legal and regulatory requirements in connection with such use.

TI has specifically designated certain components as meeting ISO/TS16949 requirements, mainly for automotive use. In any case of use of non-designated products, TI will not be responsible for any failure to meet ISO/TS16949.

Products

Audio	www.ti.com/audio
Amplifiers	amplifier.ti.com
Data Converters	dataconverter.ti.com
DLP® Products	www.dlp.com
DSP	dsp.ti.com
Clocks and Timers	www.ti.com/clocks
Interface	interface.ti.com
Logic	logic.ti.com
Power Mgmt	power.ti.com
Microcontrollers	microcontroller.ti.com
RFID	www.ti-rfid.com
OMAP Applications Processors	www.ti.com/omap
Wireless Connectivity	www.ti.com/wirelessconnectivity

Applications

Automotive and Transportation	www.ti.com/automotive
Communications and Telecom	www.ti.com/communications
Computers and Peripherals	www.ti.com/computers
Consumer Electronics	www.ti.com/consumer-apps
Energy and Lighting	www.ti.com/energy
Industrial	www.ti.com/industrial
Medical	www.ti.com/medical
Security	www.ti.com/security
Space, Avionics and Defense	www.ti.com/space-avionics-defense
Video and Imaging	www.ti.com/video

TI E2E Community

e2e.ti.com