

Z-WAVE® MODEM SOC

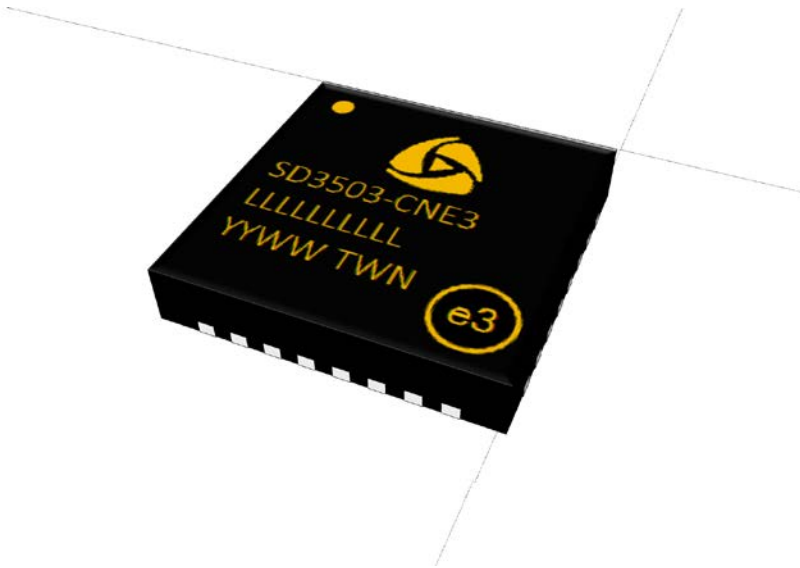

The SD3503 modem SoC is designed for easy integration and time to market. It is an ideal solution for Controllers in applications such as TVs, Set Top Boxes, Gateways, and USB sticks. Z-Wave has a ten year track record of backwards compatibility. SD3503 continues to build on this legacy that enables all generations of Z-Wave to communicate seamlessly in a Z-Wave Network.

The SD3503 Modem SoC is a Z-Wave Modem solution. Silicon Labs is providing the SD3503 firmware as binaries. The firmware exposes the well documented and proven Z-Wave Serial-API both on USB and UART.

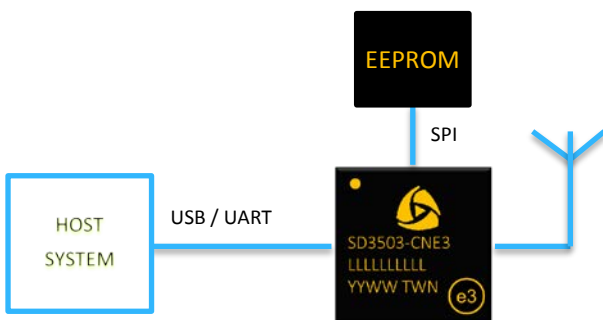

Figure 1: Application example

Firmware upgrades can be performed through UART or USB as new features become available in the future. Existing users of the Z-Wave Serial-API can easily upgrade to the SD3503 Modem SoC while reusing the host application.

Target Applications

- Gateways
- TVs
- Set-Top Boxes
- USB sticks
- ITU-T G.9959 compliant devices (Short range narrowband digital radio-communication transceivers)

Features

- QFN32 5x5 mm solution to run stack and application
- Low BOM
- 2.3 to 3.6 V operations
- 1 μ A sleep mode
- Maintain Z-Wave network presence within USB power-down mode current budget

Radio Features

- Sensitivity -104dBm
- Transmit power 5dBm
- Z-Wave® 9.6/40/100 kbit/s data rates (actual use depends on region)
- All Z-Wave® sub-1GHz frequency bands and protocols supported, currently spanning from 865.2 to 926 MHz
- Multi-channel and RSSI listen before talk support (actual use depends on region)

Microcontroller Features

- Cycle optimized 8051 microcontroller
- 128-bit AES security processor and hardware random number generator
- FLASH, XRAM, 256 byte IRAM, 128 byte data-retention RAM, 256 byte data NVM
- Flash loader in ROM
- Cold start power up time in less than 1 ms
- Programmable via USB, UART, Over-The-Air
- Battery monitor

The SD3503 provides hardware-assisted frequency agility, enabling the module to switch away from a noisy channel without any communication overhead.

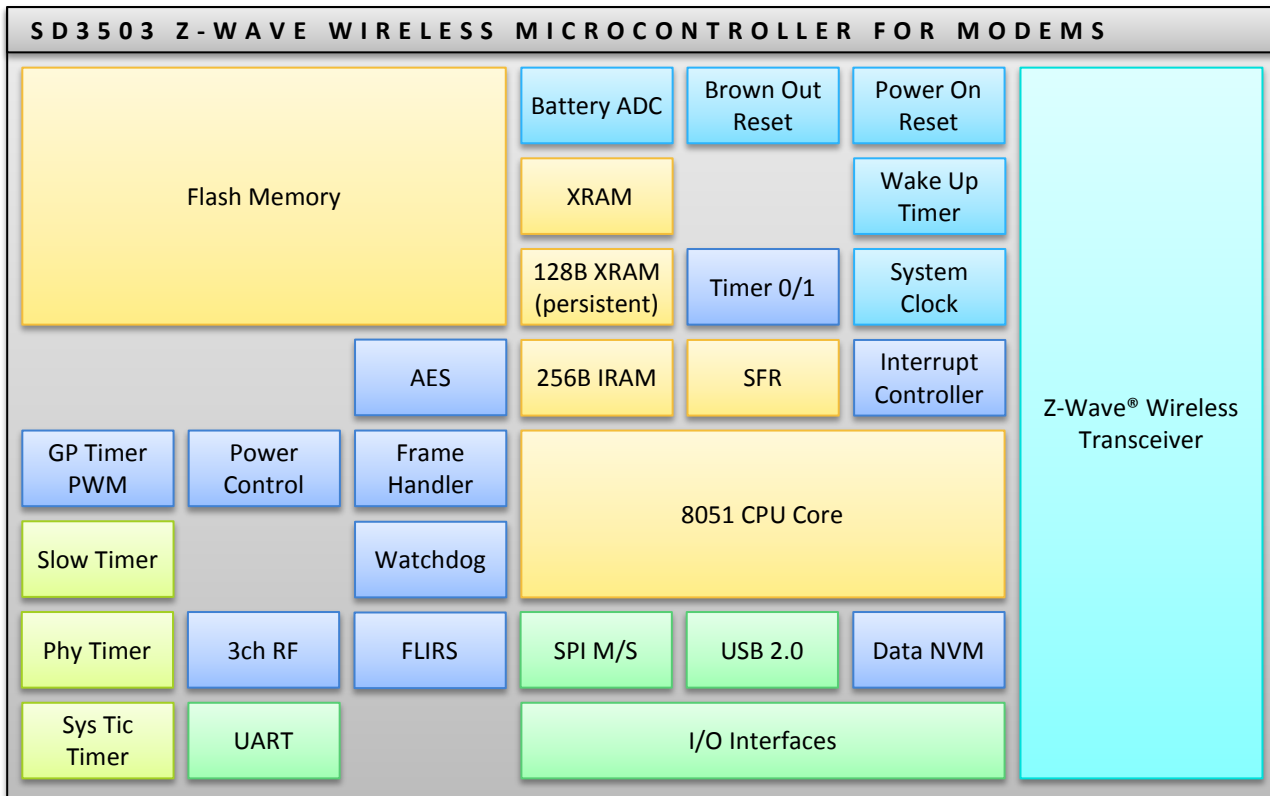

Figure 2: Architecture

DESCRIPTION

The SD3503 Z-Wave® single chip, wireless microcontroller comprises an integrated multi-band, multi-channel, multi-speed RF transceiver, 8051 microcontroller, SPI, UART, SRAM, 128k-byte FLASH, and data-NVM memory for sharing between a user application and the Z-Wave protocol.

Due to its patented multi-channel support and excellent interference blocking performance, the SD3503 provides superior robustness. The Z-Wave system uses frequency agility, frame acknowledgement, retransmission, collision avoidance, frame checksum check, and sophisticated mesh routing for reliable full home coverage. Products based on the SD3503 are fully interoperable with existing Z-Wave solutions.

CONTENT

DESCRIPTION 2

CONTENT 2

ELECTRICAL SPECIFICATIONS 5

 POWER CONSUMPTION 5

 SYSTEM TIMING 5

NON-VOLATILE MEMORIES.....	6
RF TRANSCEIVER CHARACTERISTICS.....	6
DIGITAL IO CHARACTERISTICS.....	7
3.3V systems.....	7
Sub 3V systems.....	8
Typical IO characteristics, $V_{DD}= 2.3V$ to $3.6V$, $T_A = -40$ to $+90^{\circ}C$	8
BATTERY-ADC CHARACTERISTICS.....	9
ABSOLUTE MAXIMUM RATINGS.....	10
PRODUCTION TEST CONDITIONS.....	10
QUALIFICATION TEST CONDITIONS.....	10
OVERVIEW.....	11
WIRELESS TRANSCEIVER.....	12
INTERFACING THE FRONT-END.....	12
Z-WAVE FREQUENCY COVERAGE.....	12
CPU.....	13
MODES.....	13
Programming Mode.....	14
PERIPHERALS AND AUXILIARY BLOCKS.....	14
SUPPLY SYSTEM.....	14
XTAL AND SYSTEM CLOCK.....	15
Production considerations.....	15
WAKE-UP-TIMER.....	15
BATTERY MONITOR ADC.....	15
SPI.....	15
UART.....	16
USB.....	17
USB-Bus-Powered And Suspend-Mode Support.....	17
AES SECURITY PROCESSOR.....	17
RESET.....	17
PIN DESCRIPTIONS.....	18
PINS: 900 MHz Z-WAVE RADIO.....	18
PINS: SYSTEM INTERFACE.....	18
PINS PER PIN NUMBER.....	19
PROCESS SPECIFICATION.....	19
PCB MOUNTING AND SOLDERING.....	20
RECOMMENDED PCB MOUNTING PATTERN.....	20
SOLDERING INFORMATION.....	20
ORDERING INFORMATION.....	21
PACKAGE.....	21
REEL.....	22
TOP MARKING.....	24

DOCUMENT CHANGE LIST 25

ELECTRICAL SPECIFICATIONS

NOTES

For absolute Maximum Ratings, refer to page 10.

For Qualification Test Conditions, $T_A = -40$ to 90°C , $V_{DD} = 2.3$ to 3.6V , refer to page 10.

For Production Test Conditions, refer to page 10.

POWER CONSUMPTION

Supply Voltage Range $T_A = -40$ to $+90^\circ\text{C}$		Min	Max	Units
V_{DD}	Supply Voltage	2.3	3.6	V
$V_{DD\text{ USB}}$	Supply Voltage when the USB PHY is used	3.0	3.6	V
V_{BOR}	The supply voltage at which the Brown Out Detector (BOR) resets the chip. The BOR will reset the device if the supply is inadequate to guarantee correct behavior.		2.3	V

Power Saving Modes, $V_{DD} = 3.3\text{V}$, $T_A = 25^\circ\text{C}$		Typ	Max	Units
$I_{VDD\text{ SLEEP}}$	Interruptible sleep mode	1.0	1.6	μA
$\Delta I_{VDD\text{ WUT}}$	Enabling Wake-up Timer in a sleep mode adds	0.7		μA
$\Delta I_{VDD\text{ RAM}}$	Enabling SRAM data persistency in a sleep mode adds	0.1		μA
$I_{\text{USB SLEEP}}$	USB sleep mode with full data & state persistency & Wake-up Timer & system clock	1.9	2.1	mA

Power Saving Modes, $V_{DD} = 3.0$ to 3.6V , $T_A = -40$ to $+90^\circ\text{C}$		Max	Units
$I_{\text{USB SLEEP}}$	USB suspend mode with full data & state persistency & Wake-up Timer & system clock	2.3	mA

Active Modes, $V_{DD} = 3.3\text{V}$, $T_A = 25^\circ\text{C}$		Typ	Max	Units
$I_{VDD\text{ MCU}}$	MCU running at 32MHz	15	16	mA
$I_{VDD\text{ MCU RX}}$	MCU and receiver (RX mode)	32	34	mA
$I_{VDD\text{ MCU TX } 0.5}$	MCU and transmitter (TX mode), 0.5 dBm	34	36	mA
$I_{VDD\text{ MCU TX } 3.5}$	MCU and transmitter (TX mode), 3.5 dBm	36	38	mA
$\Delta I_{VDD\text{ ADC}}$	Using the ADC adds	0.15	0.25	mA
$\Delta I_{VDD\text{ USB}}$	Using the USB adds			mA

Programming modes, $V_{DD} = 3.3\text{V}$, $T_A = 25^\circ\text{C}$		Typ	Max	Units
$I_{VDD\text{ PGM USB}}$	Programming via USB	15		mA
$I_{VDD\text{ PGM UART}}$	Programming via UART	15	16	mA

SYSTEM TIMING

System Start-Up Time, $V_{DD} = 2.3$ to 3.6V , $T_A = -40$ to $+90^\circ\text{C}$		Max	Units
$T_{\text{POWER UP}}$	System Start-Up Time, measured from the supply voltage reach the minimum $V_{DD} (=2.3\text{V})$ and to the MCU responds, using qualification schematic and a power rise time not exceeding $10\mu\text{s}$. Note 1: This value applies identically for recovery after brown-out events. Note 2: There is no restriction on the supply rise time. But an increase in power rise time will increase the Start-Up time proportionally.	1	ms

Wake-up Timer precision, $V_{DD} = 2.3$ to $3.6V$, $T_A = -40$ to $+90^{\circ}C$		Max	Units
TWUT_OFFSET	Wake-up Timer accuracy, max offset deviation	40	ms
TWUT_SCALE	Wake-up Timer accuracy, max scale deviation	2%	

Reset and Interrupt timing requirements, $V_{DD} = 2.3$ to $3.6V$, $T_A = -40$ to $+90^{\circ}C$		Max	Units
T_RST_PULSE	Minimum time RESET_N must be held down to guarantee a full system reset	20	ns
T_INT_PULSE	To guarantee recognition of an external interrupt pulse, an input pin, if configured to sample external interrupts, must be held down two complete clock cycles.	65	ns

NON-VOLATILE MEMORIES

Endurance and Retention		Min	Units
	FLASH (code) endurance	10k	cycle
	Data NVM endurance	100k	cycle
	FLASH Retention	100	year
	Data NVM Retention	100	year

The Flash and the NVM Data Array is built with SuperFlash® technology.

RF TRANSCEIVER CHARACTERISTICS

Transmit Power, $V_{DD} = 2.3$ to $3.6V$, $T_A = -40$ to $+90^{\circ}C$		Min	Max	Units
P _{0x3F}	RF output power delivered to 50 Ω at max software setting	4.3	6.5	dBm
P _{0x01}	Same as above, but at min software setting	-24.5	-22	dBm
P _{h2,0dBm}	2 nd harmonics content, PA setting 20 ~ 0dBm		-50	dBc
P _{h2,5dBm}	2 nd harmonics content, PA setting 63 ~ 5dBm		-30	dBc
P _{h3,0dBm}	3 rd harmonics content, PA setting 20 ~ 0dBm		-30	dBc
P _{h3,5dBm}	3 rd harmonics content, PA setting 63 ~ 5dBm		-20	dBc

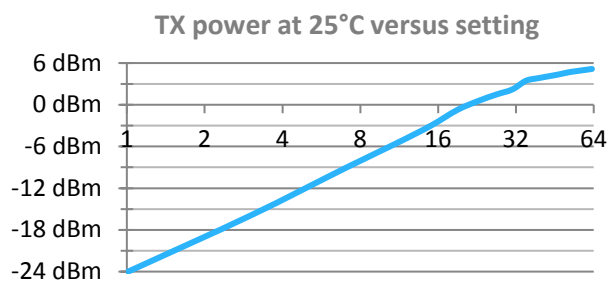

Figure 3: Typical Transmit Power versus Digital Setting

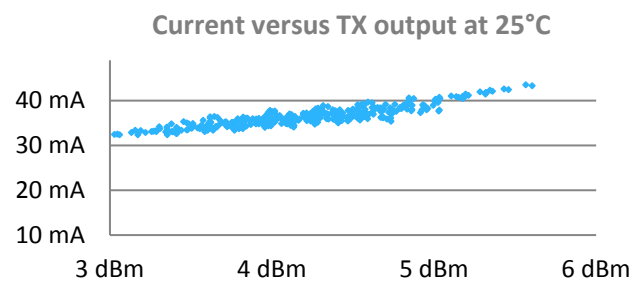

Figure 4: Typical current consumption versus TX power

Receiver Sensitivity, $V_{DD} = 2.3$ to $3.6V$, $T_A = -40$ to $+90^{\circ}C$		Max	Units
P _{9.6}	Sensitivity at 9.6 kbit/s. Defined as the lowest power at which the frame error rate is less than 3%	-104	dBm
P ₄₀	Sensitivity at 40 kbit/s, defined as above	-99	dBm
P ₁₀₀	Sensitivity at 100 kbit/s, defined as above	-92	dBm

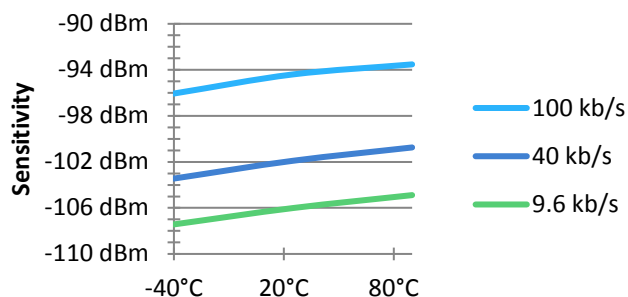

Figure 5: Typical Sensitivity (average over process corners)

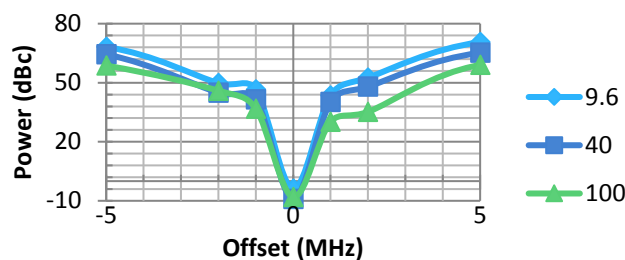

Figure 6: Typical Blocking performance

Blocking @40kbit/s, RSSI, LO leakage, intermodulation at V _{DD} = 3.3V, T _A = 25°C		Typ	Units
P _{BLOCK 1MHz}	Blocking at Δf=1MHz. Blocker level is defined relative to a wanted signal and measured with the wanted signal 3 dB above the sensitivity level	34	dBc
P _{BLOCK 2MHz}	Blocking at Δf=2MHz. Defined as above	38	dBc
P _{BLOCK 5MHz}	Blocking at Δf=5MHz. Defined as above	60	dBc
P _{BLOCK 10MHz}	Blocking at Δf=10MHz. Defined as above	63	dBc
P _{BLOCK 100MHz}	Blocking at Δf=100MHz. Defined as above	68	dBc
RSSI _{RANGE}	RSSI Dynamic Range	70	dB
RSSI _{LSB}	RSSI Resolution	1.5	dB
P _L	LO leakage	-80	dBm
IIP3	Intermodulation distortion product, third order interception point	-12	dBm

NOTES

1. All Z-Wave frequencies and modulation forms apply unless noted otherwise. Z-Wave frequencies currently span from 868.42MHz (EU) to 926MHz (Japan).
2. Crystal must be rated or calibrated to 32MHz ±25ppm.
3. Region specific impedance matching circuits according to reference designs applies.
4. Power level specifications are valid at the RF pin of the chip.

DIGITAL IO CHARACTERISTICS

IO pins have a nominal drive capability of 8mA (or 16mA) at the nominal 3.3V supply conditions. They are however fully functional down to 2.3V. Digital input pins, including all GPIO pins, features Schmitt trigger input hysteresis.

3.3V SYSTEMS

Output Pins, V _{DD} = 3.0V to 3.6V, T _A = -40 to +90°C		Min	Max	Units
V _{OH}	High level output voltage, sourcing 8mA	2.4		V
V _{OL}	Low level output voltage, sinking 8mA		0.4	V
T _{RISE}	Rise Time, 10% to 90%, 2pF external load		10	ns
T _{FALL}	Fall Time, 90% to 10%, 2pF external load		10	ns

Input Pins, V _{DD} = 3.0V to 3.6V, T _A = -40 to +90°C		Min	Max	Units
V _{IF}	Falling input trigger threshold	0.9	1.3	V
V _{IR}	Rising input trigger threshold	1.6	2.1	V
ΔV _I	Hysteresis	0.65	0.95	V
I _{IN}	Input current, 0V ≤ V _{IN} ≤ V _{DD} when internal pull-up is not available	-10	10	μA
I _{PULL UP}	Input current at V _{IN} =0V when internal pull-up is available	40	120	μA
C _{IN}	Input capacitance		10	pF

SUB 3V SYSTEMS

Output Pins, $V_{DD}= 2.3V$ to $3.0V$, $T_A = -40$ to $+90^\circ C$		Min	Max	Units
V_{OH}	High level output voltage, sourcing 6mA	1.9		V
V_{OL}	Low level output voltage, sinking 6mA		0.4	V

Input Pins, $V_{DD}= 2.3V$ to $3.0V$, $T_A = -40$ to $+90^\circ C$		Min	Max	Units
V_{IF}	Falling input trigger threshold	0.75	1.05	V
V_{IR}	Rising edge trigger threshold	1.35	1.85	V
ΔV_i	Hysteresis	0.55	0.85	V
I_{IN}	Input current, $0V \leq V_{IN} \leq V_{DD}$ when internal pull-up is not available	-7	7	μA
$I_{PULL UP}$	Input current at $V_{IN}=0V$ when internal pull-up is available	35	90	μA

TYPICAL IO CHARACTERISTICS, $V_{DD}= 2.3V$ TO $3.6V$, $T_A = -40$ TO $+90^\circ C$

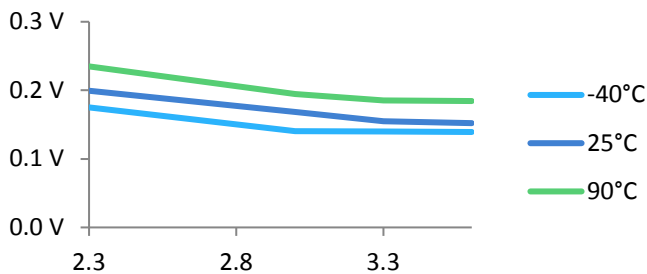

Figure 7: Output Voltage versus supply voltage when sinking 8mA

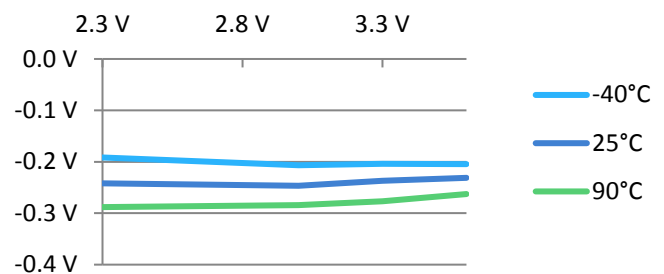

Figure 8: Output Voltage – VDD versus supply voltage when sourcing 8mA

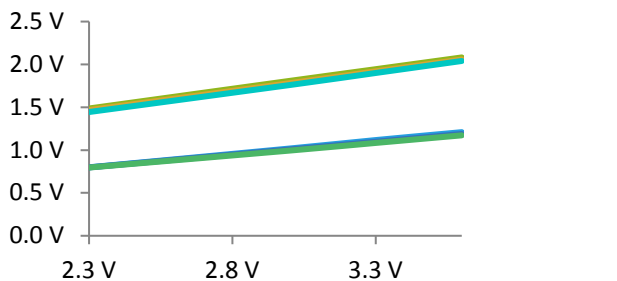

Figure 9: Input threshold voltages incl. hysteresis, versus supply voltage

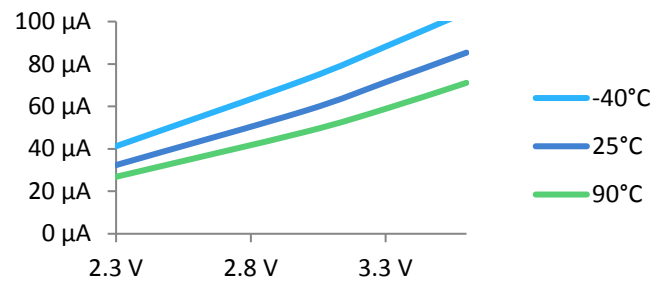

Figure 10: Input current at $V_{IN}=0V$ with pull-up activated, versus supply voltage

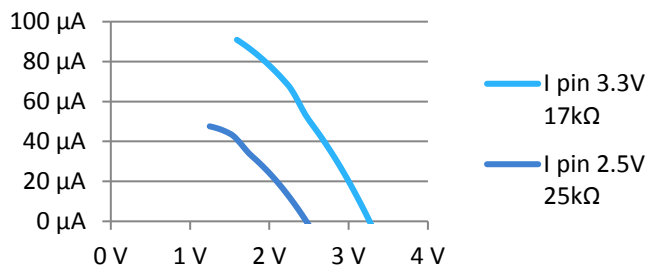

Figure 11: Internal pull up current versus pin voltage, 25°C, $V_{DD}=3.3V$ and $V_{DD}=2.5V$

Pull up resistance ranges 17kΩ to 25kΩ at 25°C.

BATTERY-ADC CHARACTERISTICS

12 bit A to D converter, $V_{DD} = 2.3$ to $3.6V$, $T_A = -40$ to $+90^\circ C$		Min	Max	Units
V_{BG}	Internal Voltage Reference, referenced to GND	1.2	1.3	V
	Differential non-linearity	-1	1	LSB
	Accuracy at sampling 10k samples per second at 12 bit resolution	-5	5	LSB
	Accuracy at sampling 20k samples per second at 8 bit resolution	-2	2	LSB

ABSOLUTE MAXIMUM RATINGS

Max Ratings		Min	Max	Units
V _{DD}	Supply voltage and other 3.3V rated pins as indicated in the Pin Descriptions section, page 18	-0.3	3.6	V
V _{IO}	Voltage applied on output pins	-0.3	5.5	V
V _{CORE}	Voltage applied on low-voltage analogue pins and other 1.5 V rated pins as indicated in the Pin Descriptions section, page 18	-0.3	1.8	V
P _{RF-IN}	RX input power		10	dBm
T _J	Operating Junction Temperature Range	-55	125	°C
T _{STORAGE}	Storage temperature range	-40	85	°C
I _{VDD MAX}	Max total continuous supply consumption		120	mA
V _{ESD-HBM}	All pins tested according to JESD22-A114 JEDEC Human Body Model JESD22-A114		2k	V
V _{ESD-CDM}	All pins tested according to JEDEC Charged Device Model JESD22-C101		500	V
I _{LatchUp}	IO pins Latch-Up Test JESD78, current stress		100	mA
V _{LatchUp}	Supply pins Latch-Up Test JESD78, voltage stress		5.4	V

NOTES

1. Stresses beyond those listed under “Max Ratings” may cause permanent damages to the device
2. These are stress ratings only. Functional operation of these devices beyond the ratings stated in the operational sections of the specifications is not implied.
3. Exposure to absolute maximum rating conditions for extended periods may affect device reliability.
4. TX matching network design will influence TX_{VRF PEAK} on TX output pin.
5. Caution: ESD sensitive device

PRODUCTION TEST CONDITIONS

The following conditions apply for the production final test unless noted otherwise.

1. Ambient temperature T_A = 25°C
2. Supply voltage V_{DD} = 3.3V
3. Crystal frequency = 32MHz
4. TX output power is measured at 900MHz
5. RX sensitivity is measured at 900.2MHz
6. All RF input and output levels referred to the pins of the chip (not the RF module).
7. Conditions include using production test schematic

QUALIFICATION TEST CONDITIONS

The following conditions apply for the qualification test unless noted otherwise.

1. Ambient temperature T_A = -40 to +90°C.
2. Supply voltage V_{DD} = 2.3 to 3.6V
3. Crystal frequency = 32MHz
4. RF performance measured across the span of Z-Wave frequencies
5. All RF input and output levels referred to the pins of the chip (not the RF module)
6. Conditions include using qualification test schematic
7. Conditions include using Z-Wave qualified RF drivers

OVERVIEW

With the Z-Wave protocol embedded, and a range of manufacturing blueprints of PCB circuitry that achieves proven RF performance at a low BOM, the SD3503 provides a low effort low risk solution for adding reliable and interoperable wireless RF-based communications technology to your product.

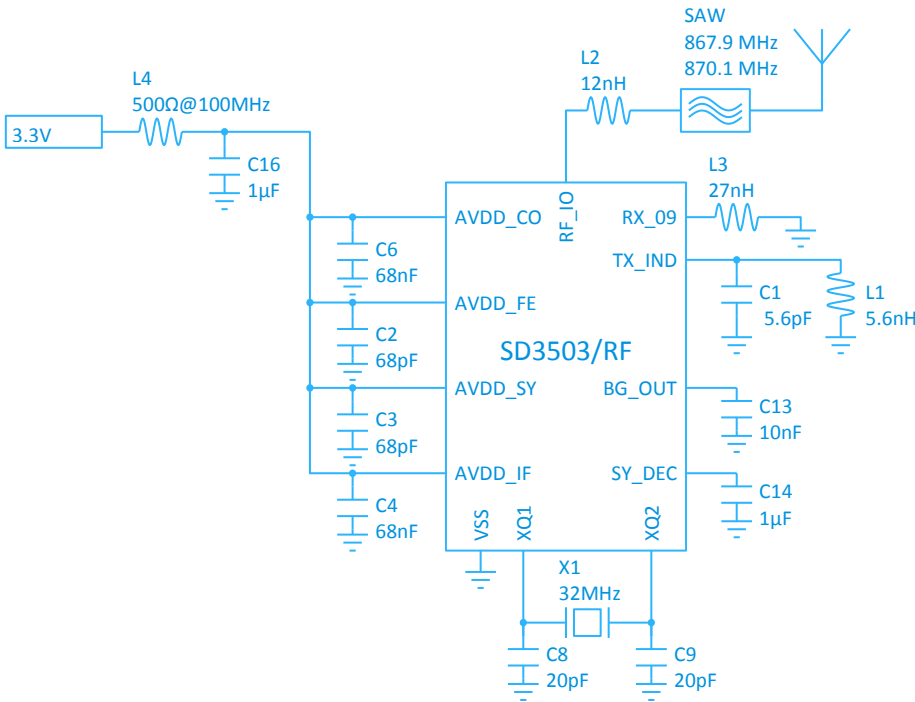

Figure 12: Schematic: Z-Wave RF enabled

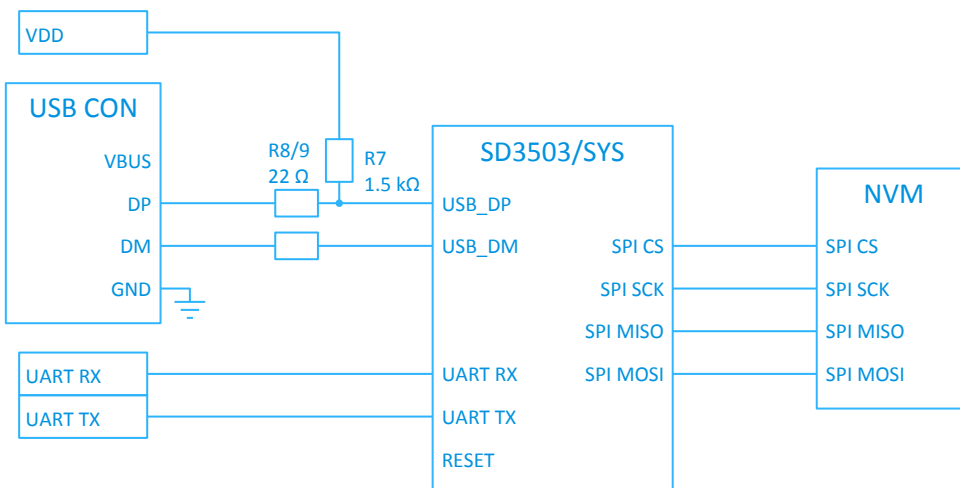

Figure 13 Schematic: System interfaces

WIRELESS TRANSCEIVER

The wireless Transceiver comprises a 3-channel 1GHz ISM FSK narrowband radio covering all currently used and projected Z-Wave frequencies, a modem, and a base band controller.

This architecture provides an all-digital direct synthesis transmitter and a low-IF digital receiver. The Z-Wave protocol currently utilizes two key FSK/GFSK modulation schemes and 9.6 / 40 / 100 kbit/s data rates throughout a span of carrier frequencies from 865.2 to 926 MHz.

The output power of the transmitter extends across the range of -21dBm to 5dBm, as set by your application, valid for $V_{DD} = 2.3$ to 3.6V, $T_A = -40$ to +90°C.

The software-controlled digital radio offers a wide selection of features: One, two, or three channel use, a frequency agility strategy applied to enhance network robustness, and power-saving RSSI usage. Regional enforced listen-before-talk constraints, data rate selection sets, signaling formats, and carrier frequencies can be configured to match the geographical region and product type targeted by your product build. This set of features expands gradually with new Z-Wave software releases to closely match the expanding diversity of products being added to the home control market group. For details, refer to the API documentation for the Z-Wave software applicable for your products.

Seen from an application builder’s perspective, the complexity of handling all these features, while ensuring full interoperability with existing products, are conveniently concealed behind the simple interface presented by the Z-Wave API.

INTERFACING THE FRONT-END

The reference designs include a few external components to optimally match the impedance of the PA (transmitter) and the LNA (receiver) to the 50 Ω antenna to be connected to the single-ended chip pin “RF_IO” . The SD3503 can be used with various types of antennas. Refer to document: ‘Antennas for Short Range Devices’. Suitable PCB wires often serve directly as the antenna, while helical, whip, and other antenna types are commonly seen where performance is emphasized.

Request manufacturing PCB blueprints for your target region and antenna choice.

Z-WAVE FREQUENCY COVERAGE

Region	Standard	Z-Wave Frequency
Australia	AS/NZS 4268	921.4 MHz
Brazil	ANATEL Resolution 506	921.4 MHz
CEPT¹	EN 300 220	868.4 MHz
Chile	FCC CFR47 Part 15.249	908.4 MHz
China	CNAS/EN 300 220	868.4 MHz
Hong Kong	HKTA 1035	919.8 MHz
India	N/A	865.2 MHz

¹ CEPT is the European regional organization dealing with postal and telecommunications issues and presently has 45 Members: Albania, Andorra, Austria, Azerbaijan, Belarus, Belgium, Bosnia and Herzegovina, Bulgaria, Croatia, Cyprus, Czech Republic, Denmark, Estonia, Finland, France, Germany, Greece, Hungary, Iceland, Ireland, Italy, Latvia, Liechtenstein, Lithuania, Luxembourg, Malta, Moldova, Monaco, Netherlands, Norway, Poland, Portugal, Romania, Russian Federation, San Marino, Serbia and Montenegro, Slovakia, Slovenia, Spain, Sweden, Switzerland, The former Yugoslav Republic of Macedonia, Turkey, Ukraine, United Kingdom, and Vatican.

Region	Standard	Z-Wave Frequency
Japan 950 ²	ARIB T96	951-956 MHz
Japan 920	ARIB STD-T108	922-926 MHz
Korea		919-923 MHz
Malaysia	SKMM WTS SRD/EN 300 220	868.1 MHz
Mexico	FCC CFR47 Part 15.249	908.4 MHz
New Zealand	AS/NZS 4268	921.4 MHz
Russia	GKRCh/EN 300 220	869.0 MHz
Singapore	TS SRD/EN 300 220	868.4 MHz
South Africa	ICASA/EN 300 220	868.4 MHz
Taiwan	NCC/LP0002	922-926 MHz
UAE	EN 300 220	868.4 MHz
USA/Canada	FCC CFR47 Part 15.249	908.4 MHz

CPU

The CPU is binary compatible with the industry standard 803x/805x CPU and is operated at 32MHz. Its cycle performance is improved by 6:1 to the standard 8051 implementation. Timers, SFRs, interrupt system, memories, IO devices, and other system components required to run Z-Wave Serial-API based applications and more are fully integrated.

The CPU processing power is shared between the Z-Wave MAC, higher level protocols and the user application.

MODES

The following modes of operations are supported:

ACTIVE	<ul style="list-style-type: none"> Code is executed Peripherals are available All I/O's are resistively pulled high Use a short (up to 4ms) low pulse on pin RESET_N to enter the reset of active state
PROGRAMMING DURING SUSTAINED RESET	<ul style="list-style-type: none"> Used to program the internal FLASH via UART Code is not executed All I/O's are resistively pulled high Programming requires external control of the reset pin and the UART port
APM PROGRAMMING	<ul style="list-style-type: none"> Used to program the internal FLASH via USB or UART, often initiated from an API call Code is not executed All I/O's are resistively pulled high Access to the reset pin is not required The chip can be configured to reset into this state either using an API call or instructed via the programming interface.

² In February 2012, Japanese regulatory body ARIB (Association of Radio Industries and Businesses) released new 920 MHz frequency band for radio equipment, due to LTE rollout. The 950 MHz frequency band will be obsolete by end of 2015.

- EXTERNAL NVM PROGRAMMING**
- Used to program an external NVM (FLASH/EPROM) (optionally) wired to the SPI port
 - Code is not executed
 - All I/O's are resistively pulled high
 - External NVM programming requires external control of the reset pin (plus the NVM-SPI port)

PROGRAMMING MODE

The code space and the NVR pages of the flash can be read and programmed through the UART and the USB interface. With proper (optional) Z-Wave software loaded into the Flash, Over-The-Air reprogramming will be available to your application.

ENTERING PROGRAMMING MODE

To enter programming mode, assert the RESET_N pin low for 5.2ms. The chip will then listen on the UART port for a correct initiating command.

Additionally, an API function is available that configures the chip to enter programming mode after next reset (hardware- or software-initiated). In this state only, the chip begins listening for the initiating string on the USB port as well as on the UART.

PERIPHERALS AND AUXILIARY BLOCKS

The peripherals and auxiliary blocks, other than the Z-Wave radio already outlined on page 12, will be explained in the following sections.

SUPPLY SYSTEM

The chip is powered from a single 2.3 – 3.6 V supply.

When using the schematic in Figure 14, an internal Power-On-Reset circuit guarantees that execution never begins unless the supply voltage is sufficient. The internal Brown-Out-Reset (BOR) circuit guarantees that the chip is always reset before insufficient voltage levels cause execution to fail. These guarantees apply equally in all active and power-down modes. Further, there is no restriction on power-up rise time to consider when designing an application.

On-chip supply regulators derive all the 1.5 V and 2.5 V internal supplies needed by MCU core logic, data persistency registers, the flash, and the analogue circuitry. Decoupling capacitors are required as indicated.

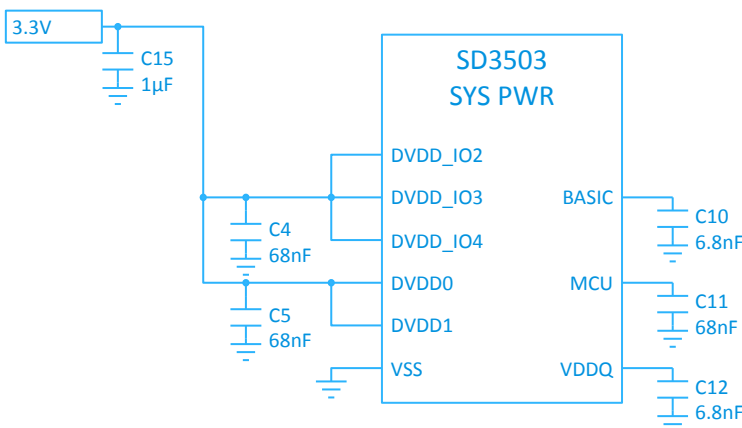

Figure 14: Supply related external components

Note that digital IO circuits are powered unregulated via the supply pins. As a consequence, for the internal USB PHY to be signaling level compliant when in use, the supply must be set to 3.0 – 3.6 V.

XTAL AND SYSTEM CLOCK

The SD3503 derives RF frequencies and MCU clocks from an external 32MHz crystal (XTAL) as shown in Figure 12: Schematic: Z-Wave RF enabled on page 11.

Refer to your crystal component supplier for suitable load capacitance values, or refer to the BOM on our published reference designs.

PRODUCTION CONSIDERATIONS

Silicon Labs specifies application of a reference clock during the system test/calibration step to guarantee initial frequency precision. Request the applicable application note. A built-in frequency calibration circuit compensates for initial crystal frequency offsets of up to ±100 ppm.

The temperature and 5 years aging margin for the 32MHz crystal is 15 ppm.

To ensure frequency shift keying is kept within the 10% accuracy range specified by ITU-T G.9959, the device should be allowed to self-calibrate using a procedure built into all supported programmers.

WAKE-UP-TIMER

The max 200nA built-in WUT (Wake Up Timer) plays an important role in maximizing battery life of applications like Frequently Listening Routing Slave (FLIRS) Z-Wave nodes. The WUT is also available to customer applications, and may be programmed to wake a sleeping node after 0 to 256 seconds of sleep. The programming resolution equals 8 bit fractions of 2 seconds, alternatively 8 bit fractions of 256 seconds.

The WUT is autonomously calibrated to the system clock (whenever this is running) and maintains a better than 2% precision.

BATTERY MONITOR ADC

The monitor raises an interrupt if a lower or an upper warning supply threshold is exceeded. The sample rate versus accuracy tradeoff options (in continuous mode) are:

- 20 kHz 8 bit mode
- 10 kHz 12 bit mode

SPI

A Serial Peripheral Interface (SPI) is available on pins 14, 16-18. The SPI enables synchronous data transfers between this and slave SPI devices.

Pin	SPI Pin	SPI Function, master
Pin 18	MOSI	Data output
Pin 17	MISO	Data input
Pin 16	SCK	Clock output
Pin 14	SS	Slave Selects output

During data transmission, the SCK pin act as a clock. 8 bit of data will be exchanged between the two devices after 8 cycles of SCK as shown in Figure 15.

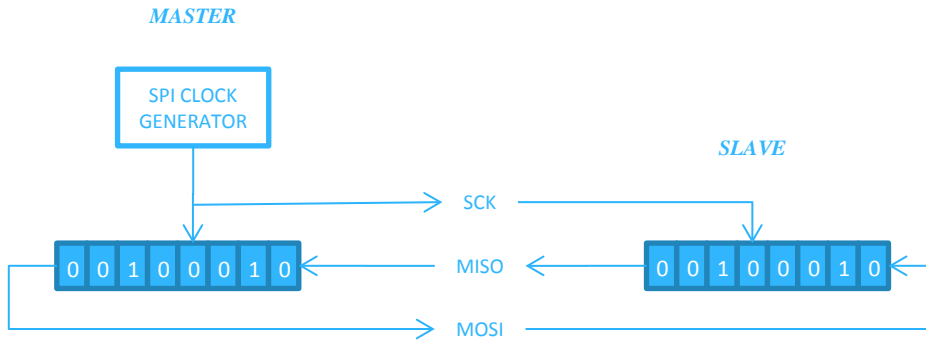

Figure 15 Flow of data between master and slave when correctly connected

The chip operates as a SPI master when controlling an external EEPROM and similar devices.

UART

The chip has a full duplex 9.6 to 230.4 kbit/s UART hardware block operating independently of the CPU, thus not using timer resources as in the classic 8051 MCU.

The UART interface is available on pins 19-20. Figure 16 shows a typical RS232 UART application.

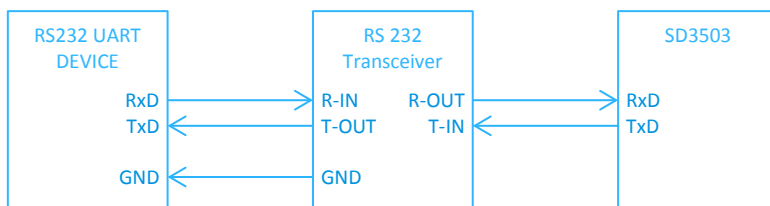

Figure 16: UART application example

The UART shifts data in/out in the following order: start bit, data bits (LSB first) and stop bit. Figure 17 gives the waveform of a serial byte.



Figure 17 UART waveform

The device can be programmed using the USB interface.

USB

The built-in USB2.0 device controller and PHY support 12Mbit/s. Three resistors should be inserted between the USB connector and the chip, as shown in Figure 13 Schematic: System interfaces on page 11.

The USB controller implements an interface with two CDC/ACM compliant ports, and can be setup to use the built-in drivers of Windows etc. It supports a custom USB string for helping the driver doing predictable identification. Setup and enumeration is handled in hardware, and data access is sent to predefined memory buffers in the 4K SRAM using DMA. The data is CRC protected, and automatically retransmitted on error, buffer full, etc.

The device can be programmed using the USB interface.

USB-BUS-POWERED AND SUSPEND-MODE SUPPORT

The USB controller supports suspend mode and remote wakeup. The crystal remains powered and the CPU may continue to run at a reduced clock frequency during suspend.

The USB 2.0 spec allows connected devices to be powered via the USB. Devices are each allowed a minimum of 100mA during non-suspend periods, and 2.5mA (average) (after proper enumeration) during suspend periods. The USB 2.0 supply ranges from 4.4 V to 5.25 V. This allows SD3502 based systems to be entirely powered by the USB using simple linear regulators. The power budget margin even allows such systems to resume full Z-Wave network presence on a frequent basis even when placed in USB suspend state.

AES SECURITY PROCESSOR

The Z-Wave protocol specifies the use of AES 128-bit block encryption in secured applications.

The built-in Security Processor is a hardware accelerator that encrypts and decrypts data at a rate of 1 byte per 1.5 μ s. It encodes the frame payload and the message authentication code to ensure privacy, integrity, and authenticity on messages.

The processor supports OFB, CBC (and ECB) modes to target variable length messages. Payload data is streamed in OFB mode, and authentication data is processed in CBC mode as required by the Z-Wave protocol.

The processor implements two efficient access methods: DMA and streaming through SFR ports. The processor is exposed via the API for additional custom use.

RESET

A RESET causes the MCU to be powered, clocked, initialized, and started.

The delay associated with a RESET is less than 1 ms using any of our reference designs, and is mostly spent on charging the supply capacitances (internal as well as external) and bringing the XTAL clock into a stable and confirmed oscillation.

Multiple events may cause a reset of the chip. The actual cause is latched by hardware and may be retrieved via SW when the system resumes operation. The table lists the supported reset methods.

Some reset methods deliberately leaves the state of IO pins untouched. Other IO pins are reset to its input state with pull-up activated.

Reset Cause	Description	Effect on IO state
POR	Reset request generated by Power-On-Reset hardware	Reset
BOR	Reset request generated by Brown-Out-Reset hardware	Reset
RESET_N	Reset request generated by the RESET_N pin being de-asserted	Reset
WUT	Reset request generated by the Wake-Up-Timer timing out	Untouched
WATCHDOG	Reset request generated by the WATCHDOG Timer timing out	Reset
Software	Reset by software	Untouched

PIN DESCRIPTIONS

PINS: 900 MHZ Z-WAVE RADIO

Function	Pad identification	Type
Antenna	Pin 4: RF IO	1.5V RF analogue
Connection points for RF impedance matching components	Pin 3: RF Tx inductor	1.5V RF analogue
	Pin 5: RF Rx 900MHz inductor	1.5V RF analogue
Connection points for other external components needed to support Z-Wave (e.g. capacitors)	Pin 2: Power for RF front end	1.5V analogue
	Pin 6: Power for synthesizer and bandgab	1.5V analogue
	Pin 8: BandGab voltage OUT	1.5V analogue
	Pin 7: Synthesizer Decoupler Capacitor	1.5V analogue
	Pin 9: Power for analog IF	1.5V analogue
	Pin 31: Power for analog core	1.5V analogue

PINS: SYSTEM INTERFACE

Function	Pad identification	Type
USB	Pin 24: USB negative IO	3.3V IO
	Pin 25: USB positive IO	3.3V IO
UART	Pin 20: UART 0 RX	3.3V IO
	Pin 19: UART 0 TX	3.3V IO
SPI (for serial Flash)	Pin 18: SPI 0 MOSI	3.3V IO
	Pin 17: SPI 0 MISO	3.3V IO
	Pin 16: SPI 0 SCK	3.3V IO
	Pin 14: SS	3.3V IO
System reset	Pin 15: RESET_N	3.3V IO
Clock XTAL	Pin 1: Clock Oscillator output	1.5V analogue
	Pin 32: Clock Oscillator input	1.5V analogue
Power supply 3.3V	Pin 21: Digital IO Power	3.3V Supply
	Pin 22: Digital IO Power	3.3V Supply
	Pin 26: Digital IO Power	3.3V Supply
	Pin 27: Digital domain power	3.3V Supply
	Pin 28: Digital domain power	3.3V Supply
Connection points for other external components needed to support the system (e.g. capacitors)	Pin 23: Power for Flash	2.5V
	Pin 29: Internal Power 1.5V	1.5V
	Pin 30: Internal Power 1.5V	1.5V

PINS PER PIN NUMBER

No	Name	Type	Description
pin 1	XOSC_Q2	IO for XTAL	Clock Oscillator (output)
pin 2	AVDD_FE	VDD 3.3V	Power for RF front end
pin 3	TX_IND	Analogue RF	RF Tx inductor
pin 4	RF_IO	Analogue RF IO	RF IO (antenna path)
pin 5	RX_09	Analogue RF	RF RX 900MHz inductor
pin 6	AVDD_SY	VDD 3.3V	Power for synthesizer and bandgap
pin 7	SY_DECOUP	1.5V Internal supply	Synthesizer supply
pin 8	BG_OUT	Analogue 1.5V domain	Bandgap voltage OUT
pin 9	AVDD_IF	VDD 3.3V	Power for analog IF
pin 10	N.C.	N.C.	Not Connected
pin 11	N.C	N.C.	Not Connected. Reserved.
Pin 12	N.C	N.C.	Not Connected. Reserved.
pin 13	N.C.	N.C.	Not Connected
pin 14	P1_5	3.3V digital IO	SPI0 CS (active low)
pin 15	RESET_N	3.3V digital IO	System reset / pgm interface ³
pin 16	P2_7	3.3V digital IO	SPI0 SCK
pin 17	P2_6	3.3V digital IO	SPI0 MISO
pin 18	P2_5	3.3V digital IO	SPI0 MOSI
pin 19	P2_1	3.3V digital IO	UART0 TX / pgm interface
pin 20	P2_0	3.3V digital IO	UART0 RX / pgm interface
pin 21	DVDD_IO2	VDD 3.3V	Digital IO power 2 / pgm interface
pin 22	DVDD_IO3	VDD 3.3V	Digital IO power 3
pin 23	VDDQ	Analogue IO 3.3V domain	Power for Flash (output of charge pump)
pin 24	USB_DM	3.3V digital IO	USB negative diff IO / USB ISP
pin 25	USB_DP	3.3V digital IO	USB positive diff IO / USB ISP / pgm interface (calibration)
pin 26	DVDD_IO4	VDD 3.3V	Digital IO power 4
pin 27	DVDD0	VDD 3.3V	Digital domain power 0
pin 28	DVDD1	VDD 3.3V	Digital domain power 1
pin 29	MCU	1.5V Internal supply	Internal Power 1.5V (MCU)
pin 30	BASIC	1.5V Internal supply	Internal Power 1.5V (BASIC)
pin 31	AVDD_AC0	VDD 3.3V	Power for Analog core
pin 32	XOSC_Q1	IO for XTAL	Clock Oscillator (input)
Exposed	GND	GND	Exposed center pad/ pgm interface

PROCESS SPECIFICATION

Specification	Description
MSL 3	Moisture Sensitivity Level tested according to JEDEC J-STD-020C
REACH	REACH is a European Community Regulation on chemicals and their safe use (EC 1907/2006). It deals with the Registration, Evaluation, Authorisation and Restriction of Chemical substances
RoHS	Designed in compliance with The Restriction of Hazardous Substances Directive (RoHS)

³ The pins marked “/ pgm interface” constitute the programming and debugging interface. This interface must be exposed to the programmer if In-System Programming is required. Please refer to INS12213 Instruction: 500 Series Integration Guide.

PCB MOUNTING AND SOLDERING

RECOMMENDED PCB MOUNTING PATTERN

Please follow standard QFN mounting pattern.

SOLDERING INFORMATION

The soldering details to properly solder the SD3502 module on standard PCBs are described below. The information provided is intended only as a guideline and Silicon Labs is not liable if a selected profile does not work.

See IPC/JEDEC J-STD-020D.1 for more information.

PCB solder mask expansion from landing pad edge	0.1 mm
PCB paste mask expansion from landing pad edge	0.0 mm
PCB process	Pb-free (Lead free for RoHS ⁴ compliance)
PCB finish	Defined by the manufacturing facility (EMS) or customer
Stencil aperture	Defined by the manufacturing facility (EMS) or customer
Stencil thickness	Defined by the manufacturing facility (EMS) or customer
Solder paste used	Defined by the manufacturing facility (EMS) or customer
Flux cleaning process	Defined by the manufacturing facility (EMS) or customer

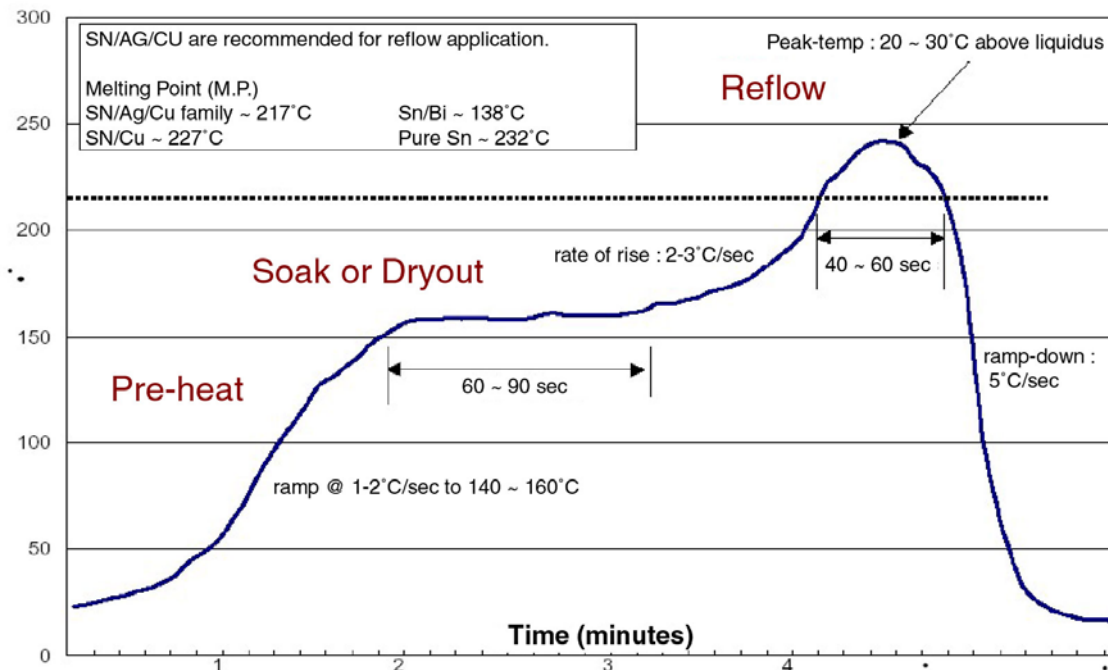

Figure 18 Recommended Reflow Temperature Profile

⁴ RoHS = Restriction of Hazardous Substances Directive, EU

ORDERING INFORMATION

Part Number	Product Description
SD3503A-CNE3R	2000 pcs QFN 32 pins 5x5 mm on reel

PACKAGE

QFN 32 PINS 5X5 MM

Caution: Moisture sensitive device MSL-3 defined by IPC/JEDEC J-STD-020. May require bake before mounting after bag is opened.

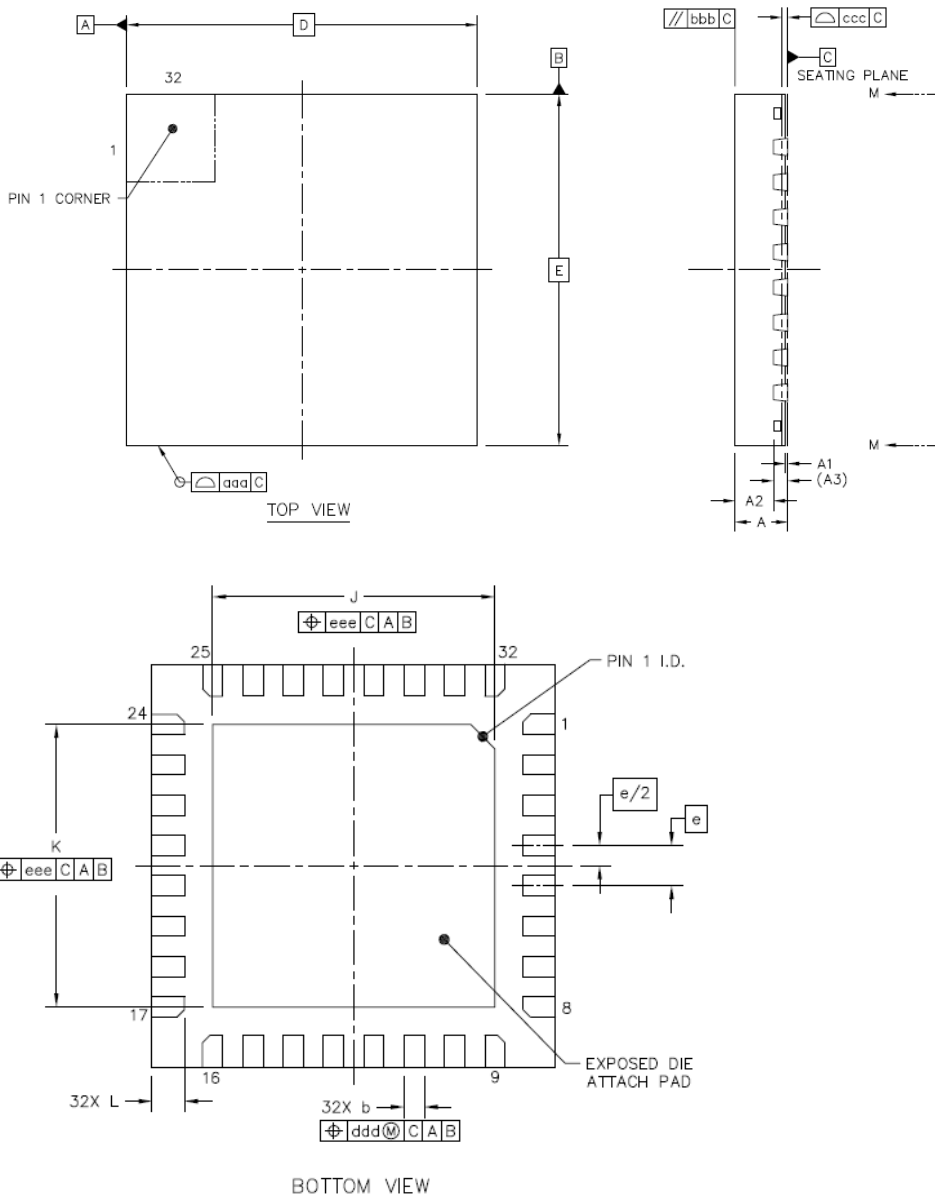

Symbol	Min	Nom	Max
--------	-----	-----	-----

Total thickness	A	0.7	0.75	0.8
Stand off	A1	0	0.035	0.05
Mold thickness	A2	---	0.55	0.57
L/F thickness	A3		0.203 REF	
Leak width	b	0.2	0.25	0.3
Body size	D (x)		5 BSC	
	E (y)		5 BSC	
Lead pitch	e		0.5 BSC	
EP size	J (x)	3.4	3.5	3.6
	K (y)	3.4	3.5	3.6
Lead length	L	0.35	0.4	0.45
Package edge tolerance	aaa		0.1	
Mold flatness	bbb		0.1	
Co-planarity	ccc		0.08	
Lead offset	ddd		0.1	
Exposed pad offset	eee		0.1	

REEL

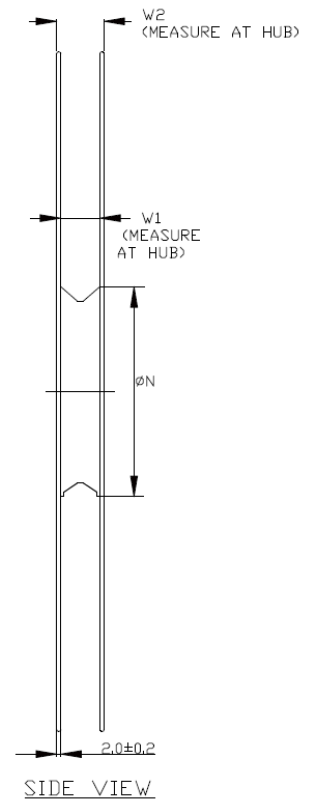
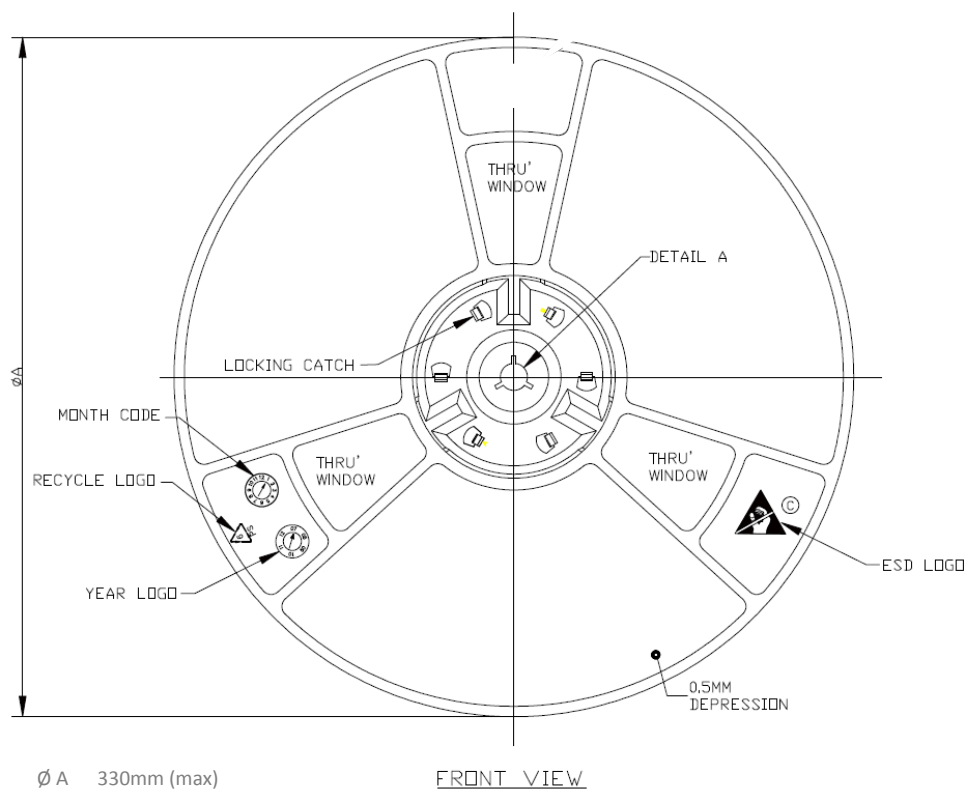

W1 12.4mm – 12.6mm
 W2 18.4mm (max)
 ϕN 100mm (min)

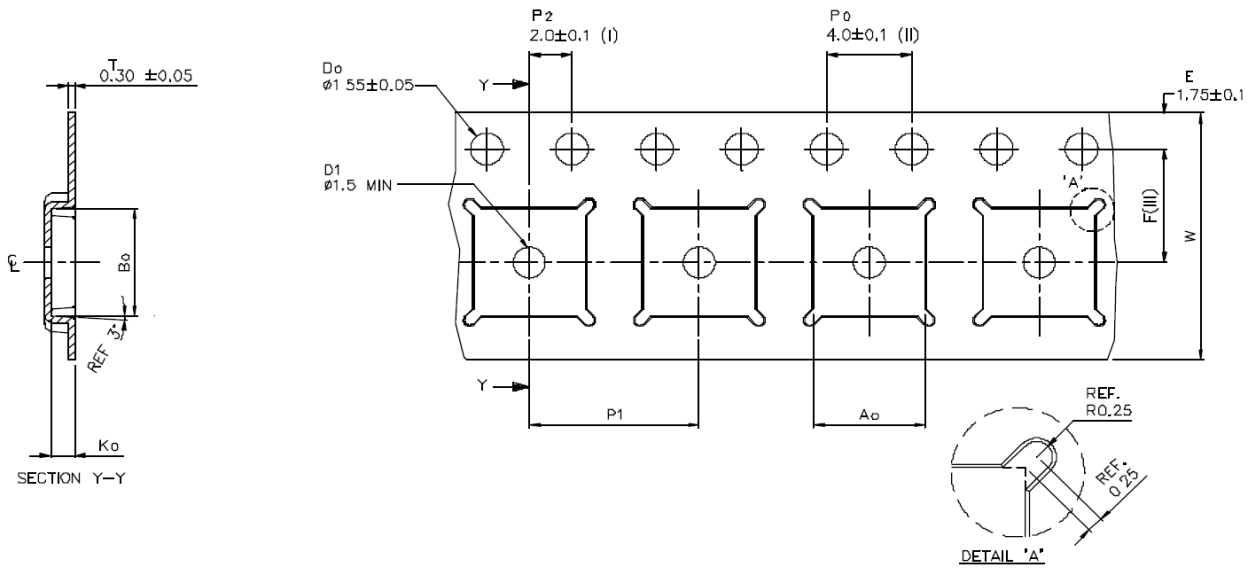

A ₀	5.25 +/- 0.1
B ₀	5.25 +/- 0.1
K ₀	1.10 +/- 0.1
F	5.50 +/- 0.1
P ₁	8.00 +/- 0.1
W	12.00 +/- 0.3

- (I) Measured from centreline of sprocket hole to centreline of pocket.
- (II) Cumulative tolerance of 10 sprocket holes is ± 0.20 .
- (III) Measured from centreline of sprocket hole to centreline of pocket.
- (IV) Other material available.

ALL DIMENSIONS IN MILLIMETRES UNLESS OTHERWISE STATED.

QUADRANT ASSIGNMENTS FOR PIN 1 ORIENTATION IN TAPE

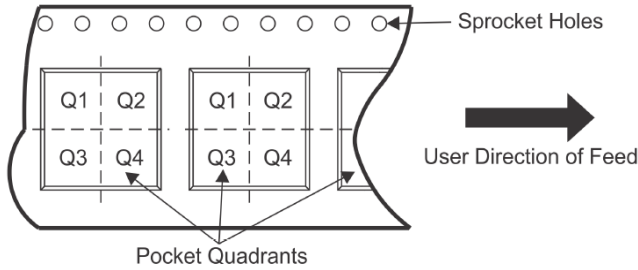

Parameter	Value
Pin 1 Quadrant	Pocket Quadrant Q1

TOP MARKING

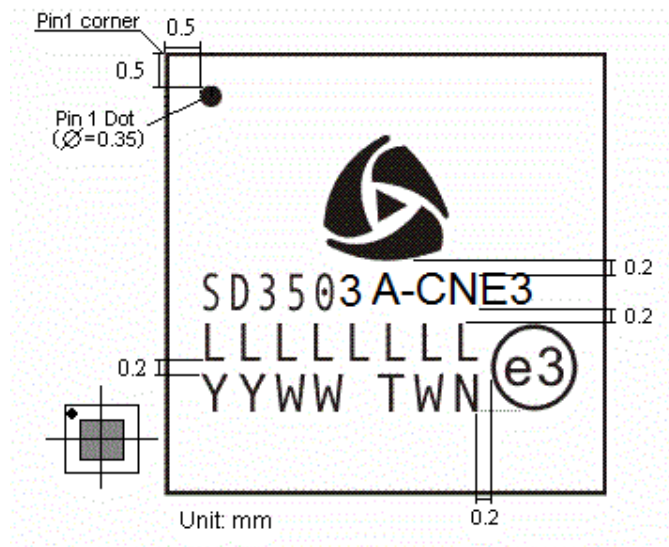

Marking	Meaning
SD3503	Product number
A	Product revision
C	Commercial temperature range
N	QFN package
E3	Green BOM
LLLL...	Wafer lot
YYWW TWN	YY [year]
	WW [week]
	TWN [Country of Origin]

DOCUMENT CHANGE LIST

Version	Date	By	Pages affected	Description of changes
1	2013-02-22	PNI	All	Initial draft
2	2013-05-13	PNI	7	Sensitivity versus Temperature graph added
3	2013-05-17	PNI	7	Added typical current consumption versus TX power
			All	Edits from technical writer committed
4	2013-05-31	PNI	8-9	IO data updated
5	2013-06-03	PNI	All	Repaired header and footers
6	2013-08-16	PNI	19-21	Ordering info updated, changing to reels
7	2013-09-30	PNI	9	Pull up resistor characteristics added
8	2013-10-14	PNI	18-19	Package drawing and dim table replaced
9	2013-11-29	PNI	6	Added typical blocking versus bit rate
10	2013-11-12	PNI	13-14	Operating modes section updated
11	2014-01-05	PNI	18	Pin list table inserted
12	2014-03-11	PNI	18	P/N now appended with an R (to emphasize the Reel packaging)
13	2014-03-14	PNI	18	RESET0_N corrected to RESET_N
13	2014-04-22	PNI	9, 18-19	Storage temperature added, programming pin notifications, MSL3 specified
13	2014-04-28	PNI	11-12	Table "Z WAVE FREQUENCY COVERAGE" updated
14	2014-06-11	PNI	12	Improper reference to SPI deleted
15	2015-03-27	MHANSEN	20	Added section PCB mounting and soldering
			19	Added section Process Specification
			23	Added orientation of component in tape

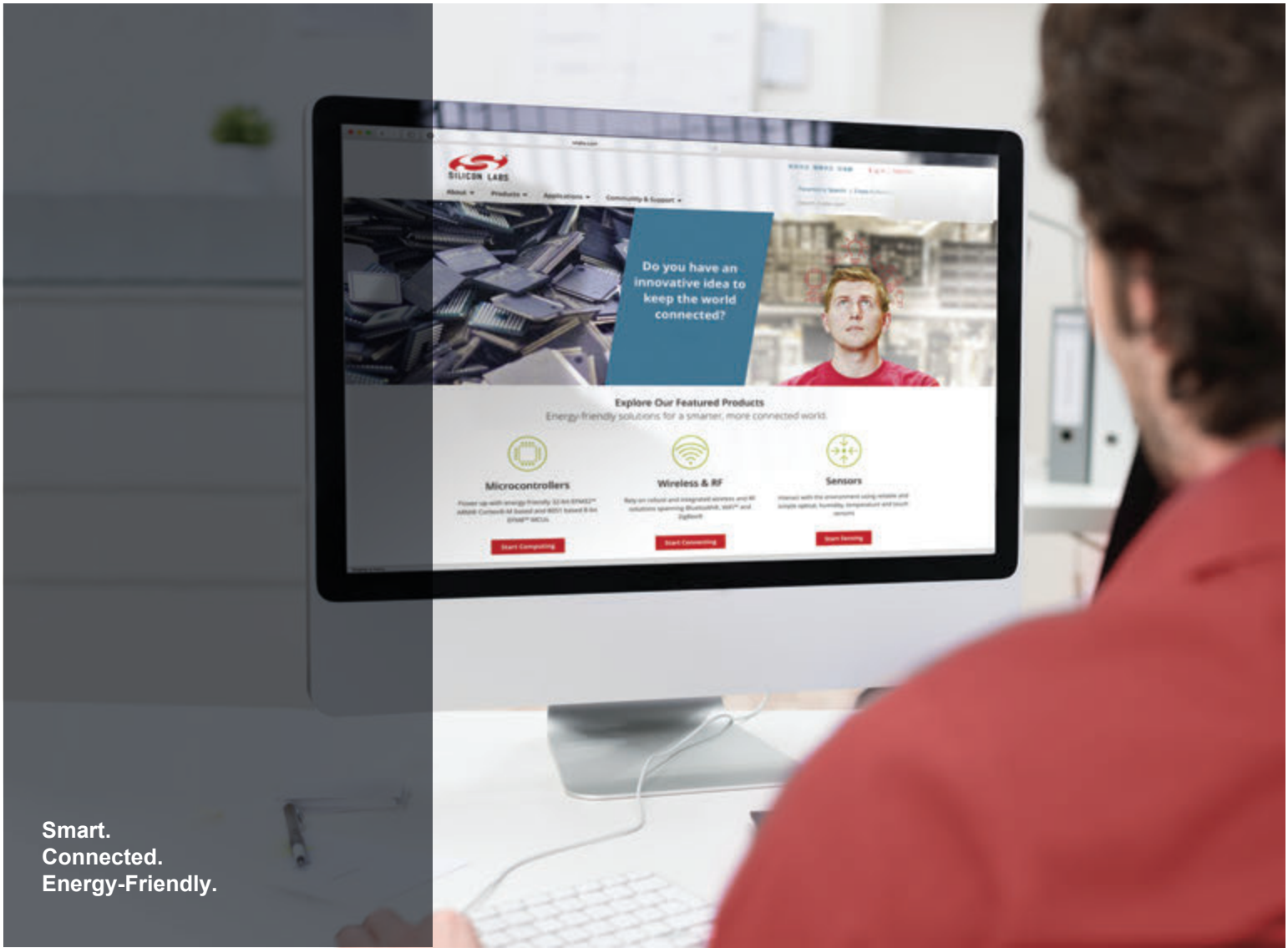

Smart.
Connected.
Energy-Friendly.



Products
www.silabs.com/products

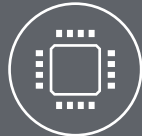

Quality
www.silabs.com/quality



Support and Community
community.silabs.com

Disclaimer

Silicon Labs intends to provide customers with the latest, accurate, and in-depth documentation of all peripherals and modules available for system and software implementers using or intending to use the Silicon Labs products. Characterization data, available modules and peripherals, memory sizes and memory addresses refer to each specific device, and "Typical" parameters provided can and do vary in different applications. Application examples described herein are for illustrative purposes only. Silicon Labs reserves the right to make changes without further notice and limitation to product information, specifications, and descriptions herein, and does not give warranties as to the accuracy or completeness of the included information. Silicon Labs shall have no liability for the consequences of use of the information supplied herein. This document does not imply or express copyright licenses granted hereunder to design or fabricate any integrated circuits. The products are not designed or authorized to be used within any Life Support System without the specific written consent of Silicon Labs. A "Life Support System" is any product or system intended to support or sustain life and/or health, which, if it fails, can be reasonably expected to result in significant personal injury or death. Silicon Labs products are not designed or authorized for military applications. Silicon Labs products shall under no circumstances be used in weapons of mass destruction including (but not limited to) nuclear, biological or chemical weapons, or missiles capable of delivering such weapons.

Trademark Information

Silicon Laboratories Inc.®, Silicon Laboratories®, Silicon Labs®, SiLabs® and the Silicon Labs logo®, Bluegiga®, Bluegiga Logo®, Clockbuilder®, CMEMS®, DSPLL®, EFM®, EFM32®, EFR®, Ember®, Energy Micro, Energy Micro logo and combinations thereof, "the world's most energy friendly microcontrollers", Ember®, EZLink®, EZRadio®, EZRadioPRO®, Gecko®, ISOmodem®, Micrium, Precision32®, ProSLIC®, Simplicity Studio®, SiPHY®, Telegesis, the Telegesis Logo®, USBXpress®, Zentri, Z-Wave and others are trademarks or registered trademarks of Silicon Labs. ARM, CORTEX, Cortex-M3 and THUMB are trademarks or registered trademarks of ARM Holdings. Keil is a registered trademark of ARM Limited. All other products or brand names mentioned herein are trademarks of their respective holders.



SILICON LABS

Silicon Laboratories Inc.
400 West Cesar Chavez
Austin, TX 78701
USA

<http://www.silabs.com>