

DATA SHEET

SA616

Low-voltage high performance mixer
FM IF system

Product specification
Replaces data of 1993 Dec 15
IC17 Data Handbook

1997 Nov 07

Low-voltage high performance mixer FM IF system

SA616

DESCRIPTION

The SA616 is a low-voltage high performance monolithic FM IF system incorporating a mixer/oscillator, two limiting intermediate frequency amplifiers, quadrature detector, logarithmic received signal strength indicator (RSSI), voltage regulator and audio and RSSI op amps. The SA616 is available in 20-lead SSOP (shrink small outline package).

The SA616 was designed for portable communication applications and will function down to 2.7V. The RF section is similar to the famous SA615. The audio and RSSI outputs have amplifiers with access to the feedback path. This enables the designer to adjust the output levels or add filtering.

FEATURES

- Low power consumption: 3.5mA typical at 3V
- Mixer input to >150MHz
- Mixer conversion power gain of 17dB at 45MHz
- XTAL oscillator effective to 150MHz (L.C. oscillator or external oscillator can be used at higher frequencies)
- 102dB of IF Amp/Limiter gain
- 2MHz IF amp/limiter small signal bandwidth
- Temperature compensated logarithmic Received Signal Strength Indicator (RSSI) with a 80dB dynamic range
- Low external component count; suitable for crystal/ceramic/LC filters
- Excellent sensitivity: 0.31 μ V into 50 Ω matching network for 12dB SINAD (Signal to Noise and Distortion ratio) for 1kHz tone with RF at 45MHz and IF at 455kHz
- SA616 meets cellular radio specifications
- Audio output internal op amp
- RSSI output internal op amp
- Internal op amps with rail-to-rail outputs
- ESD protection: Human Body Model 2kV
Robot Model 200V

ORDERING INFORMATION

DESCRIPTION	TEMPERATURE RANGE	ORDER CODE	DWG #
20-Pin Plastic Shrink Small Outline Package (SSOP) (Surface-mount)	-40 to +85°C	SA616DK	SOT266-1

ABSOLUTE MAXIMUM RATINGS

SYMBOL	PARAMETER	RATING	UNITS
V _{CC}	Single supply voltage	7	V
T _{STG}	Storage temperature range	-65 to +150	°C
T _A	Operating ambient temperature range	-40 to +85	°C
θ_{JA}	Thermal impedance DK package	117	°C/W

PIN CONFIGURATION

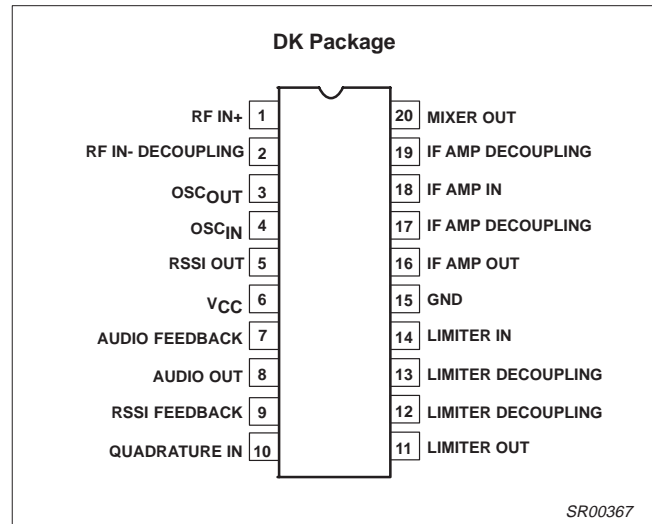

Figure 1. Pin Configuration

APPLICATIONS

- Portable cellular radio FM IF
- Cordless phones
- Wireless systems
- RF level meter
- Spectrum analyzer
- Instrumentation
- FSK and ASK data receivers
- Log amps
- Portable high performance communication receiver
- Single conversion VHF receivers

Low-voltage high performance mixer FM IF system

SA616

BLOCK DIAGRAM

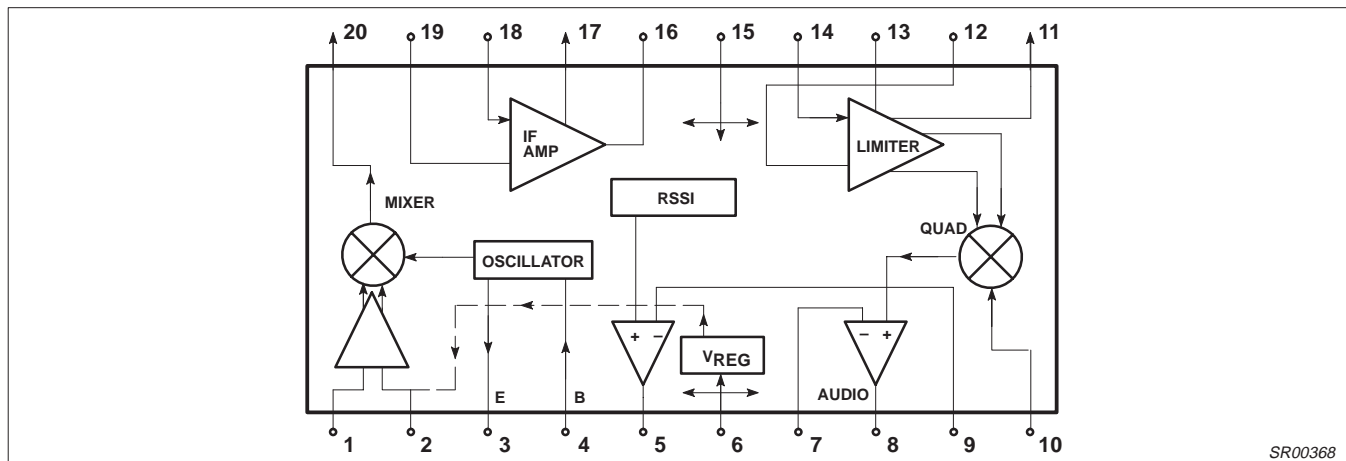

Figure 2. Block Diagram

DC ELECTRICAL CHARACTERISTICS

$V_{CC} = +3V$, $T_A = 25^\circ C$; unless otherwise stated.

SYMBOL	PARAMETER	TEST CONDITIONS	LIMITS			UNITS
			MIN	TYP	MAX	
V_{CC}	Power supply voltage range		2.7		7.0	V
I_{CC}	DC current drain			3.5	5.0	mA

AC ELECTRICAL CHARACTERISTICS

$T_A = 25^\circ C$; $V_{CC} = +3V$, unless otherwise stated. RF frequency = 45MHz + 14.5dBV RF input step-up; IF frequency = 455kHz; R17 = 2.4k Ω and R18 = 3.3k Ω ; RF level = -45dBm; FM modulation = 1kHz with ± 8 kHz peak deviation. Audio output with de-emphasis filter and C-message weighted filter. Test circuit Figure 3. The parameters listed below are tested using automatic test equipment to assure consistent electrical characteristics. The limits do not represent the ultimate performance limits of the device. Use of an optimized RF layout will improve many of the listed parameters.

SYMBOL	PARAMETER	TEST CONDITIONS	LIMITS			UNITS
			MIN	TYP	MAX	
Mixer/Osc section (ext LO = 220mV_{RMS})						
f_{IN}	Input signal frequency			150		MHz
f_{OSC}	Crystal oscillator frequency			150		MHz
	Noise figure at 45MHz			6.8		dB
	Third-order input intercept point (50 Ω source)	f1 = 45.0; f2 = 45.06MHz Input RF level = -52dBm		-9		dBm
	Conversion power gain	Matched 14.5dBV step-up	11	17		dB
		50 Ω source		+2.5		dB
	RF input resistance	Single-ended input		8		k Ω
	RF input capacitance			3.0	4.0	pF
	Mixer output resistance	(Pin 20)	1.25	1.5		k Ω
IF section						
	IF amp gain	50 Ω source		44		dB
	Limiter gain	50 Ω source		58		dB
	Input limiting -3dB, R _{17a} = 2.4k, R _{17b} = 3.3k	Test at Pin 18		-105		dBm
	AM rejection	80% AM 1kHz		40		dB
	Audio level	Gain of two (2k Ω AC load)	60	120		mV
	SINAD sensitivity	IF level -110dBm		17		dB
THD	Total harmonic distortion		-30	-45		dB

Low-voltage high performance mixer FM IF system

SA616

AC ELECTRICAL CHARACTERISTICS (Continued)

SYMBOL	PARAMETER	TEST CONDITIONS	LIMITS			UNITS
			MIN	TYP	MAX	
S/N	Signal-to-noise ratio	No modulation for noise		62		dB
	RF RSSI output, $R_g = 2k\Omega$	RF level = -118dBm		0.3	.80	V
		RF level = -68dBm	.70	1.1	2	V
		RF level = -23dBm	1.0	1.8	2.50	V
	RSSI range			80		dB
	RSSI accuracy			± 2		dB
	IF input impedance	Pin 18	1.3	1.5		$k\Omega$
	IF output impedance	Pin 16		0.3		$k\Omega$
	Limiter input impedance	Pin 14	1.3	1.5		$k\Omega$
	Limiter output impedance	Pin 11		0.3		$k\Omega$
	Limiter output voltage	Pin 11		130		mV _{RMS}
RF/IF section (int LO)						
	Audio level	$3V = V_{CC}$, RF level = -27dBm		120		mV _{RMS}
	System RSSI output	$3V = V_{CC}$, RF level = -27dBm		2.2		V
	System SINAD sensitivity	RF level = -117dBm		12		dB

CIRCUIT DESCRIPTION

The SA616 is an IF signal processing system suitable for second IF systems with input frequency as high as 150MHz. The bandwidth of the IF amplifier and limiter is at least 2MHz with 90dB of gain. The gain/bandwidth distribution is optimized for 455kHz, 1.5k Ω source applications. The overall system is well-suited to battery operation as well as high performance and high quality products of all types.

The input stage is a Gilbert cell mixer with oscillator. Typical mixer characteristics include a noise figure of 6.2dB, conversion gain of 17dB, and input third-order intercept of -9dBm. The oscillator will operate in excess of 200MHz in L/C tank configurations. Hartley or Colpitts circuits can be used up to 100MHz for xtal configurations. Butler oscillators are recommended for xtal configurations up to 150MHz.

The output impedance of the mixer is a 1.5k Ω resistor permitting direct connection to a 455kHz ceramic filter. The input resistance of the limiting IF amplifiers is also 1.5k Ω . With most 455kHz ceramic filters and many crystal filters, no impedance matching network is necessary. The IF amplifier has 43dB of gain and 5.5MHz bandwidth. The IF limiter has 60dB of gain and 4.5MHz bandwidth. To achieve optimum linearity of the log signal strength indicator, there must be a 12dB(v) insertion loss between the first and second IF stages. If the IF filter or interstage network does not cause

12dB(v) insertion loss, a fixed or variable resistor or an L pad for simultaneous loss and impedance matching can be added between the first IF output (Pin 16) and the interstage network. The overall gain will then be 90dB with 2MHz bandwidth.

The signal from the second limiting amplifier goes to a Gilbert cell quadrature detector. One port of the Gilbert cell is internally driven by the IF. The other output of the IF is AC-coupled to a tuned quadrature network. This signal, which now has a 90° phase relationship to the internal signal, drives the other port of the multiplier cell.

The demodulated output of the quadrature drives an internal op amp. This op amp can be configured as a unity gain buffer, or for simultaneous gain, filtering, and 2nd-order temperature compensation if needed. It can drive an AC load as low as 5k Ω with a rail-to-rail output.

A log signal strength completes the circuitry. The output range is greater than 90dB and is temperature compensated. This log signal strength indicator exceeds the criteria for AMPs or TACs cellular telephone. This signal drives an internal op amp. The op amp is capable of rail-to-rail output. It can be used for gain, filtering, or 2nd-order temperature compensation of the RSSI, if needed.

NOTE: $dB(v) = 20\log V_{OUT}/V_{IN}$

Low-voltage high performance mixer FM IF system

SA616

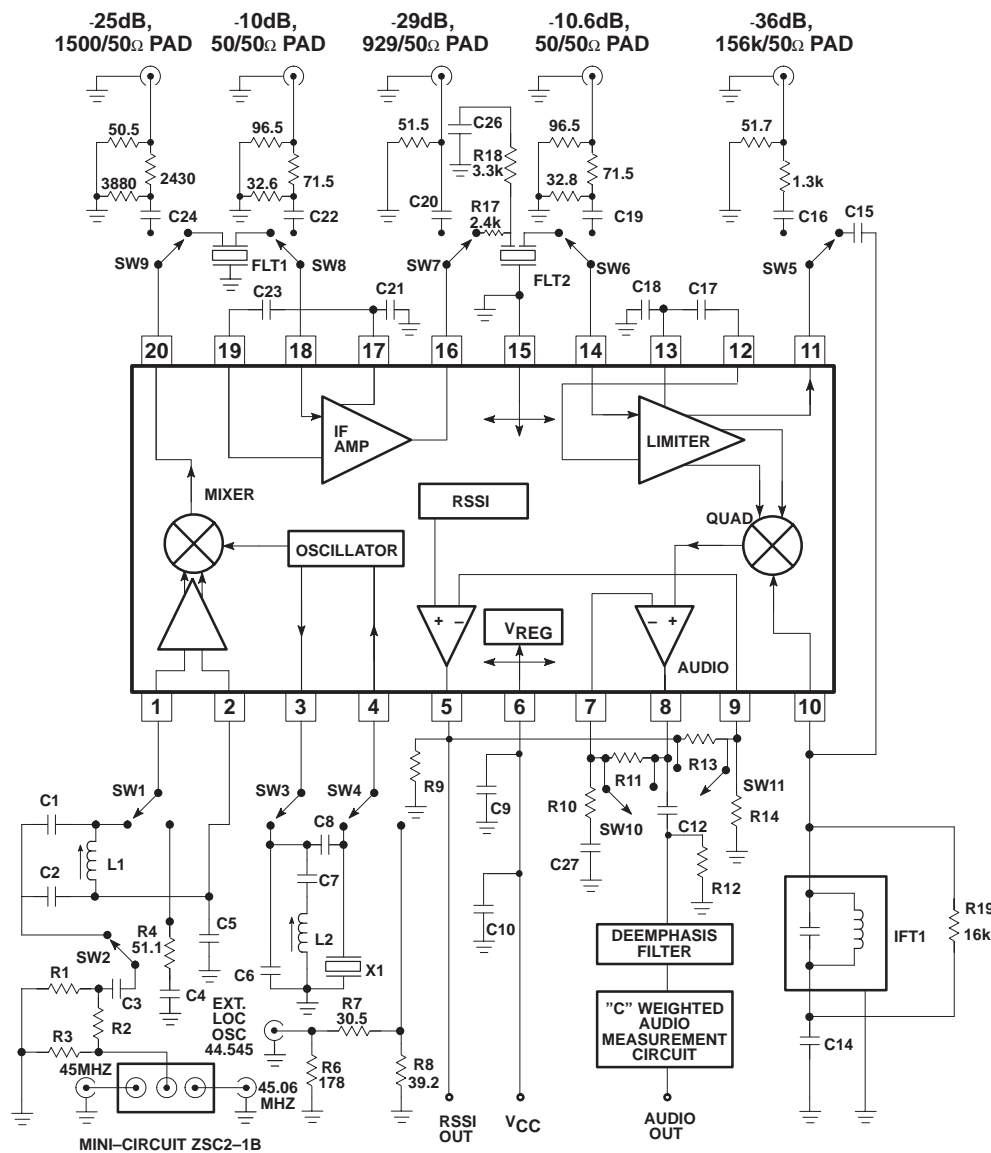

Automatic Test Circuit Component List

- | | | | |
|-----|-------------------------------|-------|---|
| C1 | 100pF NPO Ceramic | C27 | 100nF ±10% Monolithic Ceramic |
| C2 | 390pF NPO Ceramic | Flt 1 | Ceramic Filter Murata SFG455A3 or equiv |
| C5 | 100nF ±10% Monolithic Ceramic | Flt 2 | Ceramic Filter Murata SFG455A3 or equiv |
| C6 | 22pF NPO Ceramic | IFT 1 | 455kHz (Ce = 180pF) Toko RMC-2A6597H |
| C7 | 1nF Ceramic | L1 | 147-160nH Coilcraft UNI-10/142-04J08S |
| C8 | 10.0pF NPO Ceramic | L2 | 0.8µH nominal
Toko 292CNS-T1038Z |
| C9 | 100nF ±10% Monolithic Ceramic | X1 | 44.545MHz Crystal ICM4712701 |
| C10 | 15µF Tantalum (minimum) | R9 | 2kΩ ±1% 1/4W Metal Film |
| C12 | 2.2µF | R10 | 8.2kΩ ±1% |
| C14 | 100nF ±10% Monolithic Ceramic | R11 | 10kΩ ±1% |
| C15 | 10pF NPO Ceramic | R12 | 2kΩ ±1% |
| C17 | 100nF ±10% Monolithic Ceramic | R13 | 20kΩ ±1% |
| C18 | 100nF ±10% Monolithic Ceramic | R14 | 10kΩ ±1% |
| C21 | 100nF ±10% Monolithic Ceramic | R17 | 2.4kΩ ±5% 1/4W Carbon Composition |
| C23 | 100nF ±10% Monolithic Ceramic | R18 | 3.3kΩ |
| C25 | 100nF ±10% Monolithic Ceramic | R19 | 16kΩ |
| C26 | 100nF ±10% Monolithic Ceramic | | |

SR00369

Figure 3. SA616 45MHz Test Circuit (Relays as shown)

Low-voltage high performance mixer FM IF system

SA616

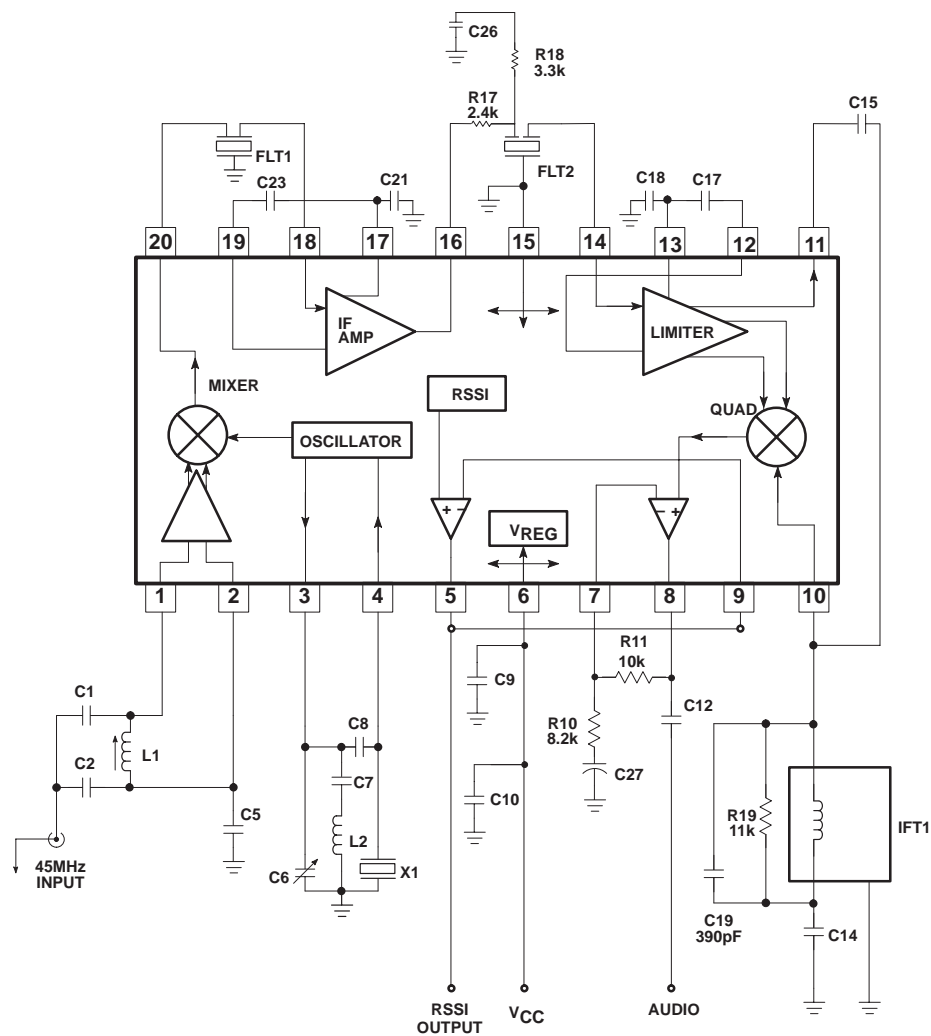

SA616 DK demoboard
Application Component List

- | | | | |
|-----|-------------------------------|-------|--|
| C1 | 51pF NPO Ceramic | C23 | 100nF ±10% Monolithic Ceramic |
| C2 | 220pF NPO Ceramic | C26 | 100nF ±10% Monolithic Ceramic |
| C5 | 100nF ±10% Monolithic Ceramic | C27 | 2.2µF Tantalum |
| C6 | 30pF trim cap | Flt 1 | Ceramic Filter Murata SFG455A3 or equiv |
| C7 | 1nF Ceramic | Flt 2 | Ceramic Filter Murata SFG455A3 or equiv |
| C8 | 10.0pF NPO Ceramic | IFT 1 | 330µH TOKO 303LN-1130 |
| C9 | 100nF ±10% Monolithic Ceramic | L1 | .33µH TOKO SCB-1320Z |
| C10 | 15µF Tantalum (minimum) | L2 | 1.2µH |
| C12 | 2.2µF ±10% Tantalum | X1 | 44.545MHz Crystal ICM4712701 |
| C14 | 100nF ±10% Monolithic Ceramic | R5 | Not Used in Application Board (see Note 8, pg 8) |
| C15 | 10pF NPO Ceramic | R10 | 8.2k ±5% 1/4W Carbon Composition |
| C17 | 100nF ±10% Monolithic Ceramic | R11 | 10k ±5% 1/4W Carbon Composition |
| C18 | 100nF ±10% Monolithic Ceramic | R17 | 2.4k ±5% 1/4W Carbon Composition |
| C19 | 390pF ±10% Monolithic Ceramic | R18 | 3.3k ±5% 1/4W Carbon Composition |
| C21 | 100nF ±10% Monolithic Ceramic | R19 | 11k ±5% 1/4W Carbon Composition |

SR00370

Figure 4. SA616 45MHz Application Circuit

Low-voltage high performance mixer FM IF system

SA616

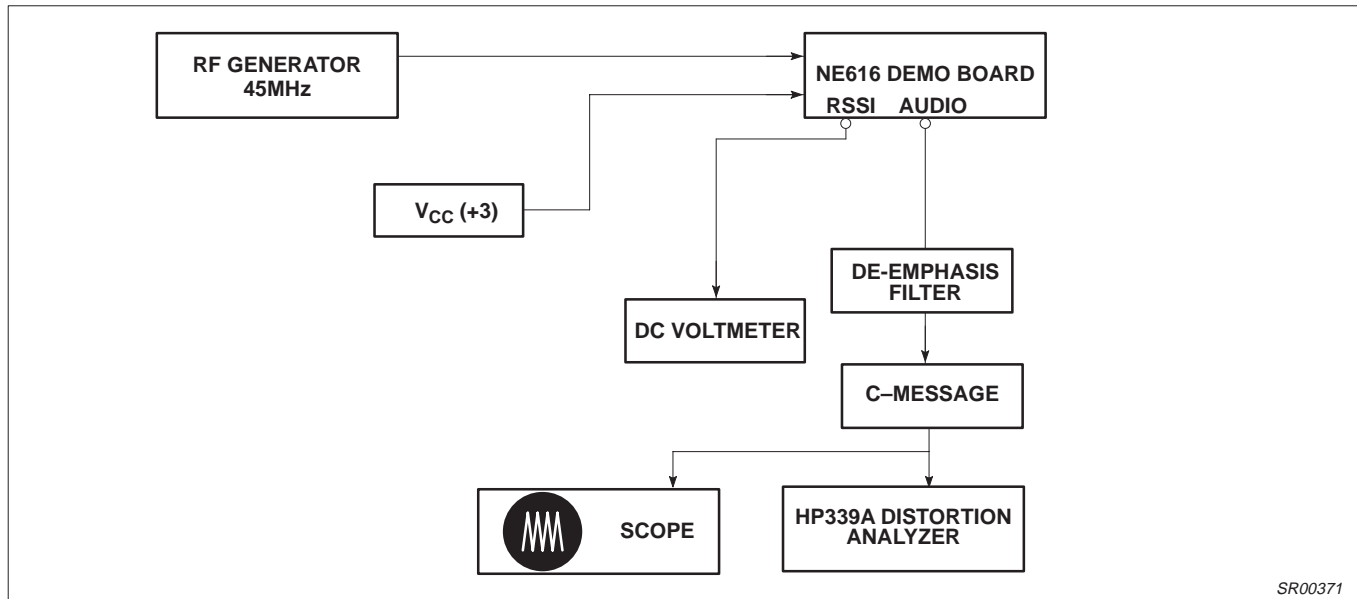

Figure 5. SA616 Application Circuit Test Set Up

NOTES:

1. C-message: The C-message and de-emphasis filter combination has a peak gain of 10 for accurate measurements. Without the gain, the measurements may be affected by the noise of the scope and HP339 analyzer. The de-emphasis filter has a fixed -6dB/Octave slope between 300Hz and 3kHz.
2. Ceramic filters: The ceramic filters can be 30kHz SFG455A3s made by Murata which have 30kHz IF bandwidth (they come in blue), or 16kHz CFU455Ds, also made by Murata (they come in black). All of our specifications and testing are done with the more wideband filter.
3. RF generator: Set your RF generator at 45.000MHz, use a 1kHz modulation frequency and a 6kHz deviation if you use 16kHz filters, or 8kHz if you use 30kHz filters.
4. Sensitivity: The measured typical sensitivity for 12dB SINAD should be 0.35 μ V or -116dBm at the RF input.
5. Layout: The layout is very critical in the performance of the receiver. We highly recommend our demo board layout.
6. RSSI: The smallest RSSI voltage (i.e., when no RF input is present and the input is terminated) is a measure of the quality of the layout and design. If the lowest RSSI voltage is 500mV or higher, it means the receiver is in regenerative mode. In that case, the receiver sensitivity will be worse than expected.
7. Supply bypass and shielding: All of the inductors, the quad tank, and their shield must be grounded. A 10-15 μ F or higher value tantalum capacitor on the supply line is essential. A low frequency ESR screening test on this capacitor will ensure consistent good sensitivity in production. A 0.1 μ F bypass capacitor on the supply pin, and grounded near the 44.545MHz oscillator improves sensitivity by 2-3dB.
8. R5 can be used to bias the oscillator transistor at a higher current for operation above 45MHz. Recommended value is 22k Ω , but should not be below 10k Ω .

Low-voltage high performance mixer FM IF system

SA616

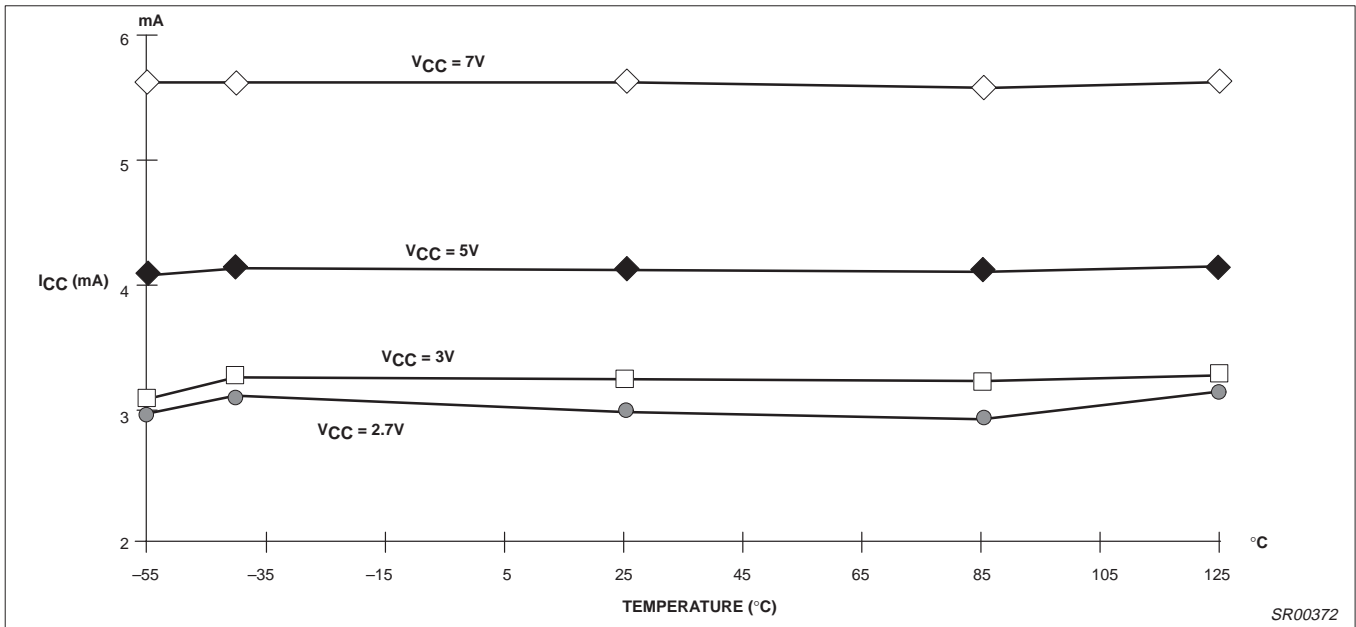

Figure 6. I_{CC} vs Temperature

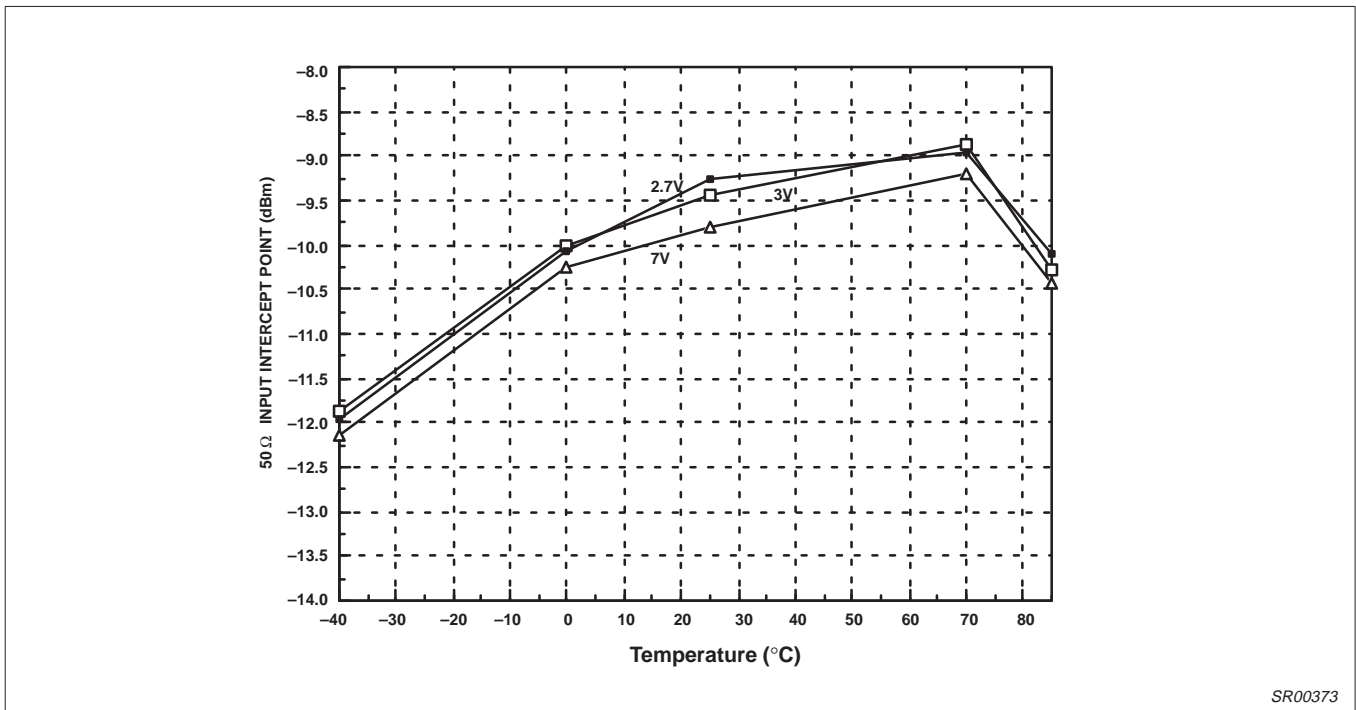
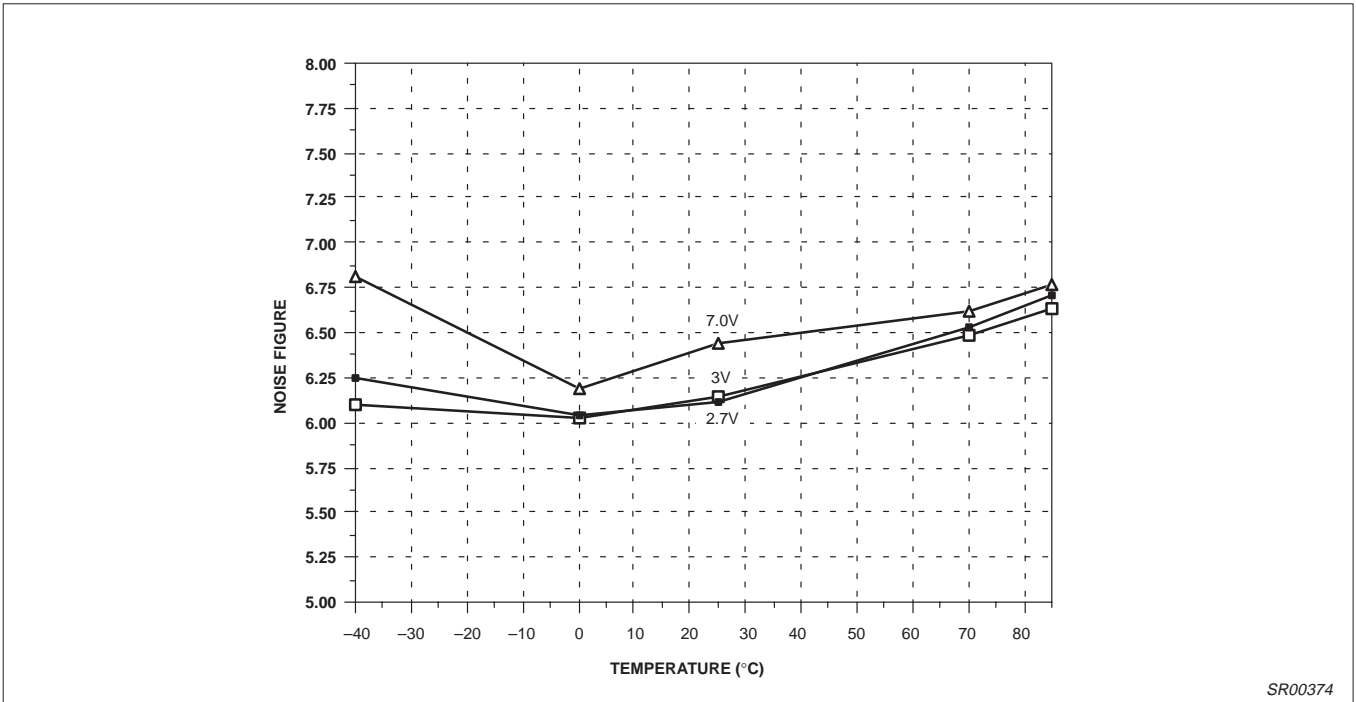

Figure 7. Third Order Intercept Point vs Supply Voltage

Low-voltage high performance mixer FM IF system

SA616



SR00374

Figure 8. Mixer Noise Figure vs Supply Voltage

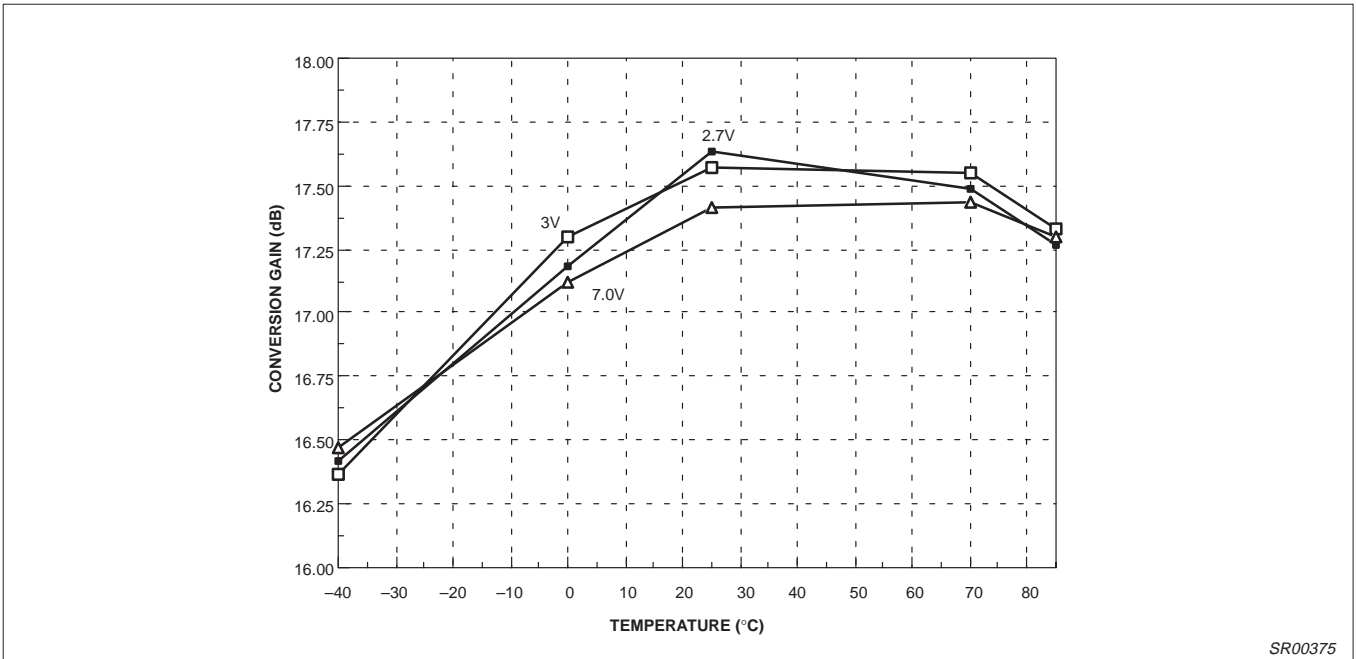

SR00375

Figure 9. Conversion Gain vs Supply Voltage

Low-voltage high performance mixer FM IF system

SA616

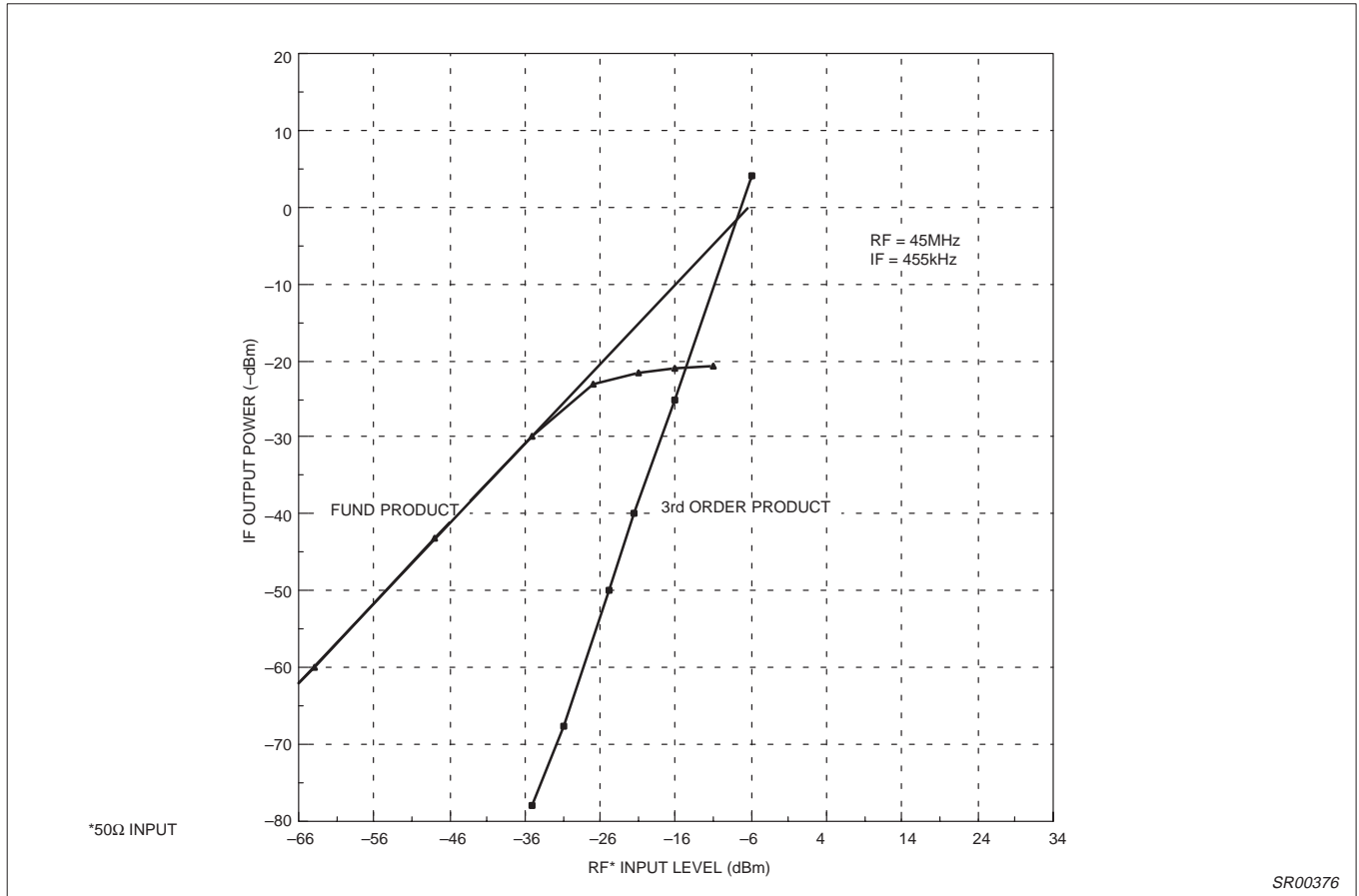

Figure 10. Mixer Third Order Intercept and Compression

SR00376

Low-voltage high performance mixer FM IF system

SA616

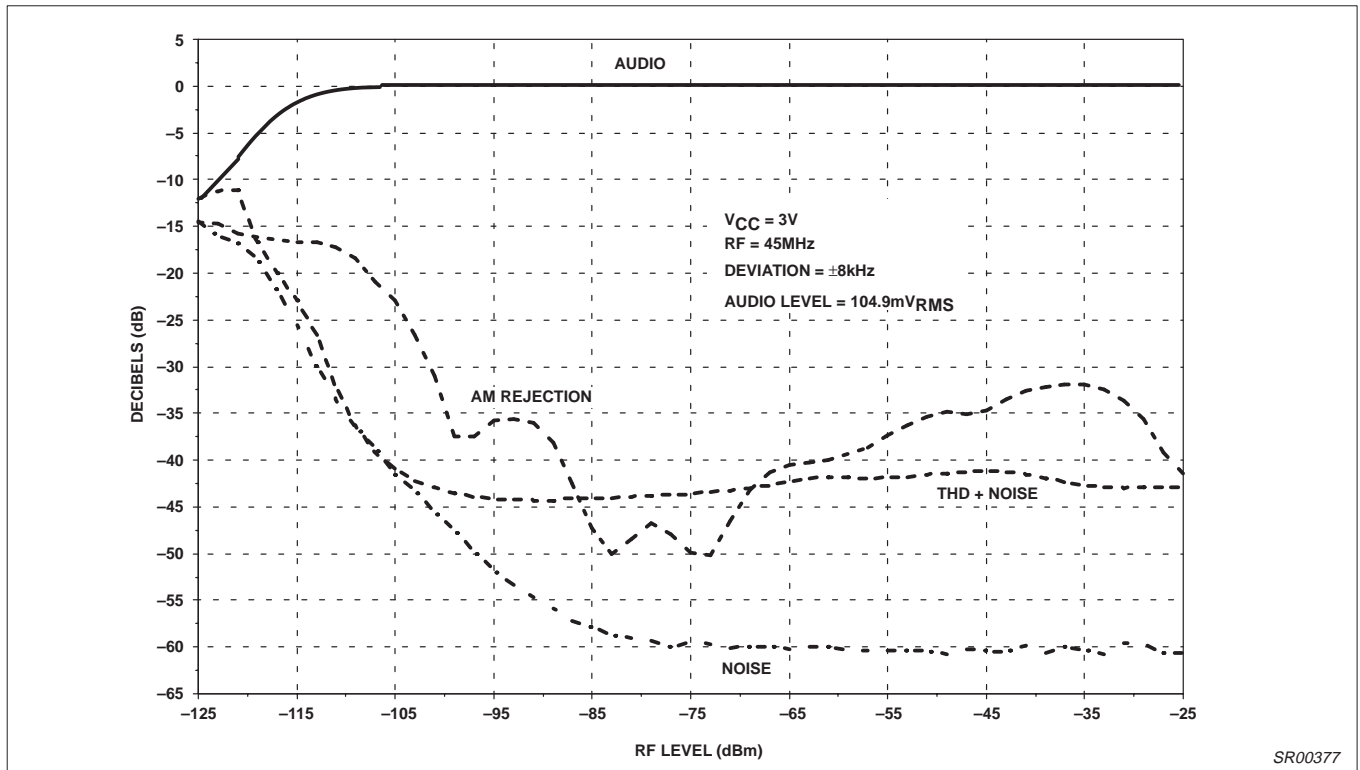

Figure 11. Sensitivity vs RF Level (-40°C)

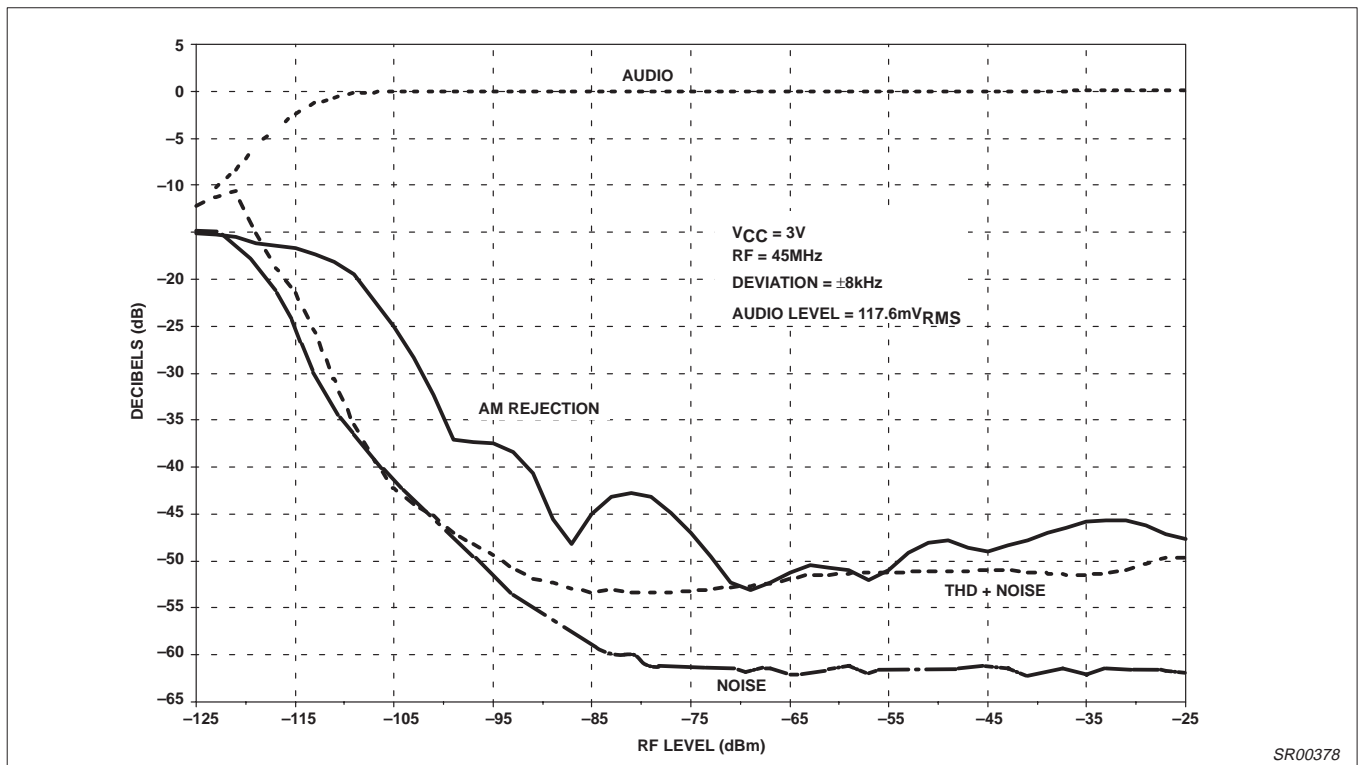

Figure 12. Sensitivity vs RF Level (+25°C)

Low-voltage high performance mixer FM IF system

SA616

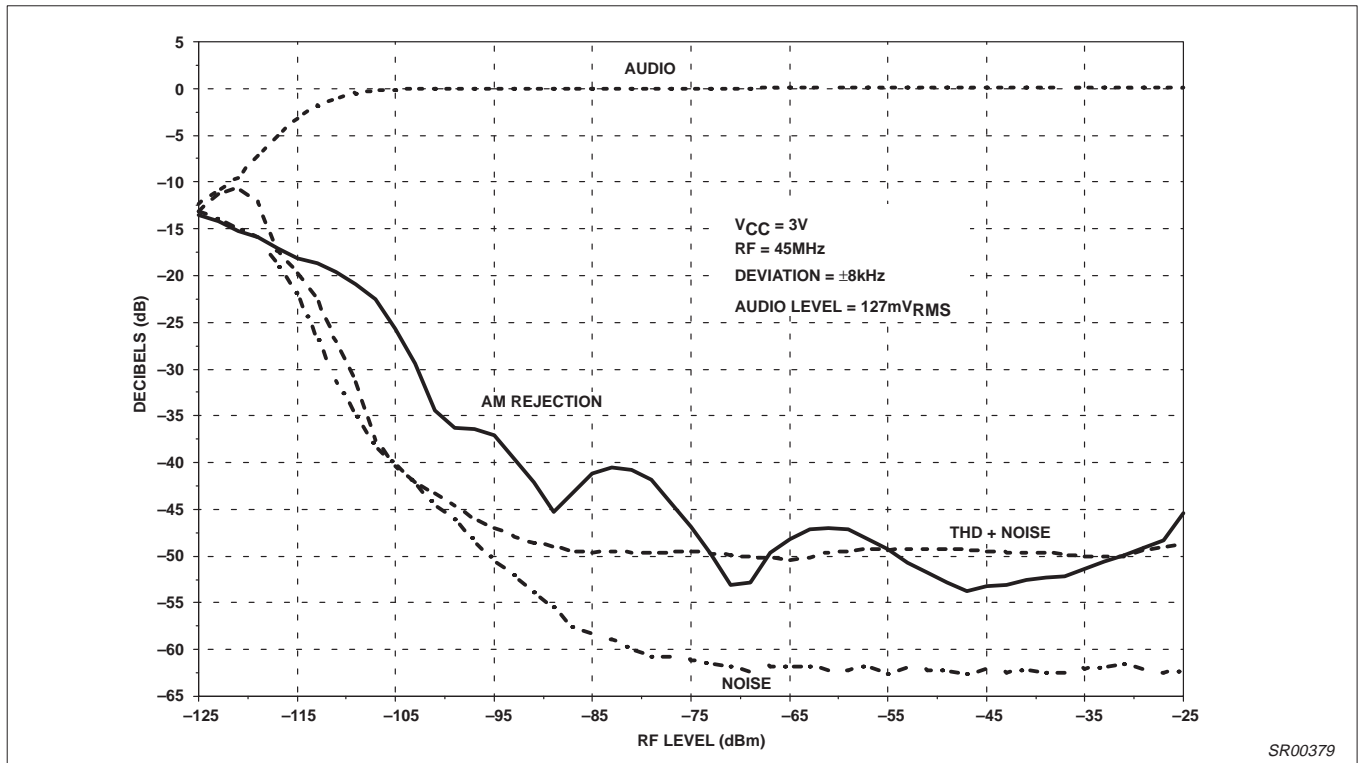

Figure 13. Sensitivity vs RF Level (Temperature 85°C)

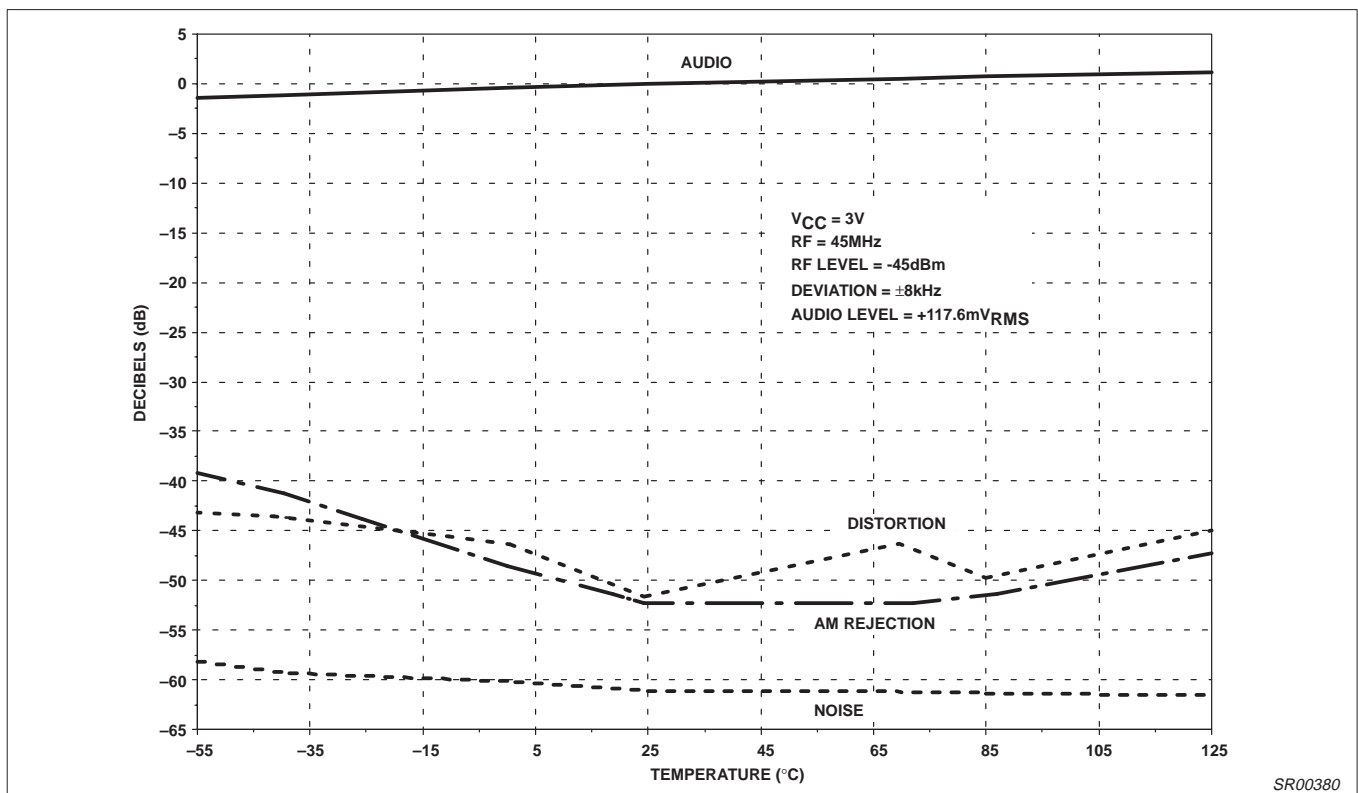

Figure 14. Relative Audio Level, Distortion, AM Rejection and Noise vs Temperature

Low-voltage high performance mixer FM IF system

SA616

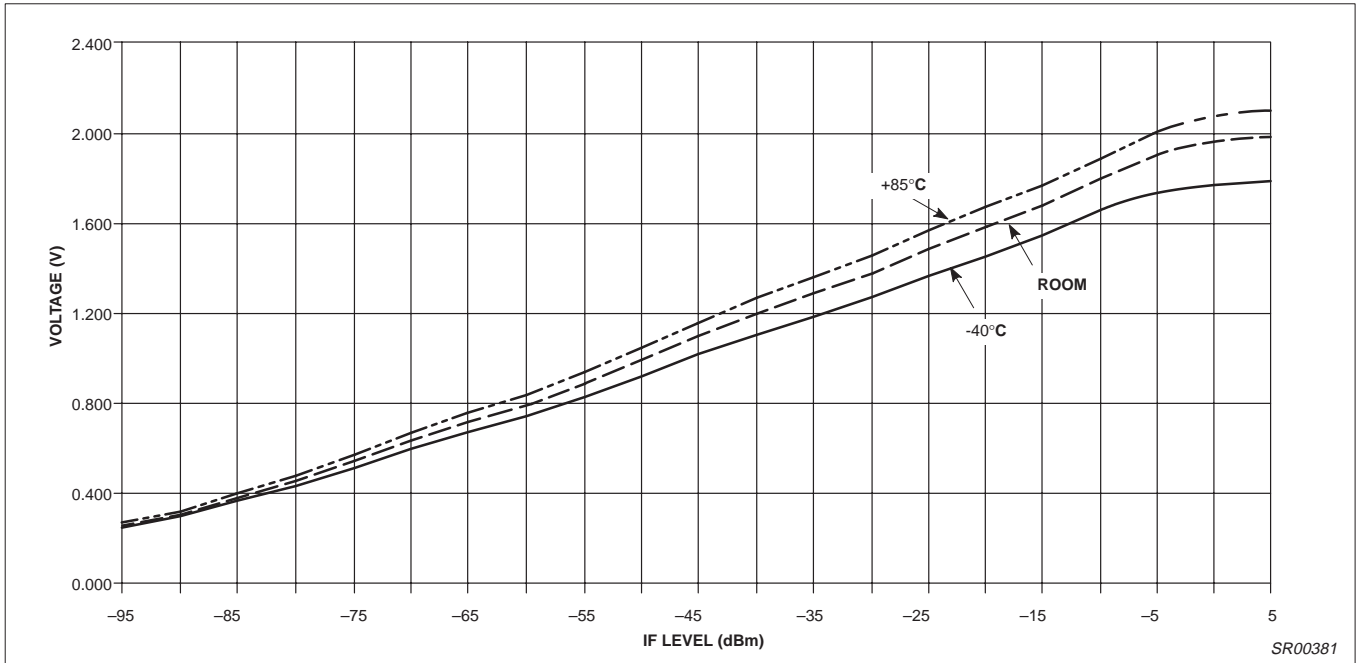

Figure 15. RSSI (455kHz IF @ 3V)

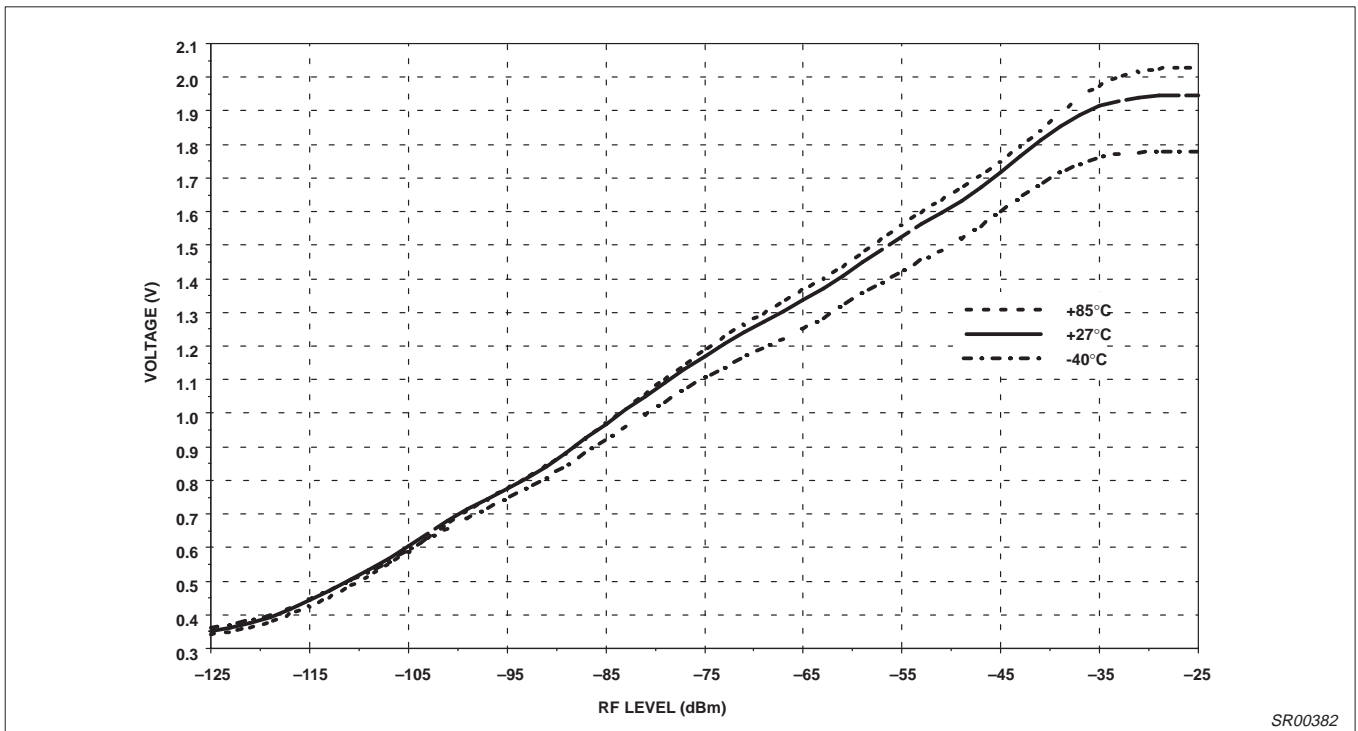

Figure 16. RSSI vs RF Level and Temperature - $V_{CC} = 3V$

Low-voltage high performance mixer FM IF system

SA616

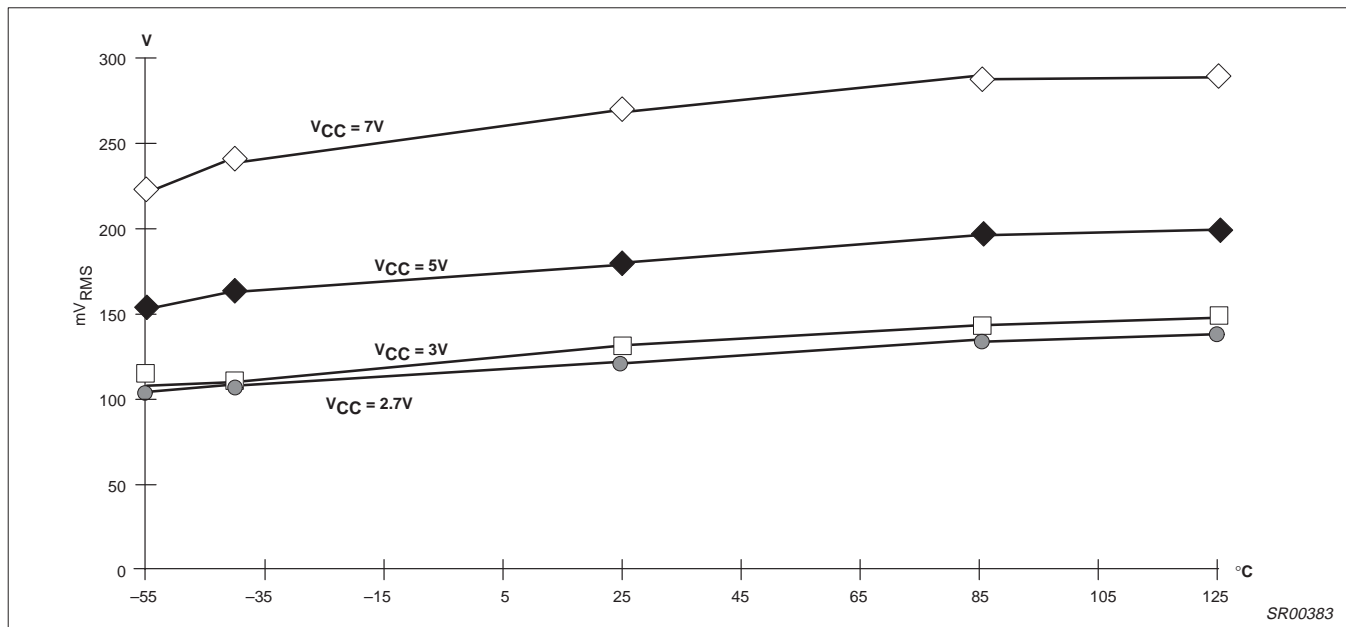
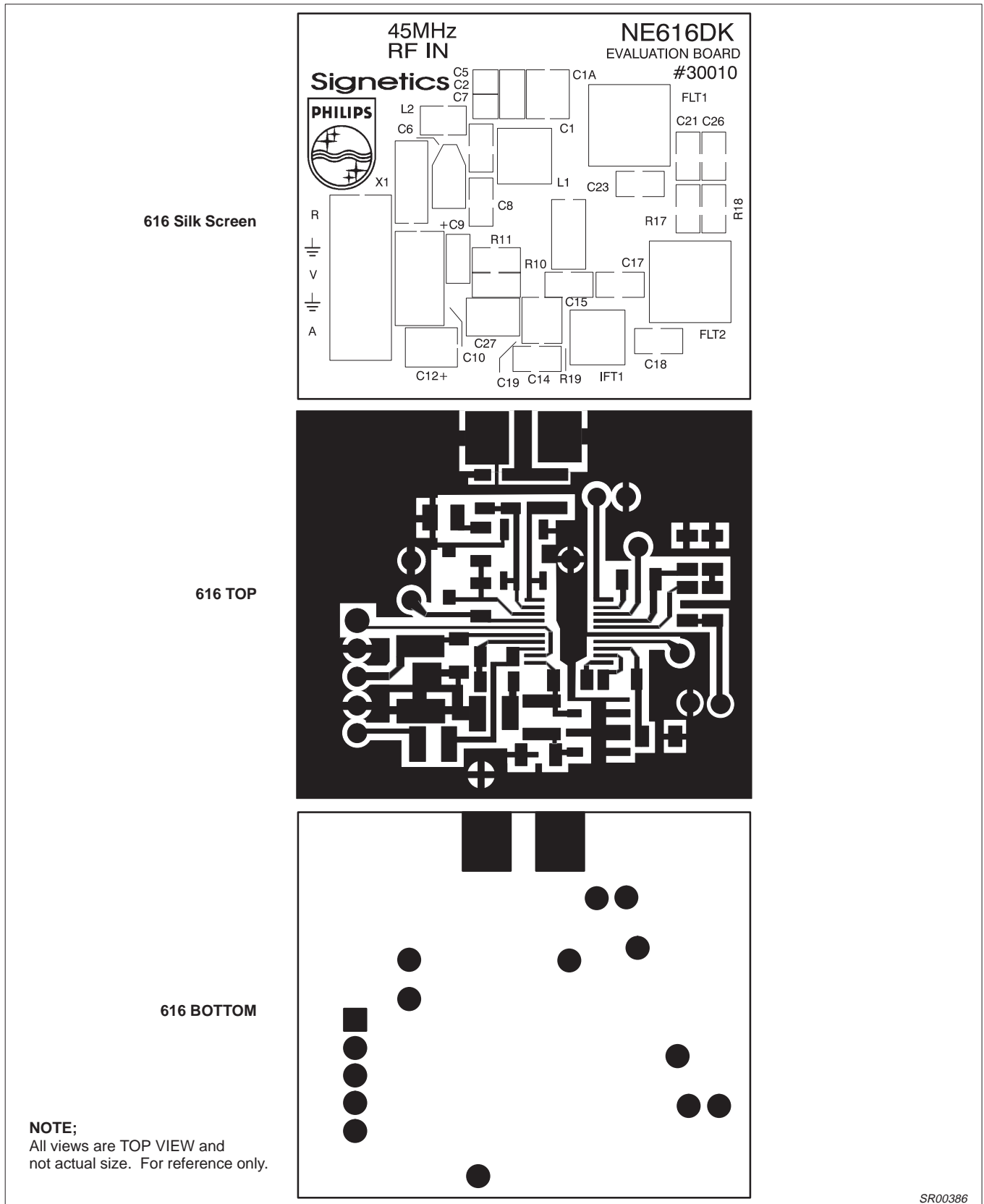

Figure 17. Audio Output vs Temperature

Low-voltage high performance mixer FM IF system

SA616



SR00386

Figure 18.

Low-voltage high performance mixer FM IF system

SA616

SSOP20: plastic shrink small outline package; 20 leads; body width 4.4 mm

SOT266-1

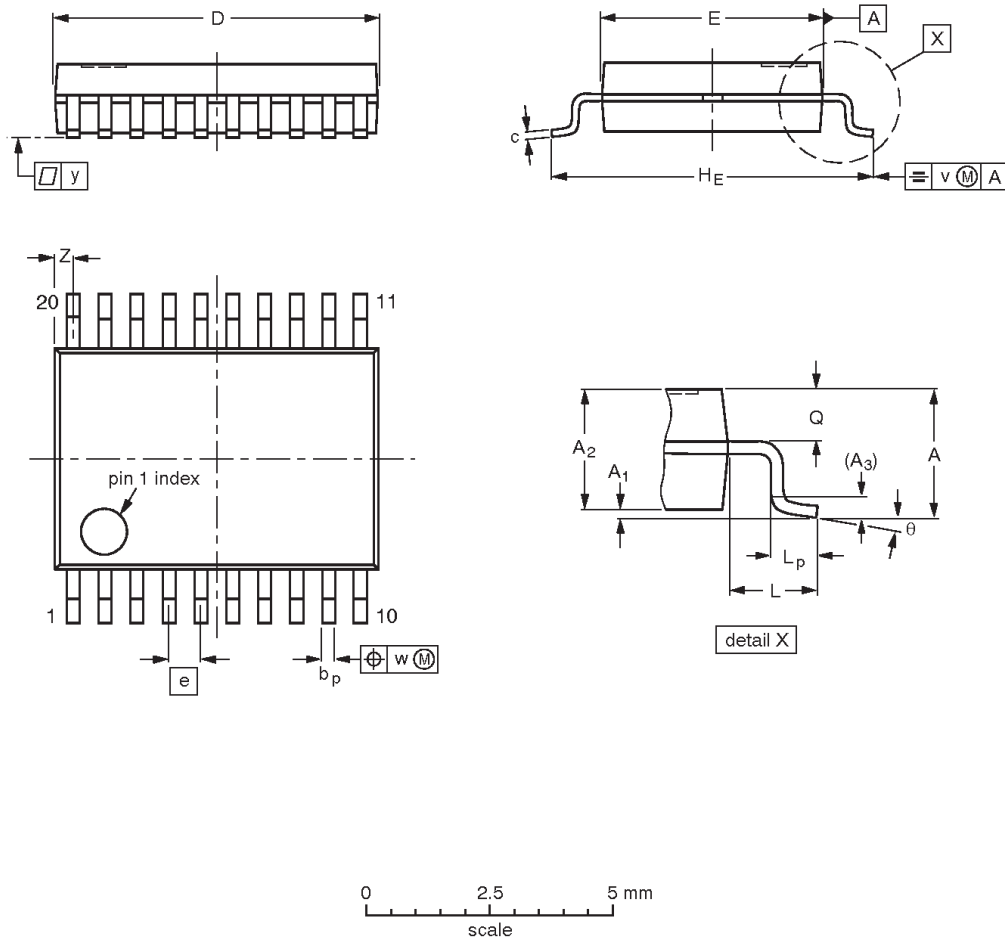

DIMENSIONS (mm are the original dimensions)

UNIT	A max.	A ₁	A ₂	A ₃	b _p	c	D ⁽¹⁾	E ⁽¹⁾	e	H _E	L	L _p	Q	v	w	y	Z ⁽¹⁾	θ
mm	1.5	0.15 0	1.4 1.2	0.25	0.32 0.20	0.20 0.13	6.6 6.4	4.5 4.3	0.65	6.6 6.2	1.0	0.75 0.45	0.65 0.45	0.2	0.13	0.1	0.48 0.18	10° 0°

Note

1. Plastic or metal protrusions of 0.20 mm maximum per side are not included.

OUTLINE VERSION	REFERENCES				EUROPEAN PROJECTION	ISSUE DATE
	IEC	JEDEC	EIAJ			
SOT266-1						90-04-05 95-02-25

Low-voltage high performance mixer FM IF system

SA616

DEFINITIONS

Data Sheet Identification	Product Status	Definition
<i>Objective Specification</i>	Formative or in Design	This data sheet contains the design target or goal specifications for product development. Specifications may change in any manner without notice.
<i>Preliminary Specification</i>	Preproduction Product	This data sheet contains preliminary data, and supplementary data will be published at a later date. Philips Semiconductors reserves the right to make changes at any time without notice in order to improve design and supply the best possible product.
<i>Product Specification</i>	Full Production	This data sheet contains Final Specifications. Philips Semiconductors reserves the right to make changes at any time without notice, in order to improve design and supply the best possible product.

Philips Semiconductors and Philips Electronics North America Corporation reserve the right to make changes, without notice, in the products, including circuits, standard cells, and/or software, described or contained herein in order to improve design and/or performance. Philips Semiconductors assumes no responsibility or liability for the use of any of these products, conveys no license or title under any patent, copyright, or mask work right to these products, and makes no representations or warranties that these products are free from patent, copyright, or mask work right infringement, unless otherwise specified. Applications that are described herein for any of these products are for illustrative purposes only. Philips Semiconductors makes no representation or warranty that such applications will be suitable for the specified use without further testing or modification.

LIFE SUPPORT APPLICATIONS

Philips Semiconductors and Philips Electronics North America Corporation Products are not designed for use in life support appliances, devices, or systems where malfunction of a Philips Semiconductors and Philips Electronics North America Corporation Product can reasonably be expected to result in a personal injury. Philips Semiconductors and Philips Electronics North America Corporation customers using or selling Philips Semiconductors and Philips Electronics North America Corporation Products for use in such applications do so at their own risk and agree to fully indemnify Philips Semiconductors and Philips Electronics North America Corporation for any damages resulting from such improper use or sale.

Philips Semiconductors
811 East Arques Avenue
P.O. Box 3409
Sunnyvale, California 94088-3409
Telephone 800-234-7381

© Copyright Philips Electronics North America Corporation 1997
 All rights reserved. Printed in U.S.A.

Let's make things better.