

Double-balanced mixer and oscillator

NE/SA612A

DESCRIPTION

The NE/SA612A is a low-power VHF monolithic double-balanced mixer with on-board oscillator and voltage regulator. It is intended for low cost, low power communication systems with signal frequencies to 500MHz and local oscillator frequencies as high as 200MHz. The mixer is a "Gilbert cell" multiplier configuration which provides gain of 14dB or more at 45MHz.

The oscillator can be configured for a crystal, a tuned tank operation, or as a buffer for an external L.O. Noise figure at 45MHz is typically below 6dB and makes the device well suited for high performance cordless phone/cellular radio. The low power consumption makes the NE/SA612A excellent for battery operated equipment. Networking and other communications products can benefit from very low radiated energy levels within systems. The NE/SA612A is available in an 8-lead dual in-line plastic package and an 8-lead SO (surface mounted miniature package).

FEATURES

- Low current consumption
- Low cost
- Operation to 500MHz
- Low radiated energy
- Low external parts count; suitable for crystal/ceramic filter
- Excellent sensitivity, gain, and noise figure

PIN CONFIGURATION

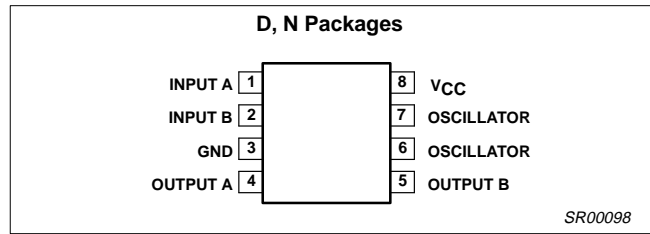

Figure 1. Pin Configuration

APPLICATIONS

- Cordless telephone
- Portable radio
- VHF transceivers
- RF data links
- Sonabuys
- Communications receivers
- Broadband LANs
- HF and VHF frequency conversion
- Cellular radio mixer/oscillator

ORDERING INFORMATION

| DESCRIPTION | TEMPERATURE RANGE | ORDER CODE | DWG # |
|--|-------------------|------------|---------|
| 8-Pin Plastic Dual In-Line Plastic (DIP) | 0 to +70°C | NE612AN | SOT97-1 |
| 8-Pin Plastic Small Outline (SO) package (Surface-Mount) | 0 to +70°C | NE612AD | SOT96-1 |
| 8-Pin Plastic Dual In-Line Plastic (DIP) | -40 to +85°C | SA612AN | SOT97-1 |
| 8-Pin Plastic Small Outline (SO) package (Surface-Mount) | -40 to +85°C | SA612AD | SOT96-1 |

BLOCK DIAGRAM

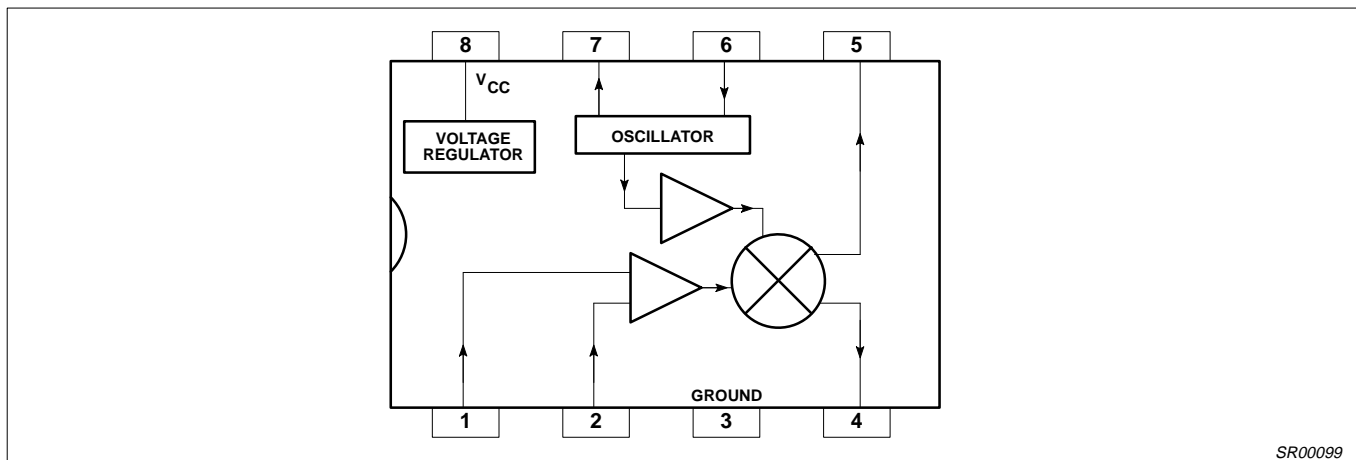

Figure 2. Block Diagram

Double-balanced mixer and oscillator

NE/SA612A

ABSOLUTE MAXIMUM RATINGS

| SYMBOL | PARAMETER | RATING | UNIT |
|------------------|---|------------------------|------|
| V _{CC} | Maximum operating voltage | 9 | V |
| T _{STG} | Storage temperature | -65 to +150 | °C |
| T _A | Operating ambient temperature range NE SA | 0 to +70 -40 to +85 | °C |

AC/DC ELECTRICAL CHARACTERISTICST_A=25°C, V_{CC} = 6V, Figure 3

| SYMBOL | PARAMETER | TEST CONDITION | LIMITS | | | UNIT |
|------------------|--------------------------------------|--------------------------|--------|-----|-----|------|
| | | | Min | Typ | Max | |
| V _{CC} | Power supply voltage range | | 4.5 | | 8.0 | V |
| | DC current drain | | | 2.4 | 3.0 | mA |
| f _{IN} | Input signal frequency | | | 500 | | MHz |
| f _{OSC} | Oscillator frequency | | | 200 | | MHz |
| | Noise figured at 45MHz | | | 5.0 | | dB |
| | Third-order intercept point at 45MHz | RF _{IN} =-45dBm | | -13 | | dBm |
| | Conversion gain at 45MHz | | 14 | 17 | | dB |
| R _{IN} | RF input resistance | | 1.5 | | | kΩ |
| C _{IN} | RF input capacitance | | | 3 | | pF |
| | Mixer output resistance | (Pin 4 or 5) | | 1.5 | | kΩ |

DESCRIPTION OF OPERATION

The NE/SA612A is a Gilbert cell, an oscillator/buffer, and a temperature compensated bias network as shown in the equivalent circuit. The Gilbert cell is a differential amplifier (Pins 1 and 2) which drives a balanced switching cell. The differential input stage provides gain and determines the noise figure and signal handling performance of the system.

The NE/SA612A is designed for optimum low power performance. When used with the NE614A as a 45MHz cordless phone/cellular

radio 2nd IF and demodulator, the NE/SA612A is capable of receiving -119dBm signals with a 12dB S/N ratio. Third-order intercept is typically -15dBm (that's approximately +5dBm output intercept because of the RF gain). The system designer must be cognizant of this large signal limitation. When designing LANs or other closed systems where transmission levels are high, and small-signal or signal-to-noise issues not critical, the input to the NE/SA612A should be appropriately scaled.

Double-balanced mixer and oscillator

NE/SA612A

TEST CONFIGURATION

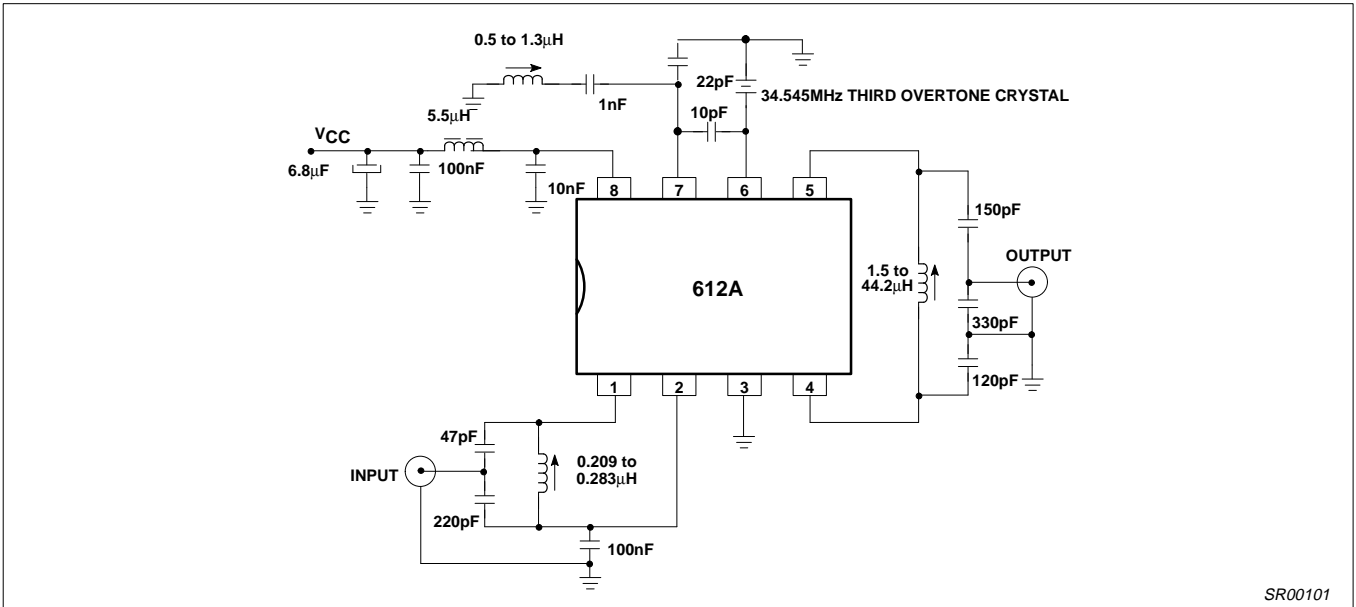

SR00101

Figure 3. Test Configuration

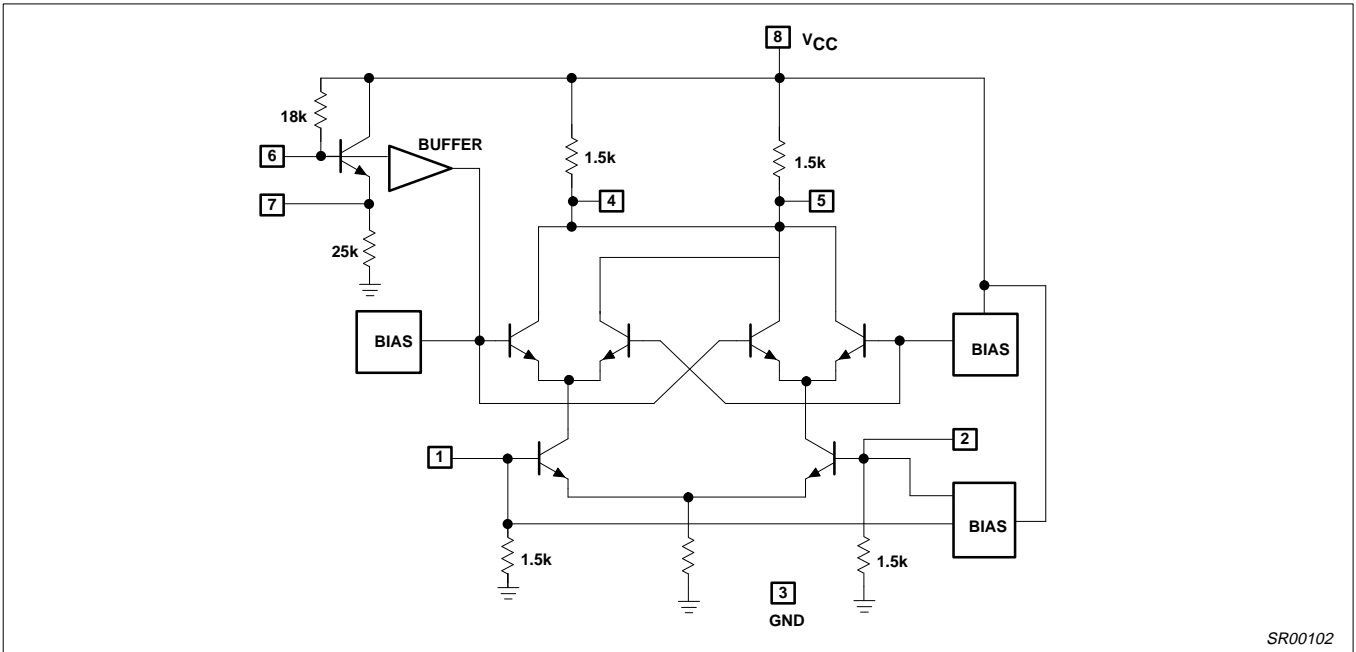

SR00102

Figure 4. Equivalent Circuit

Double-balanced mixer and oscillator

NE/SA612A

Besides excellent low power performance well into VHF, the NE/SA612A is designed to be flexible. The input, output, and oscillator ports can support a variety of configurations provided the designer understands certain constraints, which will be explained here.

The RF inputs (Pins 1 and 2) are biased internally. They are symmetrical. The equivalent AC input impedance is approximately $1.5k \parallel 3pF$ through 50MHz. Pins 1 and 2 can be used interchangeably, but they should not be DC biased externally. Figure 5 shows three typical input configurations.

The mixer outputs (Pins 4 and 5) are also internally biased. Each output is connected to the internal positive supply by a $1.5k\Omega$ resistor. This permits direct output termination yet allows for balanced output as well. Figure 6 shows three single-ended output configurations and a balanced output.

The oscillator is capable of sustaining oscillation beyond 200MHz in crystal or tuned tank configurations. The upper limit of operation is determined by tank "Q" and required drive levels. The higher the Q of the tank or the smaller the required drive, the higher the

permissible oscillation frequency. If the required L.O. is beyond oscillation limits, or the system calls for an external L.O., the external signal can be injected at Pin 6 through a DC blocking capacitor. External L.O. should be $200mV_{P-P}$ minimum to $300mV_{P-P}$ maximum.

Figure 7 shows several proven oscillator circuits. Figure 7a is appropriate for cordless phones/cellular radio. In this circuit a third overtone parallel-mode crystal with approximately 5pF load capacitance should be specified. Capacitor C3 and inductor L1 act as a fundamental trap. In fundamental mode oscillation the trap is omitted.

Figure 8 shows a Colpitts varacter tuned tank oscillator suitable for synthesizer-controlled applications. It is important to buffer the output of this circuit to assure that switching spikes from the first counter or prescaler do not end up in the oscillator spectrum. The dual-gate MOSFET provides optimum isolation with low current. The FET offers good isolation, simplicity, and low current, while the bipolar circuits provide the simple solution for non-critical applications. The resistive divider in the emitter-follower circuit should be chosen to provide the minimum input signal which will assume correct system operation.

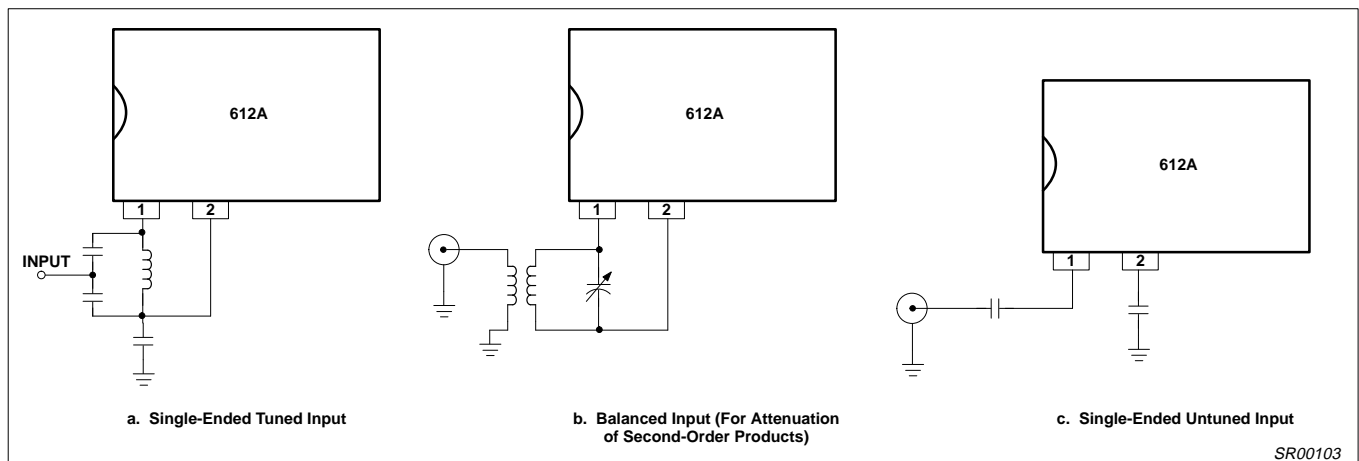

Figure 5. Input Configuration

Double-balanced mixer and oscillator

NE/SA612A

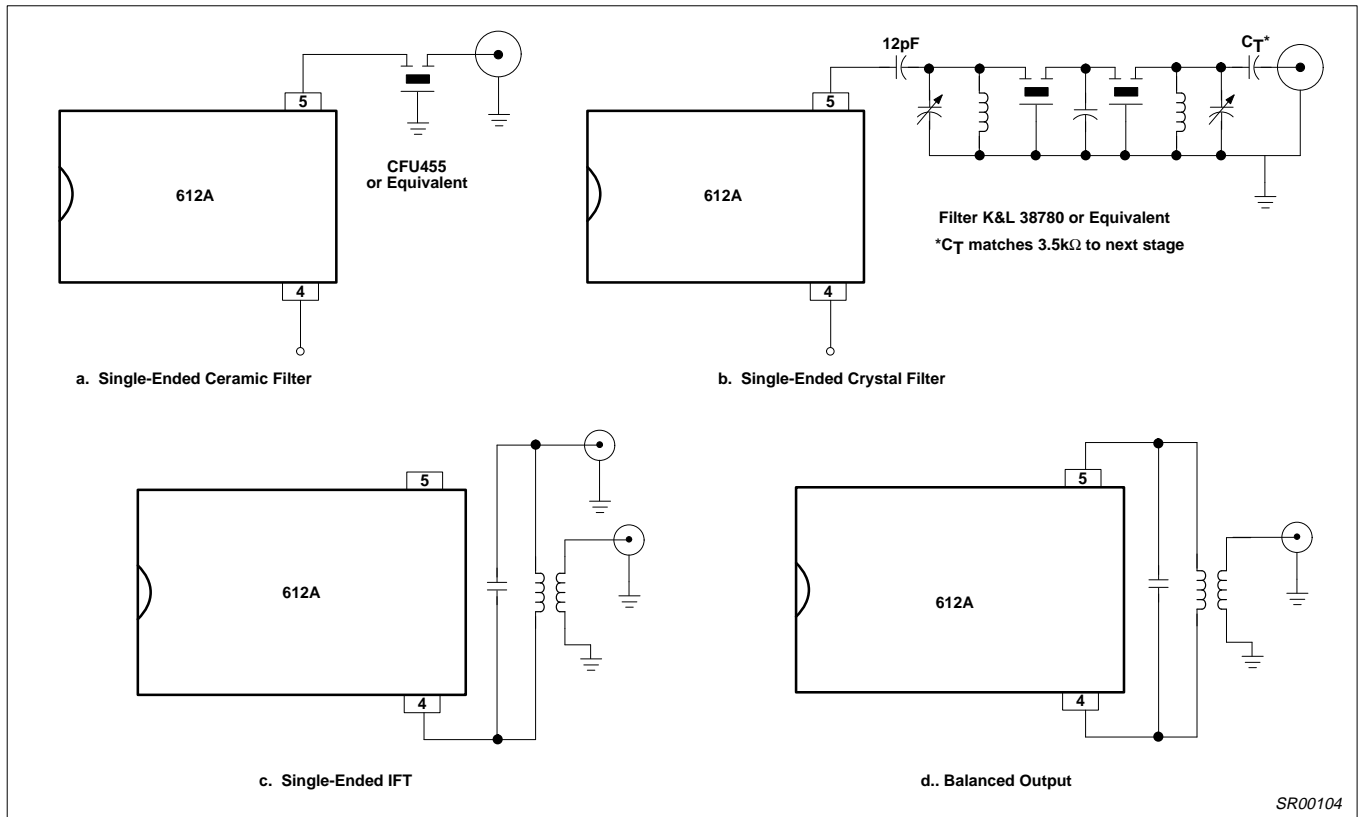

Figure 6. Output Configuration

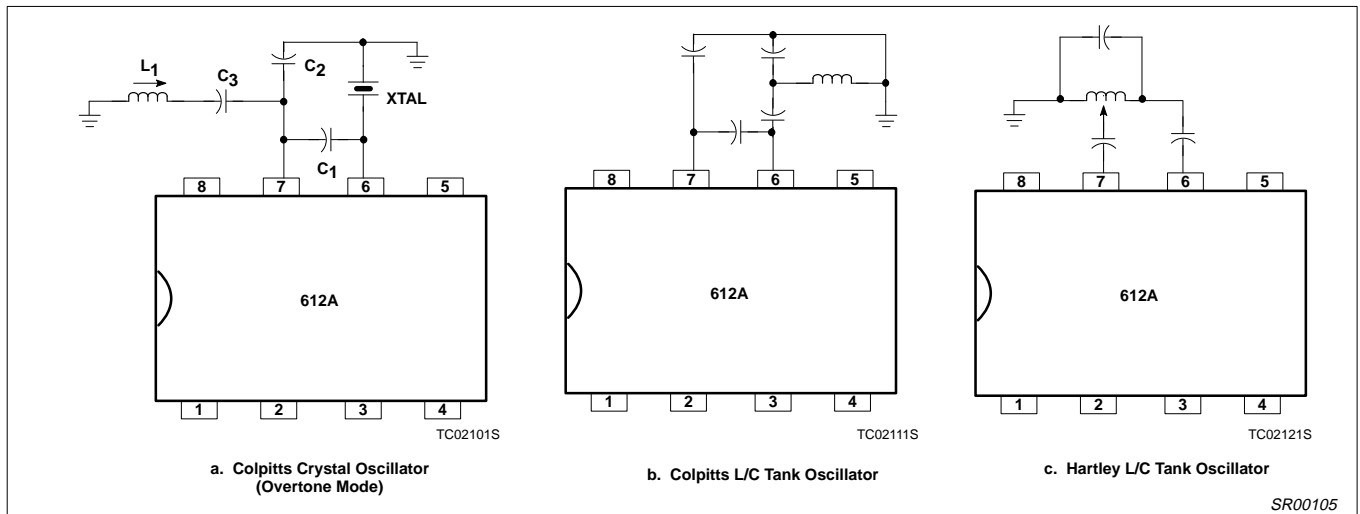
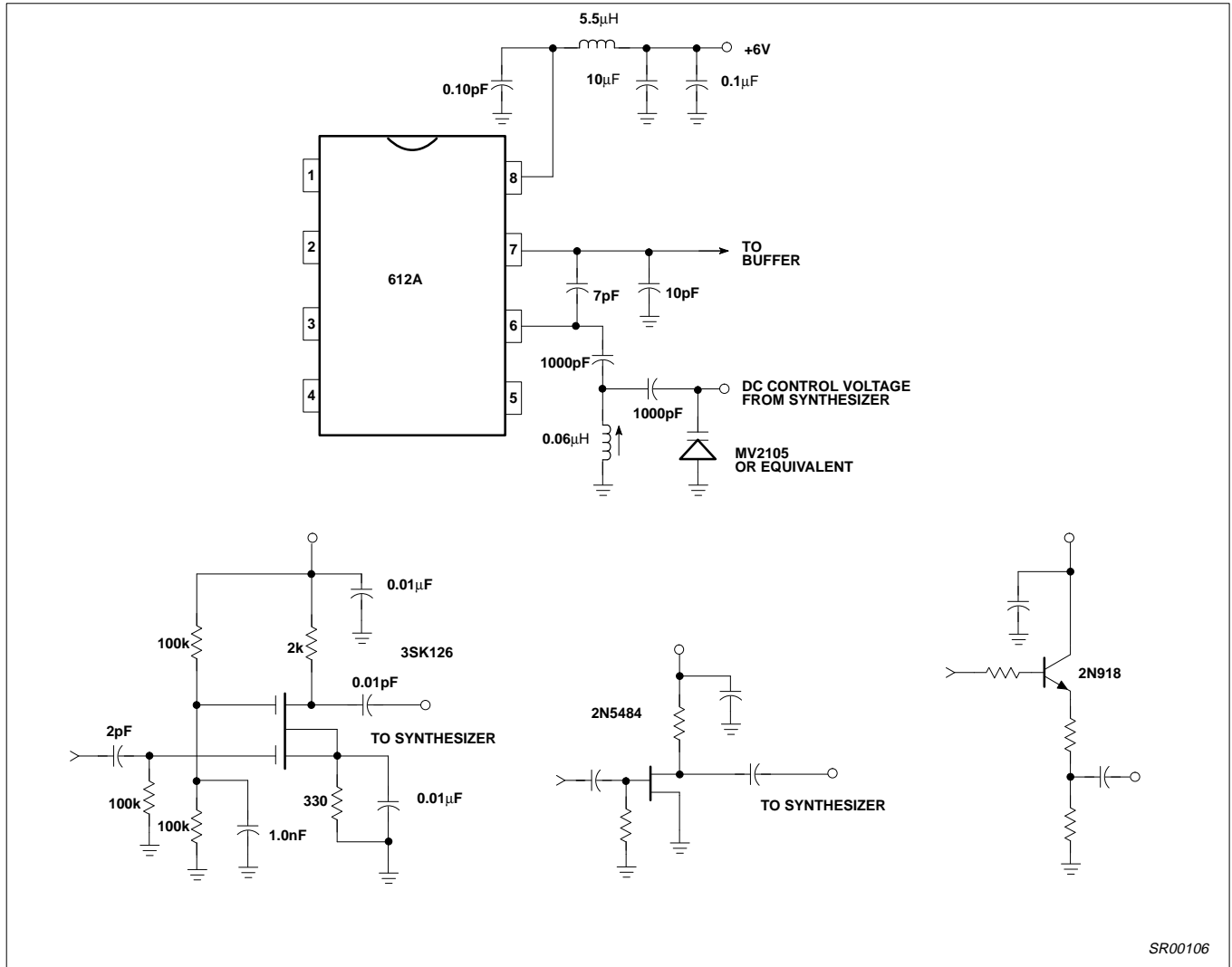

Figure 7. Oscillator Circuits

Double-balanced mixer and oscillator

NE/SA612A



SR00106

Figure 8. Colpitts Oscillator Suitable for Synthesizer Applications and Typical Buffers

Double-balanced mixer and oscillator

NE/SA612A

TEST CONFIGURATION

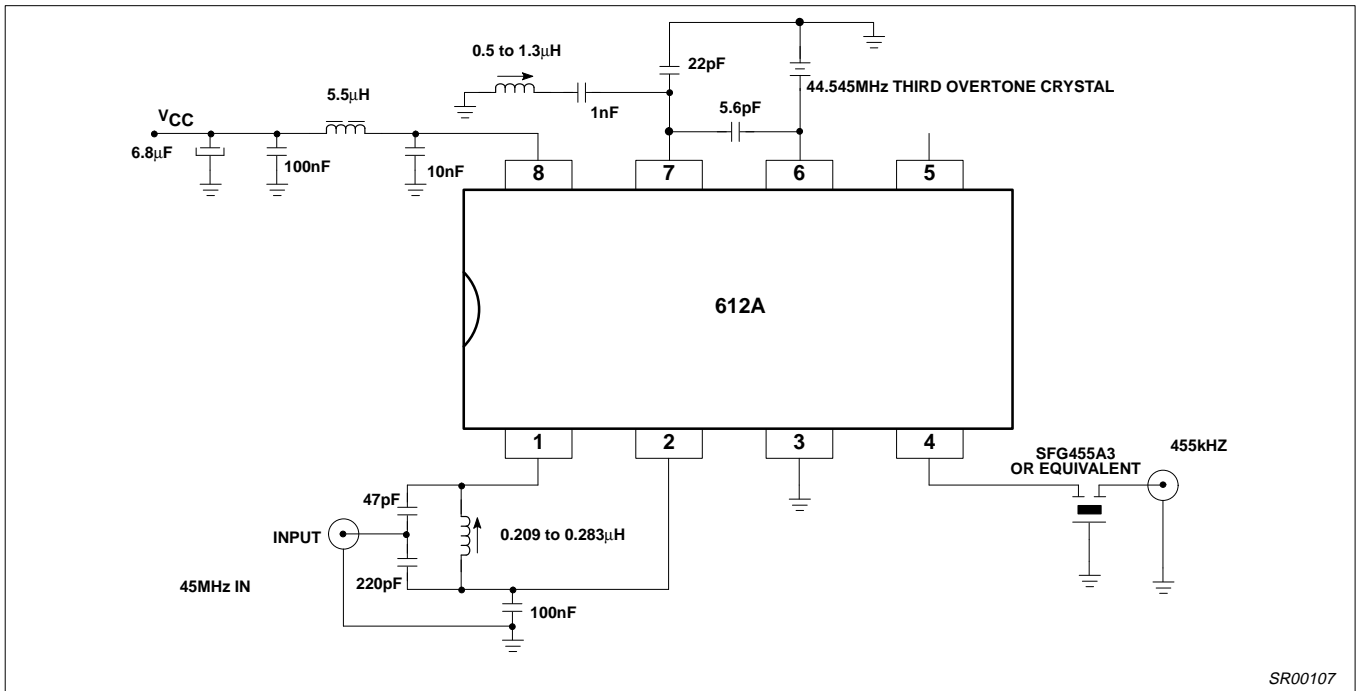

Figure 9. Typical Application for Cordless/Cellular Radio

Double-balanced mixer and oscillator

NE/SA612A

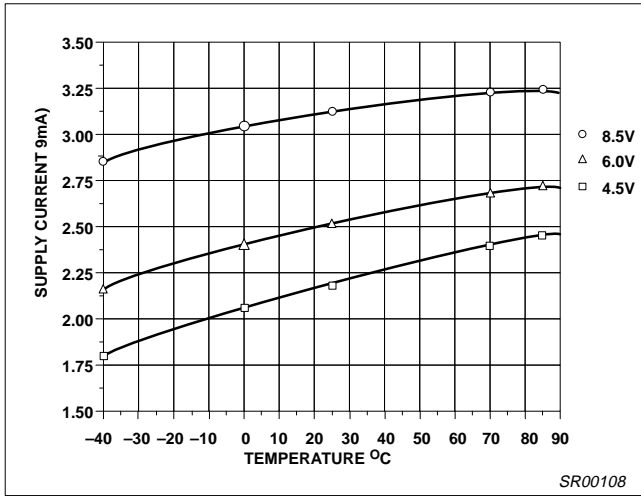

Figure 10. I_{CC} vs Supply Voltage

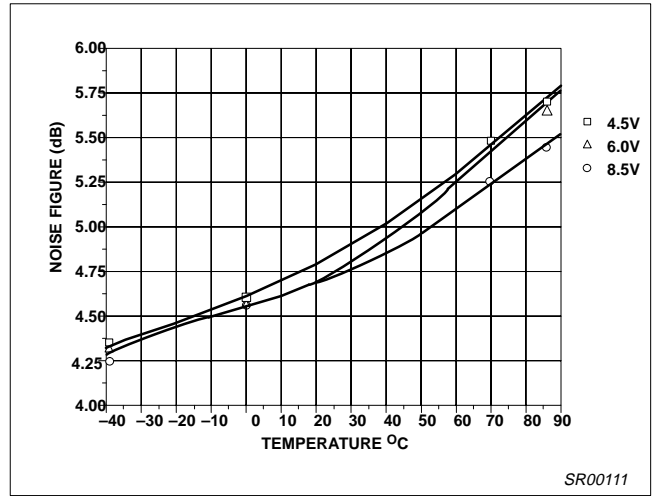

Figure 13. Noise Figure

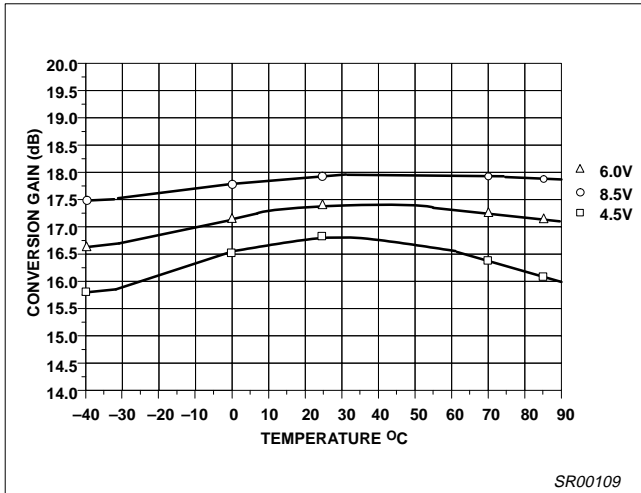

Figure 11. Conversion Gain vs Supply Voltage

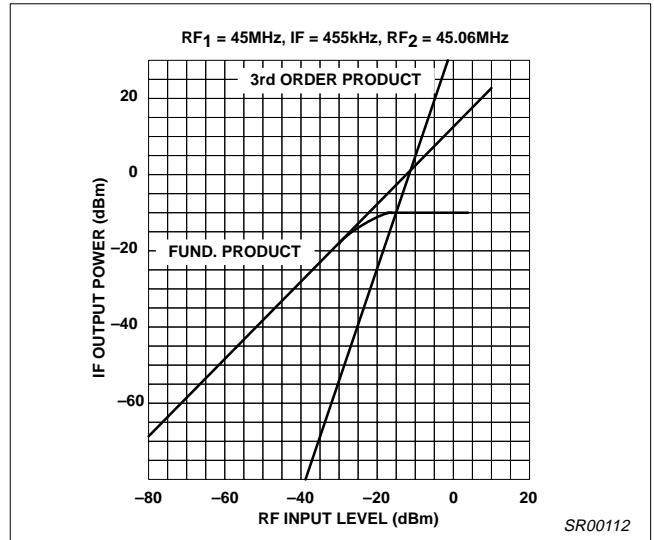

Figure 14. Third-Order Intercept and Compression

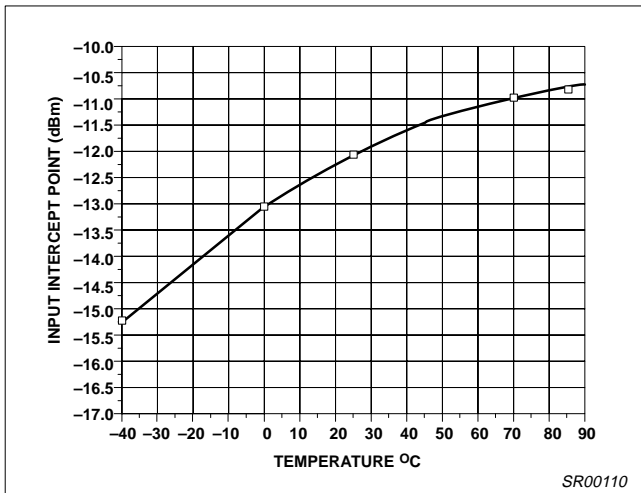

Figure 12. Third-Order Intercept Point

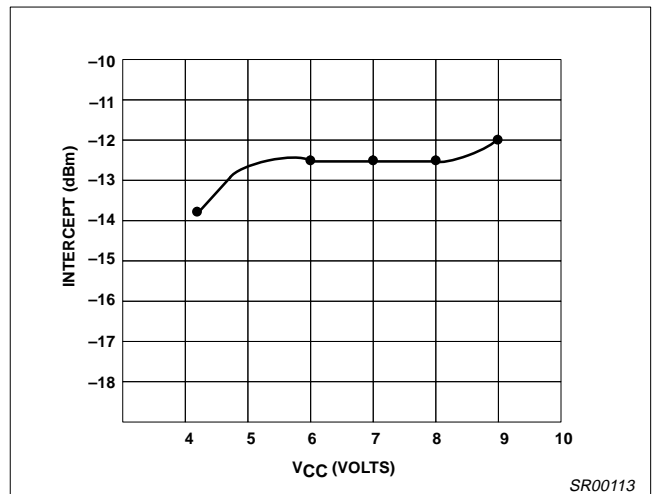

Figure 15. Input Third-Order Intermod Point vs V_{CC}