

64-Mb HYPERRAM™ self-refresh DRAM (PSRAM)

HYPERBUS™ interface, 1.8 V/3.0 V

Features

• Interface

- HYPERBUS™ interface
- 1.8 V / 3.0 V interface support
 - Single-ended clock (CK) - 11 bus signals
 - Optional differential clock (CK, CK#) - 12 bus signals
- Chip select (CS#)
- 8-bit data bus (DQ[7:0])
- Hardware reset (RESET#)
- Bidirectional read-write data strobe (RWDS)
 - Output at the start of all transactions to indicate refresh latency
 - Output during read transactions as Read data strobe
 - Input during write transactions as Write data mask
- Optional DDR center-aligned read strobe (DCARS)
 - During read transactions RWDS is offset by a second clock, phase shifted from CK
 - The Phase shifted clock is used to move the RWDS transition edge within the read data eye

• Performance, power, and packages

- 200 MHz maximum clock rate
- DDR - transfers data on both edges of the clock
- Data throughput up to 400 MBps (3,200 Mbps)
- Configurable burst characteristics:
 - Linear burst
- Wrapped burst lengths:
 - 16 bytes (8 clocks)
 - 32 bytes (16 clocks)
 - 64 bytes (32 clocks)
 - 128 bytes (64 clocks)
- Hybrid option - one wrapped burst followed by linear burst

• Configurable output drive strength

• Power modes

- Hybrid Sleep mode
- Deep power-down

• Array refresh

- Partial memory array(1/8, 1/4, 1/2, and so on)
- Full

• Package

- 24-ball FBGA

• Operating temperature range

- Industrial (I): -40 °C to +85 °C
- Industrial Plus (V): -40 °C to +105 °C
- Automotive, AEC-Q100 grade 3: -40 °C to +85 °C
- Automotive, AEC-Q100 grade 2: -40 °C to +105 °C

64-Mb HYPERRAM™ self-refresh DRAM (PSRAM)
HYPERBUS™ interface, 1.8 V/3.0 V



Performance summary

- **Technology**
 - 38-nm DRAM

Performance summary

Read transaction timings	Unit
Maximum clock rate at 1.8 V V_{CC}/V_{CCQ}	200 MHz
Maximum clock rate at 3.0 V V_{CC}/V_{CCQ}	200 MHz
Maximum access time (t_{ACC})	35 ns

Maximum current consumption	Unit
Burst read or write (linear burst at 200 MHz, 1.8 V)	25 mA
Burst read or write (linear burst at 200 MHz, 3.0 V)	30 mA
Standby ($CS\# = V_{CC} = 3.6 V, 105\text{ }^{\circ}C$)	360 μA
Deep power down ($CS\# = V_{CC} = 3.6 V, 105\text{ }^{\circ}C$)	15 μA
Standby ($CS\# = V_{CC} = 2.0 V, 105\text{ }^{\circ}C$)	330 μA
Deep power down ($CS\# = V_{CC} = 2.0 V, 105\text{ }^{\circ}C$)	12 μA

Logic block diagram

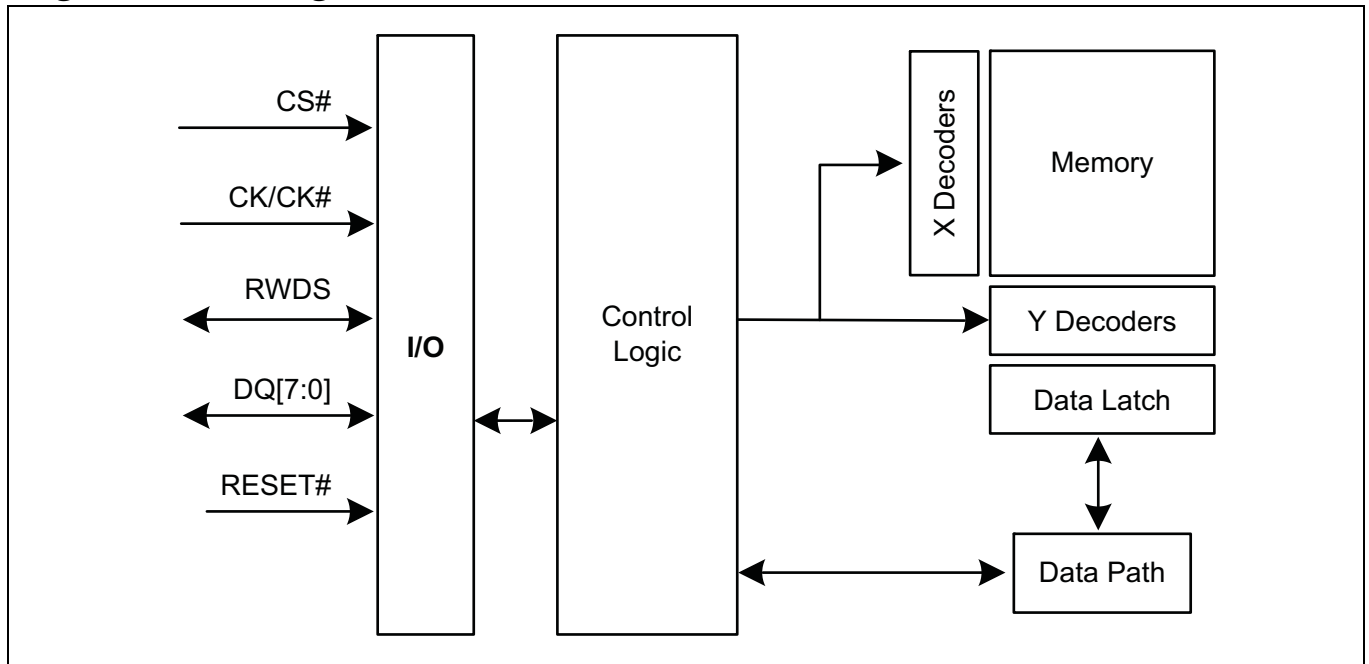

Table of contents

Features	1
Performance summary	2
Logic block diagram	2
Table of contents	3
1 General description	5
1.1 HYPERBUS™ interface	5
2 Product overview	8
2.1 HYPERBUS™ interface	8
3 Signal description	9
3.1 Input/output summary	9
4 HYPERBUS™ transaction details	10
4.1 Command/address bit assignments	10
4.2 Read transactions	15
4.3 Write transactions (Memory array write)	16
4.4 Write transactions without initial latency (Register write)	18
5 Memory space	19
5.1 HYPERBUS™ interface	19
6 Register space	20
6.1 HYPERBUS™ interface	20
6.2 Device identification registers	20
6.2.1 Density and row boundaries	21
6.3 Register space access	21
6.3.1 Configuration register 0	22
6.3.2 Wrapped burst	23
6.3.3 Configuration register 1	26
7 Interface states	28
8 Power conservation modes	29
8.1 Interface standby	29
8.2 Active clock stop	29
8.3 Hybrid sleep	29
8.4 Deep power-down	30
9 Electrical specifications	31
9.1 Absolute maximum ratings[45]	31
9.2 Input signal overshoot	31
9.3 Latch-up characteristics	32
9.4 Operating ranges	32
9.4.1 Temperature ranges	32
9.4.2 Power supply voltages	32
9.5 DC characteristics	33
9.5.1 Capacitance characteristics	37
9.6 Power-up initialization	38
9.7 Power-down	39
9.8 Hardware reset	40
10 Timing specifications	41
10.1 Key to switching waveforms	41
10.2 AC test conditions	41
10.3 Timing reference levels	42
10.4 CLK characteristics	43
10.5 AC characteristics	45
10.5.1 Read transactions	45
10.5.2 Write transactions	47

11 Physical interface	48
11.1 FBGA 24-ball 5 x 5 array footprint	48
12 Package diagram	49
13 DDR center-aligned read strobe (DCARS) functionality	50
13.1 HYPERRAM™ products with DCARS signal descriptions.....	50
13.2 HYPERRAM™ products with DCARS — FBGA 24-ball, 5 x 5 array footprint	51
13.3 HYPERRAM™ memory with DCARS timing	52
14 Ordering information	54
14.1 Ordering part number.....	54
14.2 Valid combinations	55
14.3 Valid combinations — Automotive grade / AEC-Q100.....	56
Revision history	57

1 General description

HYPERRAM™ device, 64 Mb is a high-speed CMOS, self-refresh DRAM, with HYPERBUS™ interface. The DRAM array uses dynamic cells that require periodic refresh. Refresh control logic within the device manages the refresh operations on the DRAM array when the memory is not being actively read or written by the HYPERBUS™ interface master (host). Since the host is not required to manage any refresh operations, the DRAM array appears to the host as though the memory uses static cells that retain data without refresh. Hence, the memory is more accurately described as Pseudo Static RAM (PSRAM).

Since the DRAM cells cannot be refreshed during a read or write transaction, there is a requirement that the host limit read or write burst transfers lengths to allow internal logic refresh operations when they are needed. The host must confine the duration of transactions and allow additional initial access latency, at the beginning of a new transaction, if the memory indicates a refresh operation is needed.

1.1 HYPERBUS™ interface

HYPERBUS™ is a low signal count, DDR interface, that achieves high-speed read and write throughput. The DDR protocol transfers two data bytes per clock cycle on the DQ[7:0] input/output signals. A read or write transaction on HYPERBUS™ consists of a series of 16-bit wide, one clock cycle data transfers at the internal HYPERRAM™ array with two corresponding 8-bit wide, one-half-clock-cycle data transfers on the DQ signals. All inputs and outputs are LV-CMOS compatible. Device are available as 1.8 V V_{CC}/V_{CCQ} or 3.0 V V_{CC}/V_{CCQ} (nominal) for array (V_{CC}) and I/O buffer (V_{CCQ}) supplies, through different Ordering part numbers (OPN).

Command, address, and data information is transferred over the eight HYPERBUS™ DQ[7:0] signals. The clock (CK#, CK) is used for information capture by a HYPERBUS™ slave device when receiving command, address, or data on the DQ signals. Command or address values are center-aligned with clock transitions.

Every transaction begins with the assertion of CS# and Command-address (CA) signals, followed by the start of clock transitions to transfer six CA bytes, followed by initial access latency and either read or write data transfers, until CS# is deasserted.

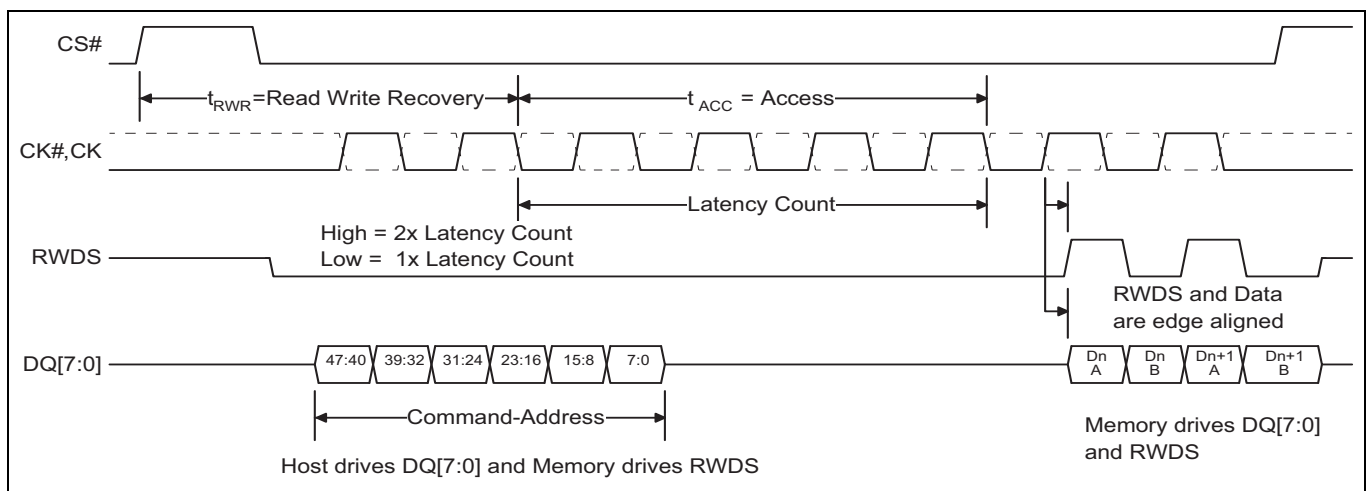

Figure 1 Read transaction, single initial latency count

General description

The RWDS is a bidirectional signal that indicates:

- When data will start to transfer from a HYPERRAM™ device to the master device in read transactions (initial read latency)
- When data is being transferred from a HYPERRAM™ device to the master device during read transactions (as a source synchronous read data strobe)
- When data may start to transfer from the master device to a HYPERRAM™ device in write transactions (initial write latency)
- Data masking during write data transfers

During the CA transfer portion of a read or write transaction, RWDS acts as an output from a HYPERRAM™ device to indicate whether additional initial access latency is needed in the transaction.

During read data transfers, RWDS is a read data strobe with data values edge-aligned with the transitions of RWDS.

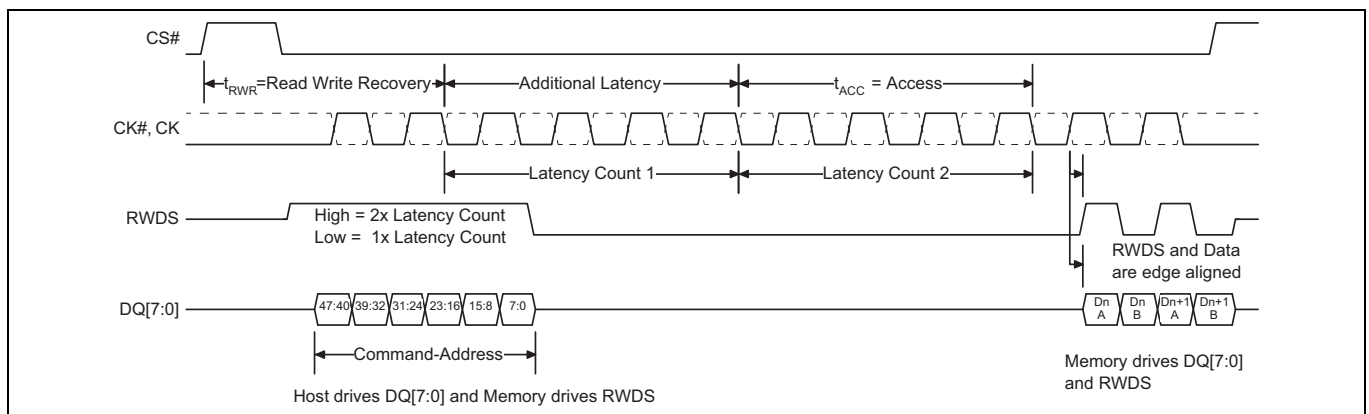

Figure 2 Read transaction, additional latency count

During write data transfers, RWDS indicates whether each data byte transfer is masked with RWDS high (invalid and prevented from changing the byte location in a memory) or not masked with RWDS low (valid and written to a memory). Data masking may be used by the host to byte align write data within a memory or to enable merging of multiple non-word aligned writes in a single burst write. During write transactions, data is center-aligned with clock transitions.

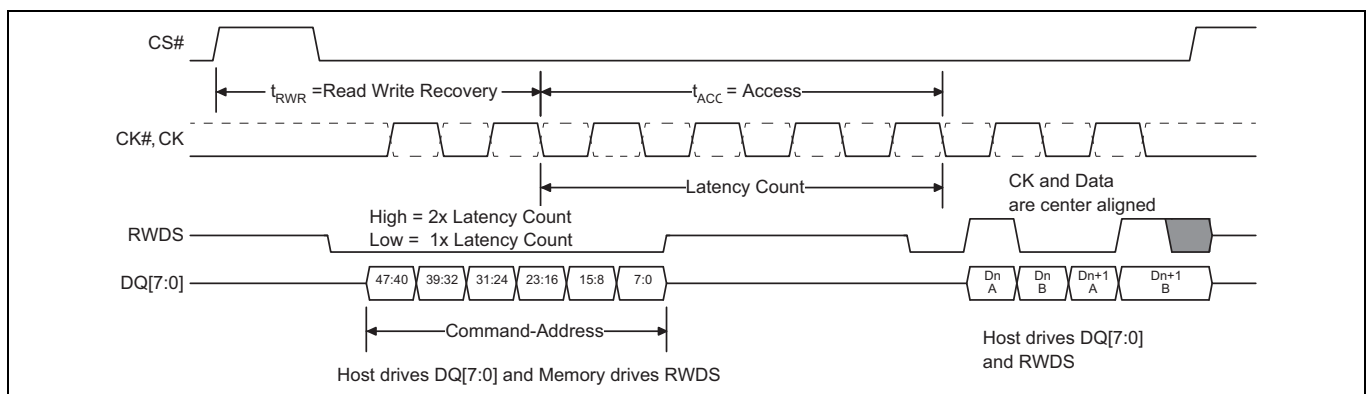

Figure 3 Write transaction, single initial latency count

Read and write transactions are burst oriented, transferring the next sequential word during each clock cycle. Each individual read or write transaction can use either a wrapped or linear burst sequence.

General description

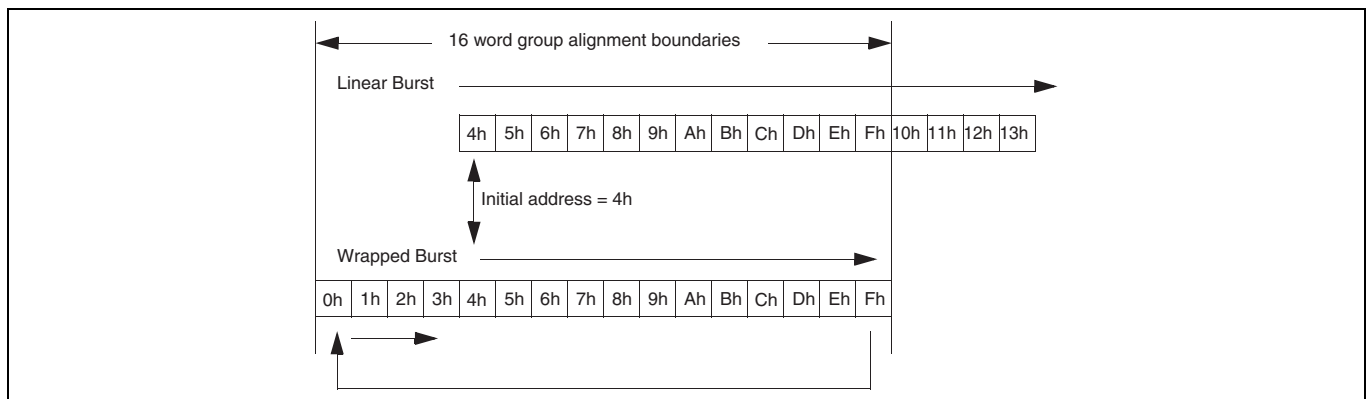

Figure 4 Linear versus wrapped burst sequence

During wrapped transactions, accesses start at a selected location and continue to the end of a configured word group aligned boundary, then wrap to the beginning location in the group, then continue back to the starting location. Wrapped bursts are generally used for critical word first cache line fill read transactions. During linear transactions, accesses start at a selected location and continue in a sequential manner until the transaction is terminated when CS# returns high. Linear transactions are generally used for large contiguous data transfers such as graphic images. Since each transaction command selects the type of burst sequence for that transaction, wrapped and linear bursts transactions can be dynamically intermixed as needed.

2 Product overview

The 64 Mb HYPERRAM™ device is 1.8 V or 3.0 V array and I/O, synchronous self-refresh DRAM. The HYPERRAM™ device provides a HYPERBUS™ slave interface to the host system. The HYPERBUS™ interface has an 8-bit (1 byte) wide DDR data bus and use only word-wide (16-bit data) address boundaries. Read transactions provide 16 bits of data during each clock cycle (8 bits on both clock edges). Write transactions take 16 bits of data from each clock cycle (8 bits on each clock edge).

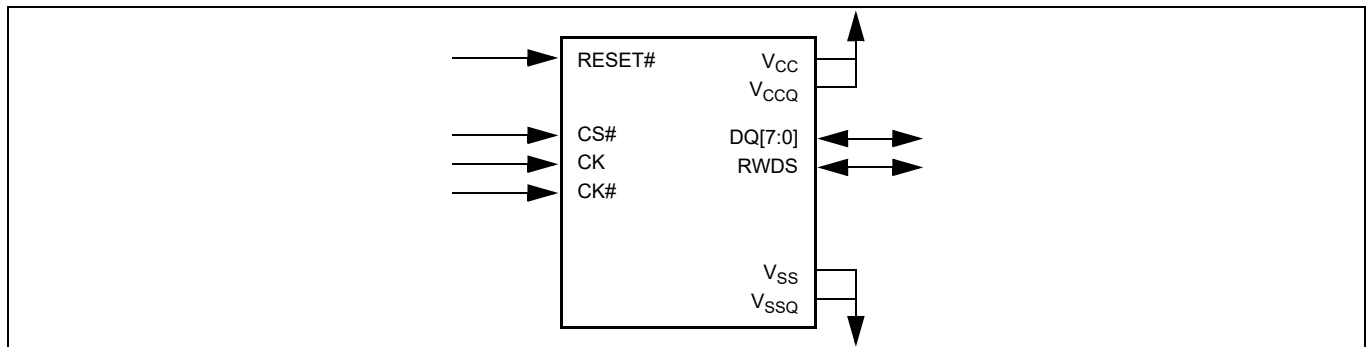

Figure 5 HYPERBUS™ interface^[1]

2.1 HYPERBUS™ interface

Read and write transactions require two clock cycles to define the target row address and burst type, then an initial access latency of t_{ACC} . During the CA part of a transaction, the memory will indicate whether an additional latency for a required refresh time (t_{RFH}) is added to the initial latency; by driving the RWDS signal to the high state. During the CA period, the third clock cycle will specify the target word address within the target row. During a read (or write) transaction, after the initial data value has been output (or input), additional data can be read from (or written to) the row on subsequent clock cycles in either a wrapped or linear sequence. When configured in linear burst mode, the device will automatically fetch the next sequential row from the memory array to support a continuous linear burst. Simultaneously accessing the next row in the array while the read or write data transfer is in progress, allows for a linear sequential burst operation that can provide a sustained data rate of 400 MBps [1 byte (8 bit data bus) * 2 (data clock edges) * 200 MHz = 400 MBps].

Note

1. CK# is used in differential clock mode, but optional.

3 Signal description

3.1 Input/output summary

HYPERRAM™ signals are shown in [Table 1](#). Active low signal names have a hash symbol (#) suffix.

Table 1 I/O summary^[3]

Symbol	Type	Description
CS#	Master output, slave input	Chip Select. Bus transactions are initiated with a high to low transition. Bus transactions are terminated with a low to high transition. The master device has a separate CS# for each slave.
CK, CK#[2]	Master output, slave input	Differential clock. Command, address, and data information is output with respect to the crossing of the CK and CK# signals. Use of differential clock is optional. Single ended clock. CK# is not used, only a single ended CK is used. The clock is not required to be free-running.
DQ[7:0]	Input/output	Data Input/output. Command, Address, and Data information is transferred on these signals during read and write transactions.
RWDS	Input/output	Read-write data strobe. During the Command/address portion of all bus transactions, RWDS is a slave output and indicates whether additional initial latency is required. Slave output during read data transfer, data is edge-aligned with RWDS. Slave input during data transfer in write transactions to function as a data mask. (High = additional latency, Low= no additional latency).
RESET#	Master output, slave input, Internal pull-up	Hardware reset. When low, the slave device will self initialize and return to the standby state. RWDS and DQ[7:0] are placed into the high-Z state when Reset# is low. The slave Reset# input includes a weak pull-up, if Reset# is left unconnected it will be pulled up to the high state.
V _{CC}	Power supply	Array power.
V _{CCQ}	Power supply	Input/output power.
V _{SS}	Power supply	Array ground.
V _{SSQ}	Power supply	Input/output ground.
RFU	No connect	Reserved for future use. May or may not be connected internally, the signal/ball location should be left unconnected and unused by PCB routing channel for future compatibility. The signal/ball may be used by a signal in the future.

Notes

- CK# is used in Differential clock mode, but optional connection. Tie the CK# input pin to either V_{CCQ} or V_{SSQ} if not connected to the host controller, but do not leave it floating.
- Optional Center-Aligned Read Strobe (DCARS) pinout and pin description are outlined in [“DDR center-aligned read strobe \(DCARS\) functionality”](#) on page 50.

4 HYPERBUS™ transaction details

4.1 Command/address bit assignments

All HYPERRAM™ bus transactions can be classified as either read or write. A bus transaction is started with CS# going low with clock in idle state (CK = low and CK# = high). The first three clock cycles transfer three words of command/address (CA0, CA1, CA2) information to define the transaction characteristics. The command/address words are presented with DDR timing, using the first six clock edges.

The following characteristics are defined by the command/address information:

- Read or write transaction
- Address space: Memory array space or register space
 - Register space is used to access Device identification (ID) registers and Configuration registers (CR) that identify the device characteristics and determine the slave specific behavior of read and write transfers on the HYPERBUS™ interface.
- Whether a transaction will use a linear or wrapped burst sequence.
- The target row (and half-page) address (upper order address)
- The target column (word within half-page) address (lower order address)

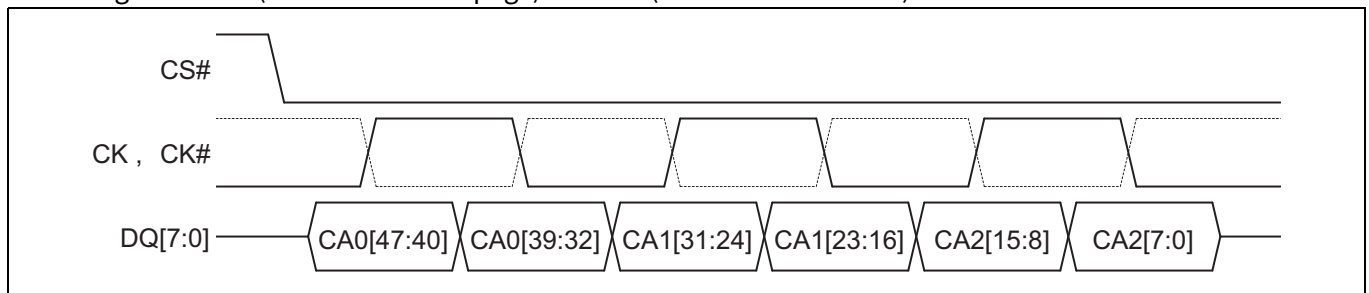

Figure 6 Command/address (CA) sequence^[4-7]

Table 2 CA bit assignment to DQ signals

Signal	CA0[47:40]	CA0[39:32]	CA1[31:24]	CA1[23:16]	CA2[15:8]	CA2[7:0]
DQ[7]	CA[47]	CA[39]	CA[31]	CA[23]	CA[15]	CA[7]
DQ[6]	CA[46]	CA[38]	CA[30]	CA[22]	CA[14]	CA[6]
DQ[5]	CA[45]	CA[37]	CA[29]	CA[21]	CA[13]	CA[5]
DQ[4]	CA[44]	CA[36]	CA[28]	CA[20]	CA[12]	CA[4]
DQ[3]	CA[43]	CA[35]	CA[27]	CA[19]	CA[11]	CA[3]
DQ[2]	CA[42]	CA[34]	CA[26]	CA[18]	CA[10]	CA[2]
DQ[1]	CA[41]	CA[33]	CA[25]	CA[17]	CA[9]	CA[1]
DQ[0]	CA[40]	CA[32]	CA[24]	CA[16]	CA[8]	CA[0]

Notes

4. **Figure 6** shows the initial three clock cycles of all transactions on the HYPERBUS™.
5. CK# of differential clock is shown as dashed line waveform.
6. CA information is “center-aligned” with the clock during both read and write transactions.
7. Data bits in each byte are always in high to low order with bit 7 on DQ7 and bit 0 on DQ0.

64-Mb HYPERRAM™ self-refresh DRAM (PSRAM)
HYPERBUS™ interface, 1.8 V/3.0 V



HYPERBUS™ transaction details

Table 3 Command/address bit assignments^[8-11]

CA bit#	Bit name	Bit function
47	R/W#	Identifies the transaction as a read or write. R/W# = 1 indicates a read transaction R/W# = 0 indicates a write transaction
46	Address space (AS)	Indicates whether the read or write transaction accesses the memory or register space. AS = 0 indicates memory space AS = 1 indicates the register space The register space is used to access device ID and configuration registers.
45	Burst type	Indicates whether the burst will be linear or wrapped. Burst type = 0 indicates wrapped burst Burst type = 1 indicates linear burst
44-16	Row and upper column address	Row and upper column component of the target address: System word address bits A31-A3. Any upper Row address bits not used by a particular device density should be set to 0 by the host controller master interface. The size of Rows and therefore the address bit boundary between row and column address is slave device dependent.
15-3	Reserved	Reserved for future column address expansion. Reserved bits are don't care in current HYPERBUS™ devices but should be set to 0 by the host controller master interface for future compatibility.
2-0	Lower column address	Lower column component of the target address: System word address bits A2-A0 selecting the starting word within a half-page.

Notes

8. A row is a group of words relevant to the internal memory array structure. The number of Rows is also used in the calculation of a distributed refresh interval for HYPERRAM™ memory.
9. The Column address selects the burst transaction starting word location within a Row. The Column address is split into an upper and lower portion. The upper portion selects an 8-word (16-byte) half-page and the lower portion selects the word within a half-page where a read or write transaction burst starts.
10. The initial read access time starts when the row and upper column (half-page) address bits are captured by a slave interface. Continuous linear read burst is enabled by memory devices internally interleaving access to 16 byte half-pages.
11. HYPERBUS™ protocol address space limit, assuming:
 - 29 Row and upper column address bits
 - 3 Lower column address bits
 - Each address selects a word wide (16 bit = 2 byte) data value
 - 29 + 3 = 32 address bits = 4G addresses supporting 8GB (64Gb) maximum address space
 - future expansion of the column address can allow for 29 row and upper column + 16 lower column address bits = 35 tera-word = 70 tera-byte address space.

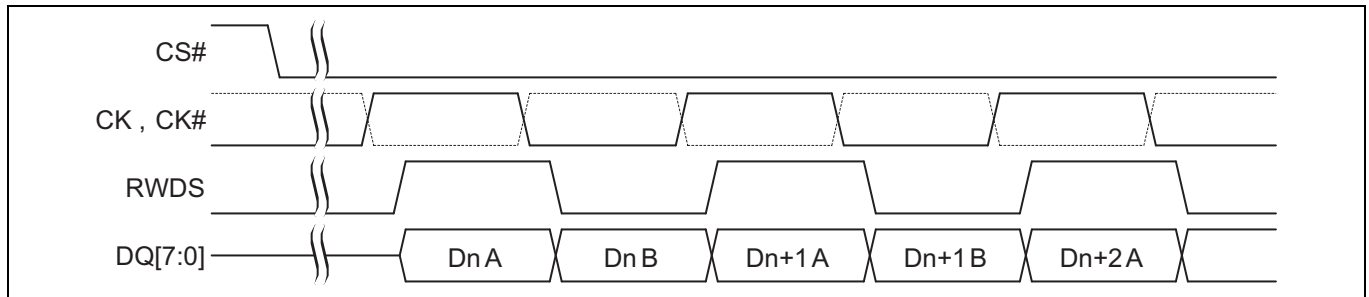

Figure 7 Data placement during a read transaction^[12-16]

Data placement during memory read/write is dependent upon the host. The device will output data (read) as it was written in (write). Hence both Big endian and Little endian are supported for the memory array.

Data placement during register read/write is Big endian.

Notes

12. **Figure 7** shows a portion of a read transaction on the HYPERBUS™. CK# of differential clock is shown as dashed line waveform.
13. Data is “edge-aligned” with the RWDS serving as a read data strobe during read transactions.
14. Data is always transferred in full word increments (word granularity transfers).
15. Word address increments in each clock cycle. Byte A is between RWDS rising and falling edges and is followed by byte B between RWDS falling and rising edges, of each word.
16. Data bits in each byte are always in high to low order with bit 7 on DQ7 and bit 0 on DQ0.

Table 4 Data bit placement during read or write transaction

Address space	Byte order	Byte position	Word data bit	DQ	Bit order
Memory	Big-endian	A	15	7	<p>When data is being accessed in memory space: The first byte of each word read or written is the “A” byte and the second is the “B” byte. The bits of the word within the A and B bytes depend on how the data was written. If the word lower address bits 7-0 are written in the A byte position and bits 15-8 are written into the B byte position, or vice versa, they will be read back in the same order.</p> <p>Memory space can be stored and read in either little-endian or big-endian order.</p>
			14	6	
			13	5	
			12	4	
			11	3	
			10	2	
			9	1	
			8	0	
		B	7	7	
			6	6	
			5	5	
			4	4	
			3	3	
			2	2	
			1	1	
			0	0	
Memory	Little-endian	A	7	7	<p>When data is being accessed in memory space: The first byte of each word read or written is the “A” byte and the second is the “B” byte. The bits of the word within the A and B bytes depend on how the data was written. If the word lower address bits 7-0 are written in the A byte position and bits 15-8 are written into the B byte position, or vice versa, they will be read back in the same order.</p> <p>Memory space can be stored and read in either little-endian or big-endian order.</p>
			6	6	
			5	5	
			4	4	
			3	3	
			2	2	
			1	1	
			0	0	
		B	15	7	
			14	6	
			13	5	
			12	4	
			11	3	
			10	2	
			9	1	
			8	0	

Table 4 Data bit placement during read or write transaction (Continued)

Address space	Byte order	Byte position	Word data bit	DQ	Bit order
Register	Big-endian	A	15	7	<p>When data is being accessed in register space: During a Read transaction on the HYPERBUS™ two bytes are transferred on each clock cycle. The upper order byte A (word[15:8]) is transferred between the rising and falling edges of RWDS (edge-aligned). The lower order byte B (word[7:0]) is transferred between the falling and rising edges of RWDS.</p> <p>During a write, the upper order byte A (word[15:8]) is transferred on the CK rising edge and the lower order byte B (word[7:0]) is transferred on the CK falling edge. So, register space is always read and written in big-endian order because registers have device dependent fixed bit location and meaning definitions.</p>
			14	6	
			13	5	
			12	4	
			11	3	
			10	2	
			9	1	
			8	0	
		B	7	7	
			6	6	
			5	5	
			4	4	
			3	3	
			2	2	
			1	1	
0	0				

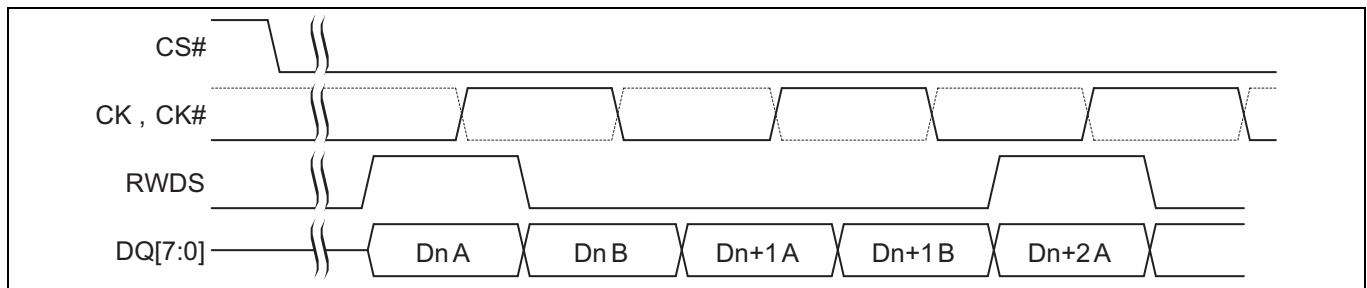

Figure 8 Data placement during a write transaction^[17-20]

Notes

- 17. **Figure 8** shows a portion of a Write transaction on the HYPERBUS™.
- 18. Data is “center-aligned” with the clock during a write transaction.
- 19. RWDS functions as a data mask during write data transfers with initial latency. Masking of the first and last byte is shown to illustrate an unaligned 3 byte write of data.
- 20. RWDS is not driven by the master during write data transfers with zero initial latency. Full data words are always written in this case. RWDS may be driven low or left high-Z by the slave in this case.

4.2 Read transactions

The HYPERBUS™ master begins a transaction by driving CS# low while clock is idle. The clock then begins toggling while CA words are transferred.

In CA0, CA[47] = 1 indicates that a Read transaction is to be performed. CA[46] = 0 indicates the memory space is being read or CA[46] = 1 indicates the register space is being read. CA[45] indicates the burst type (wrapped or linear). Read transactions can begin the internal array access as soon as the row and upper column address has been presented in CA0 and CA1 (CA[47:16]). CA2 (CA[15:0]) identifies the target word address within the chosen row.

The HYPERBUS™ master then continues clocking for a number of cycles defined by the latency count setting in Configuration Register 0. The initial latency count required for a particular clock frequency is based on RWDS. If RWDS is low during the CA cycles, one latency count is inserted. If RWDS is high during the CA cycles, an additional latency count is inserted. Once these latency clocks have been completed the memory starts to simultaneously transition the RWDS and output the target data.

New data is output edge-aligned with every transition of RWDS. Data will continue to be output as long as the host continues to transition the clock while CS# is low. Note that burst transactions should not be so long as to prevent the memory from doing distributed refreshes.

Wrapped bursts will continue to wrap within the burst length and linear burst will output data in a sequential manner across row boundaries. When a linear burst read reaches the last address in the array, continuing the burst beyond the last address will provide data from the beginning of the address range. Read transfers can be ended at any time by bringing CS# high when the clock is idle.

The clock is not required to be free-running. The clock may remain idle while CS# is high.

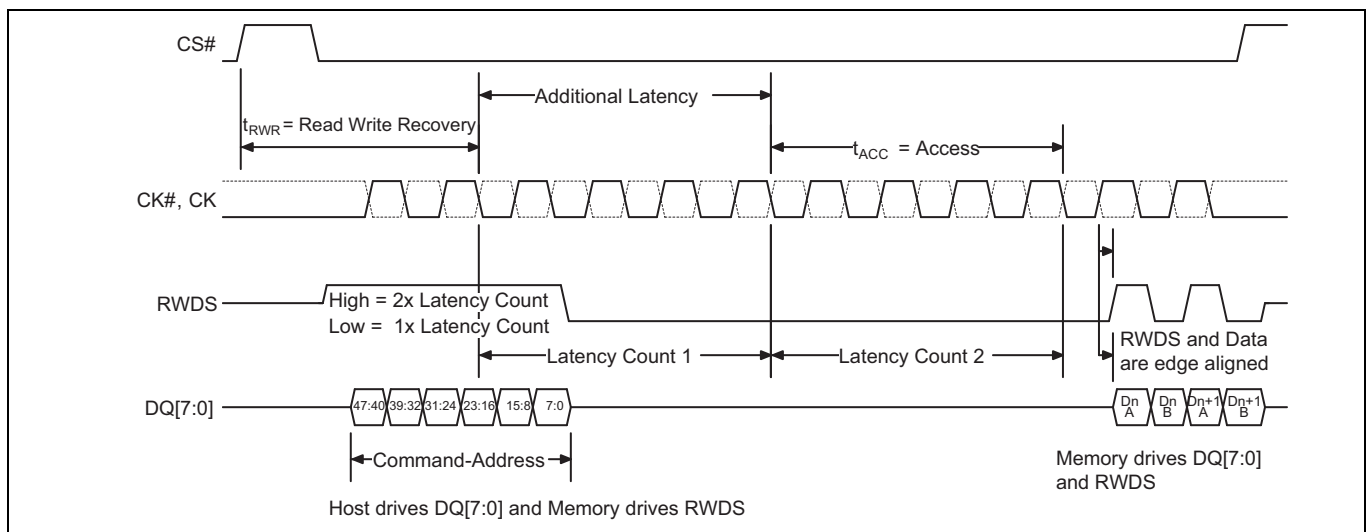

Figure 9 Read transaction with additional initial latency^[21-28]

Notes

21. **Figure 8** shows a portion of a Write transaction on the HYPERBUS™.
22. Data is “center-aligned” with the clock during a write transaction.
23. RWDS functions as a data mask during write data transfers with initial latency. Masking of the first and last byte is shown to illustrate an unaligned 3 byte write of data.
24. RWDS is not driven by the master during write data transfers with zero initial latency. Full data words are always written in this case. RWDS may be driven low or left high-Z by the slave in this case.
25. The read latency is defined by the initial latency value in a configuration register.
26. In this read transaction example the initial latency count was set to four clocks.
27. In this read transaction a RWDS high indication during CA delays output of target data by an additional four clocks.
28. The memory device drives RWDS during read transactions.

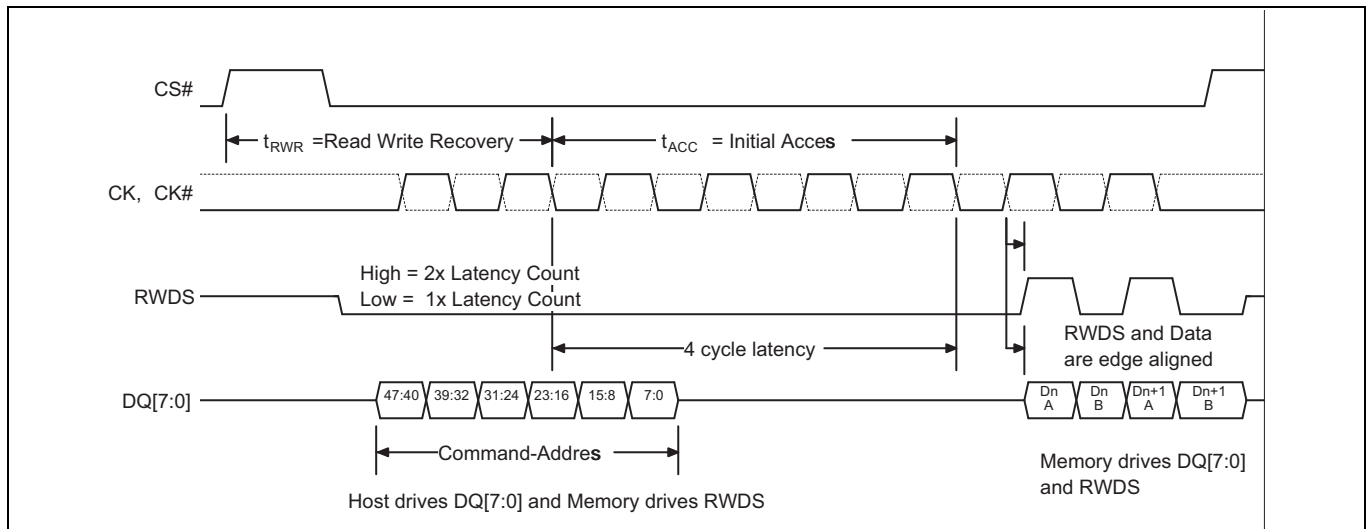

Figure 10 Read transaction without additional initial latency^[29]

4.3 Write transactions (Memory array write)

The HyperBus master begins a transaction by driving CS# LOW while clock is idle. Then the clock begins toggling while CA words are transferred.

In CA0, CA[47] = 0 indicates that a Write transaction is to be performed. CA[46] = 0 indicates the memory space is being written. CA[45] indicates the burst type (wrapped or linear). Write transactions can begin the internal array access as soon as the row and upper column address has been presented in CA0 and CA1 (CA[47:16]). CA2 (CA[15:0]) identifies the target word address within the chosen row.

The HyperBus master then continues clocking for a number of cycles defined by the latency count setting in configuration register 0. The initial latency count required for a particular clock frequency is based on RWDS. If RWDS is LOW during the CA cycles, one latency count is inserted. If RWDS is HIGH during the CA cycles, an additional latency count is inserted.

Once these latency clocks have been completed, the HyperBus master starts to output the target data. Write data is center-aligned with the clock edges. The first byte of data in each word is captured by the memory on the rising edge of CK and the second byte is captured on the falling edge of CK.

During the CA clock cycles, RWDS is driven by the memory.

During the write data transfers, RWDS is driven by the host master interface as a data mask. When data is being written and RWDS is HIGH, the byte will be masked and the array will not be altered. When data is being written and RWDS is LOW, the data will be placed into the array. Because the master is driving RWDS during write data transfers, neither the master nor the HyperRAM device are able to indicate a need for latency within the data transfer portion of a write transaction. The acceptable write data burst length setting is also shown in configuration register 0.

Data will continue to be transferred as long as the HyperBus master continues to transition the clock while CS# is LOW. Note that burst transactions should not be so long as to prevent the memory from doing distributed refreshes. Legacy format wrapped bursts will continue to wrap within the burst length. Hybrid wrap will wrap once then switch to linear burst starting at the next wrap boundary. Linear burst accepts data in a sequential manner across page boundaries. Write transfers can be ended at any time by bringing CS# HIGH when the clock is idle.

When a linear burst write reaches the last address in the memory array space, continuing the burst will write to the beginning of the address range.

The clock is not required to be free-running. The clock may remain idle while CS# is HIGH.

Note

29. RWDS is LOW during the CA cycles. In this Read Transaction, there is a single initial latency count for read data access because, this read transaction does not begin at a time when additional latency is required by the slave.

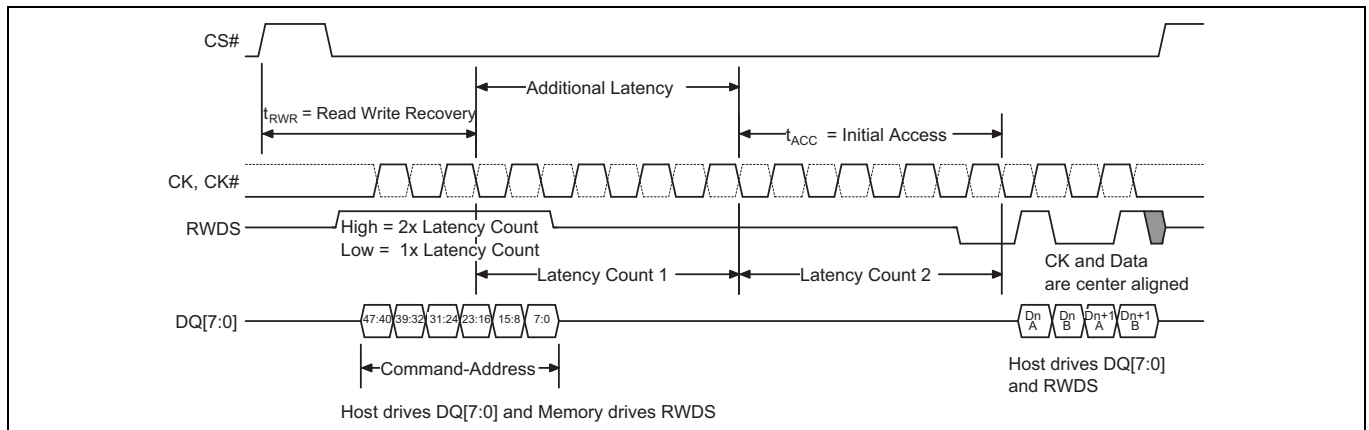

Figure 11 Write transaction with additional initial latency^[30-36]

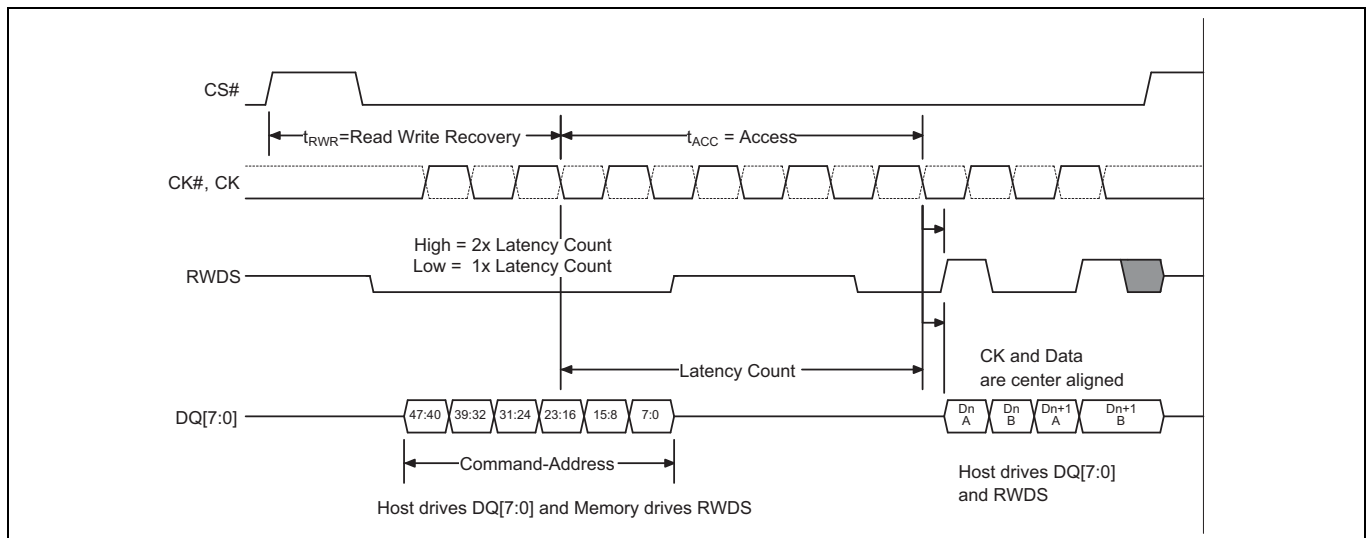

Figure 12 Write transaction without additional initial latency^[32-36]

Notes

- 30. Transactions must be initiated with CK = low and CK# = high.
- 31. CS# must return high before a new transaction is initiated.
- 32. During CA, RWDS is driven by the memory and indicates whether additional latency cycles are required.
- 33. In this example, RWDS indicates that additional initial latency cycles are required.
- 34. At the end of CA cycles the memory stops driving RWDS to allow the host HYPERBUS™ master to begin driving RWDS. The master must drive RWDS to a valid low before the end of the initial latency to provide a data mask preamble period to the slave.
- 35. During data transfer, RWDS is driven by the host to indicate which bytes of data should be either masked or loaded into the array.
- 36. The figure shows RWDS masking byte Dn A and byte Dn+1 B to perform an unaligned word write to bytes Dn B and Dn+1 A.

4.4 Write transactions without initial latency (Register write)

A write transaction starts with the first three clock cycles providing the command/address information indicating the transaction characteristics. CA0 may indicate that a Write transaction is to be performed and also indicates the address space and burst type (wrapped or linear).

Writes without initial latency are used for register space writes. HYPERRAM™ device write transactions with zero latency mean that the CA cycles are followed by write data transfers. Writes with zero initial latency, do not have a turn around period for RWDS. The HYPERRAM™ device will always drive RWDS during the CA period to indicate whether extended latency is required for a transaction that has initial latency. However, the RWDS is driven before the HYPERRAM™ device has received the first byte of CA i.e., before the HYPERRAM™ device knows whether the transaction is a read or write to register space. In the case of a write with zero latency, the RWDS state during the CA period does not affect the initial latency of zero. Since master write data immediately follows the CA period in this case, the HYPERRAM™ device may continue to drive RWDS low or may take RWDS to High-Z during write data transfer. The master must not drive RWDS during Writes with zero latency. Writes with zero latency do not use RWDS as a data mask function. All bytes of write data are written (full word writes).

The first byte of data in each word is presented on the rising edge of CK and the second byte is presented on the falling edge of CK. Write data is center-aligned with the clock inputs. Write transfers can be ended at any time by bringing CS# high when clock is idle. The clock is not required to be free-running.

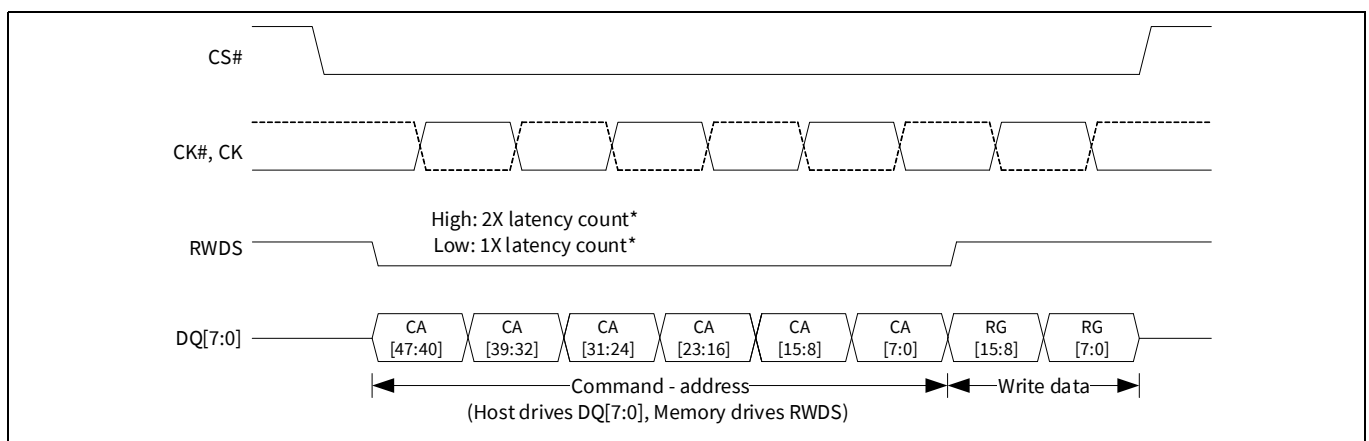

Figure 13 Write operation without initial latency^[37]

Note

37. Latency count is not applicable for Register write. The RWDS driven low or high during CA cycle should be ignored by the host and the host must continue register write with zero latency.

Memory space

5 Memory space

5.1 HYPERBUS™ interface

Table 5 Memory space address map (word based - 16 bits)

Unit type	Count	System word address bits	CA bits	Notes
Rows within 64 Mb device	8192 (rows)	A21 - A9	34 - 22	–
Row	1 (row)	A8 - A3	21 - 16	512 (word addresses) 1 KB
Half-page	8 (word addresses)	A2 - A0	2 - 0	8 words (16 bytes)

Register space

6 Register space

6.1 HYPERBUS™ interface

When CA[46] is 1, a read or write transaction accesses the Register space.

Table 6 Register space address map

Register	System address	—	—	—	31-27	26-19	18-11	10-3	—	2-0
	CA bits	47	46	45 ^[38]	44-40	39-32	31-24	23-16	15-8	7-0
Identification register 0 Read ^[39]	C0h or E0h				00h	00h	00h	00h	00h	00h
Identification register 1 read ^[39]	C0h or E0h				00h	00h	00h	00h	00h	01h
Configuration register 0 read	C0h or E0h				00h	01h	00h	00h	00h	00h
Configuration register 0 write	60h				00h	01h	00h	00h	00h	00h
Configuration register 1 read	C0h or E0h				00h	01h	00h	00h	00h	01h
Configuration register 1 write	60h				00h	01h	00h	00h	00h	01h
Die manufacture information register (0-17) read	C0h or E0h				00h	02h	00h	00h	00h	00h - 11h

6.2 Device identification registers

There are two read only, nonvolatile word registers, that provide information on the device selected when CS# is low.

The device information fields identify:

- Manufacturer
- Type
- Density
 - Row address bit count
 - Column address bit count

Notes

38. CA45 may be either 0 or 1 for either wrapped or linear read. CA45 must be 1 as only linear single word register writes are supported.

39. The burst type (wrapped/linear) definition is not supported in register reads. Hence C0h/E0h have the same effect.

Register space

Table 7 Identification register 0 (ID0) bit assignments

Bits	Functions	Settings (binary)
[15:4]	MCP die address	00 - Default
[13]	Reserved	0 - Default
[12:8]	Row address bit count	00000 - One row address bit ... 11111 - Thirty-two row address bits ... 01100 - 64 Mb - Thirteen row address bits (default)
[7:4]	Column address bit count	0000 - One column address bits ... 1000 - Nine column address bits (default) ... 1111 - Sixteen column address bits
[3:0]	Manufacturer	0001 - Infineon 0000, 0010 to 1111 - Reserved

Table 8 Identification register 1 (ID1) bit assignments

Bits	Functions	Settings (binary)
[15:4]	Reserved	0000_0000_0000 (default)
[3:0]	Device type	0001 - HYPERRAM™ 2.0 0000, 0010 to 1111 - Reserved

6.2.1 Density and row boundaries

The DRAM array size (density) of the device can be determined from the total number of system address bits used for the row and column addresses as indicated by the row address bit count and column address bit count fields in the ID0 register. For example: a 64 Mb HYPERRAM™ device has 9 column address bits and 13 row address bits for a total of 22 word address bits = $2^{22} = 4 \text{ Mwords} = 8 \text{ MB}$. The 9 column address bits indicate that each row holds $2^9 = 512 \text{ words} = 1 \text{ KB}$. The row address bit count indicates there are 8196 rows to be refreshed within each array refresh interval. The row count is used in calculating the refresh interval.

ID0 value for the 64 Mb HYPERRAM™ is 0x0C81.

6.3 Register space access

Register default values are loaded upon power-up or hardware reset. The registers can be altered at any time while the device is in the standby state.

Loading a register is accomplished with write transaction without initial latency using a single 16-bit word write transaction.

Each register is written with a separate single word write transaction. Register write transactions have zero latency, the single word of data immediately follows the CA. RWDS is not driven by the host during the write because RWDS is always driven by the memory during the CA cycles to indicate whether a memory array refresh is in progress. Because a register space write goes directly to a register, rather than the memory array, there is no initial write latency, related to an array refresh that may be in progress. In a register write, RWDS is also not used as a data mask because both bytes of a register are always written and never masked.

Reserved register fields must be written with their default value. Writing reserved fields with other than default values may produce undefined results.

Register space

Notes

- The host must not drive RWDS during a write to register space.
- The RWDS signal is driven by the memory during the CA period based on whether the memory array is being refreshed. This refresh indication does not affect the writing of register data.
- The RWDS signal returns to high impedance after the CA period. Register data is never masked. Both data bytes of the register data are loaded into the selected register.

Reading of a register is accomplished with read transaction with single or double initial latency using a single 16 bit read transaction. If more than one word is read, the output becomes indeterminate. The contents of the register is returned in the same manner as reading the memory array, as shown in **Figure 9**, with one or two latency counts, based on the state of RWDS during the CA period. The latency count is defined in the Configuration Register 0 Read Latency field (CR0[7:4]).

6.3.1 Configuration register 0

Configuration register 0 (CR0) is used to define the power state and access protocol operating conditions for the HYPERRAM™ device. Configurable characteristics include:

- Wrapped burst length (16, 32, 64, or 128 byte aligned and length data group)
- Wrapped burst type
 - Legacy wrap (Sequential access with wrap around within a selected length and aligned group)
 - Hybrid wrap (Legacy wrap once then linear burst at start of the next sequential group)
- Initial latency
- Variable latency
 - Whether an array read or write transaction will use fixed or variable latency. If fixed latency is selected the memory will always indicate a refresh latency and delay the read data transfer accordingly. If variable latency is selected, latency for a refresh is only added when a refresh is required at the same time a new transaction is starting.
- Output drive strength
- Deep power-down (DPD) mode

Table 9 Configuration register 0 (CR0) bit assignments

CR0 Bit	Function	Settings (binary)
[15]	Deep power-down enable	1 - Normal operation (default). HYPERRAM™ will automatically set this value to “1” after DPD exit 0 - Writing 0 causes the device to enter Deep power-down
[14:12]	Drive strength	000 - 34 ohms (default) 001 - 115 ohms 010 - 67 ohms 011 - 46 ohms 100 - 34 ohms 101 - 27 ohms 110 - 22 ohms 111 - 19 ohms
[11:8]	Reserved	1 - Reserved (default) Reserved for future use. When writing this register, these bits should be set to 1 for future compatibility.

Register space

Table 9 Configuration register 0 (CR0) bit assignments (Continued)

CR0 Bit	Function	Settings (binary)
[7:4]	Initial latency	0000 - 5 Clock latency @ 133 MHz Max frequency 0001 - 6 Clock latency @ 166 MHz Max frequency 0010 - 7 Clock latency @ 200 MHz/166 MHz Max frequency (default) 0011 - Reserved 0100 - Reserved ... 1101 - Reserved 1110 - 3 Clock latency @ 85 MHz Max frequency 1111 - 4 Clock latency @ 104 MHz Max frequency
[3]	Fixed latency enable	0 - Variable Latency - 1 or 2 times Initial Latency depending on RWDS during CA cycles. 1 - Fixed 2 times Initial Latency (default)
[2]	Hybrid burst enable	0: Wrapped burst sequence to follow hybrid burst sequencing 1: Wrapped burst sequence in legacy wrapped burst manner (default) This bit setting is effective only when the "Burst type" bit in the Command/Address register is set to '0', i.e. CA[45] = '0'; otherwise, it is ignored.
[1:0]	Burst length	00 - 128 bytes 01 - 64 bytes 10 - 16 bytes 11 - 32 bytes (default)

6.3.2 Wrapped burst

A wrapped burst transaction accesses memory within a group of words aligned on a word boundary matching the length of the configured group. Wrapped access groups can be configured as 16, 32, 64, or 128 bytes alignment and length. During wrapped transactions, access starts at the CA selected location within the group, continues to the end of the configured word group aligned boundary, then wraps around to the beginning location in the group, then continues back to the starting location. Wrapped bursts are generally used for critical word first instruction or data cache line fill read accesses.

6.3.2.1 Hybrid burst

The beginning of a hybrid burst will wrap within the target address wrapped burst group length before continuing to the next half-page of data beyond the end of the wrap group. Continued access is in linear burst order until the transfer is ended by returning CS# high. This hybrid of a wrapped burst followed by a linear burst starting at the beginning of the next burst group, allows multiple sequential address cache lines to be filled in a single access. The first cache line is filled starting at the critical word. Then the next sequential line in memory can be read in to the cache while the first line is being processed.

Table 10 CR0[2] control of wrapped burst sequence

Bit	Default value	Name
2	1	Hybrid burst enable CR0[2] = 0: Wrapped burst sequence to follow hybrid burst sequencing CR0[2] = 1: Wrapped burst sequence in legacy wrapped burst manner

Register space

Table 11 Example wrapped burst sequences (HYPERBUS™ addressing)

Burst type	Wrap boundary (bytes)	Start address (hex)	Sequence of word addresses (hex) of data words
Hybrid 128	128 wrap once then linear	XXXXXX03	03, 04, 05, 06, 07, 08, 09, 0A, 0B, 0C, 0D, 0E, 0F, 10, 11, 12, 13, 14, 15, 16, 17, 18, 19, 1A, 1B, 1C, 1D, 1E, 1F, 20, 21, 22, 23, 24, 25, 26, 27, 28, 29, 2A, 2B, 2C, 2D, 2E, 2F, 30, 31, 32, 33, 34, 35, 36, 37, 38, 39, 3A, 3B, 3C, 3D, 3E, 3F, 00, 01, 02 (Wrap complete, now linear beyond the end of the initial 128 byte wrap group) 40, 41, 42, 43, 44, 45, 46, 47, 48, 49, 4A, 4B, 4C, 4D, 4E, 4F, 50, 51, ...
Hybrid 64	64 wrap once then linear	XXXXXX03	03, 04, 05, 06, 07, 08, 09, 0A, 0B, 0C, 0D, 0E, 0F, 10, 11, 12, 13, 14, 15, 16, 17, 18, 19, 1A, 1B, 1C, 1D, 1E, 1F, 00, 01, 02 (wrap complete, now linear beyond the end of the initial 64 byte wrap group) 20, 21, 22, 23, 24, 25, 26, 27, 28, 29, 2A, 2B, 2C, 2D, 2E, 2F, 30, 31, ...
Hybrid 64	64 wrap once then linear	XXXXXX2E	2E, 2F, 30, 31, 32, 33, 34, 35, 36, 37, 38, 39, 3A, 3B, 3C, 3D, 3E, 3F, 20, 21, 22, 23, 24, 25, 26, 27, 28, 29, 2A, 2B, 2C, 2D (wrap complete, now linear beyond the end of the initial 64 byte wrap group) 40, 41, 42, 43, 44, 45, 46, 47, 48, 49, 4A, 4B, 4C, 4D, 4E, 4F, 50, 51, ...
Hybrid 16	16 wrap once then linear	XXXXXX02	02, 03, 04, 05, 06, 07, 00, 01 (wrap complete, now linear beyond the end of the initial 16 byte wrap group) 08, 09, 0A, 0B, 0C, 0D, 0E, 0F, 10, 11, 12, ...
Hybrid 16	16 wrap once then linear	XXXXXX0C	0C, 0D, 0E, 0F, 08, 09, 0A, 0B (wrap complete, now linear beyond the end of the initial 16 byte wrap group) 10, 11, 12, 13, 14, 15, 16, 17, 18, 19, 1A, ...
Hybrid 32	32 wrap once then linear	XXXXXX0A	0A, 0B, 0C, 0D, 0E, 0F, 00, 01, 02, 03, 04, 05, 06, 07, 08, 09 (wrap complete, now linear beyond the end of the initial 32 byte wrap group) 10, 11, 12, 13, 14, 15, 16, 17, 18, 19, 1A, ...
Wrap 64	64	XXXXXX03	03, 04, 05, 06, 07, 08, 09, 0A, 0B, 0C, 0D, 0E, 0F, 10, 11, 12, 13, 14, 15, 16, 17, 18, 19, 1A, 1B, 1C, 1D, 1E, 1F, 00, 01, 02, ...
Wrap 64	64	XXXXXX2E	2E, 2F, 30, 31, 32, 33, 34, 35, 36, 37, 38, 39, 3A, 3B, 3C, 3D, 3E, 3F, 20, 21, 22, 23, 24, 25, 26, 27, 28, 29, 2A, 2B, 2C, 2D, ...
Wrap 16	16	XXXXXX02	02, 03, 04, 05, 06, 07, 00, 01, ...
Wrap 16	16	XXXXXX0C	0C, 0D, 0E, 0F, 08, 09, 0A, 0B, ...
Wrap 32	32	XXXXXX0A	0A, 0B, 0C, 0D, 0E, 0F, 00, 01, 02, 03, 04, 05, 06, 07, 08, 09, ...
Linear	Linear burst	XXXXXX03	03, 04, 05, 06, 07, 08, 09, 0A, 0B, 0C, 0D, 0E, 0F, 10, 11, 12, 13, 14, 15, 16, 17, 18, ...

6.3.2.2 Initial latency

Memory space read and write transactions or Register Space read transactions require some initial latency to open the row selected by the CA. This initial latency is t_{ACC} . The number of latency clocks needed to satisfy t_{ACC} depends on the HYPERBUS™ frequency can vary from 3 to 7 clocks. The value in CR0[7:4] selects the number of clocks for initial latency. The default value is 7 clocks, allowing for operation up to a maximum frequency of 200 MHz prior to the host system setting a lower initial latency value that may be more optimal for the system.

In the event a distributed refresh is required at the time a Memory space read or write transaction or Register space read transaction begins, the RWDS signal goes high during the CA to indicate that an additional initial latency is being inserted to allow a refresh operation to complete before opening the selected row.

Register space write transactions always have zero initial latency. RWDS may be high or low during the CA period. The level of RWDS during the CA period does not affect the placement of register data immediately after the CA, as there is no initial latency needed to capture the register data. A refresh operation may be performed in the memory array in parallel with the capture of register data.

6.3.2.3 Fixed latency

A configuration register option bit CR0[3] is provided to make all Memory Space read and write transactions or Register Space read transactions require the same initial latency by always driving RWDS high during the CA to indicate that two initial latency periods are required. This fixed initial latency is independent of any need for a distributed refresh, it simply provides a fixed (deterministic) initial latency for all of these transaction types. The fixed latency option may simplify the design of some HYPERBUS™ memory controllers or ensure deterministic transaction performance. Fixed latency is the default POR or reset configuration. The system may clear this configuration bit to disable fixed latency and allow variable initial latency with RWDS driven high only when additional latency for a refresh is required.

6.3.2.4 Drive strength

DQ and RWDS signal line loading, length, and impedance vary depending on each system design. Configuration register bits CR0[14:12] provide a means to adjust the DQ[7:0] and RWDS signal output impedance to customize the DQ and RWDS signal impedance to the system conditions to minimize high speed signal behaviors such as overshoot, undershoot, and ringing. The default POR or reset configuration value is 000b to select the mid point of the available output impedance options.

The impedance values shown are typical for both pull-up and pull-down drivers at typical silicon process conditions, nominal operating voltage (1.8 V or 3.0 V) and 50°C. The impedance values may vary from the typical values depending on the Process, Voltage, and Temperature (PVT) conditions. Impedance will increase with slower process, lower voltage, or higher temperature. Impedance will decrease with faster process, higher voltage, or lower temperature.

Each system design should evaluate the data signal integrity across the operating voltage and temperature ranges to select the best drive strength settings for the operating conditions.

6.3.2.5 Deep power-down

When the HYPERRAM™ device is not needed for system operation, it may be placed in a very low power consuming state called Deep power-down (DPD), by writing 0 to CR0[15]. When CR0[15] is cleared to 0, the device enters the DPD state within t_{DPDIN} time and all refresh operations stop. The data in RAM is lost, (becomes invalid without refresh) during DPD state. Exiting DPD requires driving CS# low then high, POR, or a reset. Only CS# and RESET# signals are monitored during DPD mode. For additional details, see **“Deep power-down”** on page 30.

Register space

6.3.3 Configuration register 1

Configuration register 1 (CR1) is used to define the refresh array size, refresh rate and hybrid sleep for the HYPERRAM™ device. Configurable characteristics include:

- Partial array refresh
- Hybrid sleep state
- Refresh rate

Table 12 Configuration register 1 (CR1) bit assignments

CR1 bit	Function	Setting (binary)
[15:8]	Reserved	FFh - Reserved (default) These bits should always be set to FFh
[7]	Reserved	1 - Reserved (default)
[6]	Master clock type	1 - Single-ended - CK (default) 0 - Differential - CK#, CK
[5]	Hybrid sleep	1 - Causes the device to enter Hybrid sleep state 0 - Normal operation (default)
[4:2]	Partial array refresh	000 - Full array (default) 001 - Bottom 1/2 array 010 - Bottom 1/4 array 011 - Bottom 1/8 array 100 - none 101 - Top 1/2 array 110 - Top 1/4 array 111 - Top 1/8 array
[1:0]	Distributed refresh interval (read Only)	10 - 1μs t _{CSM} (Industrial plus temperature range devices) 11 - Reserved 00 - Reserved 01 - 4μs t _{CSM} (Industrial temperature range devices)

6.3.3.1 Master clock type

Two clock types, namely single ended and differential, are supported. CR1[6] selects which type to use.

- In the single ended clock mode (by default), CK# input is not enabled; hence it may be left either floating or biased to HIGH or LOW.
- In the differential clock mode (when enabled), the CK# input can't be left floating. It must be either driven by the host, or biased to HIGH or LOW.

6.3.3.2 Partial array refresh

The partial array refresh configuration restricts the refresh operation in HYPERRAM™ to a portion of the memory array specified by CR1[5:3]. This reduces the standby current. The default configuration refreshes the whole array.

6.3.3.3 Hybrid sleep (HS)

When the HYPERRAM™ is not needed for system operation but data in the device needs to be retained, it may be placed in hybrid sleep state to save more power. Enter Hybrid sleep state by writing 1 to CR1[5]. Bringing CS# low will cause the device to exit HS state and set CR1[5] to 0. Also, POR, or a hardware reset will cause the device to exit hybrid sleep state. Note that a POR or a hardware reset disables refresh where the memory core data can potentially get lost.

6.3.3.4 Distributed refresh interval

The DRAM array requires periodic refresh of all bits in the array. This can be done by the host system by reading or writing a location in each row within a specified time limit. The read or write access copies a row of bits to an internal buffer. At the end of the access the bits in the buffer are written back to the row in memory, thereby recharging (refreshing) the bits in the row of DRAM memory cells.

HYPERRAM™ devices include self-refresh logic that will refresh rows automatically. The automatic refresh of a row can only be done when the memory is not being actively read or written by the host system. The refresh logic waits for the end of any active read or write before doing a refresh, if a refresh is needed at that time. If a new read or write begins before the refresh is completed, the memory will drive RWDS high during the CA period to indicate that an additional initial latency time is required at the start of the new access in order to allow the refresh operation to complete before starting the new access.

The required refresh interval for the entire memory array varies with temperature as shown in [Table 13](#). This is the time within which all rows must be refreshed. Refresh of all rows could be done as a single batch of accesses at the beginning of each interval, in groups (burst refresh) of several rows at a time, spread throughout each interval, or as single row refreshes evenly distributed throughout the interval. The self-refresh logic distributes single row refresh operations throughout the interval so that the memory is not busy doing a burst of refresh operations for a long period, such that the burst refresh would delay host access for a long period.

Table 13 Array refresh interval per temperature

Device temperature (°C)	Array refresh interval (ms)	Array rows	Recommended t_{CSM} (μs)
85	64	8192	4
105	16	8192	1

The distributed refresh method requires that the host does not do burst transactions that are so long as to prevent the memory from doing the distributed refreshes when they are needed. This sets an upper limit on the length of read and write transactions so that the refresh logic can insert a refresh between transactions. This limit is called the CS# low maximum time (t_{CSM}). The t_{CSM} value is determined by the array refresh interval divided by the number of rows in the array, then reducing this calculation by half to ensure that a distributed refresh interval cannot be entirely missed by a maximum length host access starting immediately before a distributed refresh is needed. Because t_{CSM} is set to half the required distributed refresh interval, any series of maximum length host accesses that delay refresh operations will catch up on refresh operations at twice the rate required by the refresh interval divided by the number of rows.

The host system is required to respect the t_{CSM} value by ending each transaction before violating t_{CSM} . This can be done by host memory controller logic splitting long transactions when reaching the t_{CSM} limit, or by host system hardware or software not performing a single read or write transaction that would be longer than t_{CSM} .

As noted in [Table 13](#), the array refresh interval is longer at lower temperatures such that t_{CSM} could be increased to allow longer transactions. The host system can either use the t_{CSM} value from the table for the maximum operating temperature or, may determine it dynamically by reading the read only CR1[1:0] bits in order to set the distributed refresh interval prior to every access.

7 Interface states

Table 14 describes the required value of each signal for each interface state.

Table 14 Interface states

Interface state	V_{CC} / V_{CCQ}	CS#	CK, CK#	DQ7-DQ0	RWDS	RESET#
Power-off	$< V_{LKO}$	X	X	High-Z	High-Z	X
Power-on (cold) reset	$\geq V_{CC} / V_{CCQ} \text{ min}$	X	X	High-Z	High-Z	X
Hardware (warm) reset	$\geq V_{CC} / V_{CCQ} \text{ min}$	X	X	High-Z	High-Z	L
Interface standby	$\geq V_{CC} / V_{CCQ} \text{ min}$	H	X	High-Z	High-Z	H
CA	$\geq V_{CC} / V_{CCQ} \text{ min}$	L	T	Master output valid	Y	H
Read initial access latency (data bus turn around period)	$\geq V_{CC} / V_{CCQ} \text{ min}$	L	T	High-Z	L	H
Write initial access latency (RWDS turn around period)	$\geq V_{CC} / V_{CCQ} \text{ min}$	L	T	High-Z	High-Z	H
Read data transfer	$\geq V_{CC} / V_{CCQ} \text{ min}$	L	T	Slave output valid	Slave output valid Z or T	H
Write data transfer with initial latency	$\geq V_{CC} / V_{CCQ} \text{ min}$	L	T	Master output valid	Master output valid X or T	H
Write data transfer without initial latency ^[40]	$\geq V_{CC} / V_{CCQ} \text{ min}$	L	T	Master output valid	Slave output L or High-Z	H
Active clock stop ^[41]	$\geq V_{CC} / V_{CCQ} \text{ min}$	L	Idle	Master or slave output valid or High-Z	Y	H
Deep power-down ^[41]	$\geq V_{CC} / V_{CCQ} \text{ min}$	H	X or T	High-Z	High-Z	H
Hybrid sleep ^[41]	$\geq V_{CC} / V_{CCQ} \text{ min}$	H	X or T	High-Z	High-Z	H

Legend

L = V_{IL} , H = V_{IH}

X = either V_{IL} or V_{IH}

Y = either V_{IL} or V_{IH} or V_{OL} or V_{OH}

Z = either V_{OL} or V_{OH}

L/H = rising edge

H/L = falling edge

T = Toggling during information transfer

Idle = CK is low and CK# is high level

Valid = all bus signals have stable L or H

Notes

40. Writes without initial latency (with zero initial latency), do not have a turn around period for RWDS. The HYPERRAM™ device will always drive RWDS during the CA period to indicate whether extended latency is required. Since master write data immediately follows the CA period the HYPERRAM™ device may continue to drive RWDS low or may take RWDS to High-Z. The master must not drive RWDS during Writes with zero latency. Writes with zero latency do not use RWDS as a data mask function. All bytes of write data are written (full word writes).

41. Active clock stop is described in “Active clock stop” on page 29, DPD is described in “Deep power-down” on page 30, and Hybrid sleep is described in “Hybrid sleep” on page 29.

8 Power conservation modes

8.1 Interface standby

Standby is the default, low power, state for the interface while the device is not selected by the host for data transfer (CS# = High). All inputs, and outputs other than CS# and RESET# are ignored in this state.

8.2 Active clock stop

The Active clock stop state reduces device interface energy consumption to the I_{CC6} level during the data transfer portion of a read or write operation. The device automatically enables this state when clock remains stable for $t_{ACC} + 30$ ns. While in Active clock stop state, read data is latched and always driven onto the data bus. I_{CC6} shown in “DC characteristics” on page 33.

Active clock stop state helps reduce current consumption when the host system clock has stopped to pause the data transfer. Even though CS# may be low throughout these extended data transfer cycles, the memory device host interface will go into the Active clock stop current level at $t_{ACC} + 30$ ns. This allows the device to transition into a lower current state if the data transfer is stalled. Active read or write current will resume once the data transfer is restarted with a toggling clock. The Active clock stop state must not be used in violation of the t_{CSM} limit. CS# must go high before t_{CSM} is violated. Clock can be stopped during any portion of the active transaction as long as it is in the low state. Note that it is recommended to avoid stopping the clock during register access.

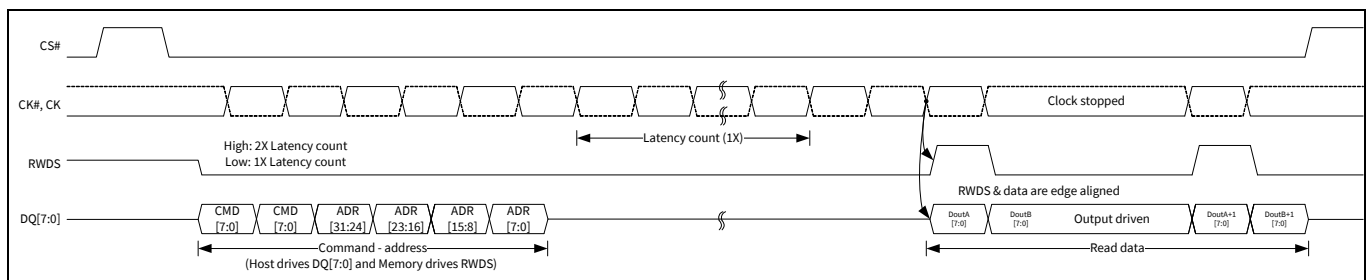

Figure 14 Active clock stop during read transaction (DDR)^[42]

8.3 Hybrid sleep

In the Hybrid sleep (HS) state, the current consumption is reduced (i_{HS}). HS state is entered by writing a 1 to CR1[5]. The device reduces power within t_{HSIN} time. The data in Memory space and register space is retained during HS state. Bringing CS# low will cause the device to exit HS state and set CR1[5] to 0. Also, POR, or a hardware reset will cause the device to exit Hybrid sleep state. Note that a POR or a hardware reset disables refresh where the memory core data can potentially get lost. Returning to Standby state requires t_{EXITHS} time. Following the exit from HS due to any of these events, the device is in the same state as entering Hybrid sleep.

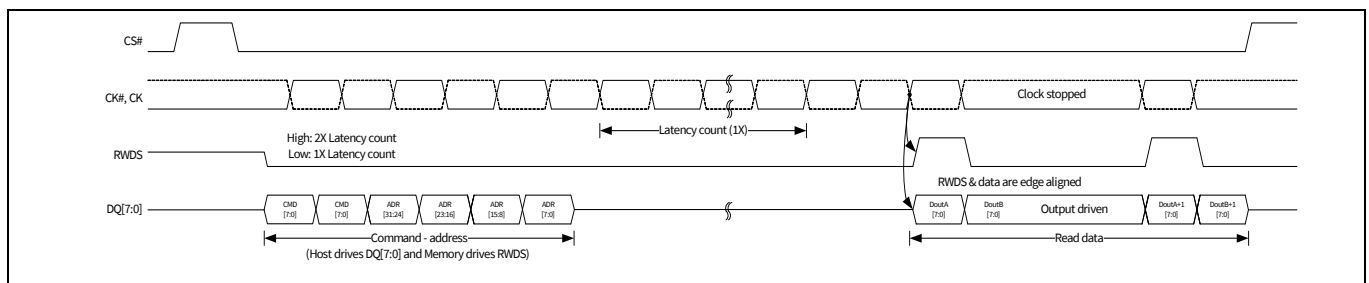

Figure 15 Enter HS transaction

Note

42. RWDS is low during the CA cycles. In this Read transaction, there is a single initial latency count for read data access because, this read transaction does not begin at a time when additional latency is required by the slave.

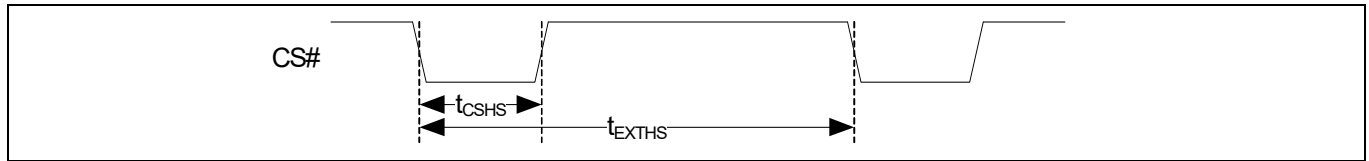

Figure 16 Exit HS transaction

Table 15 Hybrid sleep timing parameters

Parameter	Description	Min	Max	Unit
t_{HSIN}	Hybrid sleep CR1[5] = 1 register write to HS power level	–	3	μs
t_{CSHS}	CS# pulse width to Exit HS	60	3000	ns
t_{EXTHS}	CS# exit hybrid sleep to standby wakeup time	–	100	μs

8.4 Deep power-down

In the Deep power-down (DPD) state, current consumption is driven to the lowest possible level (I_{DPD}). DPD state is entered by writing a 0 to CR0[15]. The device reduces power within t_{DPDIN} time and all refresh operations stop. The data in Memory space is lost, (becomes invalid without refresh) during DPD state. Driving CS# low then high will cause the device to exit DPD state. Also, POR, or a hardware reset will cause the device to exit DPD state. Returning to Standby state requires t_{EXTDPD} time. Returning to standby state following a POR requires t_{VCS} time, as with any other POR. Following the exit from DPD due to any of these events, the device is in the same state as following POR.

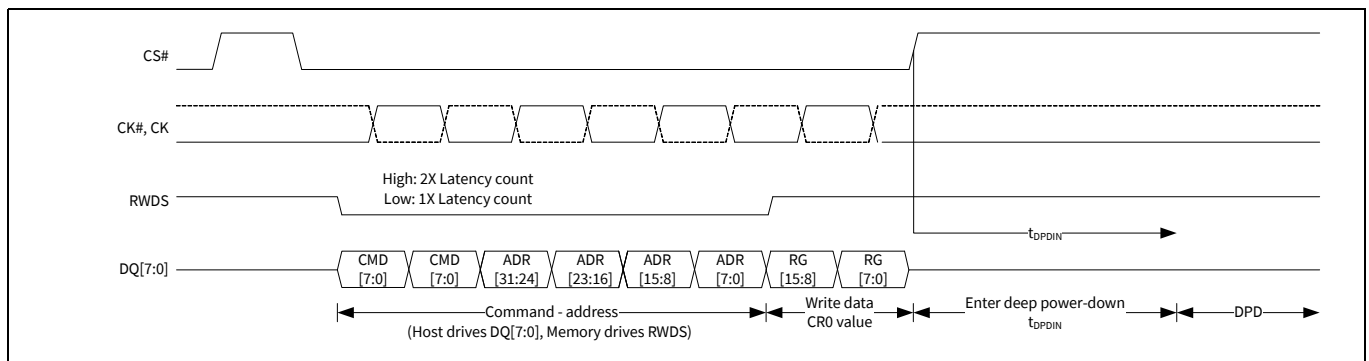

Figure 17 Enter DPD transaction

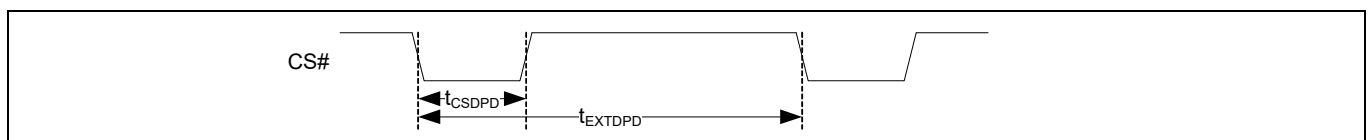

Figure 18 Exit DPD transaction

Table 16 Deep power-down timing parameters

Parameter	Description	Min	Max	Unit
t_{DPDIN}	Deep power-down CR0[15] = 0 register write to DPD power level	–	3	μs
t_{CSDPD}	CS# pulse width to exit DPD	200	3000	ns
t_{EXTPDP}	CS# exit deep power-down to standby wakeup time	–	150	μs

9 Electrical specifications

9.1 Absolute maximum ratings^[45]

Storage temperature plastic packages -65 °C to +150 °C

Ambient temperature with power applied -65 °C to +115 °C

Voltage with respect to ground

All signals^[43] -0.5V to + (V_{CC} + 0.5 V)

Output short circuit current^[44] 100 mA

V_{CC}, V_{CCQ} -0.5 V to +4.0 V

Electrostatic discharge voltage:

Human body model (JEDEC Std JESD22-A114-B) 2000 V

Charged device model (JEDEC Std JESD22-C101-A) .. 500 V

9.2 Input signal overshoot

During DC conditions, input or I/O signals should remain equal to or between V_{SS} and V_{CC}. During voltage transitions, inputs or I/Os may negative overshoot V_{SS} to -1.0 V or positive overshoot to V_{CC} +1.0 V, for periods up to 20 ns.

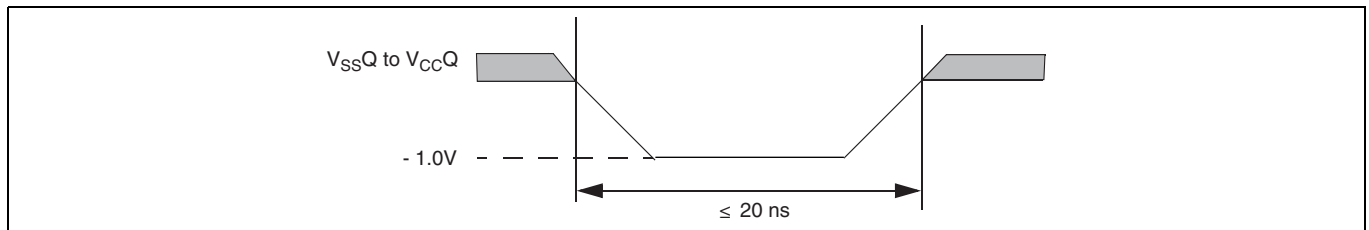

Figure 19 Maximum negative overshoot waveform

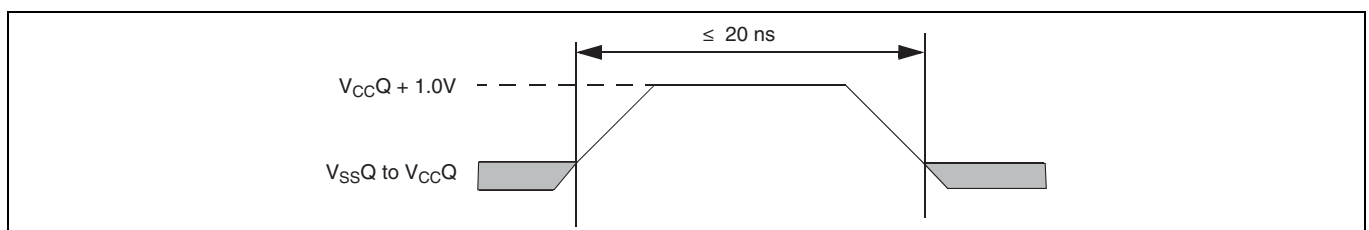

Figure 20 Maximum positive overshoot waveform

Notes

43. Minimum DC voltage on input or I/O signal is -1.0 V. During voltage transitions, input or I/O signals may undershoot V_{SS} to -1.0 V for periods of up to 20 ns. See **Figure 19**. Maximum DC voltage on input or I/O signals is V_{CC} +1.0 V. During voltage transitions, input or I/O signals may overshoot to V_{CC} +1.0 V for periods up to 20 ns. See **Figure 20**.
44. No more than one output may be shorted to ground at a time. Duration of the short circuit should not be greater than one second.
45. Stresses above those listed under “**Absolute maximum ratings**[45]” on page 31 may cause permanent damage to the device. This is a stress rating only; functional operation of the device at these or any other conditions above those indicated in the operational sections of this data sheet is not implied. Exposure of the device to absolute maximum rating conditions for extended periods may affect device reliability.

Electrical specifications

9.3 Latch-up characteristics

Table 17 Latch-up specification^[46]

Description	Min	Max	Unit
Input voltage with respect to V_{SSQ} on all input only connections	-1.0	$V_{CCQ} + 1.0$	V
Input voltage with respect to V_{SSQ} on all I/O connections	-1.0	$V_{CCQ} + 1.0$	V
V_{CCQ} current	-100	+100	mA

9.4 Operating ranges

Operating ranges define those limits between which the functionality of the device is guaranteed.

9.4.1 Temperature ranges

Parameter	Symbol	Device	Spec		Unit
			Min	Max	
Ambient temperature	T_A	Industrial (I)	-40	85	°C
		Industrial plus (V)	-40	105	°C
		Automotive, AEC-Q100 grade 3 (A)	-40	85	°C
		Automotive, AEC-Q100 grade 2 (B)	-40	105	°C

9.4.2 Power supply voltages

Description	Min	Max	Unit
1.8 V V_{CC} power supply	1.7	2.0	V
3.0 V V_{CC} power supply	2.7	3.60	V

Note

46. Excludes power supplies V_{CC}/V_{CCQ} . Test conditions: $V_{CC} = V_{CCQ}$, one connection at a time tested, connections not being tested are at V_{SS} .

9.5 DC characteristics

Table 18 DC characteristics (CMOS compatible)

Parameter	Description	Test conditions	64 Mb			Unit
			Min	Typ ^[47]	Max	
I _{LI1}	Input leakage current 3.0 V device reset signal high Only	V _{IN} = V _{SS} to V _{CC} , V _{CC} = V _{CC} max	–	–	–2	μA
I _{LI2}	Input leakage current 1.8 V device reset signal high only	V _{IN} = V _{SS} to V _{CC} , V _{CC} = V _{CC} max	–	–	–2	μA
I _{LI3}	Input leakage current 3.0 V device reset signal low only ^[48]	V _{IN} = V _{SS} to V _{CC} , V _{CC} = V _{CC} max	–	–	15	μA
I _{LI4}	Input leakage current 1.8 V device reset signal low only ^[48]	V _{IN} = V _{SS} to V _{CC} , V _{CC} = V _{CC} max	–	–	15	μA
I _{CC1}	V _{CC} active read current	CS# = V _{SS} , @200 MHz, V _{CC} = 2.0V	–	15	25	mA
		CS# = V _{SS} , @166 MHz, V _{CC} = 3.6V	–	15	28	mA
		CS# = V _{SS} , @200 MHz, V _{CC} = 3.6V	–	15	30	mA
I _{CC2}	V _{CC} active write current	CS# = V _{SS} , @200 MHz, V _{CC} = 2.0V	–	15	25	mA
		CS# = V _{SS} , @166 MHz, V _{CC} = 3.6V	–	15	28	mA
		CS# = V _{SS} , @200 MHz, V _{CC} = 3.6V	–	15	30	mA
I _{CC4I}	V _{CC} standby current (–40 °C to +85 °C)	CS# = V _{CC} , V _{CC} = 2.0 V; Full array	–	80	220	μA
		CS# = V _{CC} , V _{CC} = 2.0 V; Bottom 1/2 array	–	–	200	μA
		CS# = V _{CC} , V _{CC} = 2.0 V; Bottom 1/4 array	–	–	180	μA
		CS# = V _{CC} , V _{CC} = 2.0 V; Bottom 1/8 array	–	–	170	μA
		CS# = V _{CC} , V _{CC} = 2.0 V; Top 1/2 array	–	–	200	μA
		CS# = V _{CC} , V _{CC} = 2.0 V; Top 1/4 array	–	–	180	μA
		CS# = V _{CC} , V _{CC} = 2.0 V; Top 1/8 array	–	–	170	μA
		CS# = V _{CC} , V _{CC} = 3.6 V; Full array	–	90	250	μA
		CS# = V _{CC} , V _{CC} = 3.6 V; Bottom 1/2 array	–	–	230	μA
		CS# = V _{CC} , V _{CC} = 3.6 V; Bottom 1/4 array	–	–	200	μA

Notes

47. Not 100% tested.

48. RESET# low initiates exits from DPD and HS states and initiates the draw of I_{CC5} reset current, making I_{LI} during RESET# low insignificant.

Electrical specifications

Table 18 DC characteristics (CMOS compatible) (Continued)

Parameter	Description	Test conditions	64 Mb			Unit
			Min	Typ ^[47]	Max	
I _{CC4I}	V _{CC} standby current (-40 °C to +85 °C)	CS# = V _{CC} , V _{CC} = 3.6 V; Bottom 1/8 array	–	–	190	μA
		CS# = V _{CC} , V _{CC} = 3.6 V; Top 1/2 array	–	–	230	μA
		CS# = V _{CC} , V _{CC} = 3.6 V; Top 1/4 array	–	–	200	μA
		CS# = V _{CC} , V _{CC} = 3.6 V; Top 1/8 array	–	–	190	μA
I _{CC4P}	V _{CC} standby current (-40 °C to +105 °C)	CS# = V _{CC} , V _{CC} = 2.0 V; Full array	–	80	330	μA
		CS# = V _{CC} , V _{CC} = 2.0 V; Bottom 1/2 array	–	–	300	μA
		CS# = V _{CC} , V _{CC} = 2.0 V; Bottom 1/4 array	–	–	270	μA
		CS# = V _{CC} , V _{CC} = 2.0 V; Bottom 1/8 array	–	–	250	μA
		CS# = V _{CC} , V _{CC} = 2.0 V; Top 1/2 array	–	–	300	μA
		CS# = V _{CC} , V _{CC} = 2.0 V; Top 1/4 array	–	–	270	μA
		CS# = V _{CC} , V _{CC} = 2.0 V; Top 1/8 array	–	–	250	μA
		CS# = V _{CC} , V _{CC} = 3.6 V; Full array	–	90	360	μA
		CS# = V _{CC} , V _{CC} = 3.6 V; Bottom 1/2 array	–	–	330	μA
		CS# = V _{CC} , V _{CC} = 3.6 V; Bottom 1/4 array	–	–	290	μA
		CS# = V _{CC} , V _{CC} = 3.6 V; Bottom 1/8 array	–	–	270	μA
		CS# = V _{CC} , V _{CC} = 3.6 V; Top 1/2 array	–	–	330	μA
		CS# = V _{CC} , V _{CC} = 3.6 V; Top 1/4 array	–	–	290	μA
		CS# = V _{CC} , V _{CC} = 3.6 V; Top 1/8 array	–	–	270	μA
I _{CC5}	Reset current	CS# = V _{CC} , RESET# = V _{SS} , V _{CC} = V _{CC} max	–	–	1	mA
I _{CC6I}	Active clock stop current (-40 °C to +85 °C)	CS# = V _{SS} , RESET# = V _{CC} , V _{CC} = V _{CC} max	–	5	8	mA
I _{CC6IP}	Active clock stop current (-40 °C to +105 °C)	CS# = V _{SS} , RESET# = V _{CC} , V _{CC} = V _{CC} max	–	8	12	mA
I _{CC7}	V _{CC} current during power up ^[47]	CS# = V _{CC} , V _{CC} = V _{CC} max, V _{CC} = V _{CCQ} = 2.0 V or 3.6 V	–	–	35	mA

Notes

47. Not 100% tested.

48. RESET# low initiates exits from DPD and HS states and initiates the draw of I_{CC5} reset current, making I_{L1} during RESET# low insignificant.

Electrical specifications

Table 18 DC characteristics (CMOS compatible) (Continued)

Parameter	Description	Test conditions	64 Mb			Unit
			Min	Typ ^[47]	Max	
IDPD ^[48]	Deep power-down current 3.0 V (-40 °C to +85 °C)	CS# = V _{CC} , V _{CC} = 3.6 V	–	–	12	μA
	Deep power-down current 1.8 V (-40 °C to +85 °C)	CS# = V _{CC} , V _{CC} = 2.0 V	–	–	10	μA
	Deep power-down current 3.0 V (-40 °C to +105 °C)	CS# = V _{CC} , V _{CC} = 3.6 V	–	–	15	μA
	Deep power-down current 1.8 V (-40 °C to +105 °C)	CS# = V _{CC} , V _{CC} = 2.0 V	–	–	12	μA
I _{HS} ^[48]	Hybrid sleep current 1.8 V (-40 °C to +85 °C)	CS# = V _{CC} , V _{CC} = 2.0 V; Full array	–	25	200	μA
		CS# = V _{CC} , V _{CC} = 2.0 V; Bottom 1/2 array	–	–	170	μA
		CS# = V _{CC} , V _{CC} = 2.0 V; Bottom 1/4 array	–	–	150	μA
		CS# = V _{CC} , V _{CC} = 2.0 V; Bottom 1/8 array	–	–	140	μA
		CS# = V _{CC} , V _{CC} = 2.0 V; Top 1/2 array	–	–	170	μA
		CS# = V _{CC} , V _{CC} = 2.0 V; Top 1/4 array	–	–	150	μA
		CS# = V _{CC} , V _{CC} = 2.0 V; Top 1/8 array	–	–	140	μA
	Hybrid sleep current 3.0 V (-40 °C to +85 °C)	CS# = V _{CC} , V _{CC} = 3.6 V; Full array	–	35	230	μA
		CS# = V _{CC} , V _{CC} = 3.6 V; Bottom 1/2 array	–	–	200	μA
		CS# = V _{CC} , V _{CC} = 3.6 V; Bottom 1/4 array	–	–	170	μA
		CS# = V _{CC} , V _{CC} = 3.6 V; Bottom 1/8 array	–	–	150	μA
		CS# = V _{CC} , V _{CC} = 3.6 V; Top 1/2 array	–	–	200	μA
		CS# = V _{CC} , V _{CC} = 3.6 V; Top 1/4 array	–	–	170	μA
CS# = V _{CC} , V _{CC} = 3.6 V; Top 1/8 array		–	–	150	μA	
Hybrid sleep current 1.8 V (-40 °C to +105 °C)	CS# = V _{CC} , V _{CC} = 2.0 V; Full array	–	25	300	μA	
	CS# = V _{CC} , V _{CC} = 2.0 V; Bottom 1/2 array	–	–	270	μA	
	CS# = V _{CC} , V _{CC} = 2.0 V; Bottom 1/4 array	–	–	240	μA	

Notes

47. Not 100% tested.

48. RESET# low initiates exits from DPD and HS states and initiates the draw of I_{CC5} reset current, making I_{L1} during RESET# low insignificant.

Electrical specifications

Table 18 DC characteristics (CMOS compatible) (Continued)

Parameter	Description	Test conditions	64 Mb			Unit	
			Min	Typ ^[47]	Max		
$I_{HS}^{[48]}$	Hybrid sleep current 1.8 V (-40 °C to +105 °C)	CS# = V _{CC} , V _{CC} = 2.0 V; Bottom 1/8 array	–	–	210	μA	
		CS# = V _{CC} , V _{CC} = 2.0 V; Top 1/2 array	–	–	270	μA	
		CS# = V _{CC} , V _{CC} = 2.0 V; Top 1/4 array	–	–	240	μA	
		CS# = V _{CC} , V _{CC} = 2.0 V; Top 1/8 array	–	–	210	μA	
	Hybrid sleep current 3.0 V (-40 °C to +105 °C)	CS# = V _{CC} , V _{CC} = 3.6 V; Full array	–	35	330	μA	
		CS# = V _{CC} , V _{CC} = 3.6 V; Bottom 1/2 array	–	–	300	μA	
		CS# = V _{CC} , V _{CC} = 3.6 V; Bottom 1/4 array	–	–	260	μA	
		CS# = V _{CC} , V _{CC} = 3.6 V; Bottom 1/8 array	–	–	250	μA	
		CS# = V _{CC} , V _{CC} = 3.6 V; Top 1/2 array	–	–	300	μA	
		CS# = V _{CC} , V _{CC} = 3.6 V; Top 1/4 array	–	–	260	μA	
		CS# = V _{CC} , V _{CC} = 3.6 V; Top 1/8 array	–	–	250	μA	
	V _{IL}	Input low voltage	–	-0.15 x V _{CCQ}	–	0.30 x V _{CCQ}	V
	V _{IH}	Input high voltage	–	0.70 x V _{CCQ}	–	1.15 x V _{CCQ}	V
	V _{OL}	Output low voltage	I _{OL} = 100 μA for DQ[7:0]	–	–	0.20	V
V _{OH}	Output high voltage	I _{OH} = 100 μA for DQ[7:0]	V _{CCQ} -0.20	–	–	V	

Notes

47. Not 100% tested.

48. RESET# low initiates exits from DPD and HS states and initiates the draw of I_{CC5} reset current, making I_{LI} during RESET# low insignificant.

Electrical specifications

9.5.1 Capacitance characteristics

Table 19 1.8 V capacitive characteristics^[49-51]

Description	Parameter	64 Mb	Unit
		Max	
Input capacitance (CK, CK#, CS#)	CI	3.0	pF
Delta input capacitance (CK, CK#)	CID	0.25	pF
Output capacitance (RWDS)	CO	3.0	pF
I/O capacitance (DQx)	CIO	3.0	pF
I/O capacitance delta (DQx)	CIOD	0.25	pF

Table 20 3.0 V capacitive characteristics^[49-51]

Description	Parameter	64 Mb	Unit
		Max	
Input capacitance (CK, CK#, CS#)	CI	3.0	pF
Delta input capacitance (CK, CK#)	CID	0.25	pF
Output capacitance (RWDS)	CO	3.0	pF
IO capacitance (DQx)	CIO	3.0	pF
IO capacitance delta (DQx)	CIOD	0.25	pF

Table 21 Thermal resistance

Parameter ^[52]	Description	Test conditions	24-ball FBGA package	Unit
θ_{JA}	Thermal resistance (junction to ambient)	Test conditions follow standard test methods and procedures for measuring thermal impedance, per EIA/JESD51.	66.7	°C/W
θ_{JC}	Thermal resistance (junction to case)		37	°C/W

Notes

49. These values are guaranteed by design and are tested on a sample basis only.
50. Contact capacitance is measured according to JEP147 procedure for measuring capacitance using a vector network analyzer. V_{CC} , V_{CCQ} are applied and all other signals (except the signal under test) floating. DQ's should be in the high impedance state.
51. Note that the capacitance values for the CK, CK#, RWDS and DQx signals must have similar capacitance values to allow for signal propagation time matching in the system. The capacitance value for CS# is not as critical because there are no critical timings between CS# going active (low) and data being presented on the DQs bus.
52. This parameter is guaranteed by characterization; not tested in production.

9.6 Power-up initialization

HYPERRAM™ products include an on-chip voltage sensor used to launch the power-up initialization process. V_{CC} and V_{CCQ} must be applied simultaneously. When the power supply reaches a stable level at or above $V_{CC}(\text{min})$, the device will require t_{VCS} time to complete its self-initialization process.

The device must not be selected during power-up. CS# must follow the voltage applied on V_{CCQ} until $V_{CC}(\text{min})$ is reached during power-up, and then CS# must remain high for a further delay of t_{VCS} . A simple pull-up resistor from V_{CCQ} to Chip Select (CS#) can be used to insure safe and proper power-up.

If RESET# is low during power up, the device delays start of the t_{VCS} period until RESET# is high. The t_{VCS} period is used primarily to perform refresh operations on the DRAM array to initialize it.

When initialization is complete, the device is ready for normal operation.

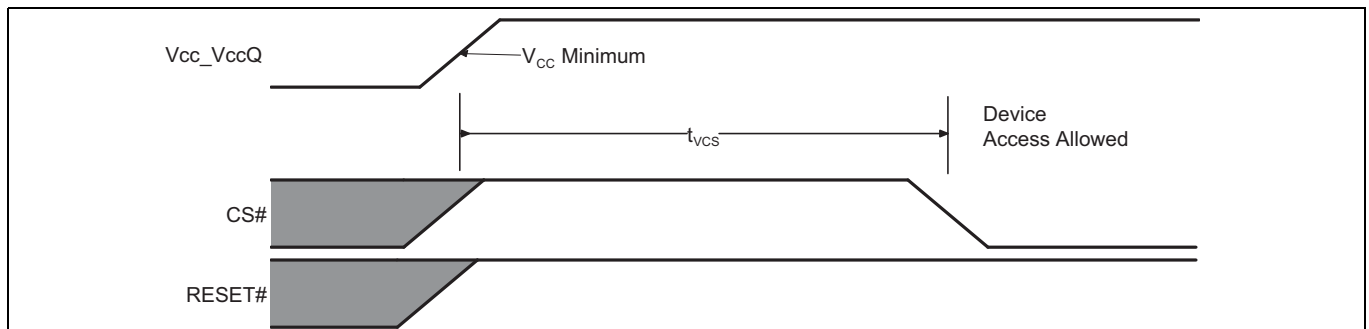

Figure 21 Power-up with RESET# high

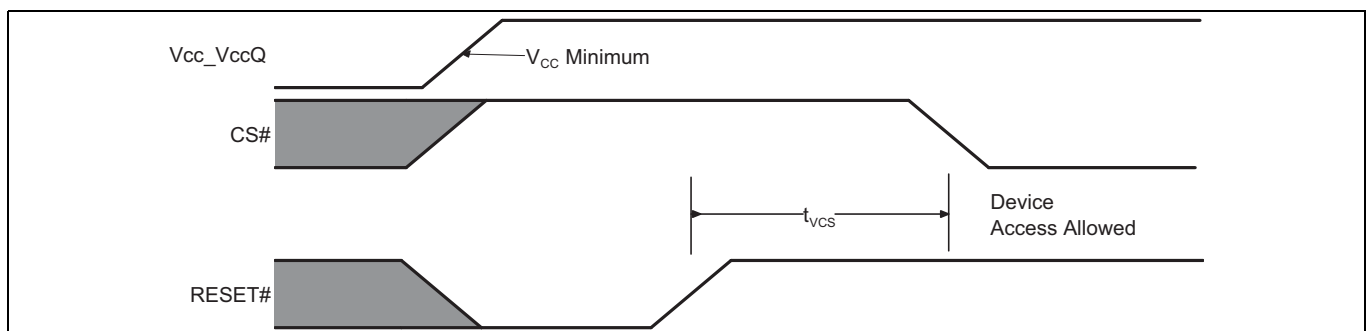

Figure 22 Power-up with RESET# low

Table 22 Power-up and reset parameters^[53-55]

Parameter	Description	Min	Max	Unit
V_{CC}	1.8 V V_{CC} Power Supply	1.7	2.0	V
V_{CC}	3.0 V V_{CC} Power Supply	2.7	3.6	V
t_{VCS}	V_{CC} and $V_{CCQ} \geq$ minimum and RESET# high to first access	-	150	μs

Notes

- 53. Bus transactions (read and write) are not allowed during the power-up reset time (t_{VCS}).
- 54. V_{CCQ} must be the same voltage as V_{CC} .
- 55. V_{CC} ramp rate may be non-linear.

9.7 Power-down

HYPERRAM™ devices are considered to be powered-off when the array power supply (V_{CC}) drops below the V_{CC} Lock-Out voltage (V_{LKO}). During a power supply transition down to the V_{SS} level, V_{CCQ} should remain less than or equal to V_{CC} . At the V_{LKO} level, the HYPERRAM™ device will have lost configuration or array data.

V_{CC} must always be greater than or equal to V_{CCQ} ($V_{CC} \geq V_{CCQ}$).

During power-down or voltage drops below V_{LKO} , the array power supply voltages must also drop below V_{CC} Reset (V_{RST}) for a power-down period (t_{PD}) for the part to initialize correctly when the power supply again rises to V_{CC} minimum. See [Figure 23](#).

If during a voltage drop the V_{CC} stays above V_{LKO} the part will stay initialized and will work correctly when V_{CC} is again above V_{CC} minimum. If V_{CC} does not go below and remain below V_{RST} for greater than t_{PD} , then there is no assurance that the POR process will be performed. In this case, a hardware reset will be required ensure the HYPERBUS™ device is properly initialized.

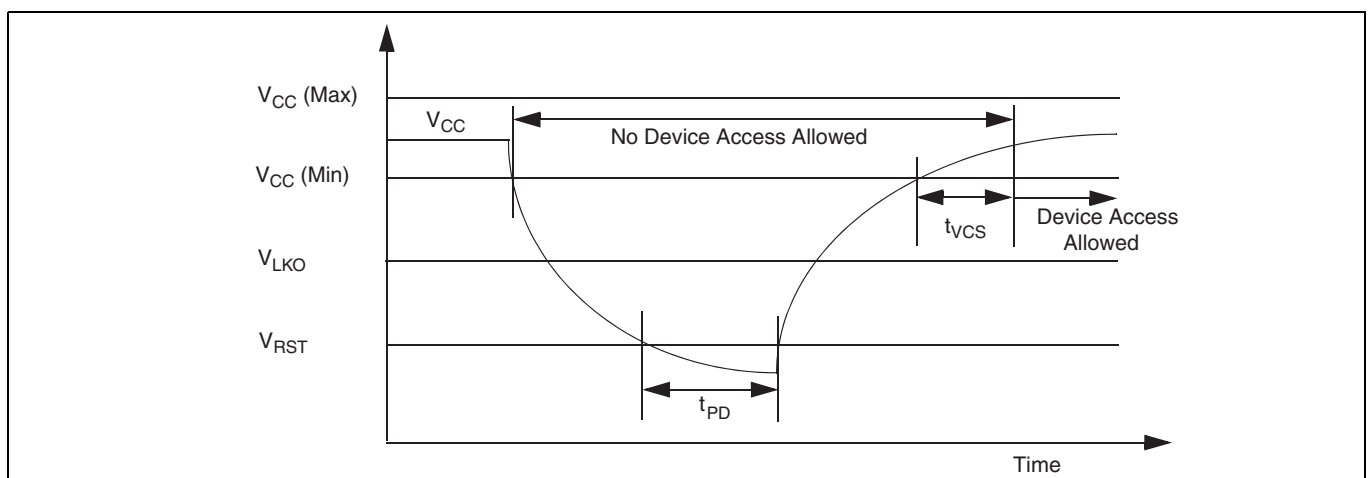

Figure 23 Power-down or voltage drop

The following section describes the HYPERRAM™ device-dependent aspects of power-down specifications.

Table 23 1.8 V power-down voltage and timing^[56]

Symbol	Parameter	Min	Max	Unit
V_{CC}	V_{CC} power supply	1.7	2.0	V
V_{LKO}	V_{CC} lock-out below which re-initialization is required	1.5	–	V
V_{RST}	V_{CC} low voltage needed to ensure initialization will occur	0.7	–	V
t_{PD}	Duration of $V_{CC} \leq V_{RST}$	50	–	μ s

Table 24 3.0 V power-down voltage and timing^[56]

Symbol	Parameter	Min	Max	Unit
V_{CC}	V_{CC} power supply	2.7	3.6	V
V_{LKO}	V_{CC} lock-out below which re-initialization is required	2.4	–	V
V_{RST}	V_{CC} low Voltage needed to ensure initialization will occur	0.7	–	V
t_{PD}	Duration of $V_{CC} \leq V_{RST}$	50	–	μ s

Note

56. V_{CC} ramp rate can be non-linear.

9.8 Hardware reset

The RESET# input provides a hardware method of returning the device to the Standby state.

During t_{RPH} the device will draw I_{CC5} current. If RESET# continues to be held low beyond t_{RPH} , the device draws CMOS standby current (I_{CC4}). While RESET# is low (during t_{RP}), and during t_{RPH} , bus transactions are not allowed.

A hardware reset will do the following:

- Cause the configuration registers to return to their default values
- Halt self-refresh operation while RESET# is low - memory array data is considered as invalid
- Force the device to exit the Hybrid sleep state
- Force the device to exit the Deep power-down state

After RESET# returns high, the self-refresh operation will resume. Because self-refresh operation is stopped during RESET# low, and the self-refresh row counter is reset to its default value, some rows may not be refreshed within the required array refresh interval per [Table 13](#). This may result in the loss of DRAM array data during or immediately following a hardware reset. The host system should assume DRAM array data is lost after a hardware reset and reload any required data.

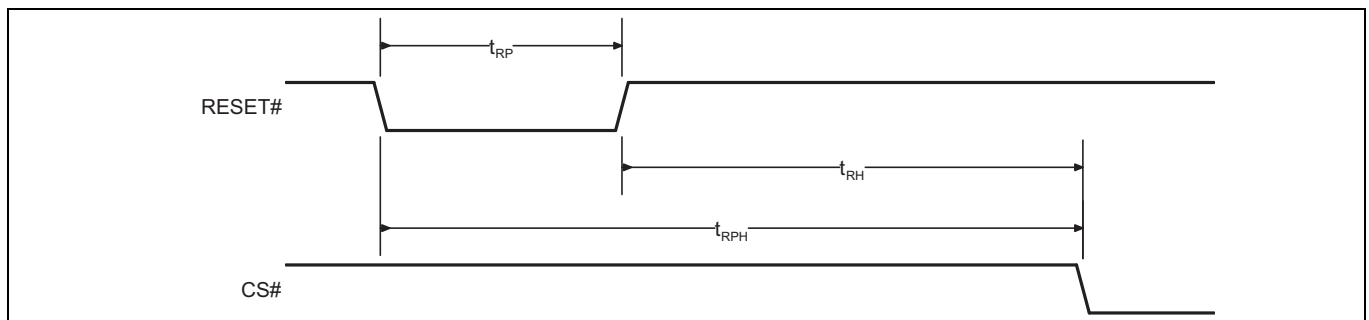

Figure 24 Hardware reset timing diagram

Table 25 Power-up and reset parameters

Parameter	Description	Min	Max	Unit
t_{RP}	RESET# pulse width	200	–	ns
t_{RH}	Time between RESET# (high) and CS# (low)	200	–	ns
t_{RPH}	RESET# low to CS# low	400	–	ns

10 Timing specifications

The following section describes HYPERRAM™ device dependent aspects of timing specifications.

10.1 Key to switching waveforms

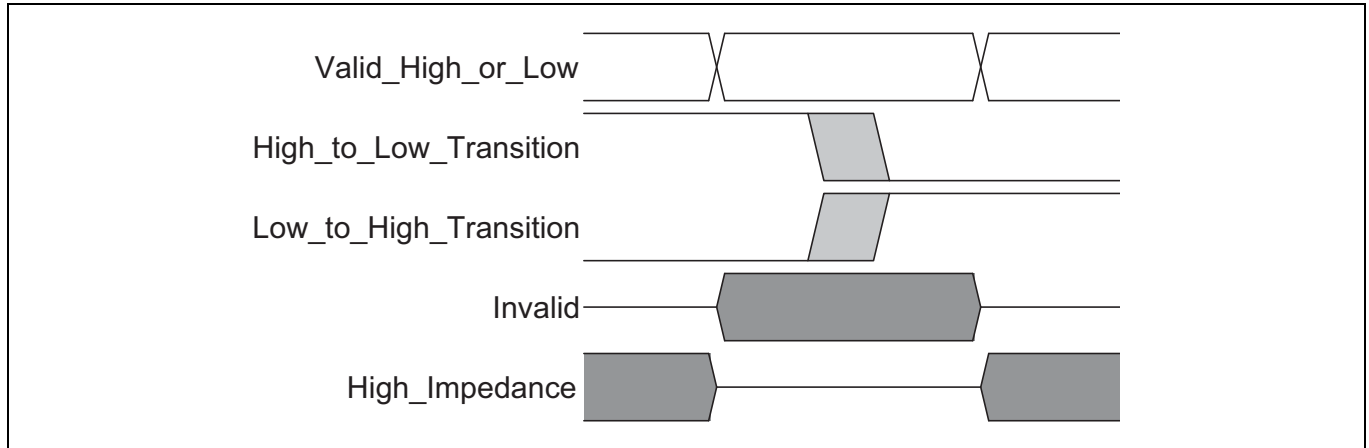

10.2 AC test conditions

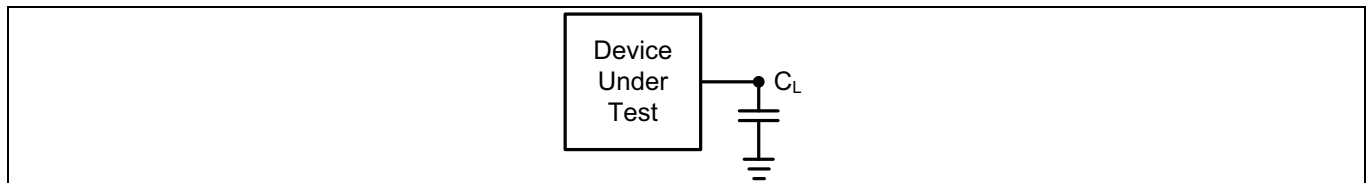

Figure 25 Test setup

Table 26 Test specification^[58]

Parameter	All speeds	Unit
Output load capacitance, C_L	15	pF
Minimum input rise and fall slew rates (1.8 V) ^[57]	1.13	V/ns
Minimum input rise and fall slew rates (3.0 V) ^[57]	2.06	V/ns
Input pulse levels	0.0- V_{CCQ}	V
Input timing measurement reference levels	$V_{CCQ}/2$	V
Output timing measurement reference levels	$V_{CCQ}/2$	V

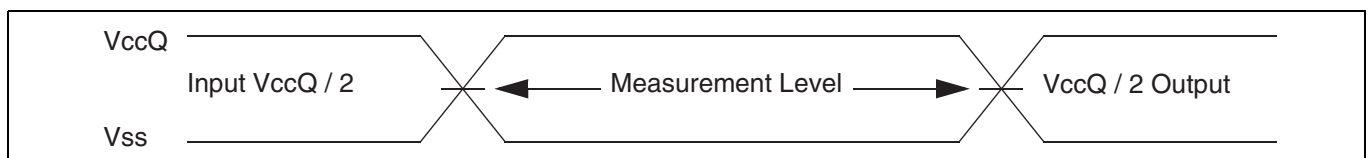

Figure 26 Input waveform and measurement levels^[59]

Notes

- 57. All AC timings assume this input slew rate.
- 58. Input and output timing is referenced to $V_{CCQ}/2$ or to the crossing of CK/CK#.
- 59. Input timings for the differential CK/CK# pair are measured from clock crossings.

10.3 Timing reference levels

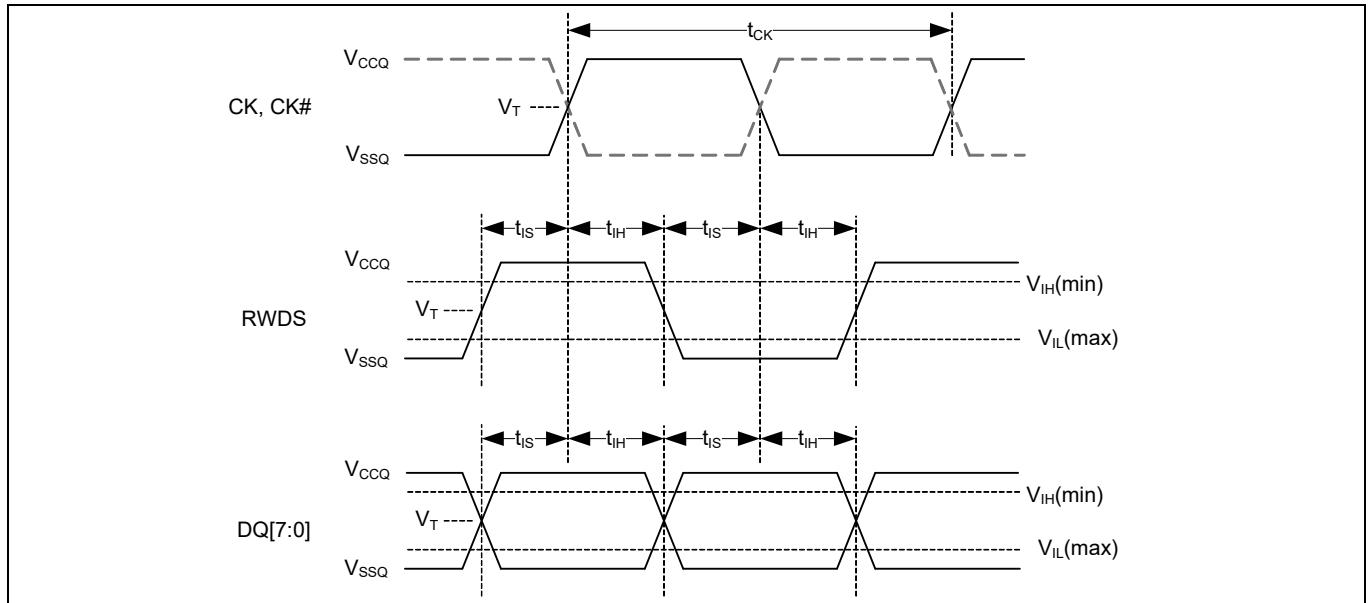

Figure 27 DDR input timing reference level

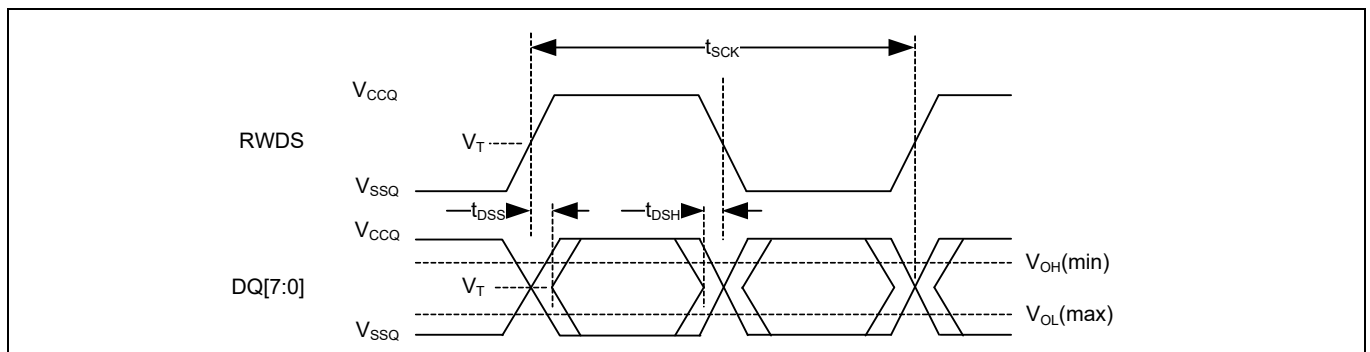

Figure 28 DDR output timing reference level

10.4 CLK characteristics

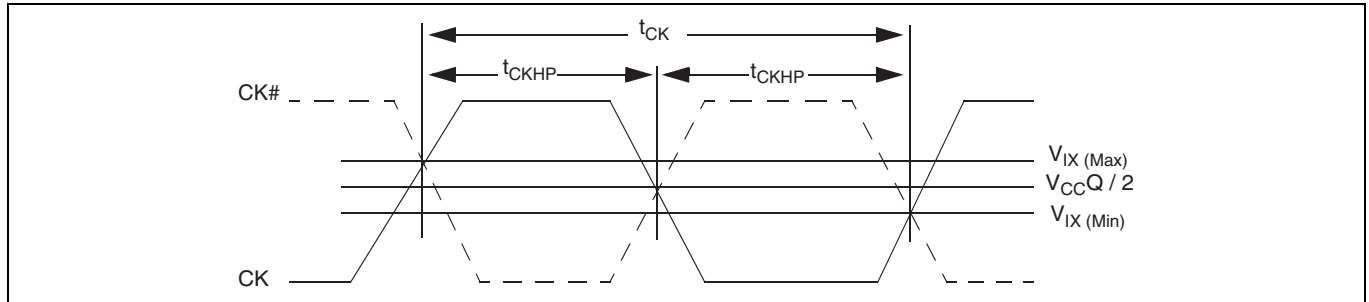

Figure 29 Clock characteristics

Table 27 Clock timings^[60-62]

Parameter	Symbol	200 MHz		166 MHz		Unit
		Min	Max	Min	Max	
CK period	t_{CK}	5	–	6	–	ns
CK half period - duty cycle	t_{CKHP}	0.45	0.55	0.45	0.55	t_{CK}
CK half period at frequency Min = 0.45 t_{CK} Min Max = 0.55 t_{CK} Min	t_{CKHP}	2.25	2.75	2.7	3.3	ns

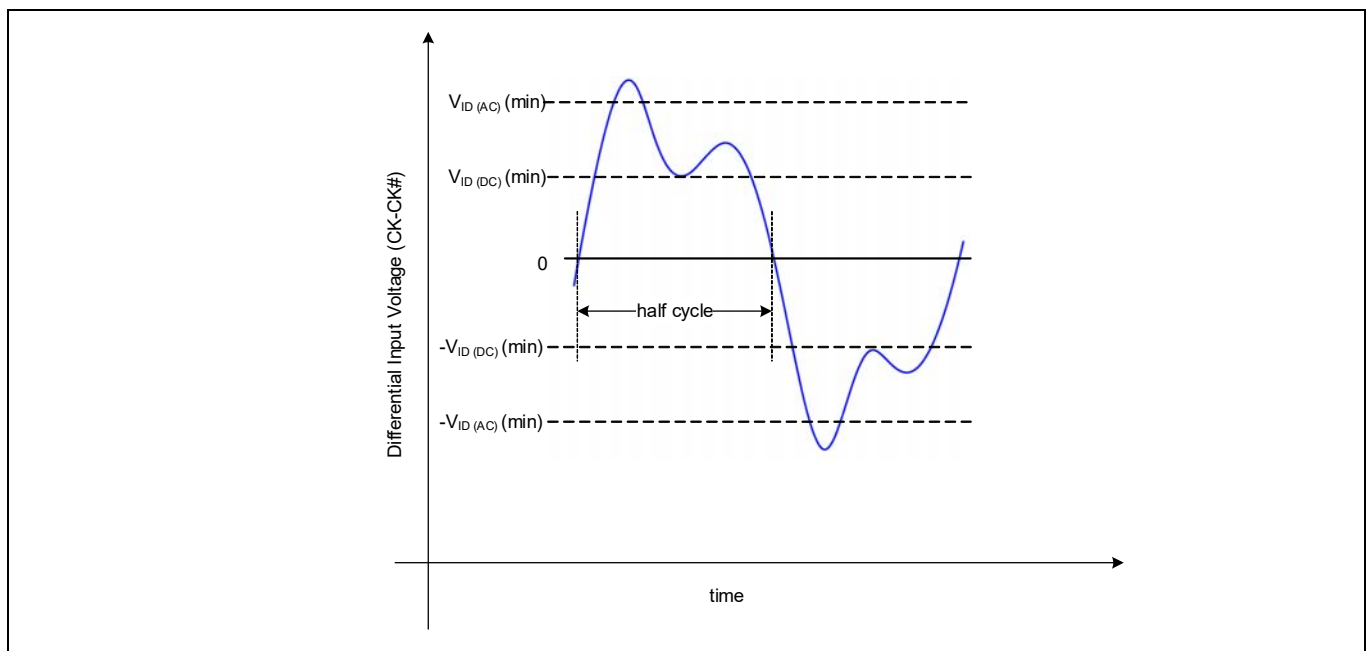

Figure 30 Differential clock (CK/CK#) input swing

Notes

- 60. Clock jitter of $\pm 5\%$ is permitted.
- 61. Minimum frequency (Maximum t_{CK}) is dependent upon maximum CS# low time (t_{CSM}), initial latency and burst length.
- 62. CK and CK# input slew rate must be ≥ 1 V/ns (2 V/ns if measured differentially).

64-Mb HYPERRAM™ self-refresh DRAM (PSRAM)
HYPERBUS™ interface, 1.8 V/3.0 V



Timing specifications

Table 28 Clock AC/DC electrical characteristics^[63, 64]

Parameter	Symbol	Min	Max	Unit
DC input voltage	V_{IN}	-0.3	$V_{CCQ} + 0.3$	V
DC input differential voltage	$V_{ID(DC)}$	$V_{CCQ} \times 0.4$	$V_{CCQ} + 0.6$	V
AC input differential voltage	$V_{ID(AC)}$	$V_{CCQ} \times 0.6$	$V_{CCQ} + 0.6$	V
AC differential crossing voltage	V_{IX}	$V_{CCQ} \times 0.4$	$V_{CCQ} \times 0.6$	V

Notes

63. V_{ID} is the magnitude of the difference between the input level on CK and the input level on CK#.

64. The value of V_{IX} is expected to equal $V_{CCQ}/2$ of the transmitting device and must track variations in the DC level of V_{CCQ} .

Timing specifications

10.5 AC characteristics

10.5.1 Read transactions

Table 29 HYPERRAM™ specific read timing parameters

Parameter	Symbol	200 MHz		166 MHz		Unit
		Min	Max	Min	Max	
Chip select high between transactions - 1.8 V	t_{CSHI}	6	–	6	–	ns
Chip select high between transactions - 3.0 V		6	–	6	–	
HYPERRAM™ read-write recovery time - 1.8 V	t_{RWR}	35	–	36	–	ns
HYPERRAM™ read-write recovery time - 3.0 V		35	–	36	–	
Chip select setup to next CK rising edge	t_{CSS}	4.0	–	3	–	ns
Data strobe valid - 1.8 V	t_{DSV}	–	5.0	–	12	ns
Data strobe valid - 3.0 V		–	6.5	–	12	
Input setup - 1.8 V	t_{IS}	0.5	–	0.6	–	ns
Input setup - 3.0 V		0.5	–	0.6	–	
Input hold - 1.8 V	t_{IH}	0.5	–	0.6	–	ns
Input hold - 3.0 V		0.5	–	0.6	–	
HYPERRAM™ read initial access time - 1.8 V	t_{ACC}	35	–	36	–	ns
HYPERRAM™ read initial access time - 3.0 V		35	–	36	–	
Clock to DQs low Z	t_{DQLZ}	0	–	0	–	ns
CK transition to DQ valid - 1.8 V	t_{CKD}	1	5.0	1	5.5	ns
CK transition to DQ valid - 3.0 V		1	6.5	1	7	
CK transition to DQ invalid - 1.8 V	t_{CKDI}	0	4.2	0	4.6	ns
CK transition to DQ invalid - 3.0 V		0.5	5.7	0.5	5.6	
Data valid (t_{DV} min = the lesser of: t_{CKHP} min - t_{CKD} max + t_{CKDI} max) or t_{CKHP} min - t_{CKD} min + t_{CKDI} min) - 1.8 V	$t_{DV}^{[65, 66]}$	1.45	–	1.8	–	ns
Data valid (t_{DV} min = the lesser of: t_{CKHP} min - t_{CKD} max + t_{CKDI} max) or t_{CKHP} min - t_{CKD} min + t_{CKDI} min) - 3.0 V		1.45	–	1.3	–	
CK transition to RWDS valid - 1.8 V	t_{CKDS}	–	5.0	1	5.5	ns
CK transition to RWDS valid - 3.0 V		–	6.5	1	7	
RWDS transition to DQ valid - 1.8 V	t_{DSS}	–0.4	+0.4	–0.45	+0.45	ns
RWDS transition to DQ valid - 3.0 V		–0.4	+0.4	–0.45	+0.45	
RWDS transition to DQ invalid - 1.8 V	t_{DSH}	–0.4	+0.4	–0.45	+0.45	ns
RWDS transition to DQ invalid - 3.0 V		–0.4	+0.4	–0.45	+0.45	
Chip select hold after CK falling edge	t_{CSH}	0	–	0	–	ns

Notes

65. Refer to [Figure 33](#) for data valid timing.

66. The t_{DV} timing calculation is provided for reference only, not to determine the spec limit. The spec limit is guaranteed by testing.

Timing specifications

Table 29 HYPERRAM™ specific read timing parameters (Continued)

Parameter	Symbol	200 MHz		166 MHz		Unit
		Min	Max	Min	Max	
Chip select inactive to RWDS high-Z - 1.8 V	t_{DSZ}	-	5.0	-	6	ns
Chip select inactive to RWDS high-Z - 3.0 V		-	6.5	-	7	
Chip select inactive to DQ high-Z - 1.8 V	t_{OZ}	-	5	-	6	ns
Chip select inactive to DQ high-Z - 3.0 V		-	6.5	-	7	
Refresh time - 1.8 V	t_{RFH}	35	-	36	-	ns
Refresh time - 3.0 V		35	-	36	-	
CK transition to RWDS low @CA phase @read - 1.8 V	t_{CKDSR}	1	5.5	1	5.5	ns
CK transition to RWDS low @CA phase @read - 3.0 V		1	7	1	7	

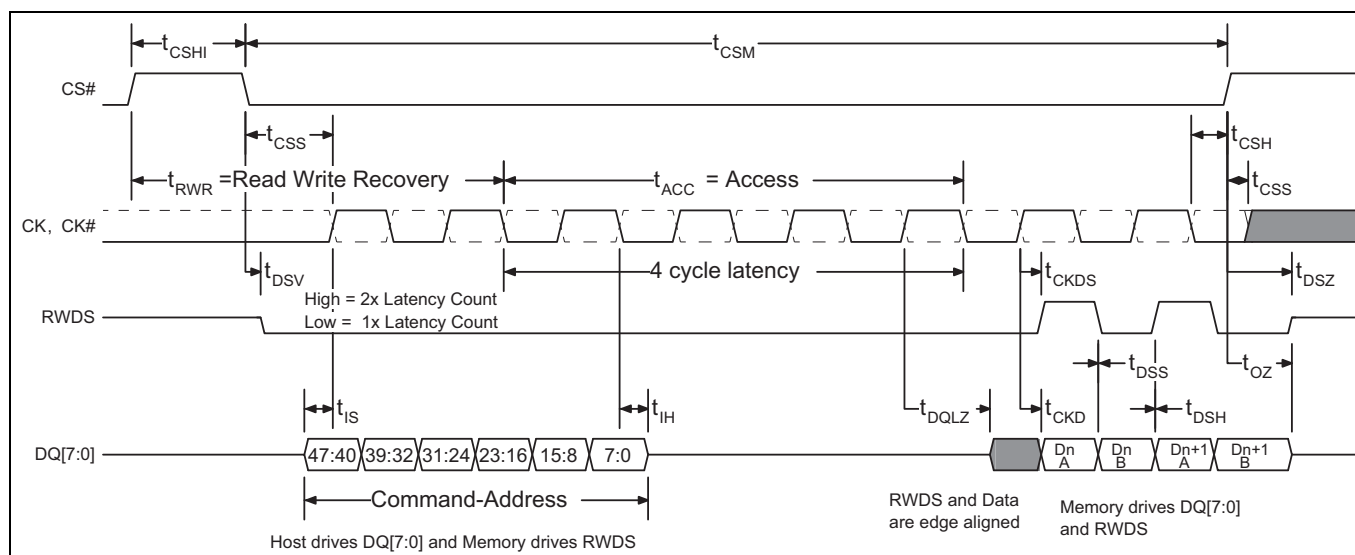

Figure 31 Read timing diagram — no additional latency required

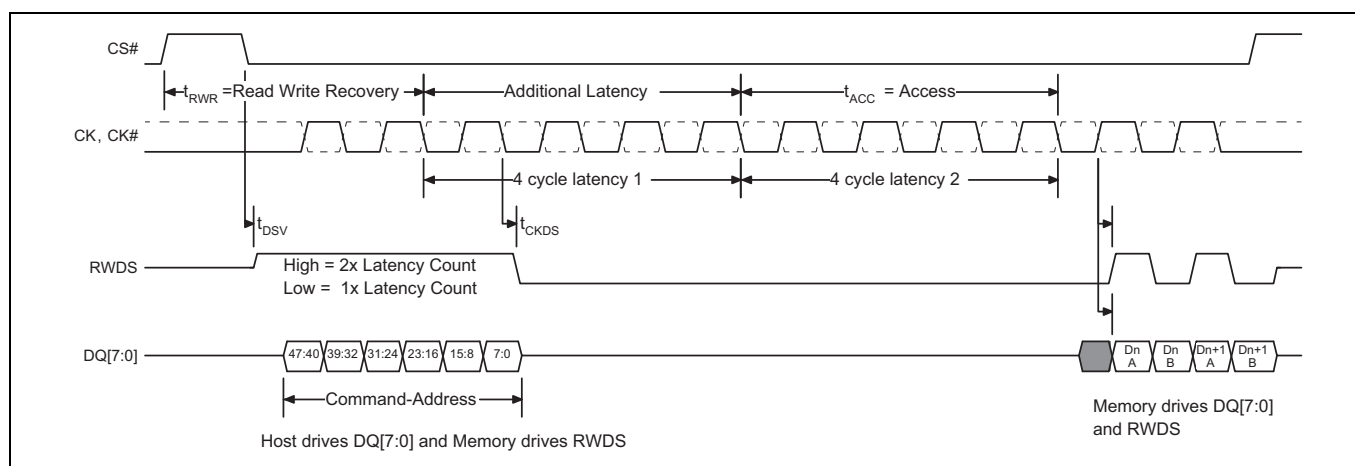

Figure 32 Read timing diagram — with additional latency required

Timing specifications

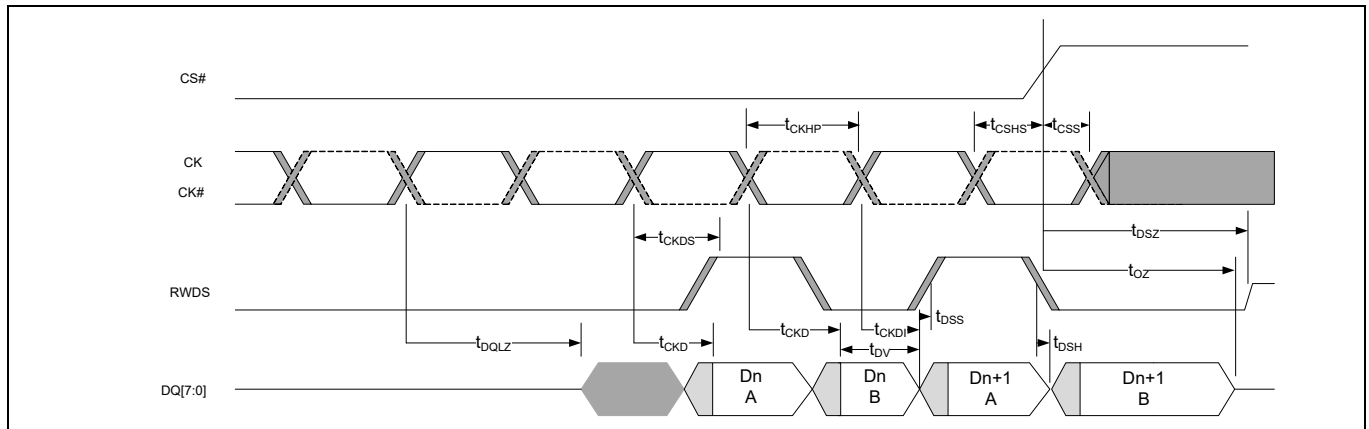

Figure 33 Data valid timing^[67-69]

10.5.2 Write transactions

Table 30 Write timing parameters

Parameter	Symbol	200 MHz		166 MHz		Unit
		Min	Max	Min	Max	
Read-write recovery time	t_{RWR}	35	–	36	–	ns
Access time	t_{ACC}	35	–	36	–	ns
Refresh time	t_{RFH}	35	–	36	–	ns
Chip select maximum low time (85 °C)	t_{CSM}	–	4	–	4	μs
Chip select maximum low time (105 °C)	t_{CSM}	–	1	–	1	μs
RWDS data mask valid	t_{DMV}	0	–	0	–	μs

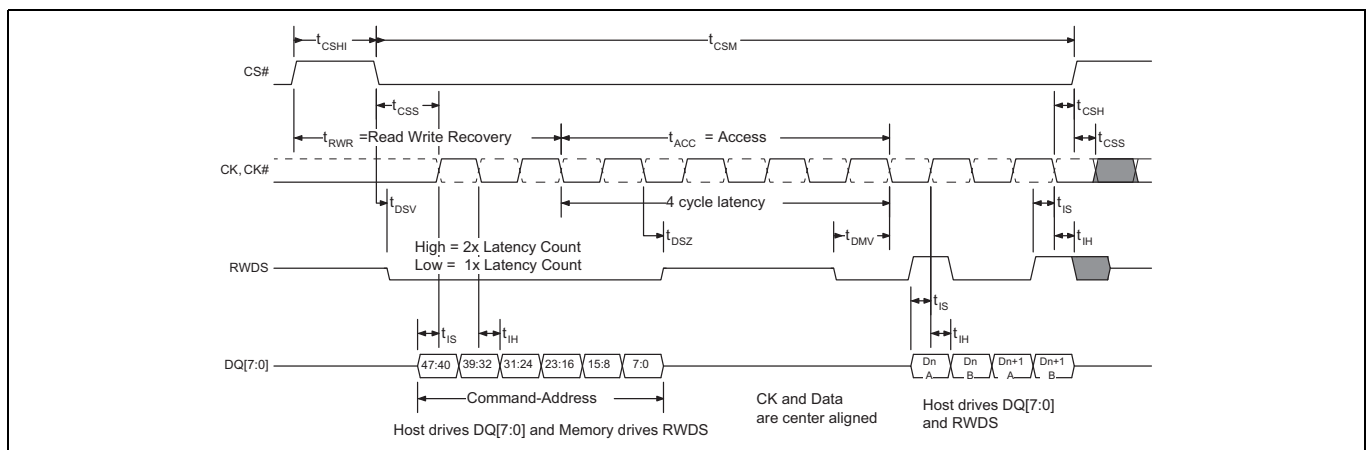

Figure 34 Write timing diagram – no additional latency

Notes

- 67. t_{CKD} and t_{CKDI} parameters define the beginning and end position of data valid period.
- 68. t_{DSS} and t_{DSH} define how early or late DQ may transition relative to RWDS. This is a potential skew between the CK to DQ delay t_{CKD} and CK to RWDS delay t_{CKDS} .
- 69. Since DQ and RWDS are the same output types, the t_{CKD} , and t_{CKDS} values track together (vary by the same ratio).

Physical interface

11 Physical interface

11.1 FBGA 24-ball 5 x 5 array footprint

HYPERRAM™ devices are provided in Fortified ball grid-array (FBGA), 1 mm pitch, 24-ball, 5 x 5 ball array footprint, with 6mm x 8mm body.

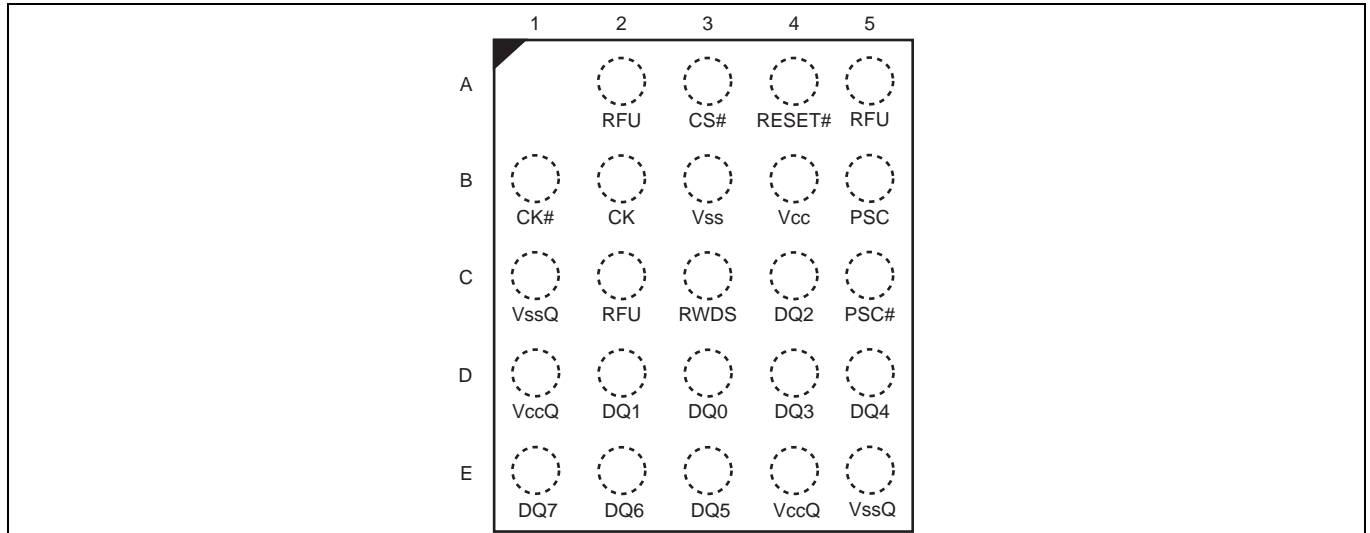

Figure 35 24-ball FBGA, 6 x 8 mm, 5 x 5 ball footprint, top view

12 Package diagram

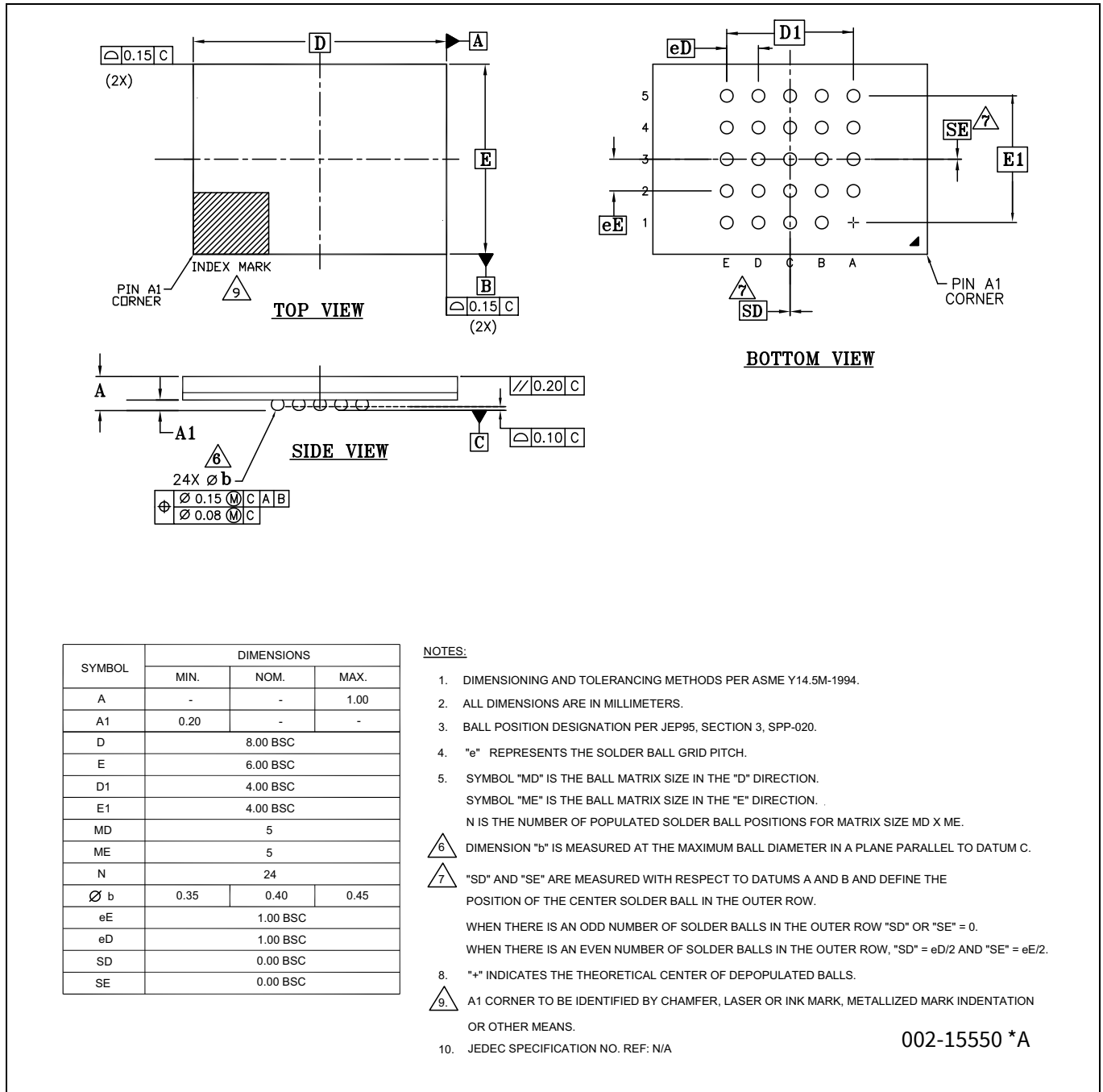

Figure 36 Fortified ball grid-array 24-ball 6 x 8 x 1.0 mm (VAA024)

13 DDR center-aligned read strobe (DCARS) functionality

The HYPERRAM™ device offers an optional feature that enables independent skewing (phase shifting) of the RWDS signal with respect to the read data outputs. This feature is provided in certain devices, based on the Ordering part number (OPN).

When the DCARS feature is provided, a second differential Phase Shifted Clock input PSC/PSC# is used as the reference for RWDS edges instead of CK/CK#. The second clock is generally a copy of CK/CK# that is phase shifted 90 degrees to place the RWDS edges centered within the DQ signals valid data window. However, other degrees of phase shift between CK/CK# and PSC/PSC# may be used to optimize the position of RWDS edges within the DQ signals valid data window so that RWDS provides the desired amount of data setup and hold time in relation to RWDS edges.

PSC/PSC# is not used during a write transaction. PSC and PSC# may be driven low and high respectively or, both may be driven low during write transactions.

The PSC/PSC# is used in HYPERBUS™ devices. If single-ended mode is selected, then PSC# must be driven low but must not be left floating (leakage concerns).

13.1 HYPERRAM™ products with DCARS signal descriptions

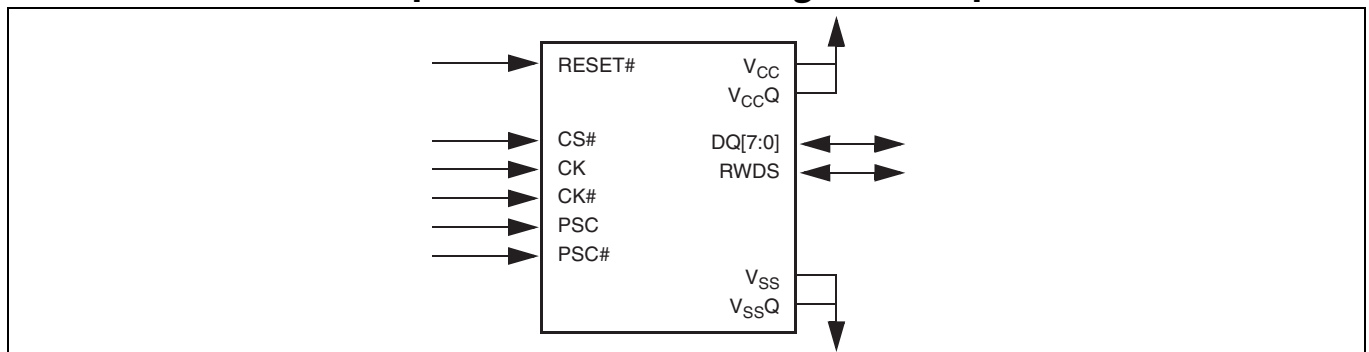

Figure 37 HYPERBUS™ product with DCARS signal diagram

Table 31 Signal descriptions

Symbol	Type	Description
CS#	Input	Chip select. HYPERBUS™ transactions are initiated with a high to low transition. HYPERBUS™ transactions are terminated with a low to high transition.
CK, CK#	Input	Differential clock. Command, address, and data information is output with respect to the crossing of the CK and CK# signals. Use of differential clock is optional. Single ended clock. CK# is not used, only a single ended CK is used. The clock is not required to be free-running.
PSC, PSC#	Input	Phase shifted clock. PSC/PSC# allows independent skewing of the RWDS signal with respect to the CK/CK# inputs. If the CK/CK# (differential mode) is configured, then PSC/PSC# are used. Otherwise, only PSC is used (single ended). PSC (and PSC#) may be driven high and low respectively or both may be driven low during write transactions.
RWDS	Output	Read-write data strobe. Data bytes output during read transactions are aligned with RWDS based on the phase shift from CK, CK# to PSC, PSC#. PSC, PSC# cause the transitions of RWDS, thus the phase shift from CK, CK# to PSC, PSC# is used to place RWDS edges within the data valid window. RWDS is an input during write transactions to function as a data mask. At the beginning of all bus transactions RWDS is an output and indicates whether additional initial latency count is required (1 = additional latency count, 0 = no additional latency count).

DDR center-aligned read strobe (DCARS) functionality

Table 31 Signal descriptions (Continued)

Symbol	Type	Description
DQ[7:0]	Input/Output	Data input/output. CA/Data information is transferred on these DQs during Read and write transactions.
RESET#	Input	Hardware reset. When low, the device will self initialize and return to the idle state. RWDS and DQ[7:0] are placed into the High-Z state when RESET# is low. RESET# includes a weak pull-up, if RESET# is left unconnected it will be pulled up to the high state.
V _{CC}	Power supply	Array power.
V _{CCQ}	Power supply	Input/output power.
V _{SS}	Power supply	Array ground.
V _{SSQ}	Power supply	Input/output ground.

13.2 HYPERRAM™ products with DCARS – FBGA 24-ball, 5 x 5 array footprint

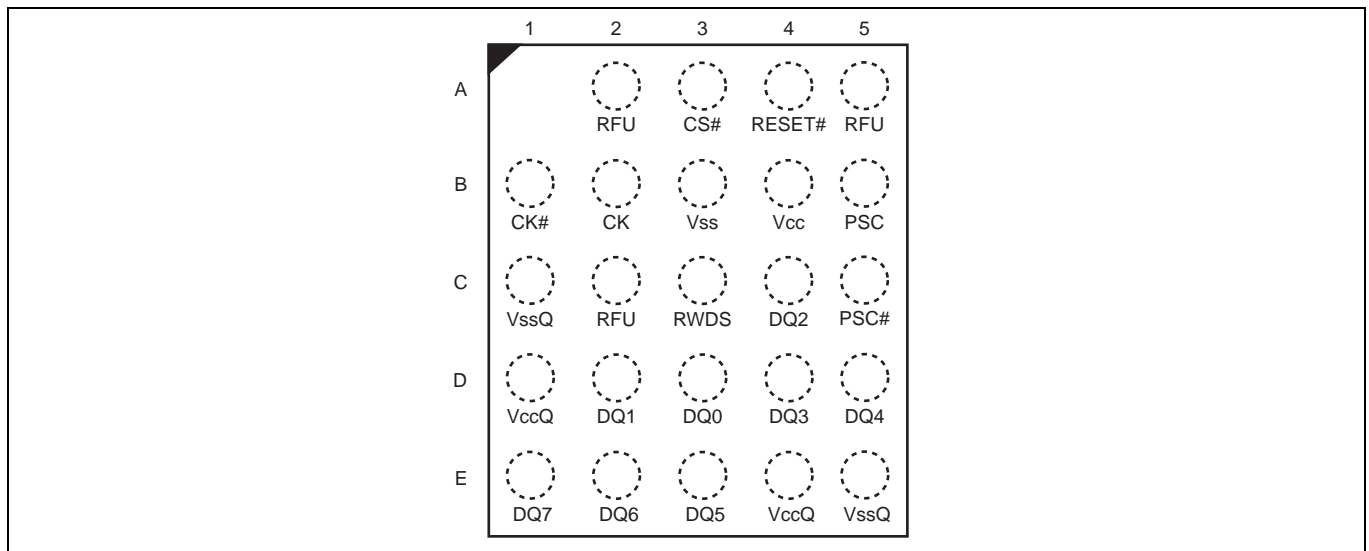

Figure 38 24-ball FBGA, 6 x 8 mm, 5 x 5 ball footprint, top view

13.3 HYPERRAM™ memory with DCARS timing

The illustrations and parameters shown here are only those needed to define the DCARS feature and show the relationship between the Phase shifted clock, RWDS, and data.

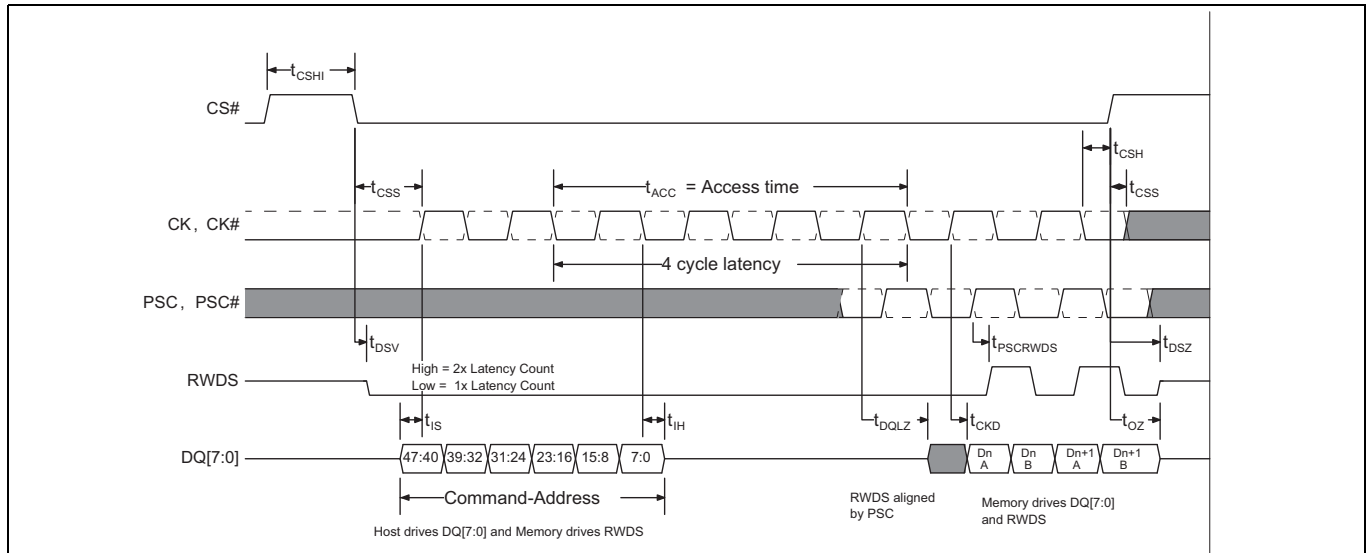

Figure 39 HYPERRAM™ memory DCARS timing diagram^[70-72]

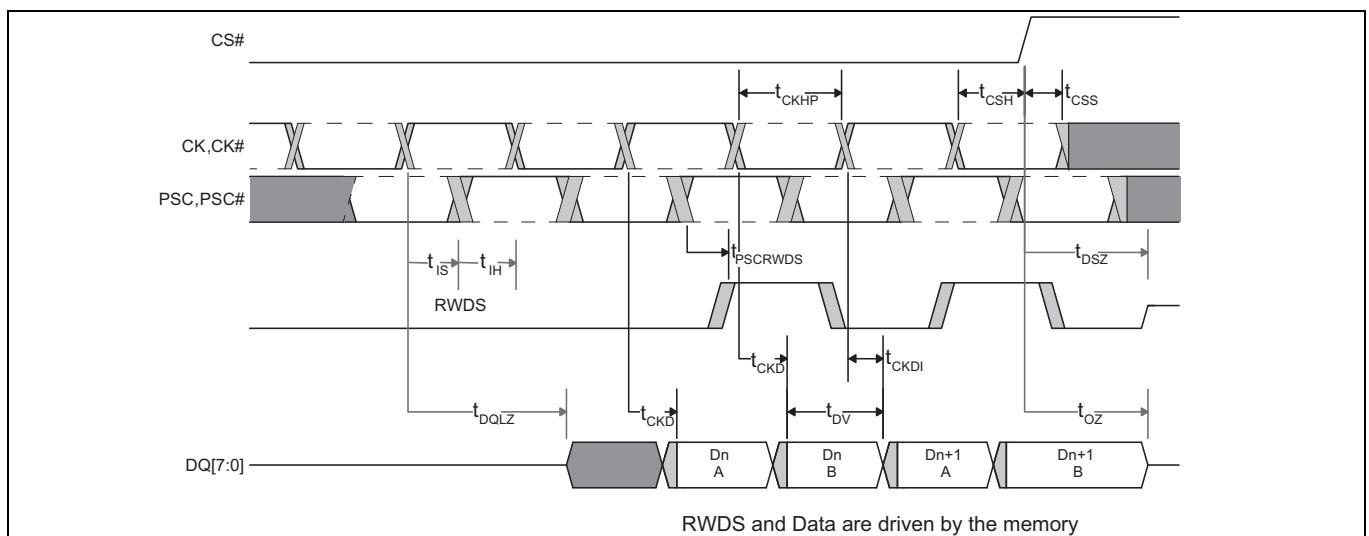

Figure 40 DCARS data valid timing^[73-75]

Notes

70. Transactions must be initiated with CK = low and CK# = high. CS# must return high before a new transaction is initiated.
71. The memory drives RWDS during read transactions.
72. This example demonstrates a latency code setting of four clocks and no additional initial latency required.
73. This figure shows a closer view of the data transfer portion of [Figure 37](#) in order to more clearly show the Data valid period as affected by clock jitter and clock to output delay uncertainty.
74. The delay (phase shift) from CK to PSC is controlled by the HYPERBUS™ master interface (Host) and is generally between 40 and 140 degrees in order to place the RWDS edge within the data valid window with sufficient set-up and hold time of data to RWDS. The requirements for data set-up and hold time to RWDS are determined by the HYPERBUS™ master interface design and are not addressed by the HYPERBUS™ slave timing parameters.
75. The HYPERBUS™ timing parameters of t_{CKD} , and t_{CKDI} define the beginning and end position of the data valid period. The t_{CKD} and t_{CKDI} values track together (vary by the same ratio) because RWDS and Data are outputs from the same device under the same voltage and temperature conditions.

**64-Mb HYPERRAM™ self-refresh DRAM (PSRAM)
HYPERBUS™ interface, 1.8 V/3.0 V**



DDR center-aligned read strobe (DCARS) functionality

Table 32 DCARS read timing

Parameter	Symbol	200 MHz		166 MHz		Unit
		Min	Max	Min	Max	
Input setup - CK/CK# setup w.r.t PSC/PSC# (edge to edge)	t_{IS}	0.5	–	0.6	–	ns
CK half period - duty cycle (edge to edge)	t_{IH}	0.5	–	0.6	–	ns
HYPERRAM™ PSC transition to RWDS transition	$t_{PSCRWDS}$	–	5	–	6.5	ns
Time delta between CK to DQ valid and PSC to RWDS ^[76]	$t_{PSCRWDS} - t_{CKD}$	-1.0	+0.5	-1.0	+0.5	ns

Note

76. Sampled, not 100% tested.

14 Ordering information

14.1 Ordering part number

The ordering part number is formed by a valid combination of the following:

S27KS	064	2	DP	B	H	I	02	0
								Packing type 0 = Tray 3 = 13" Tape and reel
								Model number (Additional ordering options) 02 = Standard 6 × 8 × 1.0 mm package (VAA024) 03 = DDR center-aligned read strobe (DCARS) 6 × 8 × 1.0 mm package (VAA024)
								Temperature range / grade I = Industrial (-40 °C to + 85 °C) V = Industrial plus (-40 °C to + 105 °C) A = Automotive, (-40 °C to + 85 °C) B = Automotive, AEC-Q100 grade 2 (-40 °C to + 105 °C)
								Package materials H = Low-halogen, Pb-free
								Package type B = 24-ball FBGA, 1.00 mm pitch (5x5 ball footprint)
								Speed GA = 200 MHz DP = 166 MHz
								Device technology 2 = 38-nm DRAM process technology - HYPERBUS™ 3 = 38-nm DRAM Process technology - Octal
								Density 064 = 64 Mb
								Device family S27KS 1.8 V-only, HYPERRAM™ self-refresh DRAM S27KL 3.0 V-only, HYPERRAM™ self-refresh DRAM

14.2 Valid combinations

The Recommended combinations table lists configurations planned to be available in volume. **Table 33** will be updated as new combinations are released. Contact your local sales representative to confirm availability of specific combinations and to check on newly released combinations.

Table 33 Valid Combinations – Standard

Device family	Density	Technology	Speed	Package, material, and temperature	Model number	Packing type	Ordering part number	Package marking
S27KL	064	2	DP	BHI	02	0	S27KL0642DPBHI020	7KL0642DPHI02
S27KL	064	2	DP	BHI	02	3	S27KL0642DPBHI023	7KL0642DPHI02
S27KL	064	2	GA	BHI	02	0	S27KL0642GABHI020	7KL0642GAHI02
S27KL	064	2	GA	BHI	02	3	S27KL0642GABHI023	7KL0642GAHI02
S27KL	064	2	DP	BHV	02	0	S27KL0642DPBHV020	7KL0642DPHV02
S27KL	064	2	DP	BHV	02	3	S27KL0642DPBHV023	7KL0642DPHV02
S27KL	064	2	GA	BHV	02	0	S27KL0642GABHV020	7KL0642GAHV02
S27KL	064	2	GA	BHV	02	3	S27KL0642GABHV023	7KL0642GAHV02
S27KS	064	2	GA	BHI	02	0	S27KS0642GABHI020	7KS0642GAHI02
S27KS	064	2	GA	BHI	02	3	S27KS0642GABHI023	7KS0642GAHI02
S27KS	064	2	GA	BHV	02	0	S27KS0642GABHV020	7KS0642GAHV02
S27KS	064	2	GA	BHV	02	3	S27KS0642GABHV023	7KS0642GAHV02

14.3 Valid combinations — Automotive grade / AEC-Q100

Table 34 list configurations that are Automotive grade / AEC-Q100 qualified and are planned to be available in volume. The table will be updated as new combinations are released. Contact your local sales representative to confirm availability of specific combinations and to check on newly released combinations.

Production part approval process (PPAP) support is only provided for AEC-Q100 grade products.

Products to be used in end-use applications that require ISO/TS-16949 compliance must be AEC-Q100 grade products in combination with PPAP. Non-AEC-Q100 grade products are not manufactured or documented in full compliance with ISO/TS-16949 requirements.

AEC-Q100 grade products are also offered without PPAP support for end-use applications that do not require ISO/TS-16949 compliance.

Table 34 Valid Combinations — Automotive grade / AEC-Q100

Device family	Density	Technology	Speed	Package, material, and temperature	Model number	Packing type	Ordering part number	Package marking
S27KL	064	2	DP	BHA	02	0	S27KL0642DPBHA020	7KL0642DPHA02
S27KL	064	2	DP	BHA	02	3	S27KL0642DPBHA023	7KL0642DPHA02
S27KL	064	2	GA	BHA	02	0	S27KL0642GABHA020	7KL0642GAHA02
S27KL	064	2	GA	BHA	02	3	S27KL0642GABHA023	7KL0642GAHA02
S27KL	064	2	DP	BHB	02	0	S27KL0642DPBHB020	7KL0642DPHB02
S27KL	064	2	DP	BHB	02	3	S27KL0642DPBHB023	7KL0642DPHB02
S27KL	064	2	GA	BHB	02	0	S27KL0642GABHB020	7KL0642GAHB02
S27KL	064	2	GA	BHB	02	3	S27KL0642GABHB023	7KL0642GAHB02
S27KS	064	2	GA	BHA	02	0	S27KS0642GABHA020	7KS0642GAHA02
S27KS	064	2	GA	BHA	02	3	S27KS0642GABHA023	7KS0642GAHA02
S27KS	064	2	GA	BHB	02	0	S27KS0642GABHB020	7KS0642GAHB02
S27KS	064	2	GA	BHB	02	3	S27KS0642GABHB023	7KS0642GAHB02

Revision history

Document version	Date of release	Description of changes
*F	2019-11-25	Changed document status to Final.
*G	2020-05-05	<p>Added note in Figure 13. Updated t_{CKDS} and t_{CKD} in Figure 32. Updated Hybrid Burst Enable binary in Table 9. Added Hybrid 128 burst in Table 11. Fixed typos in Table 12 and Table 27. Updated parameters in Table 17. Added Thermal values in Table 20. Added Figure 27 and Figure 28 in “Timing reference levels” on page 42. Added ESD information in “Electrical specifications” on page 31. Added Figure 30 Differential Clock (CK/CK#) Input Swing. Removed Valid Combinations — DCARS MPNs in “Valid combinations” on page 55. Removed Valid Combinations — DCARS Automotive Grade / AEC-Q100 MPNs in “Valid combinations — Automotive grade / AEC-Q100” on page 56.</p>
*H	2022-01-18	<p>Updated Table 15 with HS setting. Updated leakage current specifications in Table 18. Updated “Master clock type” on page 26. Updated Figure 27 and Figure 28 for input and output measurement reference level. Updated t_{DSS} and t_{DSH} for 166MHz, added note 71 on t_{DV} in Table 29. Added Figure 33 on “Data valid timing”. Updated ordering part numbers in Table 33 and Table 34. Migrated to IFX template.</p>

Trademarks

All referenced product or service names and trademarks are the property of their respective owners.

Edition 2022-01-18
Published by
Infineon Technologies AG
81726 Munich, Germany

© 2022 Infineon Technologies AG.
All Rights Reserved.

Do you have a question about this document?
Go to www.infineon.com/support

Document reference
002-24692 Rev. *H

IMPORTANT NOTICE

The information given in this document shall in no event be regarded as a guarantee of conditions or characteristics ("Beschaffenhheitsgarantie").

With respect to any examples, hints or any typical values stated herein and/or any information regarding the application of the product, Infineon Technologies hereby disclaims any and all warranties and liabilities of any kind, including without limitation warranties of non-infringement of intellectual property rights of any third party.

In addition, any information given in this document is subject to customer's compliance with its obligations stated in this document and any applicable legal requirements, norms and standards concerning customer's products and any use of the product of Infineon Technologies in customer's applications.

The data contained in this document is exclusively intended for technically trained staff. It is the responsibility of customer's technical departments to evaluate the suitability of the product for the intended application and the completeness of the product information given in this document with respect to such application.

For further information on the product, technology, delivery terms and conditions and prices please contact your nearest Infineon Technologies office (www.infineon.com).

WARNINGS

Due to technical requirements products may contain dangerous substances. For information on the types in question please contact your nearest Infineon Technologies office.

Except as otherwise explicitly approved by Infineon Technologies in a written document signed by authorized representatives of Infineon Technologies, Infineon Technologies' products may not be used in any applications where a failure of the product or any consequences of the use thereof can reasonably be expected to result in personal injury.