

# S25FL128P

**128 Megabit CMOS 3.0 Volt Flash Memory  
with 104-MHz SPI (Serial Peripheral Interface) Bus**

*Data Sheet (Preliminary)*

---



**Notice to Readers:** This document states the current technical specifications regarding the Spansion product(s) described herein. Spansion Inc. deems the products to have been in sufficient production volume such that subsequent versions of this document are not expected to change. However, typographical or specification corrections, or modifications to the valid combinations offered may occur.

## Notice On Data Sheet Designations

Spansion Inc. issues data sheets with Advance Information or Preliminary designations to advise readers of product information or intended specifications throughout the product life cycle, including development, qualification, initial production, and full production. In all cases, however, readers are encouraged to verify that they have the latest information before finalizing their design. The following descriptions of Spansion data sheet designations are presented here to highlight their presence and definitions.

### Advance Information

The Advance Information designation indicates that Spansion Inc. is developing one or more specific products, but has not committed any design to production. Information presented in a document with this designation is likely to change, and in some cases, development on the product may discontinue. Spansion Inc. therefore places the following conditions upon Advance Information content:

“This document contains information on one or more products under development at Spansion Inc. The information is intended to help you evaluate this product. Do not design in this product without contacting the factory. Spansion Inc. reserves the right to change or discontinue work on this proposed product without notice.”

### Preliminary

The Preliminary designation indicates that the product development has progressed such that a commitment to production has taken place. This designation covers several aspects of the product life cycle, including product qualification, initial production, and the subsequent phases in the manufacturing process that occur before full production is achieved. Changes to the technical specifications presented in a Preliminary document should be expected while keeping these aspects of production under consideration. Spansion places the following conditions upon Preliminary content:

“This document states the current technical specifications regarding the Spansion product(s) described herein. The Preliminary status of this document indicates that product qualification has been completed, and that initial production has begun. Due to the phases of the manufacturing process that require maintaining efficiency and quality, this document may be revised by subsequent versions or modifications due to changes in technical specifications.”

### Combination

Some data sheets contain a combination of products with different designations (Advance Information, Preliminary, or Full Production). This type of document distinguishes these products and their designations wherever necessary, typically on the first page, the ordering information page, and pages with the DC Characteristics table and the AC Erase and Program table (in the table notes). The disclaimer on the first page refers the reader to the notice on this page.

### Full Production (No Designation on Document)

When a product has been in production for a period of time such that no changes or only nominal changes are expected, the Preliminary designation is removed from the data sheet. Nominal changes may include those affecting the number of ordering part numbers available, such as the addition or deletion of a speed option, temperature range, package type, or  $V_{IO}$  range. Changes may also include those needed to clarify a description or to correct a typographical error or incorrect specification. Spansion Inc. applies the following conditions to documents in this category:

“This document states the current technical specifications regarding the Spansion product(s) described herein. Spansion Inc. deems the products to have been in sufficient production volume such that subsequent versions of this document are not expected to change. However, typographical or specification corrections, or modifications to the valid combinations offered may occur.”

Questions regarding these document designations may be directed to your local sales office.

# S25FL128P

## 128 Megabit CMOS 3.0 Volt Flash Memory with 104-MHz SPI (Serial Peripheral Interface) Bus

Data Sheet (Preliminary)



### Distinctive Characteristics

#### Architectural Advantages

- **Single power supply operation**
  - Full voltage range: 2.7 to 3.6 V read and program operations
- **Memory Architecture**
  - 128Mb uniform 256 KB sector product
  - 128Mb uniform 64 KB sector product
- **Program**
  - Page Program (up to 256 bytes) in 1.5 ms (typical)
  - Faster program time in Accelerated Programming mode (8.5 V–9.5 V on #WP/ACC) in 1.2 ms (typical)
- **Erase**
  - 2 s typical 256 KB sector erase time
  - 0.5 s typical 64 KB sector erase time
  - 128 s typical bulk erase time
  - Sector erase (SE) command (D8h) for 256 KB sectors; (20h or D8h) for 64KB sectors
  - Bulk erase command (C7h) for 256 KB sectors; (60h or C7h) for 64KB sectors
- **Cycling Endurance**
  - 100,000 cycles per sector typical
- **Data Retention**
  - 20 years typical
- **Device ID**
  - RDID (9Fh), READ\_ID (90h) and RES (ABh) commands to read manufacturer and device ID information
  - RES command one-byte electronic signature for backward compatibility

#### Process Technology

- Manufactured on 0.09  $\mu\text{m}$  MirrorBit® process technology

#### Package Option

- Industry Standard Pinouts
- 16-pin SO package (300 mils)
- 8-Contact WSON Package (6 x 8 mm)

#### Performance Characteristics

- **Speed**
  - 104 MHz clock rate (maximum)
- **Power Saving Standby Mode**
  - Standby Mode 200  $\mu\text{A}$  (max)
  - Deep Power Down Mode 3  $\mu\text{A}$  (typical)

#### Memory Protection Features

- **Memory Protection**
  - WP#/ACC pin works in conjunction with Status Register Bits to protect specified memory areas
  - 256 KB uniform sector product: Status Register Block Protection bits (BP2, BP1, BP0) in status register configure parts of memory as read-only.
  - 64KB uniform sector product: Status Register Block Protection bits (BP3, BP2, BP1, BP0) in status register configure parts of memory as read-only

#### Software Features

- SPI Bus Compatible Serial Interface

#### Hardware Features

- **x8 Parallel Programming Mode (for 16-pin SO package only)**

### General Description

The S25FL128P is a 3.0 Volt (2.7 V to 3.6 V), single-power-supply Flash memory device. The device consists of 64 sectors of 256 KB memory, or 256 sectors of 64 KB memory.

The device accepts data written to SI (Serial Input) and outputs data on SO (Serial Output). The devices are designed to be programmed in-system with the standard system 3.0 volt  $V_{CC}$  supply.

The memory can be programmed 1 to 256 bytes at a time, using the Page Program command. The device supports Sector Erase and Bulk Erase commands.

Each device requires only a 3.0 volt power supply (2.7 V to 3.6 V) for both read and write functions. Internally generated and regulated voltages are provided for the program operations. This device requires a high voltage supply to WP#/ACC pin for the Accelerated Programming mode.

## Table of Contents

<b>Distinctive Characteristics</b> .....	3
<b>General Description</b> .....	3
<b>1. Block Diagram</b> .....	7
<b>2. Connection Diagrams</b> .....	8
<b>3. Input/Output Descriptions</b> .....	9
<b>4. Logic Symbol</b> .....	9
<b>5. Ordering Information</b> .....	10
5.1 Valid Combinations .....	10
<b>6. Spansion SPI Modes</b> .....	11
<b>7. Device Operations</b> .....	12
7.1 Byte or Page Programming .....	12
7.2 Sector Erase / Bulk Erase .....	12
7.3 Monitoring Write Operations Using the Status Register .....	12
7.4 Active Power and Standby Power Modes .....	12
7.5 Status Register .....	12
7.6 Data Protection Modes .....	12
7.7 Hold Mode (HOLD#) .....	14
<b>8. Sector Address Table</b> .....	14
<b>9. Parallel Mode (for 16-pin SO package only)</b> .....	18
<b>10. Accelerated Programming Operation</b> .....	18
<b>11. Command Definitions</b> .....	19
11.1 Read Data Bytes (READ: 03h) .....	19
11.2 Read Data Bytes at Higher Speed (FAST_READ: 0Bh) .....	21
11.3 Read Identification (RDID: 9Fh) .....	22
11.4 Read Manufacturer and Device ID (READ_ID: 90h) .....	24
11.5 Write Enable (WREN: 06h) .....	25
11.6 Write Disable (WRDI: 04h) .....	26
11.7 Read Status Register (RDSR: 05h) .....	26
11.8 Write Status Register (WRSR: 01h) .....	29
11.9 Page Program (PP: 02h) .....	30
11.10 Sector Erase (SE: 20h, D8h) .....	33
11.11 Bulk Erase (BE: C7h, 60h) .....	34
11.12 Deep Power Down (DP: B9h) .....	35
11.13 Release from Deep Power Down (RES: ABh) .....	36
11.14 Release from Deep Power Down and Read Electronic Signature (RES: ABh) .....	36
11.15 Command Definitions .....	38
<b>12. Program Acceleration via WP#/ACC pin</b> .....	38
<b>13. Power-up and Power-down</b> .....	39
<b>14. Initial Delivery State</b> .....	39
<b>15. Absolute Maximum Ratings</b> .....	40
<b>16. Operating Ranges</b> .....	40
<b>17. DC Characteristics</b> .....	41
<b>18. Test Conditions</b> .....	41
<b>19. AC Characteristics</b> .....	42
<b>20. Physical Dimensions</b> .....	45
20.1 SO3 016 wide—16-pin Plastic Small Outline Package (300-mil Body Width) .....	45
20.2 WSON 8-contact (6 x 8 mm) No-Lead Package .....	46
<b>21. Revision History</b> .....	47

## Figures

Figure 2.1	16-pin Plastic Small Outline Package (SO) . . . . .	8
Figure 2.2	8-Pin WSON Package (6 x 8 mm) . . . . .	8
Figure 6.1	Bus Master and Memory Devices on the SPI Bus . . . . .	11
Figure 6.2	SPI Modes Supported . . . . .	11
Figure 7.1	Hold Mode Operation . . . . .	14
Figure 11.1	Read Data Bytes (READ) Command Sequence . . . . .	19
Figure 11.2	Parallel Read Instruction Sequence . . . . .	20
Figure 11.3	Read Data Bytes at Higher Speed (FAST_READ) Command Sequence . . . . .	21
Figure 11.4	Read Identification Command Sequence and Data Out Sequence . . . . .	22
Figure 11.5	Parallel Read_ID Command Sequence and Data Out Sequence . . . . .	23
Figure 11.6	Serial READ_ID Instruction Sequence . . . . .	24
Figure 11.7	Parallel Read_ID Instruction Sequence . . . . .	25
Figure 11.8	Write Enable (WREN) Command Sequence . . . . .	25
Figure 11.9	Write Disable (WRDI) Command Sequence . . . . .	26
Figure 11.10	Read Status Register (RDSR) Command Sequence . . . . .	27
Figure 11.11	Parallel Read Status Register (RDSR) Instruction Sequence . . . . .	28
Figure 11.12	Write Status Register (WRSR) Command Sequence . . . . .	29
Figure 11.13	Parallel Write Status Register (WRSR) Command Sequence . . . . .	29
Figure 11.14	Page Program (PP) Command Sequence . . . . .	31
Figure 11.15	Parallel Page Program (PP) Instruction Sequence . . . . .	32
Figure 11.16	Sector Erase (SE) Command Sequence . . . . .	33
Figure 11.17	Bulk Erase (BE) Command Sequence . . . . .	34
Figure 11.18	Deep Power Down (DP) Command Sequence . . . . .	35
Figure 11.19	Release from Deep Power Down (RES) Command Sequence . . . . .	36
Figure 11.20	Serial Release from Deep Power Down and Read Electronic Signature (RES) Command Sequence . . . . .	37
Figure 11.21	Parallel Release from Deep Power Down and Read Electronic Signature (RES) Command Sequence . . . . .	37
Figure 12.1	ACC Program Acceleration Timing Requirements . . . . .	38
Figure 13.1	Power-Up Timing Diagram . . . . .	39
Figure 15.1	Maximum Negative Overshoot Waveform . . . . .	40
Figure 15.2	Maximum Positive Overshoot Waveform . . . . .	40
Figure 18.1	AC Measurements I/O Waveform . . . . .	41
Figure 19.1	SPI Mode 0 (0,0) Input Timing . . . . .	43
Figure 19.2	SPI Mode 0 (0,0) Output Timing . . . . .	43
Figure 19.3	HOLD# Timing . . . . .	44
Figure 19.4	Write Protect Setup and Hold Timing during WRSR when SRWD=1 . . . . .	44

## Tables

Table 5.1	S25FL128P Valid Combinations Table	10
Table 7.1	S25FL128P Protected Area Sizes (Uniform 256 KB sector)	13
Table 7.2	S25FL128P Protected Area Sizes (Uniform 64 KB sector)	13
Table 8.1	S25FL128P Device Organization	14
Table 8.2	S25FL128P Sector Address Table (Uniform 256 KB sector)	15
Table 8.3	S25FL128P Sector Address Table (Uniform 64 KB sector)	16
Table 11.1	Manufacturer & Device Identification, RDID (9Fh)	23
Table 11.2	READ_ID Command and Data	25
Table 11.3	S25FL128P Status Register (Uniform 256 KB sector)	26
Table 11.4	S25FL128P Status Register (Uniform 64 KB sector)	27
Table 11.5	Protection Modes	30
Table 11.6	Command Definitions	38
Table 12.1	ACC Program Acceleration Specifications	38
Table 13.1	Power-Up Timing Characteristics	39
Table 15.1	Absolute Maximum Ratings	40
Table 16.1	Operating Ranges	40
Table 17.1	DC Characteristics (CMOS Compatible)	41
Table 18.1	Test Specifications	41
Table 19.1	AC Characteristics	42

# 1. Block Diagram

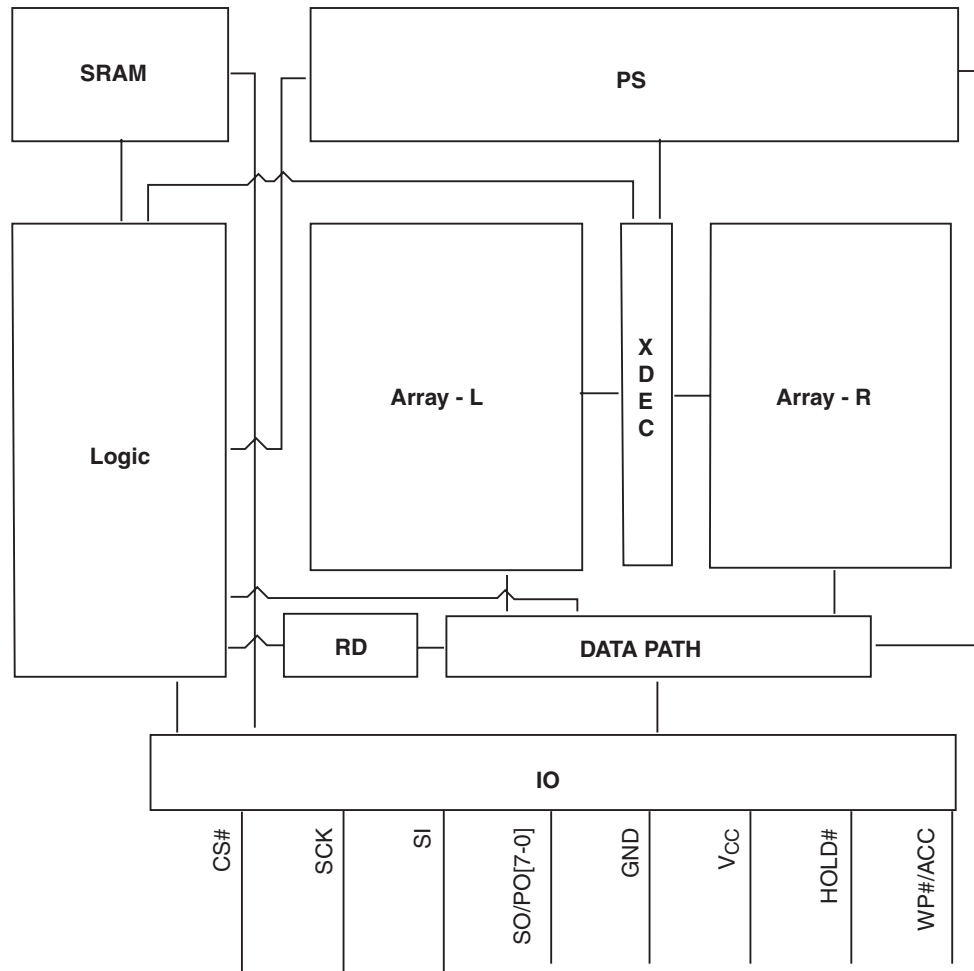

## 2. Connection Diagrams

**Figure 2.1** 16-pin Plastic Small Outline Package (SO)

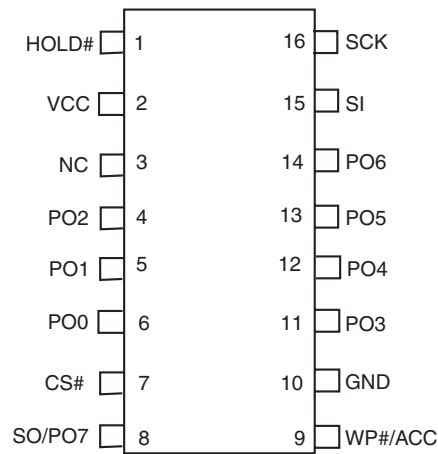

**Figure 2.2** 8-Pin WSON Package (6 x 8 mm)

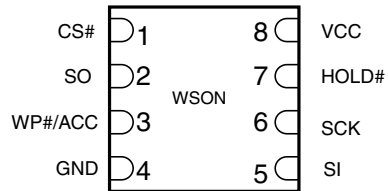



### 3. Input/Output Descriptions

Signal Name	I/O	Description
SO (Signal Data Output)	Output	Transfers data serially out of the device on the falling edge of SCK.
PO[7-0] (Parallel Data Input/Output)	Input/Output	Transfers parallel data into the device on the rising edge of SCK or out of the device on the falling edge of SCK.
SI (Serial Data Input)	Input	Transfers data serially into the device. Device latches commands, addresses, and program data on SI on the rising edge of SCK.
SCK (Serial Clock)	Input	Provides serial interface timing. Latches commands, addresses, and data on SI on rising edge of SCK. Triggers output on SO after the falling edge of SCK.
CS# (Chip Select)	Input	Places device in active power mode when driven low. Deselects device and places SO at high impedance when high. After power-up, device requires a falling edge on CS# before any command is written. Device is in standby mode when a program, erase, or Write Status Register operation is not in progress.
HOLD# (Hold)	Input	Pauses any serial communication with the device without deselecting it. When driven low, SO is at high impedance, and all input at SI and SCK are ignored. Requires that CS# also be driven low.
WP#/ACC (Write Protect/Accelerated Programming)	Input	When driven low, prevents any program or erase command from altering the data in the protected memory area specified by Status Register bits (BP bits). If the system asserts $V_{HH}$ on this pin, accelerated programming operation is provided.
$V_{CC}$	Input	Supply Voltage
GND	Input	Ground

### 4. Logic Symbol

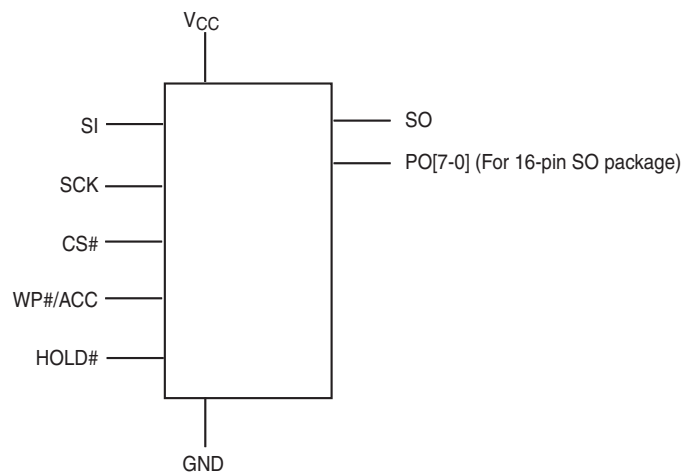

## 5. Ordering Information

The ordering part number is formed by a valid combination of the following:

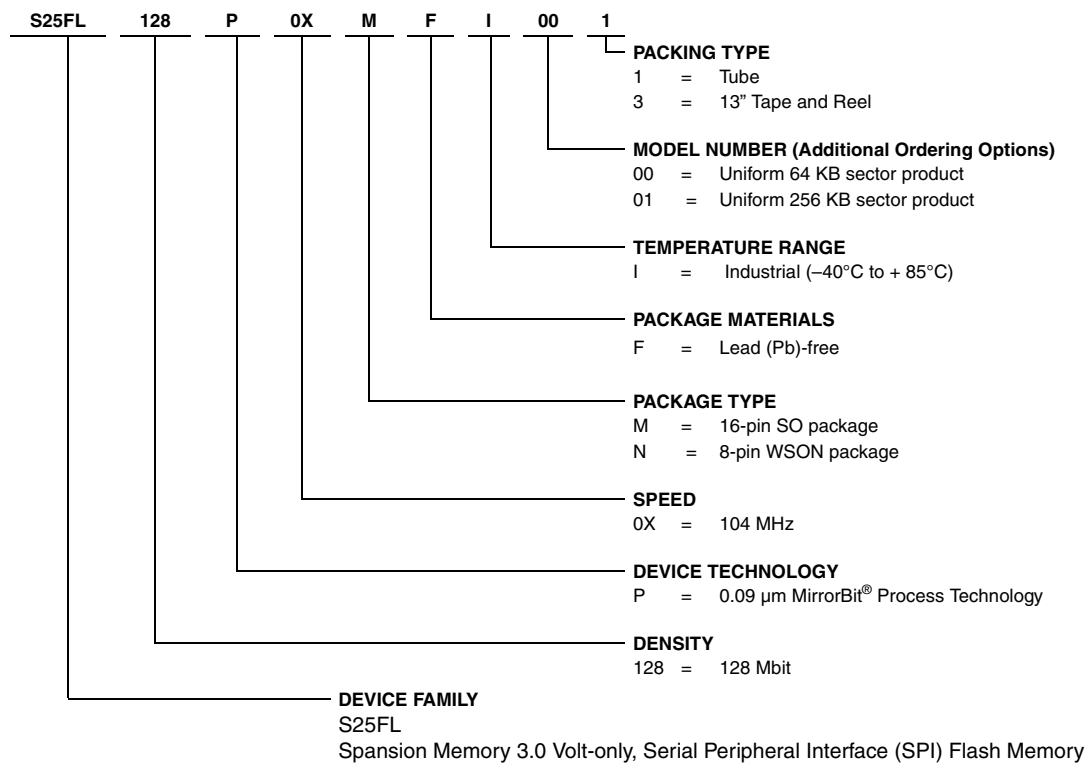

**Table 5.1** S25FL128P Valid Combinations Table

S25FL128P Valid Combinations					Package Marking (See Note)
Base Ordering Part Number	Speed Option	Package & Temperature	Model Number	Packing Type	
S25FL128P	0X	MFI, NFI	00	1, 3	FL128P + I + F
			01		FL128P + I + FL

**Note**

Package marking omits leading "S25" and speed, package, and model number form.

### 5.1 Valid Combinations

Table 5.1 lists the valid combinations configurations planned to be supported in volume for this device.

## 6. Spansion SPI Modes

A microcontroller can use either of its two SPI modes to control Spansion SPI Flash memory devices:

- CPOL = 0, CPHA = 0 (Mode 0)
- CPOL = 1, CPHA = 1 (Mode 3)

Input data is latched in on the rising edge of SCK, and output data is available from the falling edge of SCK for both modes.

When the bus master is in standby mode, SCK is as shown in [Figure 6.2](#) for each of the two modes:

- SCK remains at 0 for (CPOL = 0, CPHA = 0 Mode 0)
- SCK remains at 1 for (CPOL = 1, CPHA = 1 Mode 3)

**Figure 6.1** Bus Master and Memory Devices on the SPI Bus

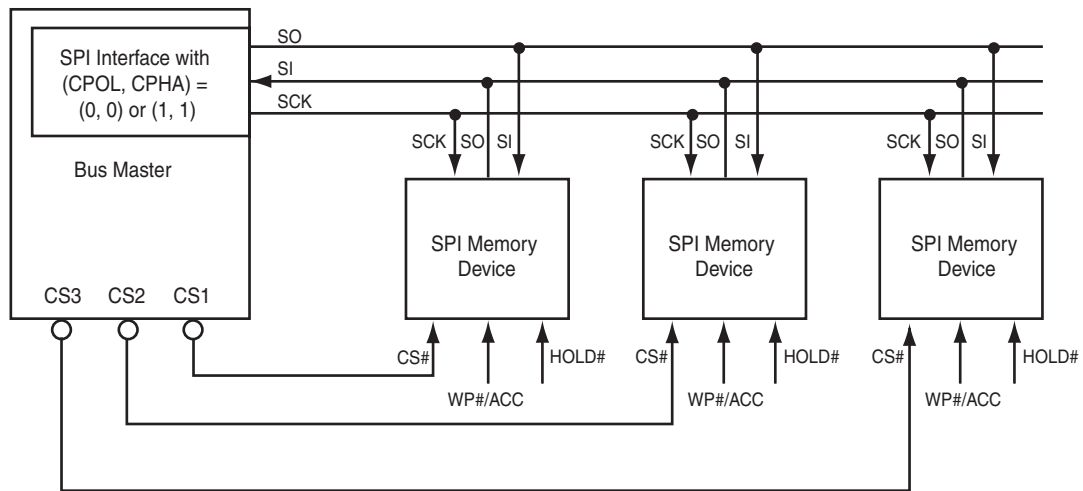

**Note**

The Write Protect/Accelerated Programming (WP#/ACC) and Hold (HOLD#) signals should be driven high (logic level 1) or low (logic level 0) as appropriate.

**Figure 6.2** SPI Modes Supported

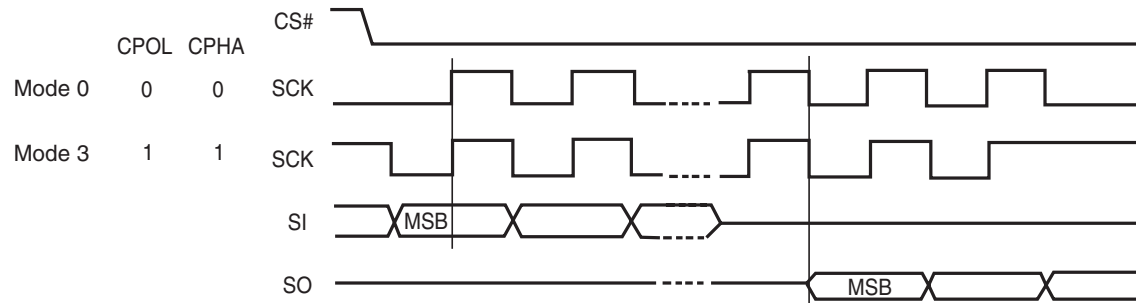

## 7. Device Operations

All Spansion SPI devices (S25FL-P) accept and output data in bytes (8 bits at a time).

### 7.1 Byte or Page Programming

Programming data requires two commands: Write Enable (WREN), which is one byte, and a Page Program (PP) sequence, which consists of four bytes plus data. The Page Program sequence accepts from 1 byte up to 256 consecutive bytes of data (which is the size of one page) to be programmed in one operation. Programming means that bits can either be left at 0, or programmed from 1 to 0. Changing bits from 0 to 1 requires an erase operation. Before this can be applied, the bytes of the memory need to be first erased to all 1's (FFh) before any programming.

### 7.2 Sector Erase / Bulk Erase

The Sector Erase (SE) and Bulk Erase (BE) commands set all the bits in a sector or the entire memory array to 1. While bits can be individually programmed from a 1 to 0, erasing bits from 0 to 1 must be done on a sector-wide (SE) or array-wide (BE) level. Before this can be applied, the memory array need to be first erased to all 1's (FFh) before any programming.

### 7.3 Monitoring Write Operations Using the Status Register

The host system can determine when a Write Status Register, program, or erase operation is complete by monitoring the Write in Progress (WIP) bit in the Status Register. The Read from Status Register command provides the state of the WIP bit.

### 7.4 Active Power and Standby Power Modes

The device is enabled and in the Active Power mode when Chip Select (CS#) is Low. When CS# is high, the device is disabled, but may still be in the Active Power mode until all program, erase, and Write Status Register operations have completed. The device then goes into the Standby Power mode, and power consumption drops to  $I_{SB}$ . The Deep Power Down (DP) command provides additional data protection against inadvertent signals. After writing the DP command, the device ignores any further program or erase commands, and reduces its power consumption to  $I_{DP}$ .

### 7.5 Status Register

The Status Register contains the status and control bits that can be read or set by specific commands (see Table [Table 11.6, Command Definitions on page 38](#)):

- **Write In Progress (WIP):** Indicates whether the device is performing a Write Status Register, program or erase operation.
- **Write Enable Latch (WEL):** Indicates the status of the internal Write Enable Latch.
- **Block Protect (BP2, BP1, BP0 for uniform 256 KB sector product: BP3, BP2, BP1, BP0 for uniform 64 KB sector product):** Non-volatile bits that define memory area to be software-protected against program and erase commands.
- **Status Register Write Disable (SRWD):** Places the device in the Hardware Protected mode when this bit is set to 1 and the WP#/ACC input is driven low. In this mode, the non-volatile bits of the Status Register (SRWD, BP3, BP2, BP1, BP0) become read-only bits.

### 7.6 Data Protection Modes

Spansion SPI Flash memory devices provide the following data protection methods:

- **The Write Enable (WREN) command:** Must be written prior to any command that modifies data. The WREN command sets the Write Enable Latch (WEL) bit. The WEL bit resets (disables writes) on *power-up* or after the device completes the following *commands*:
  - Page Program (PP)

- Sector Erase (SE)
- Bulk Erase (BE)
- Write Disable (WRDI)
- Write Status Register (WRSR)

- **Software Protected Mode (SPM):** The Block Protect (BP2, BP1, BP0 for uniform 256 KB sector product; BP3, BP2, BP1, BP0 for uniform 64 KB sector product) bits define the section of the memory array that can be read but not programmed or erased. [Table 7.1](#) shows the sizes and address ranges of protected areas that are defined by Status Register bits BP2:BP0 for uniform 256 KB sector product, BP3:BP0 for uniform 64 KB sector product).
- **Hardware Protected Mode (HPM):** The Write Protect (WP#/ACC) input and the Status Register Write Disable (SRWD) bit together provide write protection.
- **Clock Pulse Count:** The device verifies that all program, erase, and Write Status Register commands consist of a clock pulse count that is a multiple of eight before executing them.

**Table 7.1** S25FL128P Protected Area Sizes (Uniform 256 KB sector)

Status Register Block Protect Bits			Memory Array				Protected Portion of Total Memory Area
BP2	BP1	BP0	Protected Address Range	Protected Sectors	Unprotected Address Range	Unprotected Sectors	
0	0	0	None	(0)	000000h-FFFFFFh	(64) SA63:SA0	0
0	0	1	FC0000h-FFFFFFh	(1) SA63	000000h-FBFFFFh	(32) SA62:SA0	1/64
0	1	0	F80000h-FFFFFFh	(2) SA63:SA62	000000h-F7FFFFh	(16) SA61:SA0	1/32
0	1	1	F00000h-FFFFFFh	(4) SA63:SA60	000000h-EFFFFFh	(8) SA59:SA0	1/16
1	0	0	E00000h-FFFFFFh	(8) SA63:SA56	000000h-DFFFFFh	(4) SA55:SA0	1/8
1	0	1	C00000h-FFFFFFh	(16) SA63:SA48	000000h-BFFFFFh	(2) SA47:SA0	1/4
1	1	0	800000h-FFFFFFh	(32) SA63:SA32	000000h-7FFFFFh	(1) SA31:SA0	1/2
1	1	1	000000h-FFFFFFh	(64) SA63:SA0	None	(0)	All

**Table 7.2** S25FL128P Protected Area Sizes (Uniform 64 KB sector)

Status Register Block Protect Bits				Memory Array				Protected Portion of Total Memory Area
BP3	BP2	BP1	BP0	Protected Address Range	Protected Sectors	Unprotected Address Range	Unprotected Sectors	
0	0	0	0	None	(0)	000000h-FFFFFFh	(256) SA255:SA0	0
0	0	0	1	FE0000h-FFFFFFh	(2) SA255:SA254	000000h-FDFFFFh	(128) SA253:SA0	1/128
0	0	1	0	FC0000h-FFFFFFh	(4) SA255:SA252	000000h-FBFFFFh	(64) SA251:SA0	1/64
0	0	1	1	F80000h-FFFFFFh	(8) SA255:SA248	000000h-F7FFFFh	(32) SA247:SA0	1/32
0	1	0	0	F00000h-FFFFFFh	(16) SA255:SA240	000000h-EFFFFFh	(16) SA239:SA0	1/16
0	1	0	1	E00000h-FFFFFFh	(32) SA255:SA224	000000h-DFFFFFh	(8) SA223:SA0	1/8
0	1	1	0	C00000h-FFFFFFh	(64) SA255:SA192	000000h-BFFFFFh	(4) SA191:SA0	1/4
0	1	1	1	800000h-FFFFFFh	(128) SA255:SA128	000000h-7FFFFFh	(2) SA127:SA0	1/2
1	0	0	0	000000h-FFFFFFh	(256) SA255:SA0	None	(0)	All
1	0	0	1	000000h-FFFFFFh	(256) SA255:SA0	None	(0)	All
1	0	1	0	000000h-FFFFFFh	(256) SA255:SA0	None	(0)	All
1	0	1	1	000000h-FFFFFFh	(256) SA255:SA0	None	(0)	All
1	1	0	0	000000h-FFFFFFh	(256) SA255:SA0	None	(0)	All
1	1	0	1	000000h-FFFFFFh	(256) SA255:SA0	None	(0)	All
1	1	1	0	000000h-FFFFFFh	(256) SA255:SA0	None	(0)	All
1	1	1	1	000000h-FFFFFFh	(256) SA255:SA0	None	(0)	All

## 7.7 Hold Mode (HOLD#)

The Hold input (HOLD#) stops any serial communication with the device, but does not terminate any Write Status Register, program or erase operation that is currently in progress.

The Hold mode starts on the falling edge of HOLD# if SCK is also low (see [Figure 7.1 on page 14](#), standard use). If the falling edge of HOLD# does not occur while SCK is low, the Hold mode begins after the next falling edge of SCK (non-standard use).

The Hold mode ends on the rising edge of HOLD# signal (standard use) if SCK is also low. If the rising edge of HOLD# does not occur while SCK is low, the Hold mode ends on the next falling edge of CLK (non-standard use) See [Figure 7.1](#).

The SO output is high impedance, and the SI and SCK inputs are ignored (don't care) for the duration of the Hold mode.

CS# must remain low for the entire duration of the Hold mode to ensure that the device internal logic remains unchanged. If CS# goes high while the device is in the Hold mode, the internal logic is reset. To prevent the device from reverting to the Hold mode when device communication is resumed, HOLD# must be held high, followed by driving CS# low.

**Figure 7.1** Hold Mode Operation

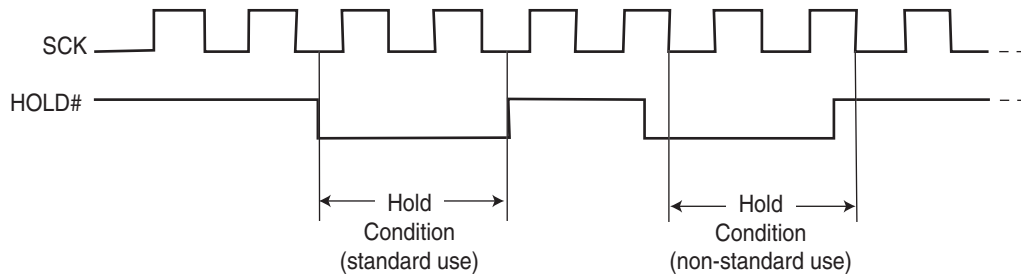

## 8. Sector Address Table

[Table 8.1](#) shows the size of the memory array, sectors, and pages. The device uses *pages* to cache the program data before the data is programmed into the memory array. Each page or byte can be individually programmed (bits are changed from 1 to 0). The data is erased (bits are changed from 0 to 1) on a sector- or device-wide basis using the SE or BE commands. [Table 8.2](#) shows the starting and ending address for each sector. The complete set of sectors comprises the memory array of the Flash device.

**Table 8.1** S25FL128P Device Organization

Each Device has	Each Sector has	Each Page has	
16,777,216	262144 (256 KB sector) 65536 (64 KB sector)	256	bytes
65,536	1024 (256 KB sector) 256 (64 KB sector)	—	pages
64 (256 KB sector) 256 (64 KB sector)	—	—	sectors

Table 8.2 S25FL128P Sector Address Table (Uniform 256 KB sector)

Sector	Address Range		Sector	Address Range	
63	FC0000h	FFFFFFh	31	7C0000h	7FFFFFFh
62	F80000h	FBFFFFh	30	780000h	7BFFFFh
61	F40000h	F7FFFFh	29	740000h	77FFFFh
60	F00000h	F3FFFFh	28	700000h	73FFFFh
59	EC0000h	EFFFFFFh	27	6C0000h	6FFFFFFh
58	E80000h	EBFFFFh	26	680000h	6BFFFFh
57	E40000h	E7FFFFh	25	640000h	67FFFFh
56	E00000h	E3FFFFh	24	600000h	63FFFFh
55	DC0000h	DFFFFFFh	23	5C0000h	5FFFFFFh
54	D80000h	DBFFFFh	22	580000h	5BFFFFh
53	D40000h	D7FFFFh	21	540000h	57FFFFh
52	D00000h	D3FFFFh	20	500000h	53FFFFh
51	CC0000h	CFFFFFFh	19	4C0000h	4FFFFFFh
50	C80000h	CBFFFFh	18	480000h	4BFFFFh
49	C40000h	C7FFFFh	17	440000h	47FFFFh
48	C00000h	C3FFFFh	16	400000h	43FFFFh
47	BC0000h	BFFFFFFh	15	3C0000h	3FFFFFFh
46	B80000h	BBFFFFh	14	380000h	3BFFFFh
45	B40000h	B7FFFFh	13	340000h	37FFFFh
44	B00000h	B3FFFFh	12	300000h	33FFFFh
43	AC0000h	AFFFFFFh	11	2C0000h	2FFFFFFh
42	A80000h	ABFFFFh	10	280000h	2BFFFFh
41	A40000h	A7FFFFh	9	240000h	27FFFFh
40	A00000h	A3FFFFh	8	200000h	23FFFFh
39	9C0000h	9FFFFFFh	7	1C0000h	1FFFFFFh
38	980000h	9BFFFFh	6	180000h	1BFFFFh
37	940000h	97FFFFh	5	140000h	17FFFFh
36	900000h	93FFFFh	4	100000h	13FFFFh
35	8C0000h	8FFFFFFh	3	0C0000h	0FFFFFFh
34	880000h	8BFFFFh	2	080000h	0BFFFFh
33	840000h	87FFFFh	1	040000h	07FFFFh
32	800000h	83FFFFh	0	000000h	03FFFFh

**Table 8.3** S25FL128P Sector Address Table (Uniform 64 KB sector) (Sheet 1 of 2)

Sector	Address Range		Sector	Address Range		Sector	Address Range	
255	FF0000h	FFFFFFh	207	CF0000h	CFFFFFFh	159	9F0000h	9FFFFFFh
254	FE0000h	FEFFFFh	206	CE0000h	CEFFFFh	158	9E0000h	9EFFFFh
253	FD0000h	FDFFFFh	205	CD0000h	CDFFFFh	157	9D0000h	9DFFFFh
252	FC0000h	FCFFFFh	204	CC0000h	CCFFFFh	156	9C0000h	9CFFFFh
251	FB0000h	FBFFFFh	203	CB0000h	CBFFFFh	155	9B0000h	9BFFFFh
250	FA0000h	FAFFFFh	202	CA0000h	CAFFFFh	154	9A0000h	9AFFFFh
249	F90000h	F9FFFFh	201	C90000h	C9FFFFh	153	990000h	99FFFFh
248	F80000h	F8FFFFh	200	C80000h	C8FFFFh	152	980000h	98FFFFh
247	F70000h	F7FFFFh	199	C70000h	C7FFFFh	151	970000h	97FFFFh
246	F60000h	F6FFFFh	198	C60000h	C6FFFFh	150	960000h	96FFFFh
245	F50000h	F5FFFFh	197	C50000h	C5FFFFh	149	950000h	95FFFFh
244	F40000h	F4FFFFh	196	C40000h	C4FFFFh	148	940000h	94FFFFh
243	F30000h	F3FFFFh	195	C30000h	C3FFFFh	147	930000h	93FFFFh
242	F20000h	F2FFFFh	194	C20000h	C2FFFFh	146	920000h	92FFFFh
241	F10000h	F1FFFFh	193	C10000h	C1FFFFh	145	910000h	91FFFFh
240	F00000h	F0FFFFh	192	C00000h	C0FFFFh	144	900000h	90FFFFh
239	EF0000h	EFFFFFh	191	BF0000h	BFFFFFFh	143	8F0000h	8FFFFFFh
238	EE0000h	EEFFFFh	190	BE0000h	BEFFFFh	142	8E0000h	8EFFFFh
237	ED0000h	EDFFFFh	189	BD0000h	BDFFFFh	141	8D0000h	8DFFFFh
236	EC0000h	ECFFFFh	188	BC0000h	BCFFFFh	140	8C0000h	8CFFFFh
235	EB0000h	EBFFFFh	187	BB0000h	BBFFFFh	139	8B0000h	8BFFFFh
234	EA0000h	EAFFFFh	186	BA0000h	BAFFFFh	138	8A0000h	8AFFFFh
233	E90000h	E9FFFFh	185	B90000h	B9FFFFh	137	890000h	89FFFFh
232	E80000h	E8FFFFh	184	B80000h	B8FFFFh	136	880000h	88FFFFh
231	E70000h	E7FFFFh	183	B70000h	B7FFFFh	135	870000h	87FFFFh
230	E60000h	E6FFFFh	182	B60000h	B6FFFFh	134	860000h	86FFFFh
229	E50000h	E5FFFFh	181	B50000h	B5FFFFh	133	850000h	85FFFFh
228	E40000h	E4FFFFh	180	B40000h	B4FFFFh	132	840000h	84FFFFh
227	E30000h	E3FFFFh	179	B30000h	B3FFFFh	131	830000h	83FFFFh
226	E20000h	E2FFFFh	178	B20000h	B2FFFFh	130	820000h	82FFFFh
225	E10000h	E1FFFFh	177	B10000h	B1FFFFh	129	810000h	81FFFFh
224	E00000h	E0FFFFh	176	B00000h	B0FFFFh	128	800000h	80FFFFh
223	DF0000h	DFFFFFh	175	AF0000h	AFFFFFFh	127	7F0000h	7FFFFFFh
222	DE0000h	DEFFFFh	174	AE0000h	AFFFFFFh	126	7E0000h	7EFFFFh
221	DD0000h	DDFFFFh	173	AD0000h	ADFFFFh	125	7D0000h	7DFFFFh
220	DC0000h	DCFFFFh	172	AC0000h	ACFFFFh	124	7C0000h	7CFFFFh
219	DB0000h	DBFFFFh	171	AB0000h	ABFFFFh	123	7B0000h	7BFFFFh
218	DA0000h	DAFFFFh	170	AA0000h	AAFFFFh	122	7A0000h	7AFFFFh
217	D90000h	D9FFFFh	169	A90000h	A9FFFFh	121	790000h	79FFFFh
216	D80000h	D8FFFFh	168	A80000h	A8FFFFh	120	780000h	78FFFFh
215	D70000h	D7FFFFh	167	A70000h	A7FFFFh	119	770000h	77FFFFh
214	D60000h	D6FFFFh	166	A60000h	A6FFFFh	118	760000h	76FFFFh
213	D50000h	D5FFFFh	165	A50000h	A5FFFFh	117	750000h	75FFFFh
212	D40000h	D4FFFFh	164	A40000h	A4FFFFh	116	740000h	74FFFFh
211	D30000h	D3FFFFh	163	A30000h	A3FFFFh	115	730000h	73FFFFh
210	D20000h	D2FFFFh	162	A20000h	A2FFFFh	114	720000h	72FFFFh
209	D10000h	D1FFFFh	161	A10000h	A1FFFFh	113	710000h	71FFFFh
208	D00000h	D0FFFFh	160	A00000h	A0FFFFh	112	700000h	70FFFFh



Table 8.3 S25FL128P Sector Address Table (Uniform 64 KB sector) (Sheet 2 of 2)

Sector	Address Range		Sector	Address Range		Sector	Address Range	
111	6F0000h	6FFFFFFh	71	470000h	47FFFFFFh	31	1F0000h	1FFFFFFh
110	6E0000h	6EFFFFFFh	70	460000h	46FFFFFFh	30	1E0000h	1EFFFFFFh
109	6D0000h	6DFFFFFFh	69	450000h	45FFFFFFh	29	1D0000h	1DFFFFFFh
108	6C0000h	6CFFFFFFh	68	440000h	44FFFFFFh	28	1C0000h	1CFFFFFFh
107	6B0000h	6BFFFFFFh	67	430000h	43FFFFFFh	27	1B0000h	1BFFFFFFh
106	6A0000h	6AFFFFFFh	66	420000h	42FFFFFFh	26	1A0000h	1AFFFFFFh
105	690000h	69FFFFFFh	65	410000h	41FFFFFFh	25	190000h	19FFFFFFh
104	680000h	68FFFFFFh	64	400000h	40FFFFFFh	24	180000h	18FFFFFFh
103	670000h	67FFFFFFh	63	3F0000h	3FFFFFFh	23	170000h	17FFFFFFh
102	660000h	66FFFFFFh	62	3E0000h	3EFFFFFFh	22	160000h	16FFFFFFh
101	650000h	65FFFFFFh	61	3D0000h	3DFFFFFFh	21	150000h	15FFFFFFh
100	640000h	64FFFFFFh	60	3C0000h	3CFFFFFFh	20	140000h	14FFFFFFh
99	630000h	63FFFFFFh	59	3B0000h	3BFFFFFFh	19	130000h	13FFFFFFh
98	620000h	62FFFFFFh	58	3A0000h	3AFFFFFFh	18	120000h	12FFFFFFh
97	610000h	61FFFFFFh	57	390000h	39FFFFFFh	17	110000h	11FFFFFFh
96	600000h	60FFFFFFh	56	380000h	38FFFFFFh	16	100000h	10FFFFFFh
95	5F0000h	5FFFFFFh	55	370000h	37FFFFFFh	15	0F0000h	0FFFFFFh
94	5E0000h	5EFFFFFFh	54	360000h	36FFFFFFh	14	0E0000h	0EFFFFFFh
93	5D0000h	5DFFFFFFh	53	350000h	35FFFFFFh	13	0D0000h	0DFFFFFFh
92	5C0000h	5CFFFFFFh	52	340000h	34FFFFFFh	12	0C0000h	0CFFFFFFh
91	5B0000h	5BFFFFFFh	51	330000h	33FFFFFFh	11	0B0000h	0BFFFFFFh
90	5A0000h	5AFFFFFFh	50	320000h	32FFFFFFh	10	0A0000h	0AFFFFFFh
89	590000h	59FFFFFFh	49	310000h	31FFFFFFh	9	090000h	09FFFFFFh
88	580000h	58FFFFFFh	48	300000h	30FFFFFFh	8	080000h	08FFFFFFh
87	570000h	57FFFFFFh	47	2F0000h	2FFFFFFh	7	070000h	07FFFFFFh
86	560000h	56FFFFFFh	46	2E0000h	2EFFFFFFh	6	060000h	06FFFFFFh
85	550000h	55FFFFFFh	45	2D0000h	2DFFFFFFh	5	050000h	05FFFFFFh
84	540000h	54FFFFFFh	44	2C0000h	2CFFFFFFh	4	040000h	04FFFFFFh
83	530000h	53FFFFFFh	43	2B0000h	2BFFFFFFh	3	030000h	03FFFFFFh
82	520000h	52FFFFFFh	42	2A0000h	2AFFFFFFh	2	020000h	02FFFFFFh
81	510000h	51FFFFFFh	41	290000h	29FFFFFFh	1	010000h	01FFFFFFh
80	500000h	50FFFFFFh	40	280000h	28FFFFFFh	0	000000h	00FFFFFFh
79	4F0000h	4FFFFFFh	39	270000h	27FFFFFFh			
78	4E0000h	4EFFFFFFh	38	260000h	26FFFFFFh			
77	4D0000h	4DFFFFFFh	37	250000h	25FFFFFFh			
76	4C0000h	4CFFFFFFh	36	240000h	24FFFFFFh			
75	4B0000h	4BFFFFFFh	35	230000h	23FFFFFFh			
74	4A0000h	4AFFFFFFh	34	220000h	22FFFFFFh			
73	490000h	49FFFFFFh	33	210000h	21FFFFFFh			
72	480000h	48FFFFFFh	32	200000h	20FFFFFFh			

## 9. Parallel Mode (for 16-pin SO package only)

The parallel mode provides 8 bits of input/output to increase factory production throughput at the customer manufacturing facilities. This function is recommended for increasing production throughput. Entering Parallel mode requires issuing the Enter Parallel Mode command (55h). After writing the Parallel Mode Entry command and pulling CS# high, the available commands are Read, Write Enable (WREN), Write Disable (WRDI), Page Program (PP), Sector Erase (SE), Bulk Erase (BE), Write Status Register (WRSR), Read Status Register (RDSR), Release from Deep Power Down/Release from Deep Power Down and Read Electronic Signature (RES), Write Enable (WREN), Write Disable (WRDI), Deep Power Down (DP), Read Identification (RDID) and Read ID (READ\_ID).

The flash memory will remain in Parallel mode until either the Parallel Mode Exit command (45h) is issued, or until a power-down / power-up sequence has been completed, after which the flash memory will exit parallel mode automatically and switch back to serial mode (no power-down will be necessary to switch back to serial mode if the Parallel Mode Exit command is issued).

In parallel mode, the maximum SCK clock frequency is limited to 6 MHz for Read Data Bytes and 10 MHz for other operations. PO[6-0] can be left unconnected if the Parallel Mode functions are not needed. Fast-Read command is not applicable in Parallel mode.

## 10. Accelerated Programming Operation

The device offers accelerated program operations through the ACC function. This function is primarily intended to allow faster manufacturing throughput at the factory. If the system asserts  $V_{HH}$  on this pin, the device uses the higher voltage on the pin to reduce the time required for program operations. Removing  $V_{HH}$  from the WP#/ACC pin returns the device to normal operation. Note that the WP#/ACC pin must not be at  $V_{HH}$  for operations other than accelerated programming, or device damage may result. In addition, the WP#/ACC pin must not be left floating or unconnected; inconsistent behavior of the device may result.

## 11. Command Definitions

The host system must shift all commands, addresses, and data in and out of the device, beginning with the most significant bit. On the first rising edge of SCK after CS# is driven low, the device accepts the one-byte command on SI (all commands are one byte long), most significant bit first. Each successive bit is latched on the rising edge of SCK. [Table 11.6 on page 38](#) lists the complete set of commands.

Every command sequence begins with a one-byte command code. The command may be followed by address, data, both, or nothing, depending on the command. CS# must be driven high after the last bit of the command sequence has been written.

The Read Data Bytes (READ), Read Status Register (RDSR), Read Data Bytes at Higher Speed (FAST\_READ) and Read Identification (RDID) command sequences are followed by a data output sequence on SO. CS# can be driven high after any bit of the sequence is output to terminate the operation.

The Page Program (PP), Sector Erase (SE), Bulk Erase (BE), Write Status Register (WRSR), Write Enable (WREN), or Write Disable (WRDI) commands require that CS# be driven high at a byte boundary, otherwise the command is not executed. Since a byte is composed of eight bits, CS# must therefore be driven high when the number of clock pulses after CS# is driven low is an exact multiple of eight.

The device ignores any attempt to access the memory array during a Write Status Register, program, or erase operation, and continues the operation uninterrupted.

### 11.1 Read Data Bytes (READ: 03h)

#### 11.1.1 Serial Mode

The Read Data Bytes (READ-Serial Mode) command reads data from the memory array at the frequency ( $f_{SCK}$ ) presented at the SCK input, with a maximum speed of 40 MHz. The host system must first select the device by driving CS# low. The READ command is then written to SI, followed by a 3-byte address (A23-A0). Each bit is latched on the rising edge of SCK. The memory array data, at that address, are output serially on SO at a frequency  $f_{SCK}$ , on the falling edge of SCK.

[Figure 11.1](#) and [Table 11.6](#) detail the READ command sequence. The first byte specified can be at any location. The device automatically increments to the next higher address after each byte of data is output. The entire memory array can therefore be read with a single READ command. When the highest address is reached, the address counter reverts to 00000h, allowing the read sequence to continue indefinitely.

The READ command is terminated by driving CS# high at any time during data output. The device rejects any READ command issued while it is executing a program, erase, or Write Status Register operation, and continues the operation uninterrupted.

**Figure 11.1** Read Data Bytes (READ) Command Sequence

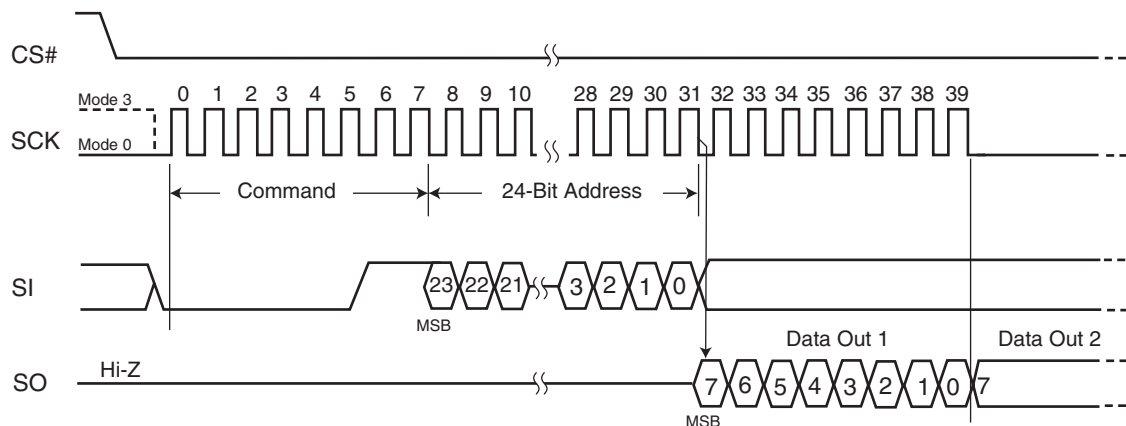

### 11.1.2 Parallel Mode

In parallel mode, the maximum SCK clock frequency is 6 MHz. The device requires a single clock cycle instead of eight clock cycles to access the next data byte. The memory array output will be the same as in the serial mode. The only difference is that a byte of data is output per clock cycle instead of a single bit. This means that 256 bytes of data can be copied into the 256 byte wide page write buffer in 256 clock cycles instead of in 2,048 clock cycles.

Figure 11.2 Parallel Read Instruction Sequence

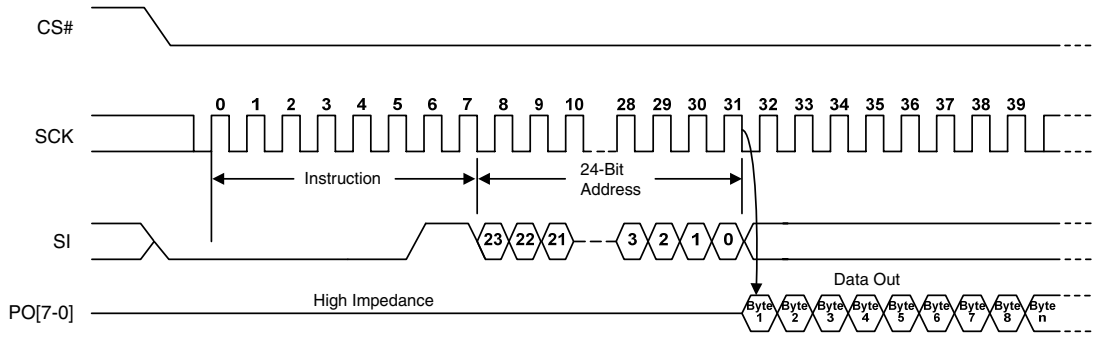

**Notes**

1. 1st Byte = "03h".
2. 2nd Byte = Address 1, MSB first (bits 23 through 16).
3. 3rd Byte = Address 2, MSB first (bits 15 through 8).
4. 4th Byte = Address 3, MSB first (bits 7 through 0).
5. From the 5th Byte, SO will output the array data.
6. In parallel mode, the maximum clock frequency (Fsck) is 6 MHz.
7. For parallel mode operation, the device requires an Enter Parallel Mode command (55h) before the READ command. An Exit Parallel Mode (45h) command or a power-down / power-up sequence is required to exit the parallel mode.

## 11.2 Read Data Bytes at Higher Speed (FAST\_READ: 0Bh)

The FAST\_READ command reads data from the memory array at the frequency ( $f_{SCK}$ ) presented at the SCK input, with a maximum speed of 104 MHz. The host system must first select the device by driving CS# low. The FAST\_READ command is then written to SI, followed by a 3-byte address (A23-A0) and a dummy byte. Each bit is latched on the rising edge of SCK. The memory array data, at that address, are output serially on SO at a frequency  $f_{SCK}$ , on the falling edge of SCK.

The FAST\_READ command sequence is shown in Figure 11.3 and Table 11.6. The first byte specified can be at any location. The device automatically increments to the next higher address after each byte of data is output. The entire memory array can therefore be read with a single FAST\_READ command. When the highest address is reached, the address counter reverts to 00000h, allowing the read sequence to continue indefinitely.

The FAST\_READ command is terminated by driving CS# high at any time during data output. The device rejects any FAST\_READ command issued while it is executing a program, erase, or Write Status Register operation, and continues the operation uninterrupted. Note that the FAST\_READ command is not valid in parallel mode.

**Figure 11.3** Read Data Bytes at Higher Speed (FAST\_READ) Command Sequence

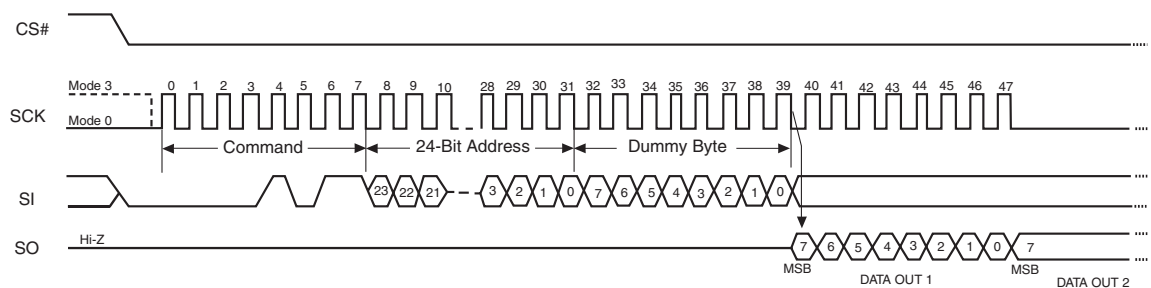

### 11.3 Read Identification (RDID: 9Fh)

#### 11.3.1 Serial Mode

The Read Identification (RDID) instruction opcode allows the 8-bit manufacturer identification to be read, follow by two bytes of device identification. The manufacturer identification is assigned by JEDEC. The device identification is assigned by the device manufacturer.

Any Read Identification (RDID) instruction opcode issued while a program, erase, or write cycle is in progress is not decoded and has no effect on execution of the program, erase, or write cycle that is in progress.

The device is first selected by driving the CS# chip select input pin to the logic low state. After this, the RDID 8-bit instruction opcode is shifted in onto the SI serial input pin. After the last bit of the RDID instruction opcode is shifted into the device, a byte of manufacturer identification, two bytes of device identification and two bytes of extended device identification will be shifted sequentially out of the SO serial output pin. Each bit is shifted out during the falling edge of the SCK serial clock signal. The maximum clock frequency for the RDID (9Fh) command is at 40MHz (Normal Read).

The Read Identification (RDID) instruction sequence is terminated by driving the CS# chip select input pin to the logic high state anytime during data output. After issuing any Read ID instruction opcodes (90h, 9Fh, ABh), driving the CS# chip select input pin to the logic high state will automatically send the device into the standby mode. Driving the CS# chip select input pin to the logic low state again will automatically send the device out of the standby mode and into the active mode.

**Figure 11.4** Read Identification Command Sequence and Data Out Sequence

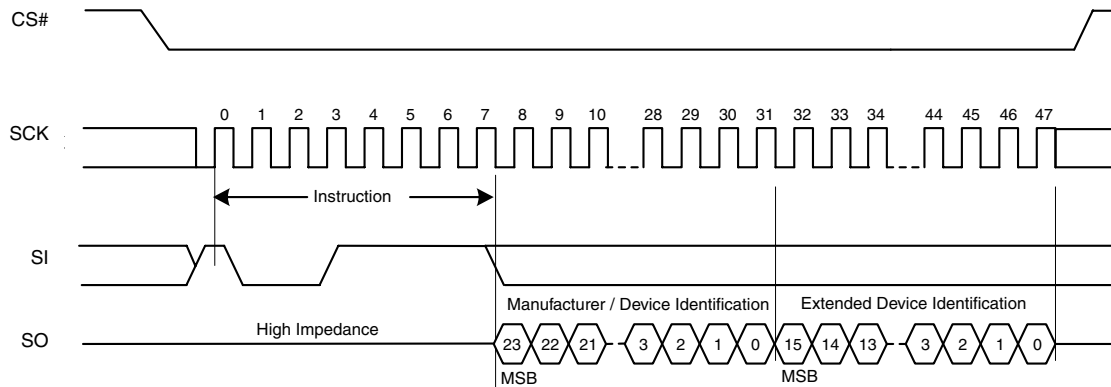

### 11.3.2 Parallel Mode

In parallel mode, the maximum SCK clock frequency is 10 MHz. The device requires a single clock cycle instead of eight clock cycles to access the next data byte. The method of memory content output will be the same compared to the serial mode. The only difference is that a byte of data is output per clock cycle instead of a single bit. In this case, the manufacturer identification will be output during the first byte cycle and the device identification during the second and third byte cycles out of the PO7-PO0 serial output pins. To read ID in parallel mode requires a Parallel Mode Entry command (55h) to be issued before the RDID command. Once in the parallel mode, the flash memory will not exit parallel mode until a Parallel Mode Exit (45h) command is given to the flash device, or upon power down/power up sequence.

**Figure 11.5** Parallel Read\_ID Command Sequence and Data Out Sequence

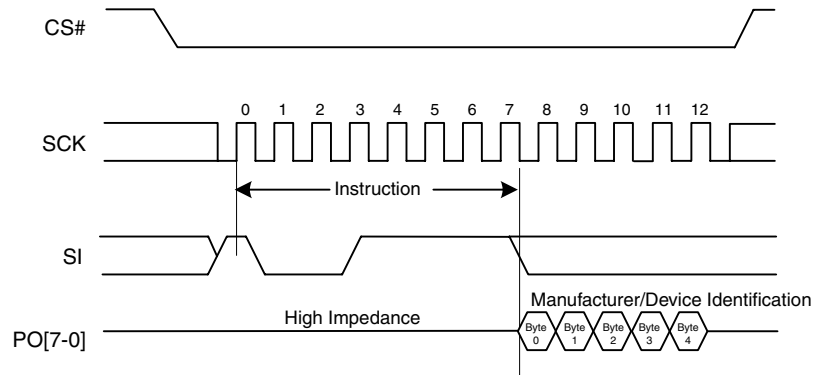

**Table 11.1** Manufacturer & Device Identification, RDID (9Fh)

Device	Manufacturer Identification		Device Identification		Extended Device Identification	
	Byte 0	Byte 1	Byte 2	Byte 3	Byte 4	Byte 5
Uniform 256 KB Sector	01h	20h	18h	03h	00h	
Uniform 64 KB Sector	01h	20h	18h	03h	01h	

## 11.4 Read Manufacturer and Device ID (READ\_ID: 90h)

### 11.4.1 Serial Mode

The READ\_ID (90h) instruction identifies the Device Manufacturer ID and the Device ID. The instruction is initiated by driving the CS# pin low and shifting in (via the SI input pin) the instruction code “90h” followed by a 24-bit address of XXXXX0h. (X: High or Low) Following this, the Manufacturer ID and the Device ID are shifted out on SO output pin starting after the falling edge of the SCK serial clock input signal. The Manufacturer ID and the Device ID are always shifted out on the SO output pin with the MSB first, as shown in Figure 11.6. If the 24-bit address is set to XXXXX1h, then the Device ID is read out first followed by the Manufacturer ID. Note that the upper 23 bits of the address do not have to be 0’s and can be don’t cares. Once the device is in READ\_ID mode, the Manufacturer ID and Device ID output data toggles between address 000000H and 000001H until terminated by a low to high transition on the CS# input pin. After the first 24-bit address is provided, the user must wait 16 clock cycles for both the Manufacturer ID and Device ID to be output on the SO output pin. The maximum clock frequency for the READ\_ID (90h) command is at 104MHz (Fast Read). Parallel Mode the maximum clock frequency is 10Mhz.

The Manufacturer ID & Device ID is output continuously until terminated by a low to high transition on CS# chip select input pin.

After issuing READ\_ID instruction, driving the CS# chip select input pin to the logic high state will automatically send the device into the standby mode. Driving the CS# chip select input pin to the logic low state again will automatically sent the device out of the standby mode and into the active mode.

Figure 11.6 Serial READ\_ID Instruction Sequence

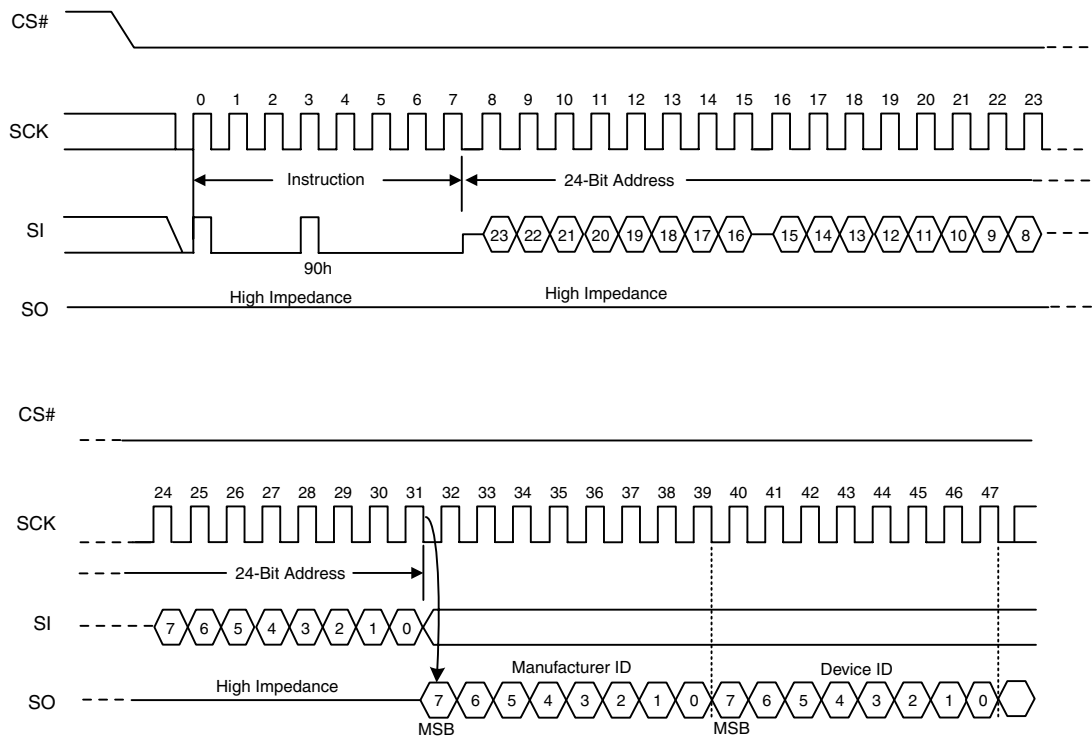



### 11.4.2 Parallel Mode

The maximum clock frequency allowed on the SCK input pin in parallel mode is 10 MHz. The Parallel Mode Entry command (55h) must be issued before writing the READ\_ID command. Once in the parallel mode, the flash memory will not exit parallel mode until a Parallel Mode Exit (45h) command is given to the flash device, or upon power-down/power-up sequence.

Figure 11.7 Parallel Read\_ID Instruction Sequence

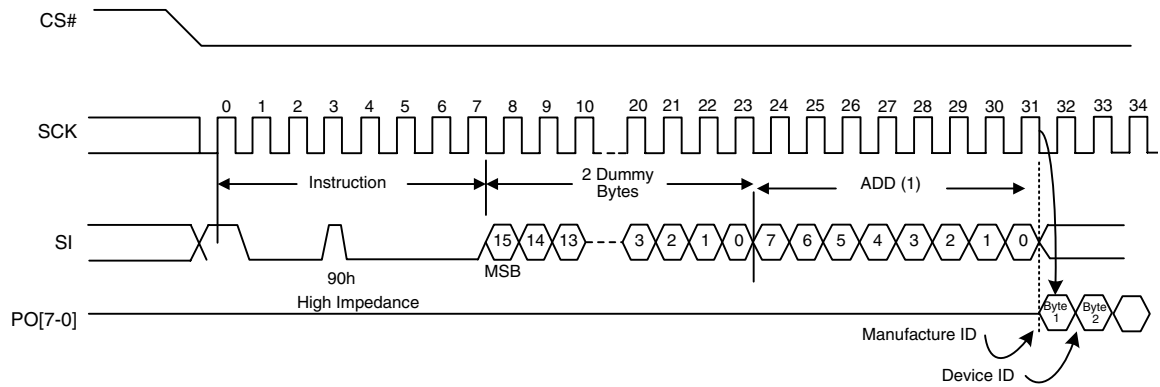

Table 11.2 READ\_ID Command and Data

Description	Address	Data
Manufacturer Identification	00000h	01h
Device Identification (Memory Capacity)	00001h	17h

### 11.5 Write Enable (WREN: 06h)

The Write Enable (WREN) command (see Figure 11.8) sets the Write Enable Latch (WEL) bit to a 1, which enables the device to accept a Write Status Register, program, or erase command. The WEL bit must be set prior to every Page Program (PP), Erase (SE or BE) and Write Status Register (WRSR) command.

The host system must first drive CS# low, write the WREN command, and then drive CS# high.

Figure 11.8 Write Enable (WREN) Command Sequence

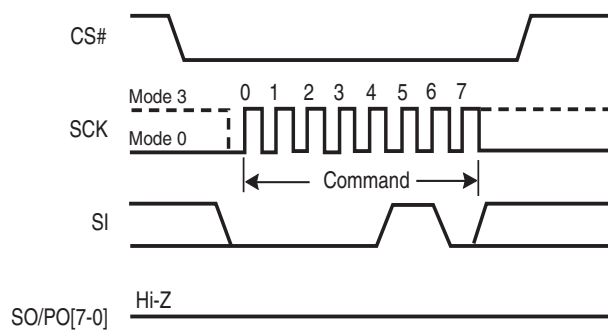

## 11.6 Write Disable (WRDI: 04h)

The Write Disable (WRDI) command (see [Figure 11.9](#)) resets the Write Enable Latch (WEL) bit to a 0, which disables the device from accepting a Write Status Register, program, or erase command. The host system must first drive CS# low, write the WRDI command, and then drive CS# high.

Any of following conditions resets the WEL bit:

- Power-up
- Write Disable (WRDI) command completion
- Write Status Register (WRSR) command completion
- Page Program (PP) command completion
- Sector Erase (SE) command completion
- Bulk Erase (BE) command completion

**Figure 11.9** Write Disable (WRDI) Command Sequence

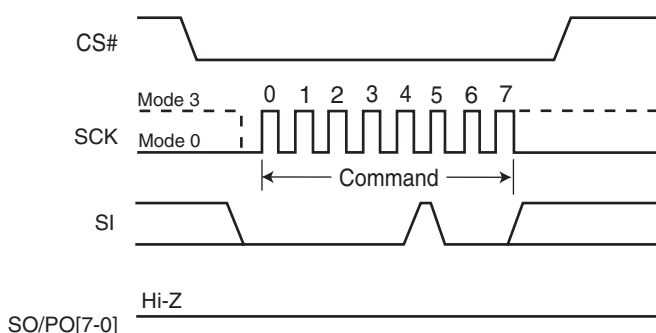

## 11.7 Read Status Register (RDSR: 05h)

### 11.7.1 Serial Mode

The Read Status Register (RDSR) command outputs the state of the Status Register bits. [Table 11.3](#) shows the status register bits and their functions.

The RDSR command may be written at any time, even while a program, erase, or Write Status Register operation is in progress. The host system should check the Write In Progress (WIP) bit before sending a new command to the device if an operation is already in progress. [Figure 11.10](#) shows the RDSR command sequence, which also shows that it is possible to read the Status Register continuously until CS# is driven high.

**Table 11.3** S25FL128P Status Register (Uniform 256 KB sector)

Bit	Status Register Bit	Bit Function	Description
7	SRWD	Status Register Write Disable	1 = Protects when WP#/ACC is low 0 = No protection, even when WP#/ACC is low
6	Don't Care	—	—
5	0	—	Not used
4	BP2	Block Protect	000–111 = Protects upper half of address range in 7 sizes.
3	BP1		
2	BP0		
1	WEL	Write Enable Latch	1 = Device accepts Write Status Register, program, or erase commands 0 = Ignores Write Status Register, program, or erase commands
0	WIP	Write in Progress	1 = Device Busy. A Write Status Register, program, or erase operation is in progress 0 = Ready. Device is in standby mode and can accept commands.

**Table 11.4** S25FL128P Status Register (Uniform 64 KB sector)

Bit	Status Register Bit	Bit Function	Description
7	SRWD	Status Register Write Disable	1 = Protects when WP#/ACC is low 0 = No protection, even when WP#/ACC is low
6	Don't Care	—	—
5	BP3	Block Protect	0000–1111= Protects upper half of address range in 8 sizes.
4	BP2		
3	BP1		
2	BP0		
1	WEL	Write Enable Latch	1 = Device accepts Write Status Register, program, or erase commands 0 = Ignores Write Status Register, program, or erase commands
0	WIP	Write in Progress	1 = Device Busy. A Write Status Register, program, or erase operation is in progress 0 = Ready. Device is in standby mode and can accept commands.

**Figure 11.10** Read Status Register (RDSR) Command Sequence

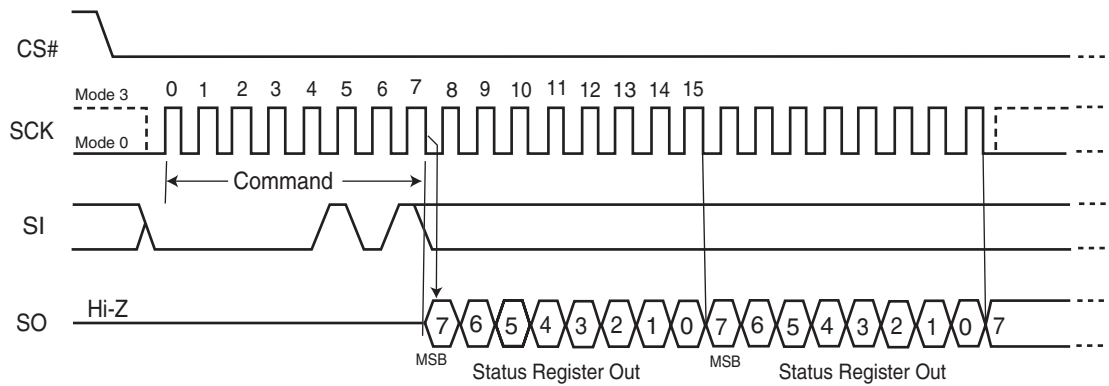

### 11.7.2 Parallel Mode

When the device is in Parallel Mode, the maximum SCK clock frequency is 10 MHz. The device requires a single clock cycle instead of eight clock cycles to access the next data byte. The method of memory content output will be the same compared to outside of Parallel Mode. The only difference is that a byte of data is output per clock cycle instead of a single bit. The Status Register contents can be read out on the PO[7-0] serial output pins continuously by applying multiples of clock cycles.

**Figure 11.11** Parallel Read Status Register (RDSR) Instruction Sequence

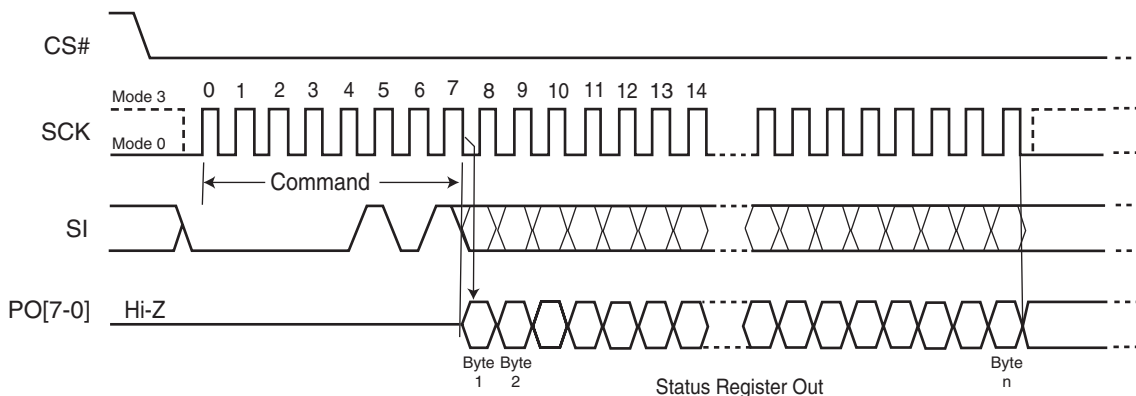

**Notes**

1. Instruction byte = 05h.
2. Under parallel mode, the fastest access clock frequency ( $F_{sck}$ ) will be changed to a maximum of 10MHz (SCK pin clock frequency).
3. To read Status Register in parallel mode requires a Parallel Mode Entry command (55h) to be issued before the RDSR command. Once in the parallel mode, the flash memory will not exit the parallel mode until a Parallel Mode Exit (45h) command is given to the flash device, or upon power down / power up sequence.

### 11.7.3 Status Register Bit Descriptions

The following describes the status and control bits of the Status Register, and applies to both serial and parallel modes.

**Write In Progress (WIP) bit:** Indicates whether the device is busy performing a Write Status Register, program, or erase operation. This bit is read-only, and is controlled internally by the device. If WIP is 1, one of these operations is in progress; if WIP is 0, no such operation is in progress.

**Write Enable Latch (WEL) bit:** Determines whether the device will accept and execute a Write Status Register, program, or erase command. When set to 1, the device accepts these commands; when set to 0, the device rejects the commands. This bit is set to 1 by writing the WREN command, and set to 0 by the WRDI command, and is also automatically reset to 0 after the completion of a Write Status Register, program, or erase operation. WEL cannot be directly set by the WRSR command.

**Block Protect (BP2, BP1, BP0) bits for uniform 256KB sector product: (BP3, BP2, BP1, BP0) for uniform 64KB sector product:** Define the portion of the memory area that will be protected against any changes to the stored data. The Write Status Register (WRSR) command controls these bits, which are non-volatile. When one or more of these bits is set to 1, the corresponding memory area (see [Table 7.1 on page 13](#)) is protected against Page Program (PP) and Sector Erase (SE) commands. If the Hardware Protected mode is enabled, BP2:BP0 (or BP3:BP0) cannot be changed. The Bulk Erase (BE) command is executed only if all Block Protect bits are 0.

**Status Register Write Disable (SRWD) bit:** Provides data protection when used together with the Write Protect (WP#/ACC) signal. When SRWD is set to 1 and WP#/ACC is driven low, the device enters the Hardware Protected mode. The non-volatile bits of the Status Register (SRWD, BP2, BP1, BP0) become read-only bits and the device ignores any Write Status Register (WRSR) command.

## 11.8 Write Status Register (WRSR: 01h)

The Write Status Register (WRSR) command changes the bits in the Status Register. A Write Enable (WREN) command, which itself sets the Write Enable Latch (WEL) in the Status Register, is required prior to writing the WRSR command. [Table 11.3, S25FL128P Status Register \(Uniform 256 KB sector\) on page 26](#) shows the status register bits and their functions.

The host system must drive CS# low, write the WRSR command, and the appropriate data byte on SI ([Figure 11.12](#)).

The WRSR command cannot change the state of the Write Enable Latch (bit 1). The WREN command must be used for that purpose. Bit 0 is a status bit controlled internally by the Flash device. Bits 6 and 5 are always read as 0 and have no user significance.

The WRSR command also controls the value of the Status Register Write Disable (SRWD) bit. The SRWD bit and WP#/ACC together place the device in the Hardware Protected Mode (HPM). The device ignores all WRSR commands once it enters the Hardware Protected Mode (HPM). [Table 11.5](#) shows that WP#/ACC must be driven low and the SRWD bit must be 1 for this to occur.

**Figure 11.12** Write Status Register (WRSR) Command Sequence

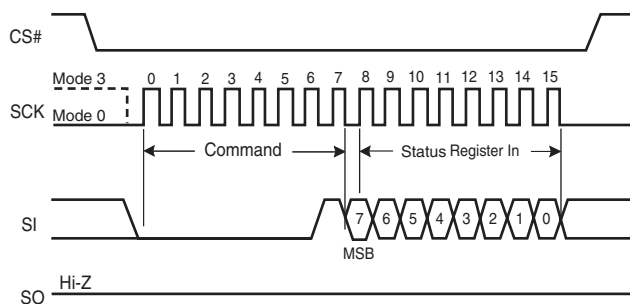

**Figure 11.13** Parallel Write Status Register (WRSR) Command Sequence

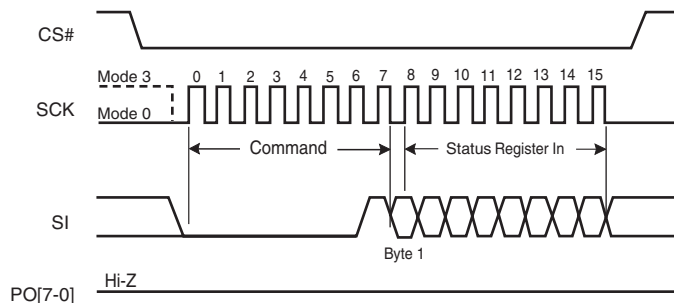

### Notes

1. Instruction byte = 01h
2. In parallel mode, the maximum access clock frequency ( $F_{sck}$ ) is 10 MHz (SCK pin clock frequency).
3. Writing to the Status Register in parallel mode requires a Parallel Mode Entry command (55h) to be issued before the RDSR command. Once in the parallel mode, the flash memory will not exit the parallel mode until a Parallel Mode Exit (45h) command is given to the flash device, or upon power-down or power-up sequence.

**Table 11.5** Protection Modes

WP#/ACC Signal	SRWD Bit	Mode	Write Protection of the Status Register	Protected Area (See Note)	Unprotected Area (See Note)
1	1	Software Protected (SPM)	Status Register is writable (if the WREN command has set the WEL bit). The values in the SRWD, BP2, BP1 and BP0 (or BP3, BP2, BP1 and BP0) bits can be changed.	Protected against program and erase commands	Ready to accept Page Program and Sector Erase commands
1	0				
0	0				
0	1	Hardware Protected (HPM)	Status Register is Hardware write protected. The values in the SRWD, BP2, BP1 and BP0 (or BP3, BP2, BP1 and BP0) bits cannot be changed.	Protected against program and erase commands	Ready to accept Page Program and Sector Erase commands

**Note**

As defined by the values in the Block Protect (BP2, BP1, BP0) bits of the Status Register, as shown in [Table 7.1 on page 13](#).

[Table 11.5](#) shows that neither WP#/ACC or SRWD bit by themselves can enable HPM. The device can enter HPM either by setting the SRWD bit after driving WP#/ACC low, or by driving WP#/ACC low after setting the SRWD bit. However, the device disables HPM only when WP#/ACC is driven high.

Note that HPM only protects against changes to the status register. Since BP2:BP0 (or BP3:BP0) cannot be changed in HPM, the size of the protected area of the memory array cannot be changed. Note that HPM provides no protection to the memory array area outside that specified by Block Protect bits (Software Protected Mode, or SPM).

If WP#/ACC is permanently tied high, HPM can never be activated, and only the SPM (Block Protect bits of the Status Register) can be used.

## 11.9 Page Program (PP: 02h)

### 11.9.1 Serial Mode

The Page Program (PP) command changes specified bytes in the memory array (from 1 to 0 only). A WREN command is required prior to writing the PP command.

The host system must drive CS# low, and then write the PP command, three address bytes, and at least one data byte on SI. CS# must be driven low for the entire duration of the PP sequence. The command sequence is shown in [Figure 11.14](#) and [Table 11.6](#).

The device programs only the last 256 data bytes sent to the device. If the number of data bytes exceeds this limit, the bytes sent before the last 256 bytes are discarded, and the device begins programming the last 256 bytes sent at the starting address of the specified page. This may result in data being programmed into different addresses within the same page than expected. If fewer than 256 data bytes are sent to device, they are correctly programmed at the requested addresses.

The host system must drive CS# high after the device has latched the 8th bit of the data byte, otherwise the device does not execute the PP command. The PP operation begins as soon as CS# is driven high. The device internally controls the timing of the operation, which requires a period of  $t_{PP}$ . The Status Register may be read to check the value of the Write In Progress (WIP) bit while the PP operation is in progress. The WIP bit is 1 during the PP operation, and is 0 when the operation is completed. The device internally resets the Write Enable Latch to 0 before the operation completes (the exact timing is not specified).

The device does not execute a Page Program (PP) command that specifies a page that is protected by the Block Protect bits (see [Table 7.1 on page 13](#)).

Figure 11.14 Page Program (PP) Command Sequence

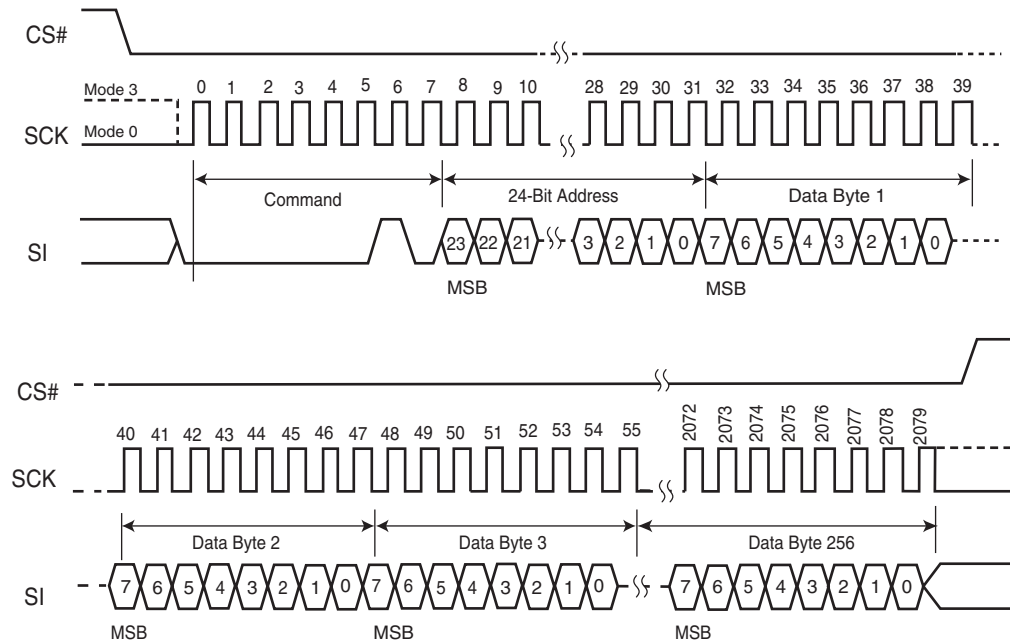

### 11.9.2 Parallel Mode

In parallel mode, the maximum SCK clock frequency is 10 MHz. The device requires a single clock cycle instead of eight clock cycles to access the next data byte. The memory content input method is the same as serial mode. The only difference is that a byte of data is input per clock cycle instead of a single bit. This means that 256 bytes of data can be copied into the 256 byte wide page write buffer in 256 clock cycles instead of in 2,048 clock cycles.

**Figure 11.15** Parallel Page Program (PP) Instruction Sequence

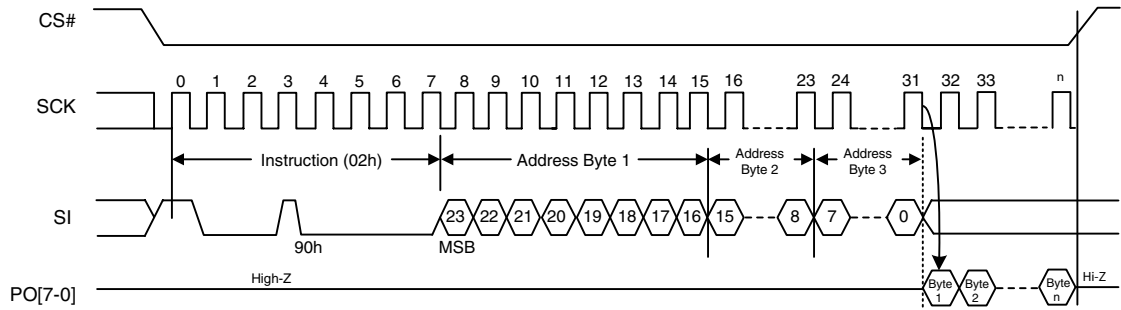

**Notes**

1. 1st Byte = "02h".
2. 2nd Byte = Address 1, MSB first (bits 23 through 16).
3. 3rd Byte = Address 2, MSB first (bits 15 through 8).
4. 4th Byte = Address 3, MSB first (bits 7 through 0).
5. 5th Byte = first write data byte.
6. In parallel mode, the fastest access clock frequency ( $F_{sck}$ ) is 10 MHz (SCK pin clock frequency).
7. Programming in parallel mode requires an "Parallel mode Entry" command (55h) before the program command. Once in the parallel mode, the flash memory will not exit parallel mode until an "Exit Parallel Mode" (45h) command is given to the flash device, or upon power down / power up sequence completion.



## 11.10 Sector Erase (SE: 20h, D8h)

The Sector Erase (SE) command sets all bits at all addresses within a specified sector to a logic 1. A WREN command is required prior to writing the PP command.

The host system must drive CS# low, and then write the SE command plus three address bytes on SI. Any address within the sector (see [Table 7.1 on page 13](#)) is a valid address for the SE command. CS# must be driven low for the entire duration of the SE sequence. The command sequence is shown in [Figure 11.16](#) and [Table 11.6](#).

The host system must drive CS# high after the device has latched the 8th bit of the SE command, otherwise the device does not execute the command. The SE operation begins as soon as CS# is driven high. The device internally controls the timing of the operation, which requires a period of  $t_{SE}$ . The Status Register may be read to check the value of the Write In Progress (WIP) bit while the SE operation is in progress. The WIP bit is 1 during the SE operation, and is 0 when the operation is completed. The device internally resets the Write Enable Latch to 0 before the operation completes (the exact timing is not specified).

The device does not execute an SE command that specifies a sector that is protected by the Block Protect bits (see [Table 7.1 on page 13](#)).

**Figure 11.16** Sector Erase (SE) Command Sequence

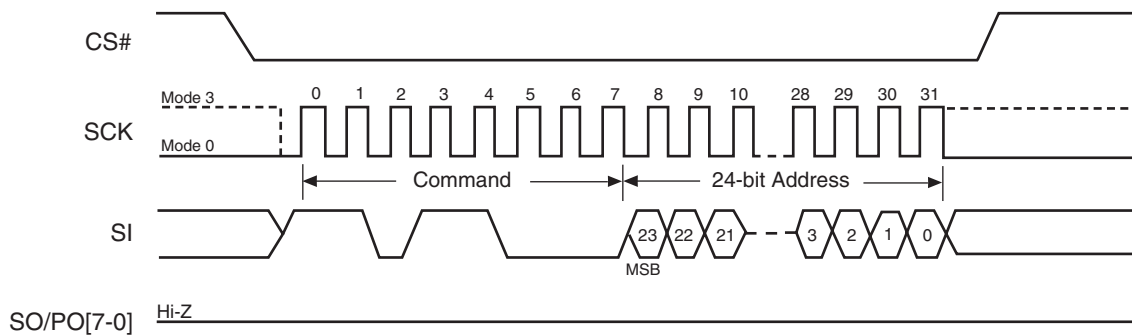

### 11.11 Bulk Erase (BE: C7h, 60h)

The Bulk Erase (BE) command sets all the bits within the entire memory array to logic 1s. A WREN command is required prior to writing the PP command.

For 64 KB sector devices, the bulk erase command may be written as either C7h or 60h. For 256 KB sector devices, only the C7h command is valid.

The host system must drive CS# low, and then write the BE command on SI. CS# must be driven low for the entire duration of the BE sequence. The command sequence is shown in [Figure 11.17](#) and [Table 11.6](#).

The host system must drive CS# high after the device has latched the 8th bit of the CE command, otherwise the device does not execute the command. The BE operation begins as soon as CS# is driven high. The device internally controls the timing of the operation, which requires a period of  $t_{BE}$ . The Status Register may be read to check the value of the Write In Progress (WIP) bit while the BE operation is in progress. The WIP bit is 1 during the BE operation, and is 0 when the operation is completed. The device internally resets the Write Enable Latch to 0 before the operation completes (the exact timing is not specified).

The device only executes a BE command if all Block Protect bits (BP2:BP0 or BP3:BP0) are 0 (see [Table 7.1 on page 13](#)). Otherwise, the device ignores the command.

**Figure 11.17** Bulk Erase (BE) Command Sequence

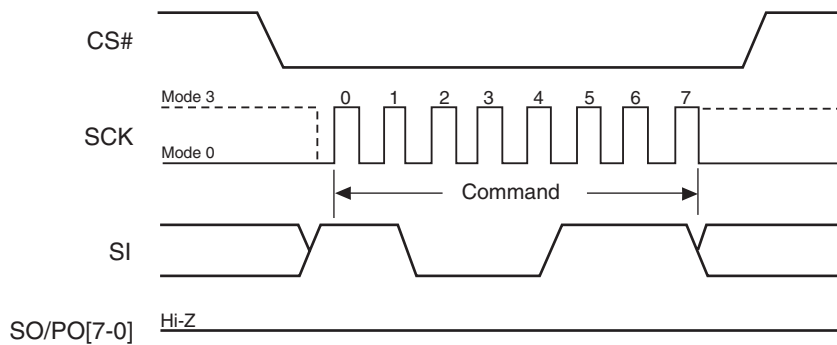

## 11.12 Deep Power Down (DP: B9h)

The Deep Power Down (DP) command provides the lowest power consumption mode of the device. It is intended for periods when the device is not in active use, and ignores all commands except for the Release from Deep Power Down (RES) command. *The DP mode therefore provides the maximum data protection against unintended write operations.* The standard standby mode, which the device goes into automatically when CS# is high (and all operations in progress are complete), should generally be used for the lowest power consumption when the quickest return to device activity is required.

The host system must drive CS# low, and then write the DP command on SI. CS# must be driven low for the entire duration of the DP sequence. The command sequence is shown in [Figure 11.18](#) and [Table 11.6](#).

The host system must drive CS# high after the device has latched the 8th bit of the DP command, otherwise the device does not execute the command. After a delay of  $t_{DP}$ , the device enters the DP mode and current reduces from  $I_{SB}$  to  $I_{DP}$  (see [Table 17.1 on page 41](#)).

Once the device has entered the DP mode, all commands are ignored except the RES command (which releases the device from the DP mode). The RES command also provides the Electronic Signature of the device to be output on SO, if desired (see sections [11.13](#) and [11.14](#)).

DP mode automatically terminates when power is removed, and the device always powers up in the standard standby mode. The device rejects any DP command issued while it is executing a program, erase, or Write Status Register operation, and continues the operation uninterrupted.

**Figure 11.18** Deep Power Down (DP) Command Sequence

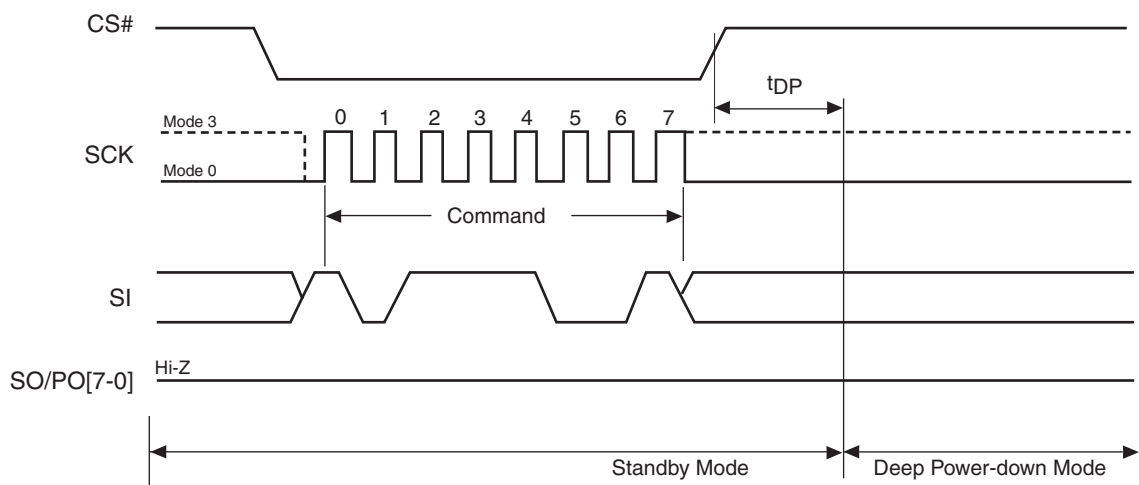

### 11.13 Release from Deep Power Down (RES: ABh)

The device requires the Release from Deep Power Down (RES) command to exit the Deep Power Down mode. When the device is in the Deep Power Down mode, all commands except RES are ignored.

The host system must drive CS# low and write the RES command to SI. CS# must be driven low for the entire duration of the sequence. The command sequence is shown in Figure 11.19 and Table 11.6.

The host system must drive CS# high  $t_{RES(max)}$  after the 8-bit RES command byte. The device transitions from DP mode to the standby mode after a delay of  $t_{RES}$  (see Table 19.1 on page 42). In the standby mode, the device can execute any read or write command.

Figure 11.19 Release from Deep Power Down (RES) Command Sequence

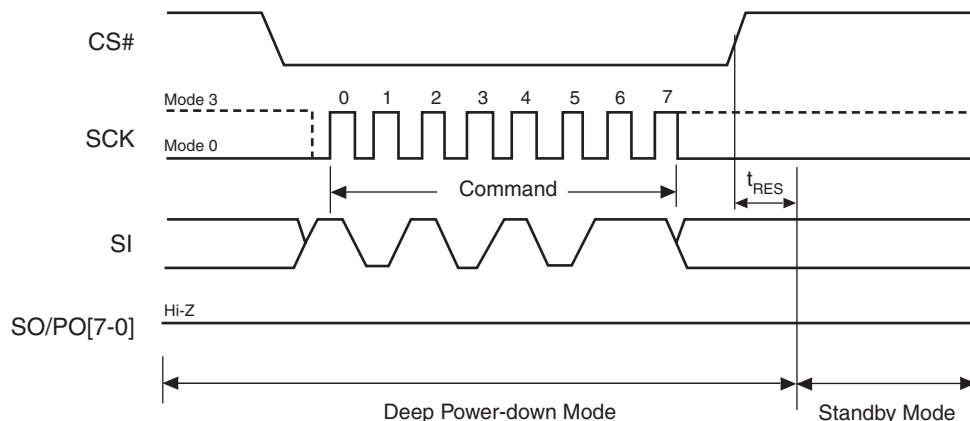

### 11.14 Release from Deep Power Down and Read Electronic Signature (RES: ABh)

#### 11.14.1 Serial Mode

This command reads the old-style Electronic Signature from the SO serial output pin. See Figure 11.20 and Table 11.6 for the command sequence and signature value. Please note that the Electronic Signature only consists of the Device ID portion of the 16-bit JEDEC ID that is read by the Read Identifier (RDID) instruction. The old style Electronic Signature is supported for backward compatibility, and should not be used for new software designs, which should instead use the JEDEC 16-bit Electronic Signature by issuing the Read Identifier (RDID) command.

The device is first selected by driving the CS# chip select input pin to the logic low state. The RES command is shifted in followed by three dummy bytes onto the SI serial input pin. After the last bit of the three dummy bytes is shifted into the device, a byte of Electronic Signature will be shifted out of the SO serial output pin. Each bit is shifted out during the falling edge of the SCK serial clock signal. The maximum clock frequency for the RES (ABh) command is at 104 MHz.

The Electronic Signature can be read repeatedly by applying multiples of eight clock cycles.

The RES instruction sequence is terminated by driving the CS# chip select input pin to the logic high state anytime during data output. After issuing any Read ID commands (90h, 9Fh, ABh), driving the CS# chip select input pin to the logic high state will automatically send the device into the standby mode. Driving the CS# chip select input pin to the logic low state again will automatically sent the device out of the standby mode and into the active mode.

**Figure 11.20** Serial Release from Deep Power Down and Read Electronic Signature (RES) Command Sequence

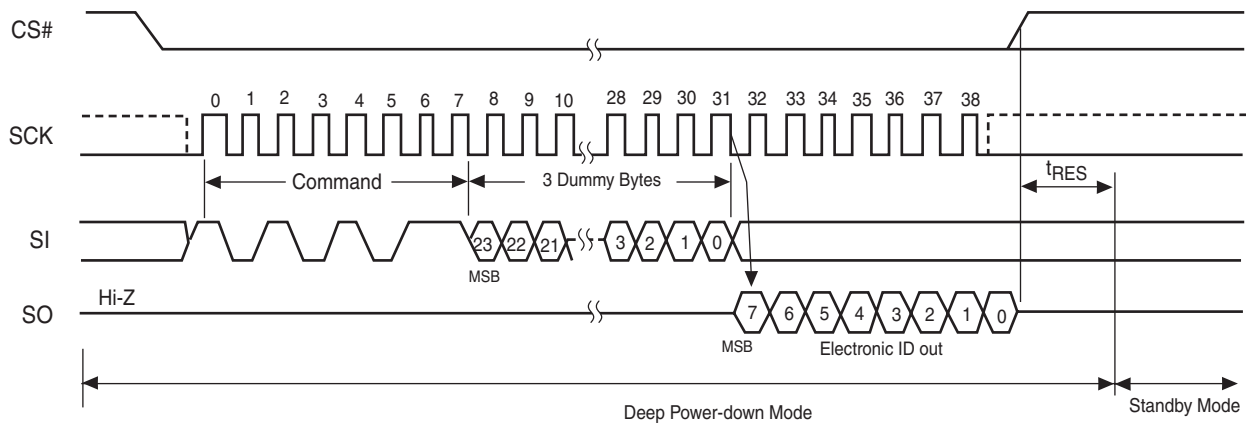

### 11.14.2 Parallel Mode

When the device is in parallel mode, the maximum SCK clock frequency is 10 MHz. The device requires a single clock cycle instead of eight clock cycles to access the next data byte. The method of memory content output will be the same compared to outside of parallel mode. The only difference is that a byte of data is output per clock cycle instead of a single bit. In this case, the Electronic Signature will be output onto the PO[7-0] serial output pins.

**Figure 11.21** Parallel Release from Deep Power Down and Read Electronic Signature (RES) Command Sequence

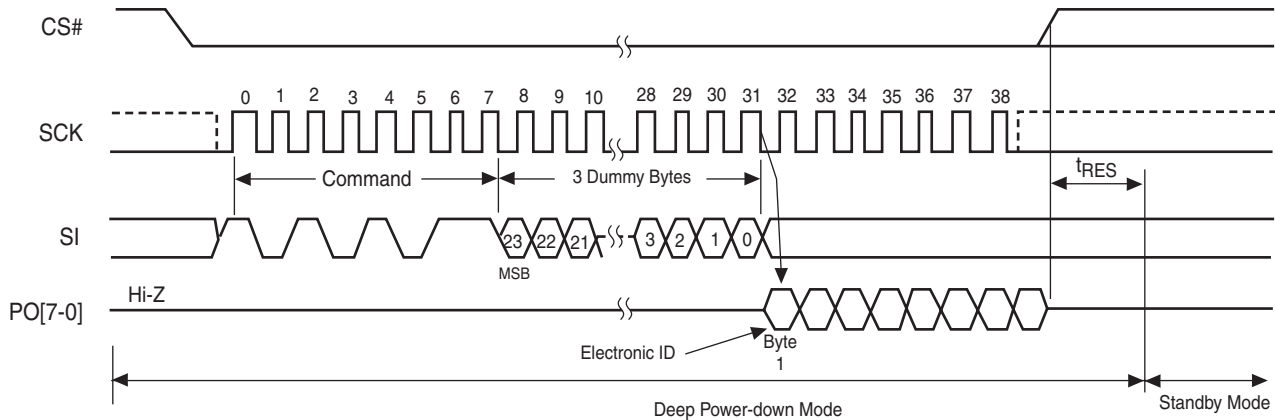

**Notes**

1. In parallel mode, the maximum access clock frequency ( $F_{sck}$ ) is 10 MHz (SCK pin clock frequency).
2. To release the device from Deep Power Down and read Electronic ID in parallel mode, a Parallel Mode Enter command (55h) must be issued before the RES command. The device will not exit parallel mode until a Parallel Mode Exit command (45h) is written, or upon power-down or power-up sequence.
3. Byte 1 will output the Electronic Signature.

## 11.15 Command Definitions

Table 11.6 Command Definitions

Operation	Command	Description	One-Byte Command Code	Address Bytes	Dummy Byte	Data Bytes
Read	READ	Read Data Bytes	03h (0000 0011)	3	0	1 to ∞
	FAST_READ	Read Data Bytes at Higher Speed	0Bh (0000 1011)	3	1	1 to ∞
	RDID	Read Identification	9Fh (1001 1111)	0	0	1 to 3
	READ_ID	Read Manufacturer ID and Device ID	90h (1001 0000)	3	0	1 to ∞
Write Control	WREN	Write Enable	06h (0000 0110)	0	0	0
	WRDI	Write Disable	04h (0000 0100)	0	0	0
Erase	SE	64 KB Sector Erase (See Note)	20h (0010 0000) or D8h (1101 1000)	3	0	0
		256 KB Sector Erase	D8h (1101 1000)	3	0	0
	BE	Bulk (Chip) Erase, Uniform 64 KB Sector Product (See Note)	C7h (1100 0111) or 60h (0110 0000)	0	0	0
		Bulk (Chip) Erase, Uniform 256 KB Sector Product	C7h (1100 0111)	0	0	0
Program	PP	Page Program	02h (0000 0010)	3	0	1 to 256
Status Register	RDSR	Read from Status Register	05h (0000 0101)	0	0	1 to ∞
	WRSR	Write to Status Register	01h (0000 0001)	0	0	1
Parallel Mode	Entry	Enter x8 Parallel Mode	55h (0101 0101)	0	0	0
	Exit	Exit x8 Parallel Mode	45h (0100 0101)	0	0	0
Power Saving	DP	Deep Power Down	B9h (1011 1001)	0	0	0
	RES	Release from Deep Power Down	ABh (1010 1011)	0	0	0
		Release from Deep Power Down and Read Electronic Signature	ABh (1010 1011)	0	3	1 to ∞

**Note**

For 64 KB sector devices, either command is valid and performs the same function.

## 12. Program Acceleration via WP#/ACC pin

The program acceleration function requires applying  $V_{HH}$  to the WP#/ACC input, and then waiting a period of  $t_{WC}$ . Minimum  $t_{VHH}$  rise and fall times is required for WP#/ACC to change to  $V_{HH}$  from  $V_{IL}$  or  $V_{IH}$ . Removing  $V_{HH}$  from the WP#/ACC pin returns the device to normal operation after a period of  $t_{WC}$ .

Figure 12.1 ACC Program Acceleration Timing Requirements

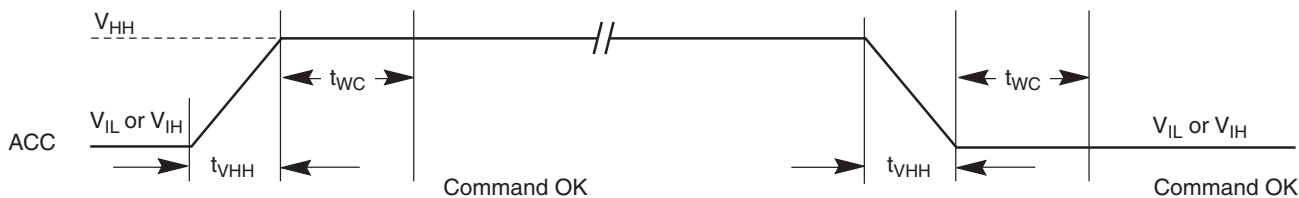

**Note**

Only Read Status Register (RDSR) and Page Program (PP) operations are allow when ACC is at ( $V_{HH}$ ).

Table 12.1 ACC Program Acceleration Specifications

Parameter	Description	Min.	Max.	Unit
$V_{HH}$	ACC Pin Voltage High	8.5	9.5	V
$t_{VHH}$	ACC Voltage Rise and Fall Time	250		ns
$t_{WC}$	ACC at $V_{HH}$ and $V_{IL}$ or $V_{IH}$ to First command	5		ns

### 13. Power-up and Power-down

During power-up and power-down, certain conditions must be observed. CS# must follow the voltage applied on  $V_{CC}$ , and must not be driven low to select the device until  $V_{CC}$  reaches the allowable values as follows (see [Figure 13.1](#) and [Table 13.1](#)):

- At power-up,  $V_{CC}$  (min.) plus a period of  $t_{PU}$
- At power-down,  $V_{SS}$

A pull-up resistor on Chip Select (CS#) typically meets proper power-up and power-down requirements.

No Write Status Register, program, or erase command should be sent to the device until  $V_{CC}$  rises to the  $V_{CC}$  minimum, plus a delay of  $t_{PU}$ . At power-up, the device is in standby mode (not Deep Power Down mode) and the WEL bit is reset (0).

Each device in the host system should have the  $V_{CC}$  rail decoupled by a suitable capacitor close to the package pins (this capacitor is generally of the order of 0.1  $\mu\text{F}$ ), as a precaution to stabilizing the  $V_{CC}$  feed.

When  $V_{CC}$  drops from the operating voltage to below the minimum  $V_{CC}$  threshold at power-down, all operations are disabled and the device does not respond to any commands. Note that data corruption may result if a power-down occurs while a Write Register, program, or erase operation is in progress.

**Figure 13.1** Power-Up Timing Diagram

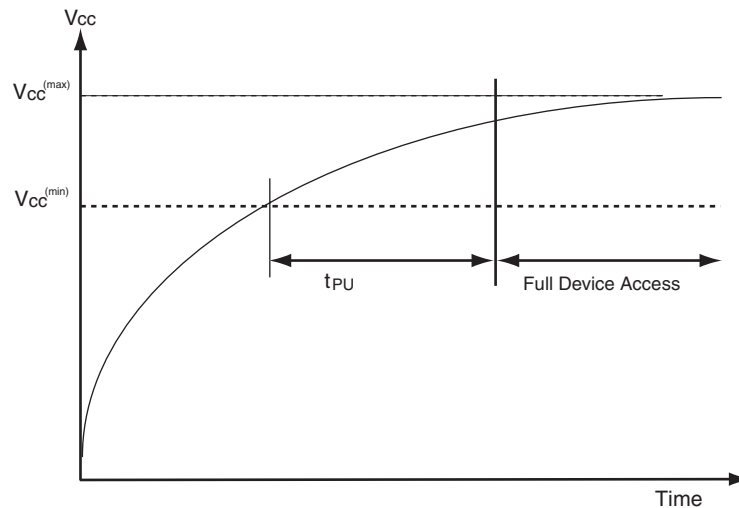

**Table 13.1** Power-Up Timing Characteristics

Symbol	Parameter	Min	Max	Unit
$V_{CC(\text{min})}$	$V_{CC}$ (minimum)	2.7		V
$t_{PU}$	$V_{CC}$ (min) to device operation	15		ms

### 14. Initial Delivery State

The device is delivered with all bits set to 1 (each byte contains FFh) upon initial factory shipment. The Status Register contains 00h (all Status Register bits are 0).

## 15. Absolute Maximum Ratings

Do not stress the device beyond the ratings listed in this section, or serious, permanent damage to the device may result. These are stress ratings only and device operation at these or any other conditions beyond those indicated in this section and in the *Operating Ranges* section of this document is not implied. Device operation for extended periods at the limits listed in this section may affect device reliability.

**Table 15.1** Absolute Maximum Ratings

Description	Rating
Ambient Storage Temperature	-65°C to +150°C
Voltage with Respect to Ground: All Inputs and I/Os	-0.5 V to $V_{CC}+0.5$ V

**Notes**

1. Minimum DC voltage on input or I/O pins is -0.5 V. During voltage transitions, input at I/O pins may overshoot  $V_{SS}$  to -2.0 V for periods of up to 20 ns. See *Figure 15.2*. Maximum DC voltage on output and I/O pins is 3.6 V. During voltage transitions output pins may overshoot to  $V_{CC} + 2.0$  V for periods up to 20 ns. See *Figure 15.2*.
2. No more than one output may be shorted to ground at a time. Duration of the short circuit should not be greater than one second.
3. Stresses above those listed under *Absolute Maximum Ratings* may cause permanent damage to the device. This is a stress rating only; functional operation of the device at these or any other conditions above those indicated in the operational sections of this data sheet is not implied. Exposure of the device to absolute maximum rating conditions for extended periods may affect device reliability.

**Figure 15.1** Maximum Negative Overshoot Waveform

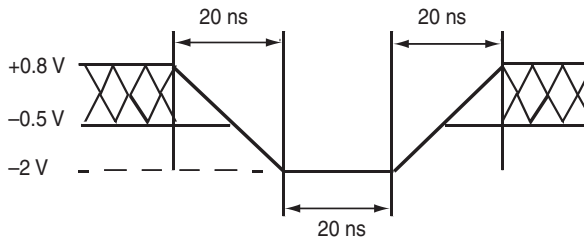

**Figure 15.2** Maximum Positive Overshoot Waveform

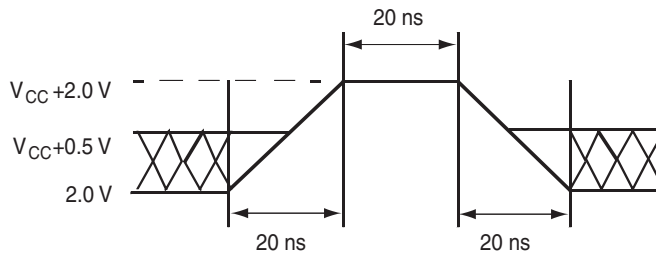

## 16. Operating Ranges

**Table 16.1** Operating Ranges

Description	Rating	
Ambient Operating Temperature ( $T_A$ )	Industrial	-40°C to +85°C
Positive Power Supply	Voltage Range	2.7 V to 3.6 V

**Note**

Operating ranges define those limits between which functionality of the device is guaranteed.



## 17. DC Characteristics

This section summarizes the DC Characteristics of the device. Designers should check that the operating conditions in their circuit match the measurement conditions specified in the Test Specifications in [Table 18.1 on page 41](#), when relying on the quoted parameters.

**Table 17.1** DC Characteristics (CMOS Compatible)

Parameter	Description	Test Conditions (See Note)	Min	Typ.	Max	Unit
$V_{CC}$	Supply Voltage		2.7		3.6	V
$I_{CC1}$	Active Read Current	$SCK = 0.1 V_{CC} / 0.9V_{CC}$			22	mA
		$SCK = 0.1 V_{CC} / 0.9V_{CC}$	104 MHz (Serial)			
			40 MHz (Serial: Fast Read Mode)			10
		3 MHz (Parallel Mode)			10	mA
$I_{CC2}$	Active Page Program Current	$CS\# = V_{CC}$			26	mA
$I_{CC3}$	Active WRSR Current	$CS\# = V_{CC}$			26	mA
$I_{CC4}$	Active Sector Erase Current	$CS\# = V_{CC}$			26	mA
$I_{CC5}$	Active Bulk Erase Current	$CS\# = V_{CC}$			26	mA
$I_{SB}$	Standby Current	$V_{IN} = GND$ or $V_{CC}$ , $CS\# = V_{CC}$			200	$\mu A$
$I_{DP}$	Deep Power Down Current	$V_{IN} = GND$ or $V_{CC}$ , $CS\# = V_{CC}$		3	20	$\mu A$
$I_{LI}$	Input Leakage Current	$V_{IN} = GND$ or $V_{CC}$ , $V_{CC} = V_{CCmax}$			2	$\mu A$
$I_{LO}$	Output Leakage Current	$V_{IN} = GND$ to $V_{CC}$ , $V_{CC} = V_{CCmax}$			2	$\mu A$
$V_{IL}$	Input Low Voltage		-0.3		$0.3 V_{CC}$	V
$V_{IH}$	Input High Voltage		$0.7 V_{CC}$		$V_{CC} + 0.5$	V
$V_{OL}$	Output Low Voltage	$I_{OL} = 1.6$ mA, $V_{CC} = V_{CCmin}$			0.4	V
$V_{OH}$	Output High Voltage	$I_{OH} = -0.1$ mA	$V_{CC} - 0.6$			V

**Note**

Typical values are at  $T_A = 25^\circ C$  and 3.0 V.

## 18. Test Conditions

**Figure 18.1** AC Measurements I/O Waveform

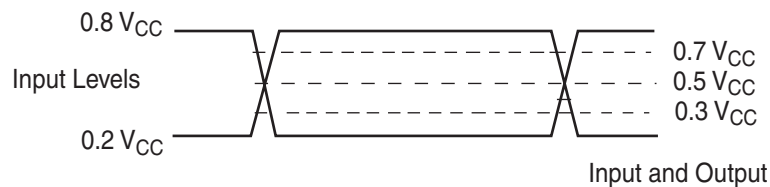

**Table 18.1** Test Specifications

Symbol	Parameter	Min	Max	Unit
$C_L$	Load Capacitance		30	pF
	Input Rise and Fall Times		5	ns
	Input Pulse Voltage	$0.2 V_{CC}$ to $0.8 V_{CC}$		V
	Input Timing Reference Voltage	$0.3 V_{CC}$ to $0.7 V_{CC}$		V
	Output Timing Reference Voltage	$0.5 V_{CC}$		V

## 19. AC Characteristics

Table 19.1 AC Characteristics

Symbol	Parameter	Min	Typ (Notes)	Max (Notes)	Unit
$F_{SCK}$	SCK Clock Frequency READ command	D.C.		40 (Serial) 6 (Parallel)	MHz
$F_{SCK}$	SCK Clock Frequency for: FAST_READ, RDID, READ_ID, PP, SE, BE, DP, RES, WREN, WRDI, RDSR, WRSR (Note 4)	D.C.		104 (Serial) 10 (Parallel)	MHz
$t_{CRT}$	Clock Rise Time (Slew Rate)	0.1 (Serial) 0.25 (Parallel)			V/ns
$t_{CFT}$	Clock Fall Time (Slew Rate)	0.1 (Serial) 0.25 (Parallel)			V/ns
$t_{WH}$	SCK High Time	4.5 (Serial) 50 (Parallel)			ns
$t_{WL}$	SCK Low Time	4.5 (Serial) 50 (Parallel)			ns
$t_{CS}$	CS# High Time	100 (Serial) 20 (Parallel)			ns
$t_{CSS}$	CS# Setup Time (Note 3)	3			ns
$t_{CSH}$	CS# HOLD Time (Note 3)	3			ns
$t_{HD}$	HOLD# Setup Time (relative to SCK) (Note 3)	3			ns
$t_{CD}$	HOLD# Non-Active Hold Time (relative to SCK) (Note 3)	3			ns
$t_{HC}$	HOLD# Non-Active Setup Time (relative to SCK)	3			ns
$t_{CH}$	HOLD# Hold Time (relative to SCK)	3			ns
$t_V$	Output Valid	0		8 (Serial) 20 (Parallel)	ns
$t_{HO}$	Output Hold Time	0			ns
$t_{HD-DAT}$	Data in Hold Time	2 (Serial) 10 (Parallel)			ns
$t_{SU-DAT}$	Data in Setup Time	3 (Serial) 10 (Parallel)			ns
$t_R$	Input Rise Time			5	ns
$t_F$	Input Fall Time			5	ns
$t_{LZ}$	HOLD# to Output Low Z (Note 3)			8 (Serial) 20 (Parallel)	ns
$t_{HZ}$	HOLD# to Output High Z (Note 3)			8 (Serial) 20 (Parallel)	ns
$t_{DIS}$	Output Disable Time (Note 3)			8 (Serial) 20 (Parallel)	ns
$t_{WPS}$	Write Protect Setup Time (Notes 3, 5)	20			ns
$t_{WPH}$	Write Protect Hold Time (Notes 3, 5)	100			ns
$t_W$	Write Status Register Time			100	ms
$t_{DP}$	CS# High to Deep Power Down Mode			3	$\mu$ s
$t_{RES}$	Release DP Mode			30	$\mu$ s
$t_{PP}$	Page Programming Time		1.5 (Note 1)	3 (Note 2)	ms
$t_{EP}$	Page Programming Time (WP#/ACC = 9 V)		1.2 (Note 1)	2.4 (Note 2)	sec
$t_{SE}$	Sector Erase Time (64 KB)		0.5 (Note 1)	3 (Note 2)	sec
$t_{SE}$	Sector Erase Time (256 KB)		2 (Note 1)	12 (Note 2)	sec
$t_{BE}$	Bulk Erase Time		128 (Note 1)	768 (Note 2)	sec

### Notes

1. Typical program and erase times assume the following conditions: 25°C,  $V_{CC} = 3.0$  V; 10,000 cycles; checkerboard data pattern
2. Under worst-case conditions of 90°C;  $V_{CC} = 2.7$  V; 100,000 cycles
3. Not 100% tested.
4. FAST\_READ is not valid in parallel mode.
5. Only applicable as a constraint for WRSR command when SRWD is set to a '1'.

Figure 19.1 SPI Mode 0 (0,0) Input Timing

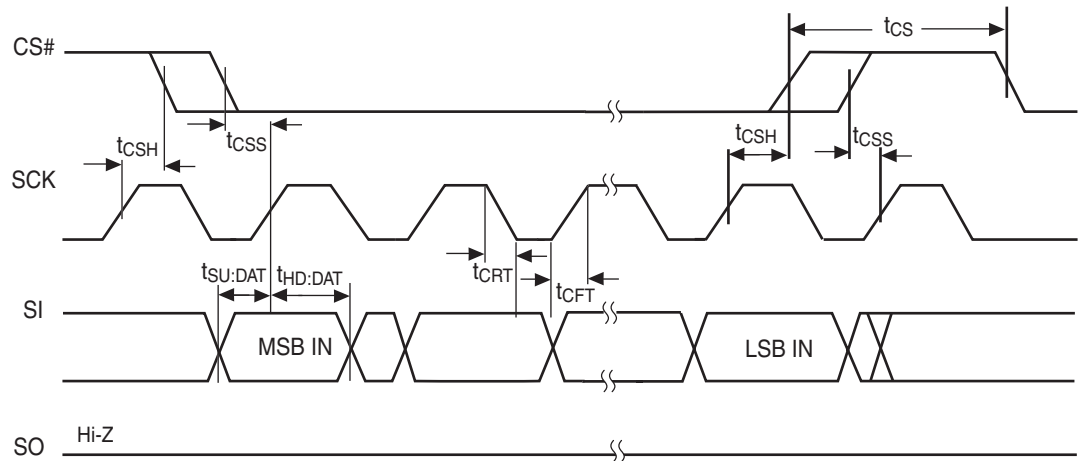

Figure 19.2 SPI Mode 0 (0,0) Output Timing

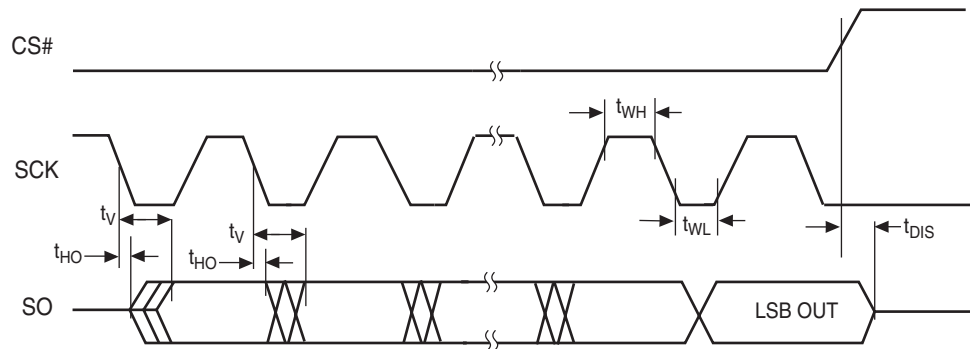

Figure 19.3 HOLD# Timing

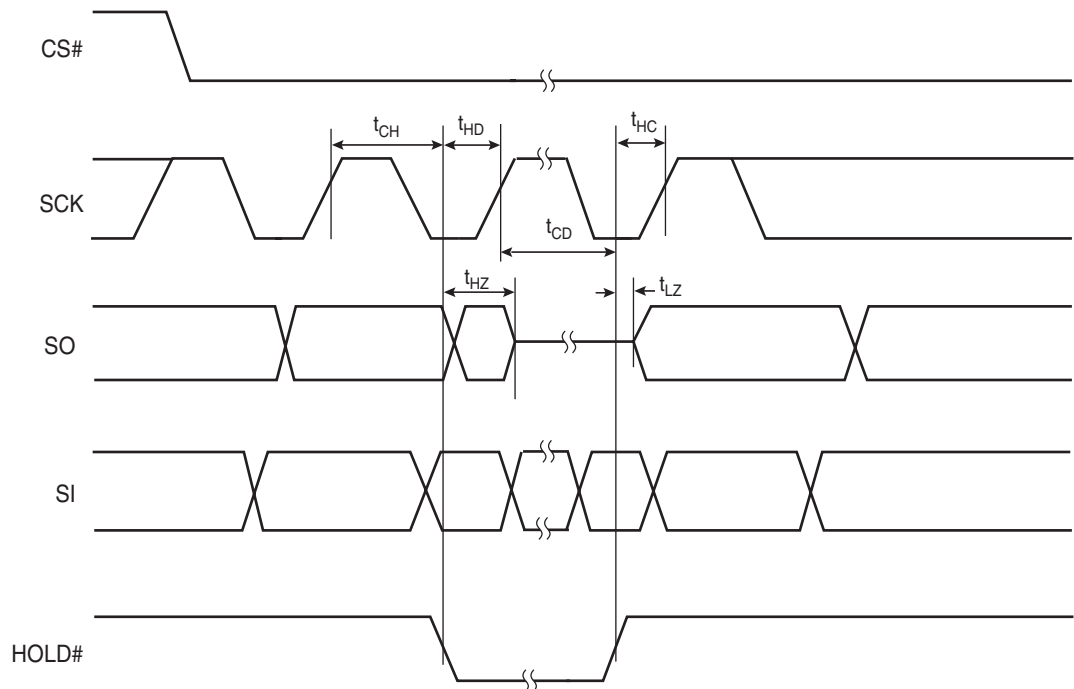
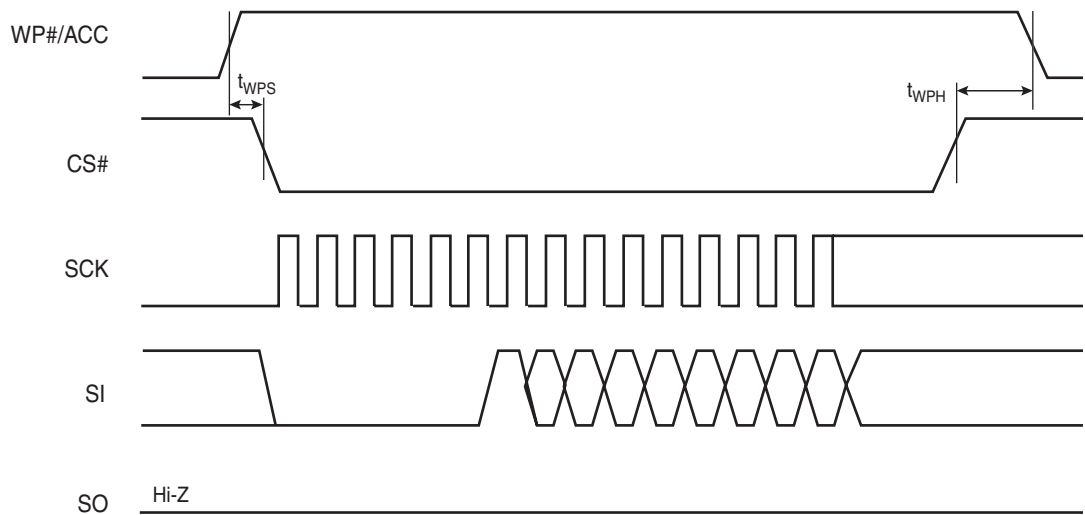
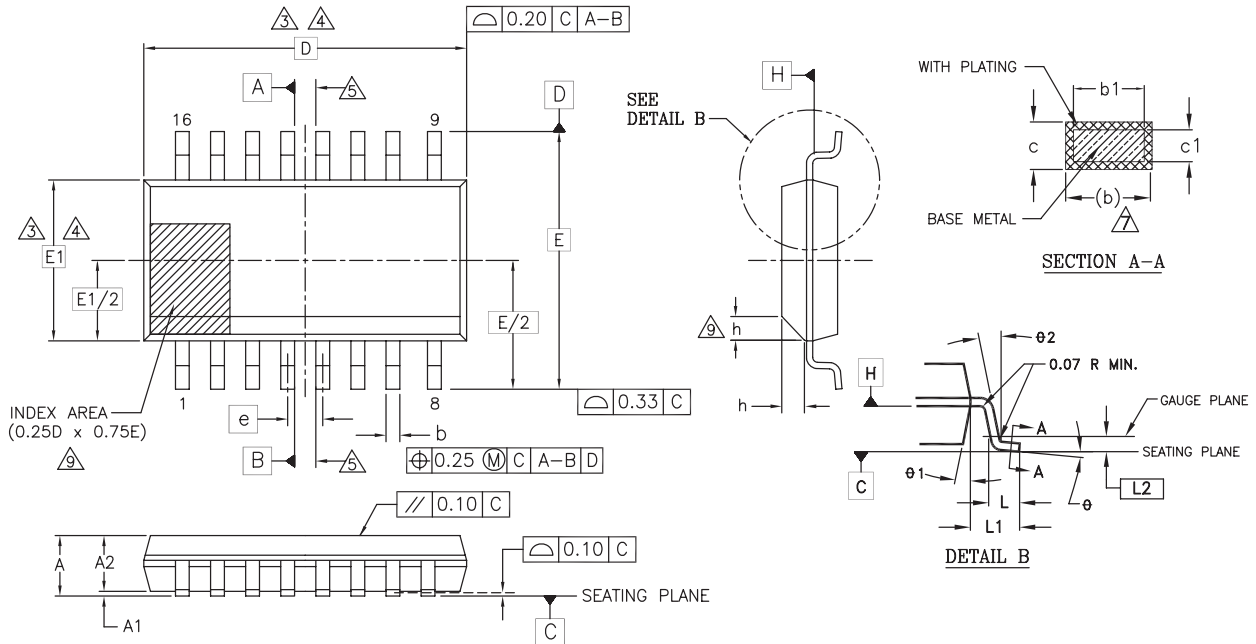

Figure 19.4 Write Protect Setup and Hold Timing during WRSR when SRWD=1



## 20. Physical Dimensions

### 20.1 SO3 016 wide—16-pin Plastic Small Outline Package (300-mil Body Width)



PACKAGE	SO3 016 (inches)		SO3 016 (mm)	
	MS-013(D)AA		MS-013(D)AA	
SYMBOL	MIN	MAX	MIN	MAX
A	0.093	0.104	2.35	2.65
A1	0.004	0.012	0.10	0.30
A2	0.081	0.104	2.05	2.55
b	0.012	0.020	0.31	0.51
b1	0.011	0.019	0.27	0.48
c	0.008	0.013	0.20	0.33
c1	0.008	0.012	0.20	0.30
D	0.406 BSC		10.30 BSC	
E	0.406 BSC		10.30 BSC	
E1	0.295 BSC		7.50 BSC	
e	.050 BSC		1.27 BSC	
L	0.016	0.050	0.40	1.27
L1	.055 REF		1.40 REF	
L2	.010 BSC		0.25 BSC	
N	16		16	
h	0.10	0.30	0.25	0.75
θ	0°	8°	0°	8°
θ1	5°	15°	5°	15°
θ2	0°		0°	

NOTES:

- ALL DIMENSIONS ARE IN BOTH INCHES AND MILLIMETERS.
- DIMENSIONING AND TOLERANCING PER ASME Y14.5M - 1994.
3. DIMENSION D DOES NOT INCLUDE MOLD FLASH, PROTRUSIONS OR GATE BURRS. MOLD FLASH, PROTRUSIONS OR GATE BURRS SHALL NOT EXCEED 0.15 mm PER END. DIMENSION E1 DOES NOT INCLUDE INTERLEAD FLASH OR PROTRUSION INTERLEAD FLASH OR PROTRUSION SHALL NOT EXCEED 0.25 mm PER SIDE. D AND E1 DIMENSIONS ARE DETERMINED AT DATUM H.
4. THE PACKAGE TOP MAY BE SMALLER THAN THE PACKAGE BOTTOM. DIMENSIONS D AND E1 ARE DETERMINED AT THE OUTMOST EXTREMES OF THE PLASTIC BODY EXCLUSIVE OF MOLD FLASH, TIE BAR BURRS, GATE BURRS AND INTERLEAD FLASH. BUT INCLUDING ANY MISMATCH BETWEEN THE TOP AND BOTTOM OF THE PLASTIC BODY.
5. DATUMS A AND B TO BE DETERMINED AT DATUM H.
6. "N" IS THE MAXIMUM NUMBER OF TERMINAL POSITIONS FOR THE SPECIFIED PACKAGE LENGTH.
7. THE DIMENSIONS APPLY TO THE FLAT SECTION OF THE LEAD BETWEEN 0.10 TO 0.25 mm FROM THE LEAD TIP.
8. DIMENSION "b" DOES NOT INCLUDE DAMBAR PROTRUSION. ALLOWABLE DAMBAR PROTRUSION SHALL BE 0.10 mm TOTAL IN EXCESS OF THE "b" DIMENSION AT MAXIMUM MATERIAL CONDITION. THE DAMBAR CANNOT BE LOCATED ON THE LOWER RADIUS OF THE LEAD FOOT.
9. THIS CHAMFER FEATURE IS OPTIONAL. IF IT IS NOT PRESENT, THEN A PIN 1 IDENTIFIER MUST BE LOCATED WITHIN THE INDEX AREA INDICATED.
10. LEAD COPLANARITY SHALL BE WITHIN 0.10 mm AS MEASURED FROM THE SEATING PLANE.

36011 16-038.03 18.31.6

## 20.2 WSON 8-contact (6 x 8 mm) No-Lead Package

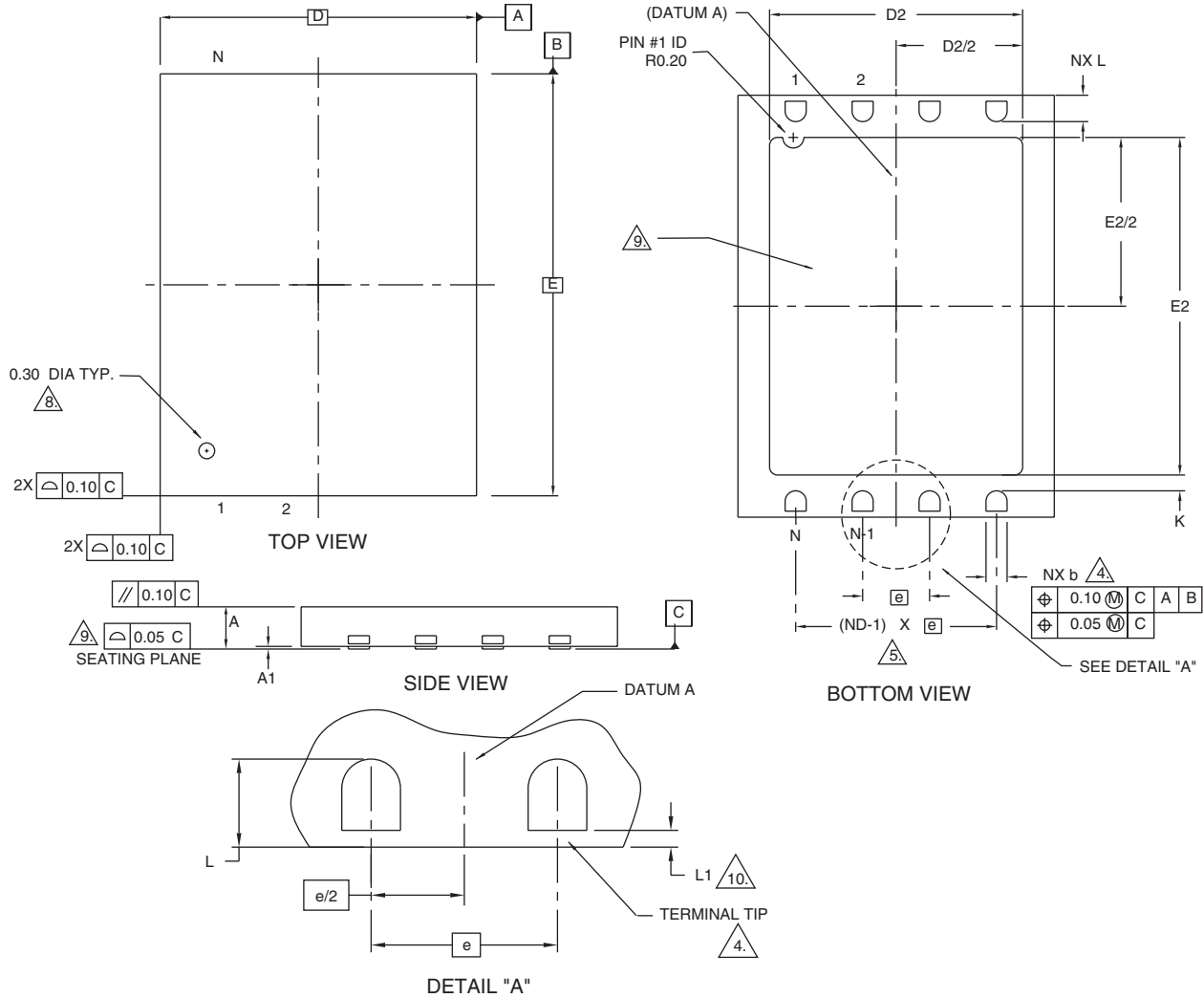

QUAD FLAT NO LEAD PACKAGES (WSNB) - PLASTIC				
SYMBOL	DIMENSIONS			NOTE
	MIN	NOM	MAX	
$e$	1.27 BSC			
N	8			3
ND	4			5
L	0.45	0.50	0.55	
b	0.35	0.40	0.45	4
D2	4.70	4.80	4.90	
E2	6.30	6.40	6.50	
D	6.00 BSC			
E	8.00 BSC			
A	0.70	0.75	0.80	
A1	0.00	0.02	0.05	
L1	0.15 MAX.			10
$\theta$	0	---	12	2
K	0.20 MIN.			

**NOTES:**

1. DIMENSIONING AND TOLERANCING CONFORMS TO ASME Y14.5M-1994.
2. ALL DIMENSIONS ARE IN MILLIMETERS, SYM  $\theta$  IS IN DEGREES.
3. N IS THE TOTAL NUMBER OF TERMINALS.
4. DIMENSION b APPLIES TO METALLIZED TERMINAL AND IS MEASURED BETWEEN 0.15 AND 0.30 mm FROM TERMINAL TIP. IF THE TERMINAL HAS THE OPTIONAL RADIUS ON THE OTHER END OF THE TERMINAL, THE DIMENSION b SHOULD NOT BE MEASURED IN THAT RADIUS AREA.
5. ND REFERS TO THE NUMBER OF TERMINALS ON D SIDE.
6. MAXIMUM PACKAGE WARPAGE IS 0.05 mm.
7. MAXIMUM ALLOWABLE BURRS IS 0.076 mm IN ALL DIRECTIONS.
8. PIN #1 ID ON TOP WILL BE LASER MARKED.
9. BILATERAL COPLANARITY ZONE APPLIES TO THE EXPOSED HEAT SINK SLUG AS WELL AS THE TERMINALS.
10. A MAXIMUM 0.15 mm PULL BACK (L1) MAY BE PRESENT.

## 21. Revision History

Section	Description
<b>Revision 01 (January 12, 2007)</b>	
	Initial release.
<b>Revision 02 (March 13, 2007)</b>	
Distinctive Characteristics	Changed standby mode current.
S25FL128P Sector Address Table (Uniform 64 KB sector)	Corrected addresses for sectors 0 and 32.
Parallel Mode (for 16-pin SO package only)	Added last sentence in section.
Read Status Register (RDSR: 05h)	Separated status register bit descriptions into an additional subsection.
Page Program (PP: 02h)	Modified Parallel Page Program (PP) Instruction Sequence figure to match format of other parallel mode figures.
Command Definitions	Changed code for Bulk Erase (BE) 256 KB product in table.
Read Manufacturer and Device ID (READ_ID: 90h)	Corrected SI and CLK in Parallel Read_ID Instruction Sequence figure.
Absolute Maximum Ratings	Added overshoot and undershoot information.
DC Characteristics	Changed maximum specifications for $I_{CC1}$ (parallel mode), $I_{SB}$ , and $I_{DP}$
<b>Revision 03 (April 24, 2007)</b>	
Ordering Information	Changed Valid Combinations table.
<b>Revision 04 (July 2, 2007)</b>	
Device Operations	Added a sentence to Byte or Page programming
Parallel Mode (for 16-pin SO package only)	Added a sentence.

**Colophon**

The products described in this document are designed, developed and manufactured as contemplated for general use, including without limitation, ordinary industrial use, general office use, personal use, and household use, but are not designed, developed and manufactured as contemplated (1) for any use that includes fatal risks or dangers that, unless extremely high safety is secured, could have a serious effect to the public, and could lead directly to death, personal injury, severe physical damage or other loss (i.e., nuclear reaction control in nuclear facility, aircraft flight control, air traffic control, mass transport control, medical life support system, missile launch control in weapon system), or (2) for any use where chance of failure is intolerable (i.e., submersible repeater and artificial satellite). Please note that Spansion will not be liable to you and/or any third party for any claims or damages arising in connection with above-mentioned uses of the products. Any semiconductor devices have an inherent chance of failure. You must protect against injury, damage or loss from such failures by incorporating safety design measures into your facility and equipment such as redundancy, fire protection, and prevention of over-current levels and other abnormal operating conditions. If any products described in this document represent goods or technologies subject to certain restrictions on export under the Foreign Exchange and Foreign Trade Law of Japan, the US Export Administration Regulations or the applicable laws of any other country, the prior authorization by the respective government entity will be required for export of those products.

**Trademarks and Notice**

The contents of this document are subject to change without notice. This document may contain information on a Spansion product under development by Spansion. Spansion reserves the right to change or discontinue work on any product without notice. The information in this document is provided as is without warranty or guarantee of any kind as to its accuracy, completeness, operability, fitness for particular purpose, merchantability, non-infringement of third-party rights, or any other warranty, express, implied, or statutory. Spansion assumes no liability for any damages of any kind arising out of the use of the information in this document.

Copyright © 2007 Spansion Inc. All rights reserved. Spansion®, the Spansion Logo, MirrorBit®, MirrorBit® Eclipse™, ORNAND™, HD-SIM™ and combinations thereof, are trademarks of Spansion LLC in the US and other countries. Other names used are for informational purposes only and may be trademarks of their respective owners.