

System-in-package integrating microstepping controller and 10 A power MOSFETs

Datasheet - production data

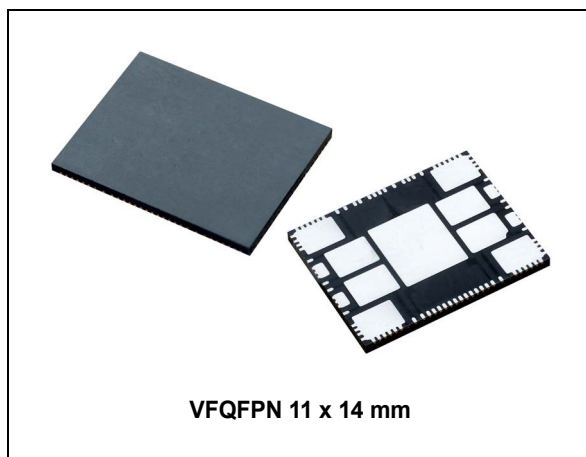

Features

- Power system-in-package integrating a programmable microstepping controller and 8 N-channel power MOSFETs.
- Operating voltage: 7.5 V - 85 V
- Dual full bridge with $R_{DS(on)} = 16 \text{ m}\Omega$
- 10 A_{r.m.s.} maximum output current
- Adjustable output slew rate
- Programmable speed profile
- Up to 1/128 microstepping
- Sensorless stall detection
- Integrated voltage regulators
- SPI interface
- Low quiescent standby currents
- Programmable non-dissipative overcurrent protection
- Overtemperature protection

Applications

- High power bipolar stepper motor
 - Stage lighting
 - Surveillance systems
 - Textile and sewing machines
 - Pick and place machines

Description

The powerSTEP01 is a system-in-package integrating 8 N-channel 16 mΩ MOSFETs for stepper applications up to 85 V with a SPI programmable controller, providing fully digital control of the motion through a speed profile generation and positioning calculations.

It integrates a dual low $R_{DS(on)}$ full bridge with embedded non-dissipative overcurrent protection. The device can operate with both voltage mode driving and advanced current control fitting different application needs. The digital control core can generate user defined motion profiles with acceleration, deceleration, speed or a target position easily programmed through a dedicated register set. All application commands and data registers, including those used to set analog values (i.e. current protection trip point, deadtime, PWM frequency, etc.) are sent through a standard 5-Mbit/s SPI. A very rich set of protections (thermal, low bus voltage, overcurrent and motor stall) make the powerSTEP01 “bullet proof”, as required by the most demanding motor control applications.

Table 1. Device summary

Order code	Package	Packing
POWERSTEP01	VFQFPN 11 x 14 x 1.0 mm	Tray
POWERSTEP01TR	VFQFPN 11 x 14 x 1.0 mm	Tape and reel

Contents

- 1 Block diagram 9**
- 2 Electrical data 10**
 - 2.1 Absolute maximum ratings 10
 - 2.2 Recommended operating conditions 11
- 3 Electrical characteristics 12**
- 4 Pin connection 17**
- 5 Pin list 18**
- 6 Typical applications 20**
- 7 Functional description 22**
 - 7.1 Device power-up 22
 - 7.2 Logic I/O 22
 - 7.3 Charge pump 22
 - 7.4 Microstepping 23
 - Automatic Full-step and Boost modes 24
 - 7.5 Absolute position counter 25
 - 7.6 Programmable speed profiles 25
 - 7.7 Motor control commands 26
 - 7.7.1 Constant speed commands 26
 - 7.7.2 Positioning commands 26
 - 7.7.3 Motion commands 27
 - 7.7.4 Stop commands 27
 - 7.7.5 Step-clock mode 28
 - 7.7.6 GoUntil and ReleaseSW commands 28
 - 7.8 Internal oscillator and oscillator driver 29
 - 7.8.1 Internal oscillator 29
 - 7.8.2 External clock source 29
 - 7.9 Overcurrent detection 30
 - 7.10 Undervoltage lockout (UVLO) 31

7.11	VS undervoltage lockout (UVLO_ADC)	32
7.12	Thermal warning and thermal shutdown	32
7.13	Reset and standby	33
7.14	External switch (SW pin)	33
7.15	Integrated power MOSFETs	34
7.16	Programmable slew rate	34
7.17	Deadtime and blanking time	35
7.18	Integrated analog-to-digital converter	35
7.19	Supply management and internal voltage regulators	36
7.20	BUSY/SYNC pin	37
7.21	FLAG pin	37
8	Phase current control: voltage mode	38
8.1	PWM sinewave generators	39
8.2	Sensorless stall detection	39
8.3	Low speed optimization	39
8.4	BEMF compensation	40
8.5	Motor supply voltage compensation	41
8.6	Winding resistance thermal drift compensation	42
9	Phase current control: current mode	43
9.1	Predictive current control	43
9.2	Auto-adjusted decay mode	44
9.3	Auto-adjusted fast decay during the falling steps	46
9.4	Torque regulation (setting the output current)	47
10	Serial interface	49
11	Programming manual	51
11.1	Register and flag description	51
11.1.1	ABS_POS	53
11.1.2	EL_POS	53
11.1.3	MARK	53
11.1.4	SPEED	53
11.1.5	ACC	54

11.1.6	DEC	54
11.1.7	MAX_SPEED	54
11.1.8	MIN_SPEED	55
11.1.9	FS_SPD	55
11.1.10	KVAL_HOLD, KVAL_RUN, KVAL_ACC and KVAL_DEC	56
11.1.11	INT_SPEED	56
11.1.12	ST_SLP	56
11.1.13	FN_SLP_ACC	57
11.1.14	FN_SLP_DEC	57
11.1.15	K_THERM	57
11.1.16	TVAL_HOLD, TVAL_RUN, TVAL_ACC and TVAL_DEC	58
11.1.17	T_FAST	58
11.1.18	TON_MIN	59
11.1.19	TOFF_MIN	59
11.1.20	ADC_OUT	60
11.1.21	OCD_TH	61
11.1.22	STALL_TH	61
11.1.23	STEP_MODE	61
11.1.24	ALARM_EN	63
11.1.25	GATECFG1	63
11.1.26	GATECFG2	64
11.1.27	CONFIG	66
11.1.28	STATUS	71
11.2	Application commands	73
11.2.1	Command management	74
11.2.2	Nop	75
11.2.3	SetParam (PARAM, VALUE)	75
11.2.4	GetParam (PARAM)	75
11.2.5	Run (DIR, SPD)	76
11.2.6	StepClock (DIR)	76
11.2.7	Move (DIR, N_STEP)	77
11.2.8	GoTo (ABS_POS)	77
11.2.9	GoTo_DIR (DIR, ABS_POS)	78
11.2.10	GoUntil (ACT, DIR, SPD)	78
11.2.11	ReleaseSW (ACT, DIR)	79
11.2.12	GoHome	79
11.2.13	GoMark	80

	11.2.14	ResetPos	80
	11.2.15	ResetDevice	80
	11.2.16	SoftStop	81
	11.2.17	HardStop	81
	11.2.18	SoftHiZ	81
	11.2.19	HardHiZ	82
	11.2.20	GetStatus	82
12		Package information	83
		VFQFPN package information	83
13		Revision history	91

List of tables

Table 1.	Device summary	1
Table 2.	Absolute maximum ratings	10
Table 3.	Recommended operating conditions	11
Table 4.	Electrical characteristics	12
Table 5.	Pin description	18
Table 6.	Typical application values	20
Table 7.	CL values according to external oscillator frequency	29
Table 8.	UVLO thresholds	32
Table 9.	Thermal protection summarizing table	33
Table 10.	Integrated MOSFETs characteristics at $T_j = 25\text{ }^\circ\text{C}$	34
Table 11.	Output slew rate	35
Table 12.	Register map	51
Table 13.	EL_POS register	53
Table 14.	MIN_SPEED register	55
Table 15.	FS_SPD register	55
Table 16.	Voltage amplitude regulation registers	56
Table 17.	Winding resistance thermal drift compensation coefficient	57
Table 18.	Torque regulation by TVAL_HOLD, TVAL_ACC, TVAL_DEC and TVAL_RUN registers	58
Table 19.	T_FAST register	58
Table 20.	Maximum fast decay times	59
Table 21.	Minimum on-time	59
Table 22.	Minimum off-time	60
Table 23.	ADC_OUT value and motor supply voltage compensation feature	60
Table 24.	ADC_OUT value and torque regulation feature	60
Table 25.	Overcurrent detection threshold	61
Table 26.	Stall detection threshold	61
Table 27.	STEP_MODE register	61
Table 28.	Control mode selection	61
Table 29.	Step mode selection	62
Table 30.	Sync clock enable	62
Table 31.	Sync clock selection	62
Table 32.	ALARM_EN register	63
Table 33.	GATECFG1 register	63
Table 34.	IGATE parameter	63
Table 35.	TCC parameter	64
Table 36.	TBOOST parameter	64
Table 37.	GATECFG2 register (voltage mode)	64
Table 38.	TDT parameter	65
Table 39.	TBLANK parameter	65
Table 40.	CONFIG register	66
Table 41.	Oscillator management	66
Table 42.	External switch hard stop interrupt mode	67
Table 43.	Overcurrent event	67
Table 44.	Programmable VCC voltage regulator output	67
Table 45.	Programmable UVLO thresholds	68
Table 46.	Motor supply voltage compensation enable	68
Table 47.	PWM frequency: integer division factor	68

Table 48.	PWM frequency: multiplication factor	69
Table 49.	Available PWM frequencies [kHz]: 8 MHz oscillator frequency	69
Table 50.	Available PWM frequencies [kHz]: 16 MHz oscillator frequency	69
Table 53.	External torque regulation enable	70
Table 51.	Available PWM frequencies [kHz]: 24 MHz oscillator frequency	70
Table 52.	Available PWM frequencies [kHz]: 32 MHz oscillator frequency	70
Table 54.	Motor supply voltage compensation enable	71
Table 55.	Switching period	71
Table 56.	STATUS register	71
Table 57.	STATUS register TH_STATUS bits	72
Table 58.	STATUS register DIR bit.	72
Table 59.	STATUS register MOT_STATUS bits	72
Table 60.	Application commands	73
Table 61.	Nop command structure	75
Table 62.	SetParam command structure	75
Table 63.	GetParam command structure	75
Table 64.	Run command structure	76
Table 65.	StepClock command structure	76
Table 66.	Move command structure	77
Table 67.	GoTo command structure	77
Table 68.	GoTo_DIR command structure	78
Table 69.	GoUntil command structure	78
Table 70.	ReleaseSW command structure	79
Table 71.	GoHome command structure	79
Table 72.	GoMark command structure	80
Table 73.	ResetPos command structure	80
Table 74.	ResetDevice command structure	80
Table 75.	SoftStop command structure	81
Table 76.	HardStop command structure	81
Table 77.	SoftHiZ command structure	81
Table 78.	HardHiZ command structure	82
Table 79.	GetStatus command structure	82
Table 80.	VFQFPN 11 x 14 x 1.0 - 9 die pads - 89 leads, , ,	86
Table 81.	Document revision history	91

List of figures

Figure 1.	Block diagram	9
Figure 2.	Pin connection (top view)	17
Figure 3.	Typical application schematic - voltage mode	21
Figure 4.	Typical application schematic - current mode.	21
Figure 5.	Charge pump circuitry.	23
Figure 6.	Normal mode and microstepping (128 microsteps)	23
Figure 7.	Automatic Full-step switching in Normal mode.	24
Figure 8.	Automatic Full-step switching in Boost mode	25
Figure 9.	Constant speed command examples	26
Figure 10.	Positioning command examples	27
Figure 11.	Motion command examples	27
Figure 12.	OSCIN and OSCOUT pin configuration	30
Figure 13.	Overcurrent detection - principle scheme	31
Figure 14.	External switch connection	34
Figure 15.	Device supply pin management	36
Figure 16.	Current distortion and compensation	40
Figure 17.	BEMF compensation curve.	41
Figure 18.	Motor supply voltage compensation circuit.	41
Figure 19.	Predictive current control	43
Figure 20.	Non-predictive current control.	44
Figure 21.	Adaptive decay - fast decay tuning	45
Figure 22.	Adaptive decay - switch from normal to slow+ fast decay mode and vice versa	46
Figure 23.	Fast decay tuning during the falling steps	47
Figure 24.	Current sensing and reference voltage generation.	48
Figure 25.	SPI timings diagram	49
Figure 26.	Daisy chain configuration	50
Figure 27.	Command with 3-byte argument.	74
Figure 28.	Command with 3-byte response	74
Figure 29.	Command response aborted	74
Figure 30.	VFQFPN 11 x 14 x 1.0 - 9 die pads drawing - side view	83
Figure 31.	VFQFPN 11 x 14 x 1.0 - 9 die pads drawing - bottom view	84
Figure 32.	VFQFPN 11 x 14 x 1.0 - 9 die pads drawing - pin identifier	85
Figure 33.	Recommended footprint - suggested landpattern (overall view)	87
Figure 34.	Recommended footprint - lead land positioning	88
Figure 35.	Recommended footprint - land size and exposed pad positioning	89
Figure 36.	Recommended footprint - detail A and B drawing	90

1 Block diagram

Figure 1. Block diagram

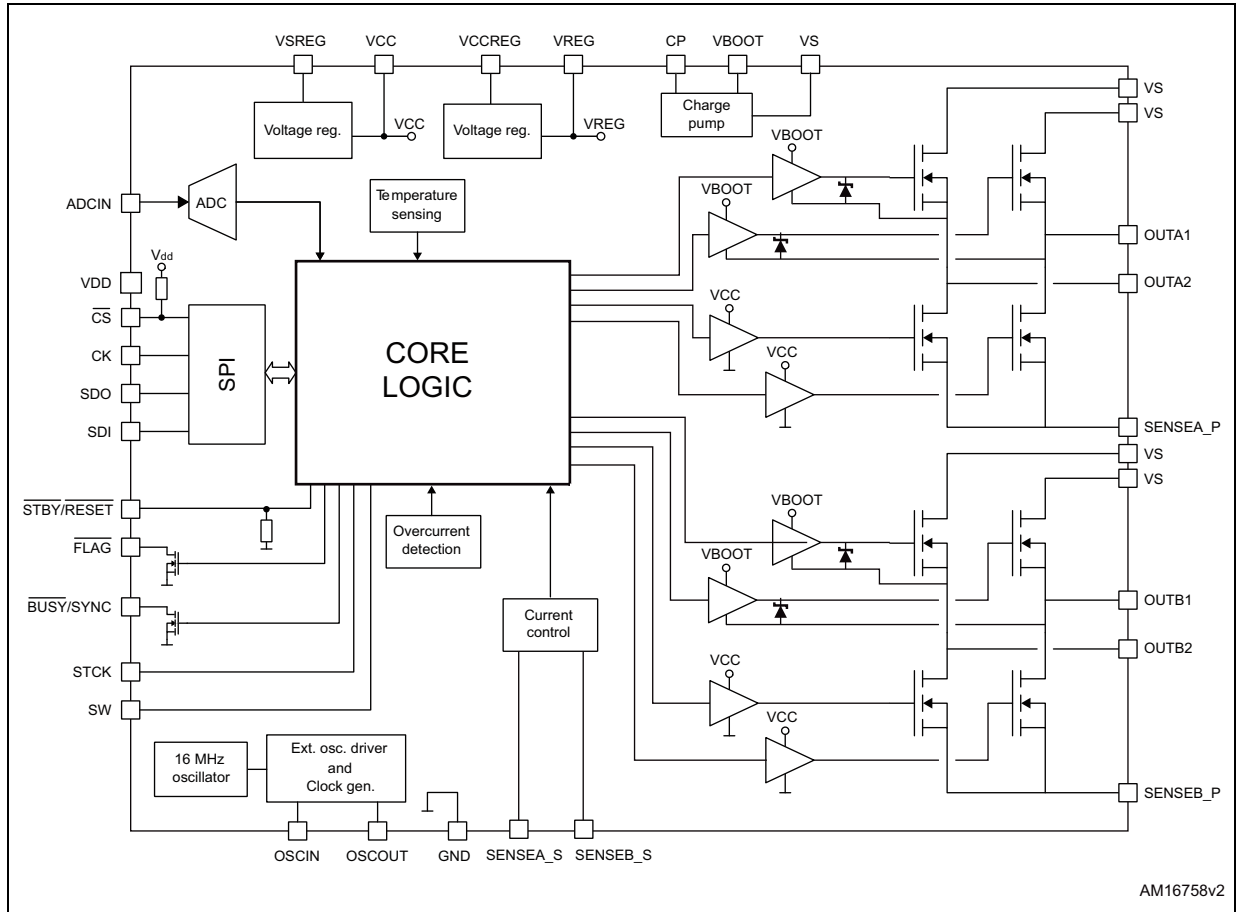

2 Electrical data

2.1 Absolute maximum ratings

Table 2. Absolute maximum ratings

Symbol	Parameter	Test conditions	Value	Unit
V_{DD}	Logic interface supply voltage		5.5	V
V_{REG}	Logic supply voltage		3.6	
V_S	Motor supply voltage		95	V
V_{CC}	Low-side gate driver supply voltage		18	V
V_{BOOT}	Boot voltage		100	V
ΔV_{BOOT}	High-side gate driver supply voltage ($V_{BOOT} - V_S$)		0 to 20	V
V_{SREG}	Internal V_{CC} regulator supply voltage		95	V
V_{CCREG}	Internal V_{REG} regulator supply voltage		18	V
V_{OUT1A} V_{OUT2A} V_{OUT1B} V_{OUT2B}	Output voltage	DC	-5 to V_{BOOT}	V
		AC	-15 to V_{BOOT}	
I_{OUT1A} I_{OUT2A} I_{OUT1B} I_{OUT2B}	Output current	DC	10	$A_{r.m.s.}$
SR_{out}	Full bridge output slew rate (10% - 90%)		10	V/ns
V_{ADCIN}	Integrated ADC input voltage range (ADCIN pin)		-0.3 to 3.6	V
V_{out_diff}	Differential voltage between VBOOT, VS, OUT1A, OUT2A, PGND and VBOOT, VS, OUT1B, OUT2B, PGND pins		100	V
V_{in}	Logic input voltage range		-0.3 to 5.5	V
T_{OP} T_S	Storage and operating junction temperature		-40 to 150	°C

2.2 Recommended operating conditions

Table 3. Recommended operating conditions

Symbol	Parameter	Test conditions	Min.	Typ.	Max.	Unit
V_{DD}	Logic interface supply voltage	3.3 V logic outputs		3.3		V
		5 V logic outputs		5		
V_{REG}	Logic supply voltage			3.3		V
V_S	Motor supply voltage		V_{SREG}		85	V
V_{SREG}	Internal V_{CC} voltage regulator supply voltage	V_{CC} voltage internally generated	$V_{CC} + 3$		V_S	V
$V_{CC, ext}$	Gate driver supply voltage	V_{CC} voltage imposed by external source ($V_{SREG} = V_{CC}$)	7.5		15	V
V_{CCREG}	Internal V_{REG} voltage regulator supply voltage	V_{REG} voltage internally generated	6.3		V_{CC}	V
V_{ADC}	Integrated ADC input voltage (ADCIN pin)		0		V_{REG}	V

3 Electrical characteristics

$V_S = 48\text{ V}$; $V_{CC} = 7.5\text{ V}$; $V_{DD} = 3.3\text{ V}$; $T_j = 25\text{ }^\circ\text{C}$, unless otherwise specified.

Table 4. Electrical characteristics

Symbol	Parameter	Test conditions	Min.	Typ.	Max.	Unit
General						
V_{CCthOn}	V_{CC} UVLO turn-on threshold	UVLO_VAL set high ⁽¹⁾	9.9	10.4	10.9	V
		UVLO_VAL set low ⁽¹⁾	6.5	6.9	7.3	V
$V_{CCthOff}$	V_{CC} UVLO turn-off threshold	UVLO_VAL set high ⁽¹⁾	9.5	10	10.5	V
		UVLO_VAL set low ⁽¹⁾	5.9	6.3	6.7	V
$\Delta V_{BOOTthOn}$	$V_{BOOT} - V_S$ UVLO turn-on threshold	UVLO_VAL set high ⁽¹⁾	8.6	9.2	9.94	V
		UVLO_VAL set low ⁽¹⁾	5.7	6	6.35	V
$\Delta V_{BOOTthOff}$	$V_{BOOT} - V_S$ UVLO turn-off threshold	UVLO_VAL set high ⁽¹⁾	8.2	8.8	9.65	V
		UVLO_VAL set low ⁽¹⁾	5.3	5.5	5.9	V
$V_{REGthOn}$	V_{REG} turn-on threshold	⁽¹⁾	2.8	3	3.18	V
$V_{REGthOff}$	V_{REG} turn-off threshold	⁽¹⁾	2.2	2.4	2.5	V
I_{VREGqu}	Undervoltage V_{REG} quiescent supply current	$V_{CCREG} = V_{REG} < 2.2\text{ V}$ ⁽¹⁾		40		μA
I_{VREGq}	Quiescent V_{REG} supply current	$V_{CCREG} = V_{REG} = 3.3\text{ V}$ internal oscillator selected ⁽¹⁾		3.8		mA
I_{VSREGq}	Quiescent V_{SREG} supply current	$V_{CCREG} = V_{CC} = 15\text{ V}$		6.5		mA
Thermal protection						
$T_{j(WRN)Set}$	Thermal warning temperature			135		$^\circ\text{C}$
$T_{j(WRN)Rec}$	Thermal warning recovery temperature			125		$^\circ\text{C}$
$T_{j(OFF)Set}$	Thermal bridge shutdown temperature			155		$^\circ\text{C}$
$T_{j(OFF)Rec}$	Thermal bridge shutdown recovery temperature			145		$^\circ\text{C}$
$T_{j(SD)Set}$	Thermal device shutdown temperature			170		$^\circ\text{C}$
$T_{j(SD)Rec}$	Thermal device shutdown recovery temperature			130		$^\circ\text{C}$
Charge pump						
V_{pump}	Voltage swing for charge pump oscillator			V_{CC}		V
$f_{pump,min}$	Minimum charge pump oscillator frequency ⁽²⁾			660		kHz
$f_{pump,max}$	Maximum charge pump oscillator frequency ⁽²⁾			800		kHz

Table 4. Electrical characteristics (continued)

Symbol	Parameter	Test conditions	Min.	Typ.	Max.	Unit
R_{pumpHS}	Charge pump high-side $R_{\text{DS(on)}}$ resistance			10		Ω
R_{pumpLS}	Charge pump low-side $R_{\text{DS(on)}}$ resistance			10		Ω
I_{boot}	Average boot current			2.6		mA
Power outputs						
$R_{\text{DS(on)}}$	High-side and low-side on resistance	$V_{\text{CC}} = 15 \text{ V}$ at $25 \text{ }^\circ\text{C}$		16	21	m Ω
		At $125 \text{ }^\circ\text{C}$		23		
SR_{OUT}	Output slew rate	$\text{IGATE} = 96 \text{ mA}$		980		V/ μs
		$\text{IGATE} = 32 \text{ mA}$		520		
I_{DSS}	Leakage current	$\text{OUT} = V_{\text{S}}$			0.1	mA
		$\text{OUT} = \text{GND}$	-0.1			mA
Deadtime and blanking						
t_{DT}	Programmable deadtime ²	TDT = '00000'		125		ns
		TDT = '11111'		4000		
t_{blank}	Programmable blanking time ²	TBLANK = '000'		125		ns
		TBLANK = '111'		1000		
Logic						
V_{IL}	Low level logic input voltage				0.8	V
V_{IH}	High level logic input voltage		2			V
I_{IH}	High level logic input current	$V_{\text{IN}} = 5 \text{ V}$, $V_{\text{DD}} = 5 \text{ V}$			1	μA
I_{IL}	Low level logic input current	$V_{\text{IN}} = 0 \text{ V}$, $V_{\text{DD}} = 5 \text{ V}$	-1			μA
V_{OL}	Low level logic output voltage ⁽³⁾	$V_{\text{DD}} = 3.3 \text{ V}$, $I_{\text{OL}} = 4 \text{ mA}$			0.3	V
		$V_{\text{DD}} = 5 \text{ V}$, $I_{\text{OL}} = 4 \text{ mA}$			0.3	
V_{OH}	High level logic output voltage	$V_{\text{DD}} = 3.3 \text{ V}$, $I_{\text{OH}} = 4 \text{ mA}$	2.4			V
		$V_{\text{DD}} = 5 \text{ V}$, $I_{\text{OH}} = 4 \text{ mA}$	4.7			
R_{PUCS}	CS pull-up resistor			430		k Ω
R_{PDRST}	STBY/RESET pull-down resistor			450		
R_{PUSW}	CS pull-up resistor			80		
$t_{\text{high,STCK}}$	Step-clock input high time		300			ns
$t_{\text{low,STCK}}$	Step-clock input low time		300			ns
Internal oscillator and external oscillator driver						
$f_{\text{osc,int}}$	Internal oscillator frequency	$T_{\text{j}} = 25 \text{ }^\circ\text{C}$	-5%	16	+5%	MHz
$f_{\text{osc,ext}}$	Programmable external oscillator frequency		8		32	MHz

Table 4. Electrical characteristics (continued)

Symbol	Parameter	Test conditions	Min.	Typ.	Max.	Unit
V _{OSCOUTH}	OSCOUT clock source high level voltage	Internal oscillator	2.4			V
V _{OSCOU_L}	OSCOUT clock source low level voltage	Internal oscillator			0.3	V
t _{rOSCOUT} t _{fOSCOUT}	OSCOUT clock source rise and fall time	Internal oscillator			10	ns
t _{high}	OSCOUT clock source high time	Internal oscillator		31.25		ns
t _{extosc}	Internal to external oscillator switching delay			3		ms
t _{intosc}	External to internal oscillator switching delay				100	μs
SPI						
f _{CK,MAX}	Maximum SPI clock frequency ⁽⁴⁾		5			MHz
t _{rCK} t _{fCK}	SPI clock rise and fall time ⁽⁴⁾				1	μs
t _{hCK} t _{lCK}	SPI clock high and low time ⁽⁴⁾		90			ns
t _{setCS}	Chip select setup time ⁽⁴⁾		30			ns
t _{holCS}	Chip select hold time ⁽⁴⁾		30			ns
t _{disCS}	Deselect time ⁽⁴⁾		625			ns
t _{setSDI}	Data input setup time ⁽⁴⁾		20			ns
t _{holSDI}	Data input hold time ⁽⁴⁾		30			ns
t _{enSDO}	Data output enable time ⁽⁴⁾				95	ns
t _{disSDO}	Data output disable time ⁽⁴⁾				95	ns
t _{vSDO}	Data output valid time ⁽⁴⁾				35	ns
t _{holSDO}	Data output hold time ⁽⁴⁾		0			ns
PWM modulators						
f _{PWM}	Programmable PWM frequency ⁽²⁾	f _{osc} = 32 MHz F_PWM_INT='11X' F_PWM_DEC='000'		5.6		kHz
		f _{osc} = 32 MHz F_PWM_INT='000' F_PWM_DEC='111'		125		kHz
N _{PWM}	PWM resolution			8		bit
Current control						
V _{REF, MAX}	Maximum reference voltage			1000		mV
V _{REF, MIN}	Minimum reference voltage			7.8		mV



Table 4. Electrical characteristics (continued)

Symbol	Parameter	Test conditions	Min.	Typ.	Max.	Unit
Overcurrent protection						
V_{OCD}	Programmable overcurrent detection voltage V_{DS} threshold	OCD_TH = '00000'	27	31	35	mV
		OCD_TH = '01001'	270	312.5	344	mV
		OCD_TH = '10011'	500	625	688	mV
		OCD_TH = '11111'	800	1000	1100	mV
$t_{OCD,Comp}$	OCD comparator delay		100	200	ns	
$t_{OCD,Flag}$	OCD to flag signal delay time		230	530	ns	
$t_{OCD,SD}$	OCD to shutdown delay time	$I_{gate} = 4 \text{ mA}$, $t_{CC} = \text{maximum}$		4200	6000	ns
Stall detection						
V_{STALL}	Programmable stall detection V_{DS} voltage threshold	STALL_TH = '11111'		1000		mV
		STALL_TH = '00000'		31		
Standby						
I_{STBY}	Standby mode supply current (VSREG pin)	$V_{CC} = V_{CCREG} = 7.5 \text{ V}$ $V_{SREG} = 48 \text{ V}$		42		μA
		$V_{CC} = V_{CCREG} = 7.5 \text{ V}$ $V_{SREG} = 18 \text{ V}$		37.5		
$I_{STBY,reg}$	Standby mode supply current (VREG pin)			6		μA
$t_{STBY,min}$	Minimum standby time			0.5		ms
$t_{logicwu}$	Logic power-on and wake-up time			500		μs
t_{cpwu}	Charge pump power-on and wake-up time	Power bridges disabled, $C_p = 10 \text{ nF}$, $C_{boot} = 220 \text{ nF}$, $V_{CC} = 15 \text{ V}$		1		ms
Internal voltage regulators						
V_{CCOUT}	Internal V_{CC} voltage regulator output voltage	Low (default), $I_{CC} = 10 \text{ mA}$	7.3	7.5		V
		High, $I_{CC} = 10 \text{ mA}$	14	15		
$V_{SREG, drop}$	V_{SREG} to V_{CC} dropout voltage	$I_{CC} = 50 \text{ mA}$			3	V
P_{CC}	Internal V_{CC} voltage regulator power dissipation				2.5	W
V_{REGOUT}	Internal V_{REG} voltage regulator output voltage	$I_{REG} = 10 \text{ mA}$	3.13 5	3.3		V
$V_{CCREG, drop}$	V_{CCREG} to V_{REG} dropout voltage	$I_{REG} = 50 \text{ mA}$			3	V
I_{REGOUT}	Internal V_{REG} voltage regulator output current			125		mA

Table 4. Electrical characteristics (continued)

Symbol	Parameter	Test conditions	Min.	Typ.	Max.	Unit
$I_{REGOUT,STBY}$	Internal V_{REG} voltage regulator output standby current			55		mA
P_{REG}	Internal V_{REG} voltage regulator power dissipation				0.5	W
Integrated analog to digital converter						
N_{ADC}	Analog to digital converter resolution			5		bit
$V_{ADC,ref}$	Analog to digital converter reference voltage			3.3		V
f_S	Analog to digital converter sampling frequency	Voltage mode ⁽²⁾		f_{PWM}		kHz
		Current mode ⁽²⁾		$f_{OSC}/512$		kHz
$V_{ADC,UVLO}$	ADCIN UVLO threshold		1.05	1.16	1.35	V

1. Guaranteed in the temperature range -25 to 125 °C.
2. The value accuracy is dependent on oscillator frequency accuracy ([Section 7.8 on page 29](#)).
3. \overline{FLAG} and \overline{BUSY} open-drain outputs included.
4. See [Figure 25 on page 49](#).

4 Pin connection

Figure 2. Pin connection (top view)

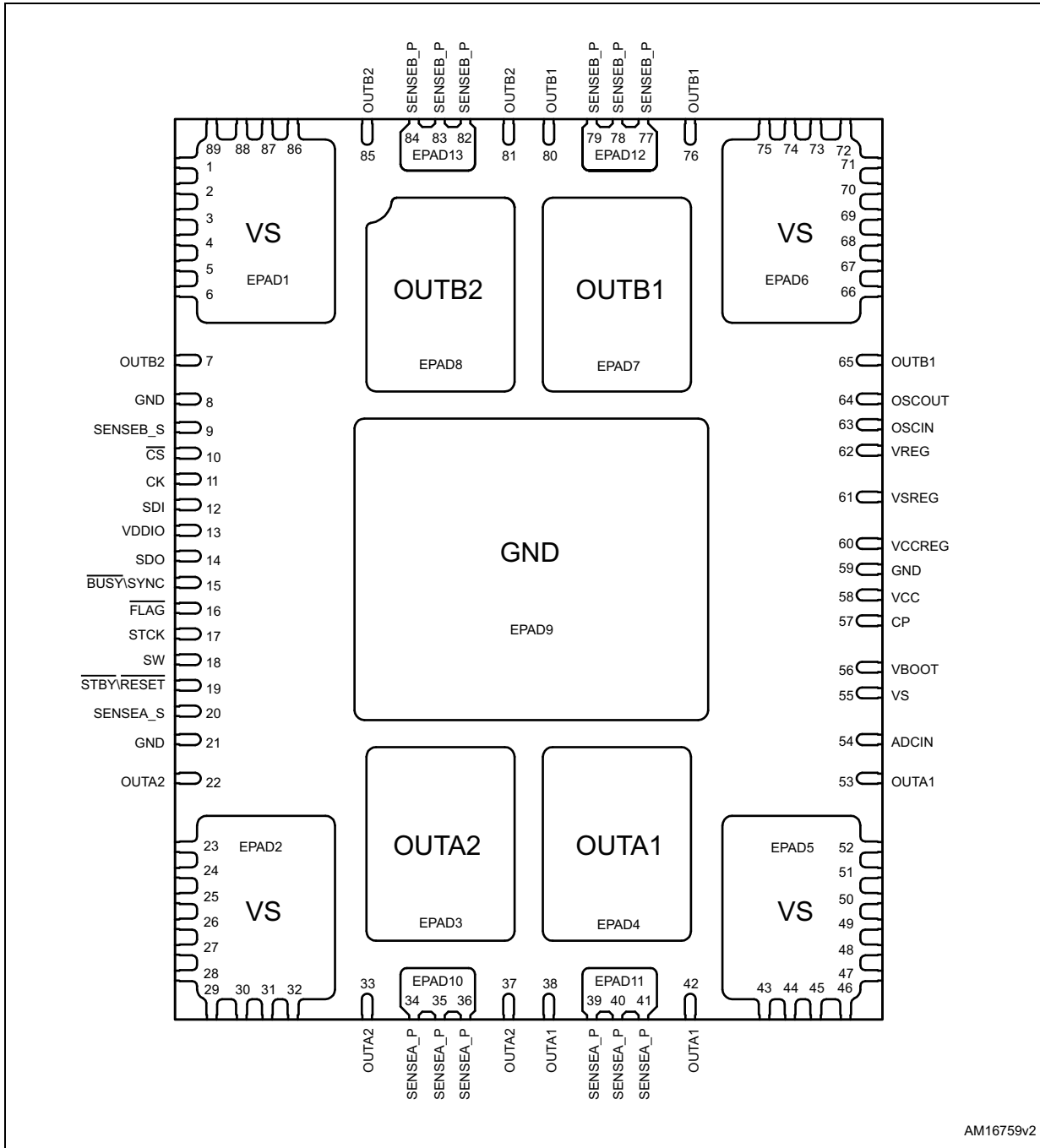

5 Pin list

Table 5. Pin description

No.	Name	Type	Function
1, 2, 3, 4, 5, 6, 23, 24, 25, 26, 27, 28, 29, 30, 31, 32, 43, 44, 45, 46, 47, 48, 49, 50, 51, 52, 66, 67, 68, 69, 70, 71, 72, 73, 74, 75, 86, 87, 88, 89, EPAD1, EPAD2, EPAD5, EPAD6	VS	Supply	Motor supply voltage (drain of the high-side MOSFETs)
38, 42, 53, EPAD4	OUTA1	Power output	Half-bridge A1 output
22, 33, 37, EPAD3	OUTA2	Power output	Half-bridge A2 output
65, 76, 80, EPAD7	OUTB1	Power output	Half-bridge B1 output
7, 81, 85, EPAD8	OUTB2	Power output	Half-bridge B2 output
8, 21, 59, EPAD9	GND	Ground	Ground
34, 35, 36, 39, 40, 41, EPAD10, EPAD11	SENSEA_P	Sense (power)	Tail of full bridge A (source of the respective low-side MOSFETs)
20	SENSEA_S	Analog input	Current control comparator input
77, 78, 79, 82, 83, 84, EPAD12, EPAD13	SENSEB_P	Sense (power)	Tail of full bridge B (source of the respective low-side MOSFETs)
9	SENSEB_S	Analog input	Current control comparator input
60	VCCREG	Power supply	Internal V_{REG} voltage regulator supply voltage
62	VREG	Power supply	Logic supply voltage
13	VDDIO	Power supply	Logic interface supply voltage
61	VSREG	Power supply	Internal V_{CC} voltage regulator supply voltage
58	VCC	Power supply	Gate driver supply voltage
63	OSCIN	Analog input	Oscillator pin 1. To connect an external oscillator or clock source.
64	OSCOUT	Analog output	Oscillator pin 2. To connect an external oscillator. When the internal oscillator is used this pin can supply a 2/4/8/16 MHz clock.
57	CP	Output	Charge pump oscillator output
56	VBOOT	Power supply	Bootstrap voltage needed for driving the high-side power DMOS of both bridges (A and B).
54	ADCIN	Analog input	Internal analog to digital converter input
55	VS	Power supply	Motor supply voltage
18	SW	Logical input	External switch input pin
14	SDO	Logic output	Data output pin for serial interface

Table 5. Pin description (continued)

No.	Name	Type	Function
12	SDI	Logic input	Data input pin for serial interface
11	CK	Logic input	Serial interface clock
10	CS	Logic input	Chip select input pin for serial interface
15	BUSY /SYNC	Open-drain output	By default BUSY/SYNC pin is forced low when the device is performing a command. The pin can be programmed in order to generate a synchronization signal.
16	FLAG	Open-drain output	Status flag pin. An internal open-drain transistor can pull the pin to GND when a programmed alarm condition occurs (step loss, OCD, thermal pre-warning or shutdown, UVLO, wrong command, non performable command).
19	STBY /RESET	Logic input	Standby and reset pin. LOW logic level puts the device in standby mode and reset logic. If not used, should be connected to V_{REG}
17	STCK	Logic input	Step clock input.

6 Typical applications

Table 6. Typical application values

Name	Value
C_{VSPOL}	220 μ F
C_{VS}	220 nF
C_{BOOT}	470 nF
C_{FLY}	47 nF
C_{VSREG}	100 nF
C_{VCC}	470 nF
C_{VCCREG}	100 nF
C_{VREG}	100 nF
$C_{VREGPOL}$	22 μ F
C_{VDD}	100 nF
D1	Charge pump diodes
R_{PU}	39 k Ω
R_A	1.8 k Ω ($V_S = 85$ V)
R_B	91 k Ω ($V_S = 85$ V)
R_{SENSEA}	0.1 Ω (maximum $I_{peak} = 10$ A)
R_{SENSEB}	0.1 Ω (maximum $I_{peak} = 10$ A)

Figure 3. Typical application schematic - voltage mode

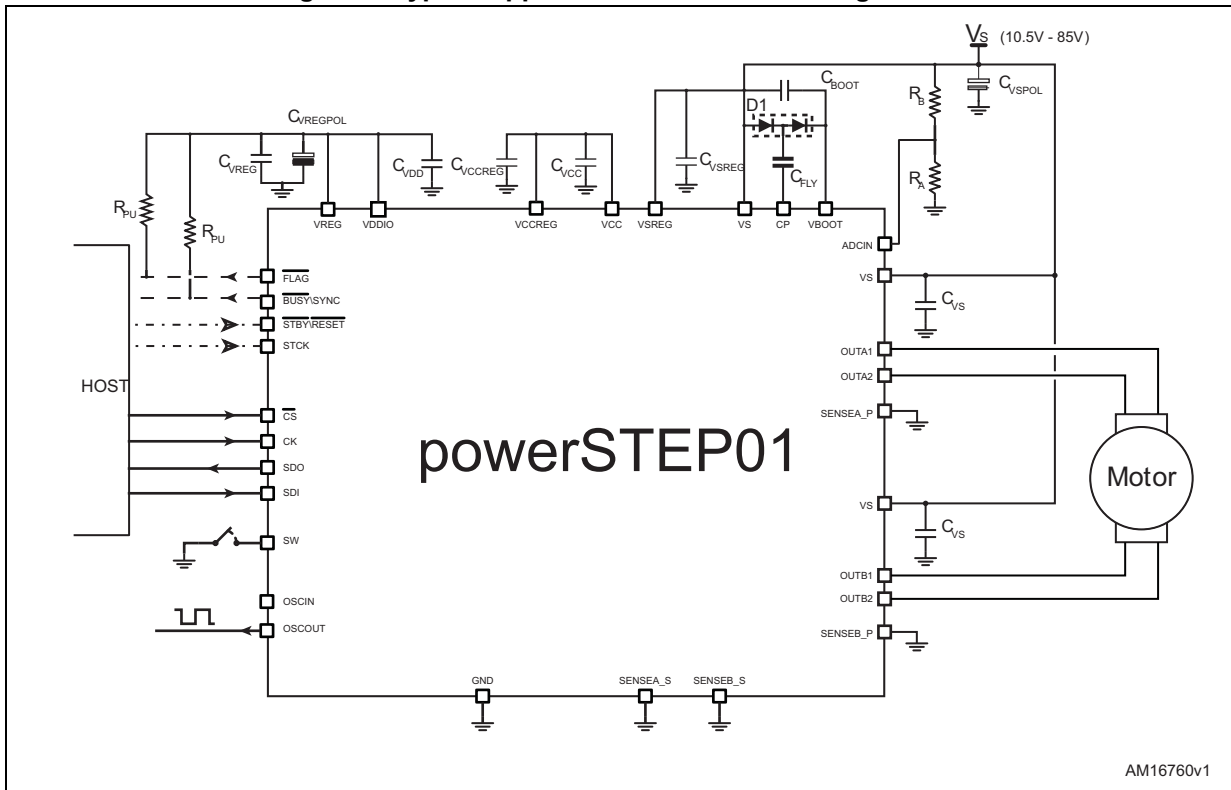
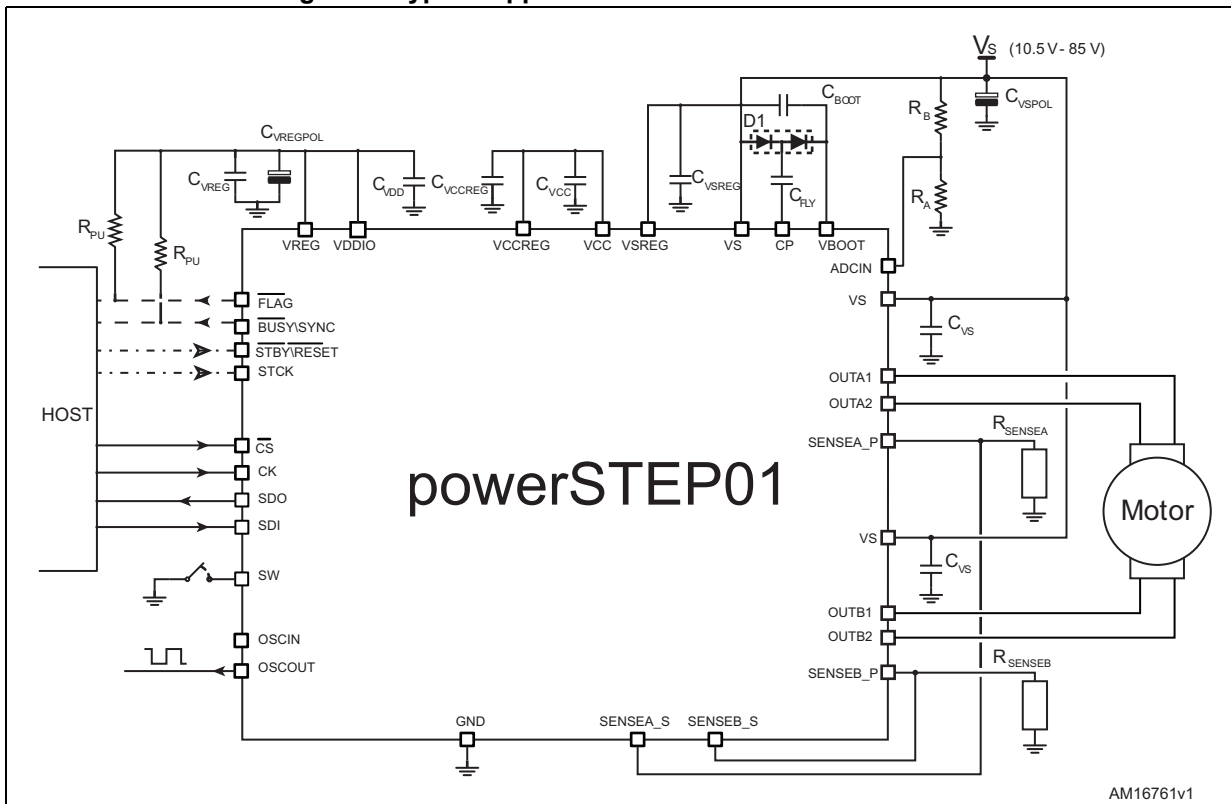

Figure 4. Typical application schematic - current mode



7 Functional description

7.1 Device power-up

During power-up, the device is under reset (all logic IOs disabled and power bridges in high impedance state) until the following conditions are satisfied:

- V_{REG} is greater than $V_{REGthOn}$
- Internal oscillator is operative
- $\overline{STBY/RESET}$ input is forced high.

After power-up, the device state is the following:

- Parameters are set to default
- Internal logic is driven by internal oscillator and a 2-MHz clock is provided by the OSCOUT pin
- Bridges are disabled (high impedance).
- FLAG output is forced low (UVLO failure indication).

After power-up, a period of $t_{logicwu}$ must pass before applying a command to allow proper oscillator and logic startup.

Any movement command makes the device exit from High Z state (HardStop and SoftStop included).

7.2 Logic I/O

Pins \overline{CS} , CK, SDI, STCK, SW and $\overline{STBY/RESET}$ are TTL/CMOS 3.3 V to 5 V compatible logic inputs.

Pin SDO is a TTL/CMOS compatible logic output. VDD pin voltage imposes logical output voltage range.

Pins \overline{FLAG} and $\overline{BUSY/SYNC}$ are open-drain outputs.

SW and \overline{CS} inputs are internally pulled up to V_{DD} and $\overline{STBY/RESET}$ input is internally pulled down to ground.

7.3 Charge pump

To ensure the correct driving of the high-side integrated MOSFETs, a voltage higher than the motor power supply voltage needs to be applied to the VBOOT pin. The high-side gate driver supply voltage V_{BOOT} is obtained through an oscillator and a few external components realizing a charge pump (see [Figure 5](#)).

Figure 5. Charge pump circuitry

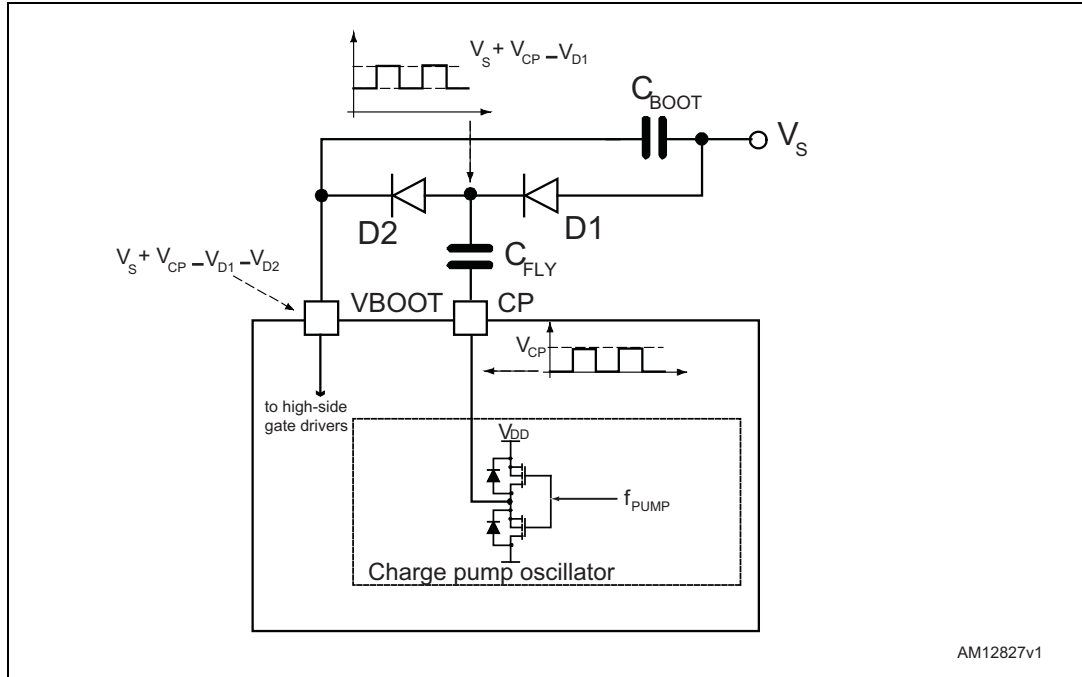

AM12827v1

7.4 Microstepping

The driver is able to divide the single step into up to 128 microsteps. Stepping mode can be programmed by the STEP_SEL parameter in the STEP_MODE register (Table 27 on page 61). In current mode driving the maximum microstepping resolution is 1/16th of the step.

Step mode can only be changed when bridges are disabled. Every time the step mode is changed, the electrical position (i. e. the point of microstepping sinewave that is generated) is reset to zero and the absolute position counter value (Section 7.5) becomes meaningless.

Figure 6. Normal mode and microstepping (128 microsteps)

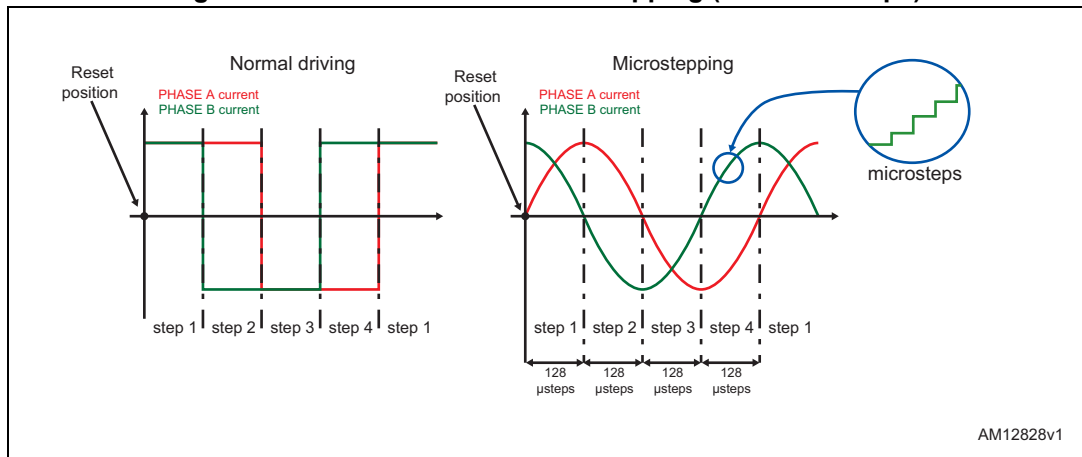

AM12828v1

Automatic Full-step and Boost modes

When motor speed is greater than a programmable full-step speed threshold, the device switches automatically to Full-step mode; the driving mode returns to microstepping when motor speed decreases below the full-step speed threshold.

The switching between the microstepping and Full-step mode and vice-versa is always performed at an electrical position multiple of $\pi/4$ (Figure 7 and Figure 8).

Full-step speed threshold is set through the related parameter in the FS_SPD register (Section 11.1.9 on page 55).

When the BOOST_MODE bit of the FS_SPD register is low (default), the amplitude of the voltage squarewave in Full-step mode is equal to the peak of the voltage sinewave multiplied by $\sin(\pi/4)$ (Figure 7). This avoids the current drop between the two driving modes.

When the BOOST_MODE bit of the FS_SPD register is high, the amplitude of the voltage squarewave in Full-step mode is equal to the peak of the voltage sinewave (Figure 8). That improves the output current increasing the maximum motor torque.

Figure 7. Automatic Full-step switching in Normal mode

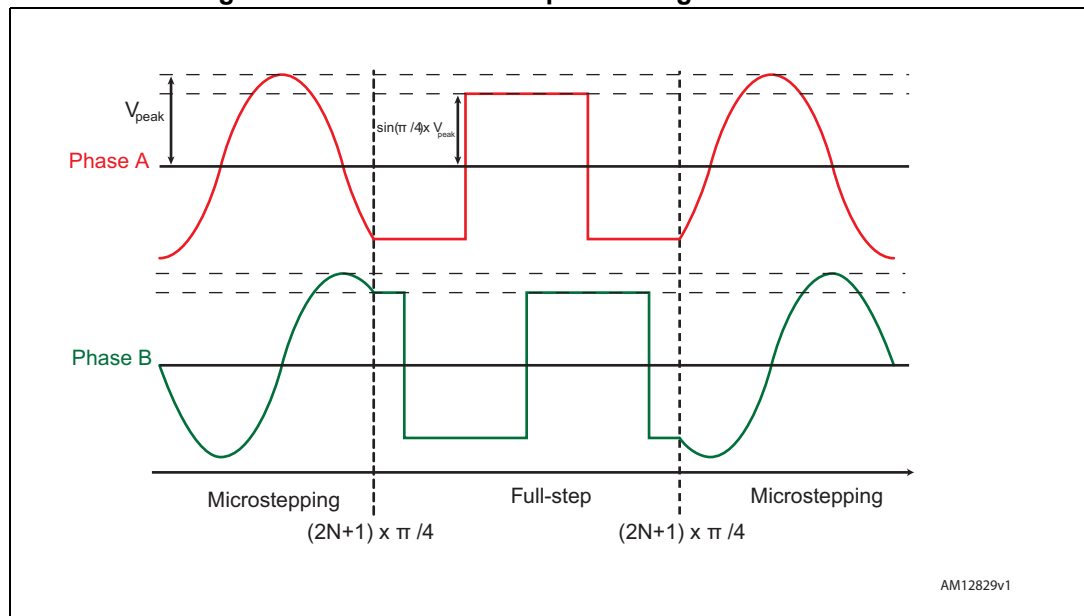
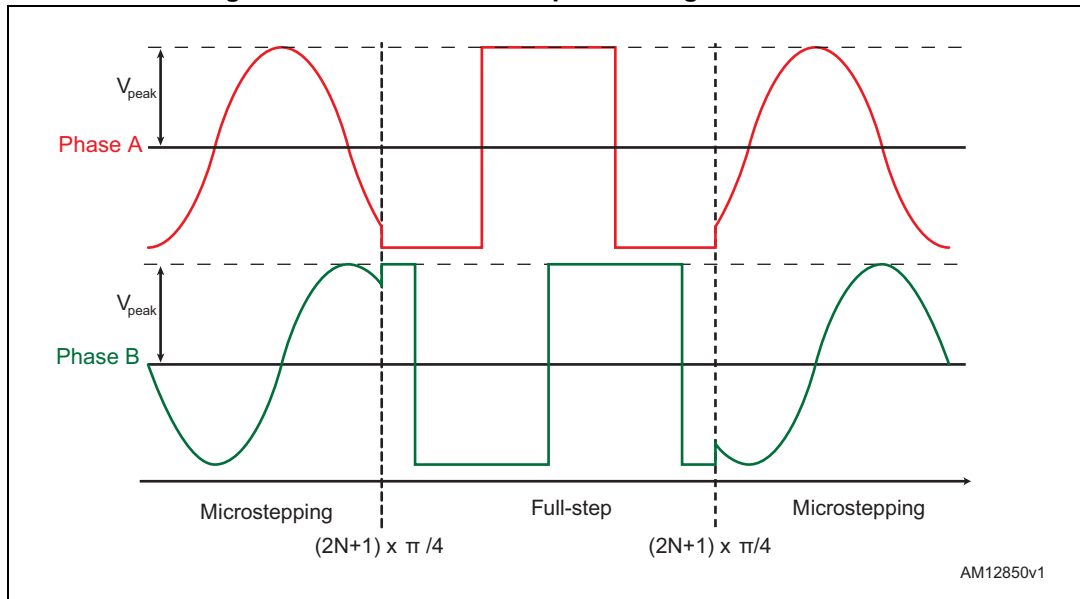

Figure 8. Automatic Full-step switching in Boost mode



7.5 Absolute position counter

An internal 22-bit register (ABS_POS) records all the motor motions according to the selected step mode; the stored value unit is equal to the selected step mode (full, half, quarter, etc.). The position range is from -2^{21} to $+2^{21}-1$ steps (see [Section 11.1.1 on page 53](#)).

7.6 Programmable speed profiles

The user can easily program a customized speed profile defining independently acceleration, deceleration, maximum and minimum speed values by ACC, DEC, MAX_SPEED and MIN_SPEED registers respectively (see [Section 11.1.5 on page 54](#), [11.1.6 on page 54](#), [11.1.7 on page 54](#) and [11.1.8 on page 55](#)).

When a command is sent to the device, the integrated logic generates the microstep frequency profile that performs a motor motion compliant to speed profile boundaries.

All acceleration parameters are expressed in $\text{step}/\text{tick}^2$ and all speed parameters are expressed in step/tick ; the unit of measurement does not depend on the selected step mode. Acceleration and deceleration parameters range from 2^{-40} to $(2^{12}-2) \cdot 2^{-40}$ $\text{step}/\text{tick}^2$ (equivalent to 14.55 to 59590 step/s^2).

Minimum speed parameter ranges from 0 to $(2^{12}-1) \cdot 2^{-24}$ step/tick (equivalent to 0 to 976.3 step/s).

Maximum speed parameter ranges from 2^{-18} to $(2^{10}-1) \cdot 2^{-18}$ step/tick (equivalent to 15.25 to 15610 step/s).

7.7 Motor control commands

The powerSTEP01 can accept different types of commands:

- constant speed commands (Run, GoUntil, ReleaseSW)
- absolute positioning commands (GoTo, GoTo_DIR, GoHome, GoMark)
- motion commands (Move)
- stop commands (SoftStop, HardStop, SoftHiz, HardHiz).

For detailed command descriptions refer to [Section 11.2 on page 73](#).

7.7.1 Constant speed commands

A constant speed command produces a motion in order to reach and maintain a user-defined target speed starting from the programmed minimum speed (set in the MIN_SPEED register) and with the programmed acceleration/deceleration value (set in the ACC and DEC registers). A new constant speed command can be requested anytime.

Figure 9. Constant speed command examples

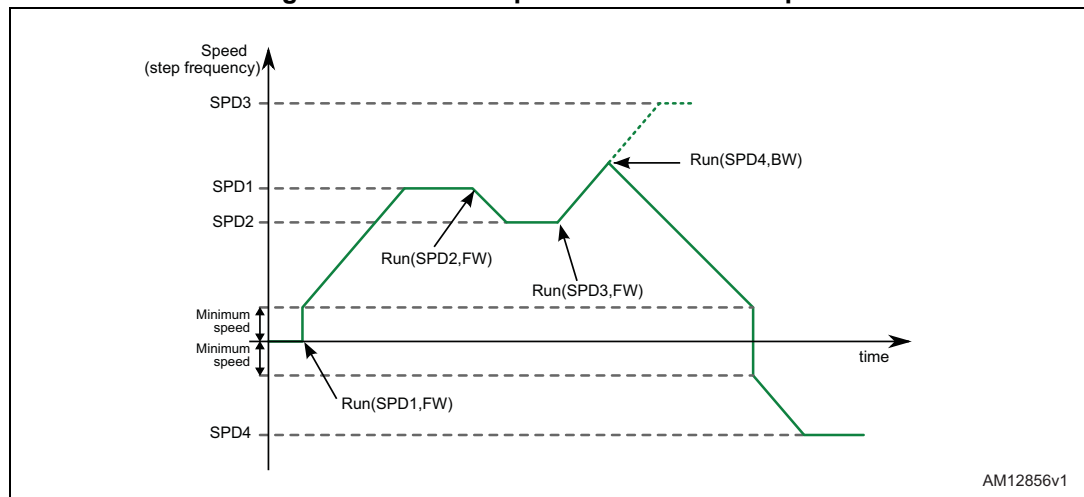

7.7.2 Positioning commands

An absolute positioning command produces a motion in order to reach a user-defined position that is sent to the device together with the command. The position can be reached performing the minimum path (minimum physical distance) or forcing a direction (see [Figure 10](#)).

Performed motor motion is compliant to programmed speed profile boundaries (acceleration, deceleration, minimum and maximum speed).

Note that with some speed profiles or positioning commands, the deceleration phase can start before the maximum speed is reached.

Figure 10. Positioning command examples

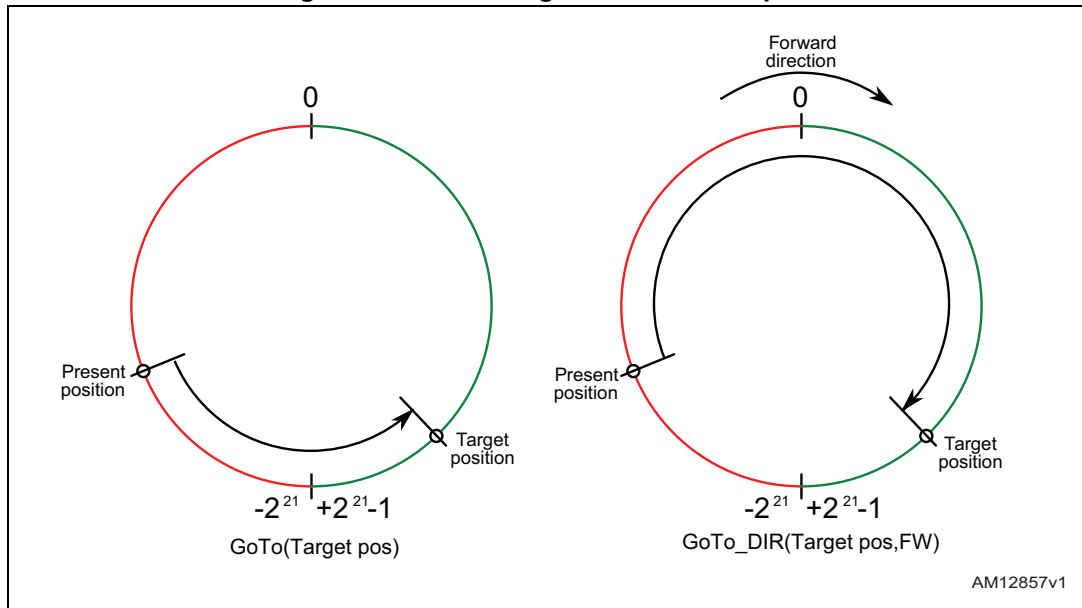

7.7.3 Motion commands

Motion commands produce a motion in order to perform a user-defined number of microsteps in a user-defined direction that are sent to the device together with the command (see [Figure 11](#)).

Performed motor motion is compliant to programmed speed profile boundaries (acceleration, deceleration, minimum and maximum speed).

Note that with some speed profiles or motion commands, the deceleration phase can start before the maximum speed is reached.

Figure 11. Motion command examples

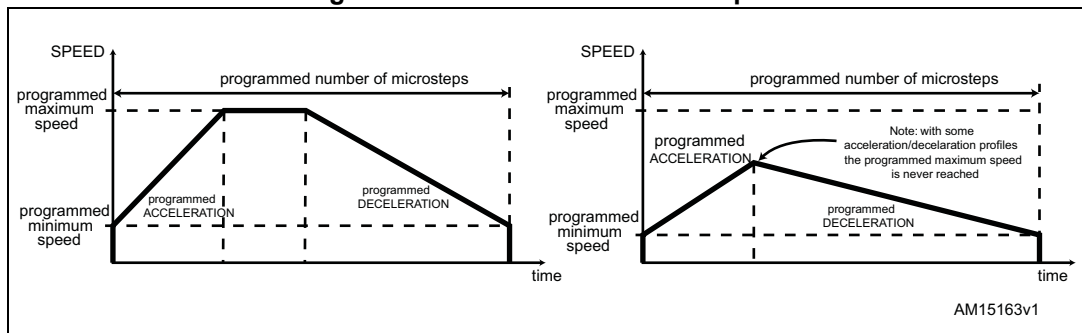

7.7.4 Stop commands

A stop command forces the motor to stop. Stop commands can be sent anytime.

The SoftStop command causes the motor to decelerate with a programmed deceleration value until MIN_SPEED value is reached and then stops the motor keeping the rotor position (a holding torque is applied).

The HardStop command stops the motor instantly, ignoring deceleration constraints and keeping the rotor position (a holding torque is applied).

The SoftHiZ command causes the motor to decelerate with a programmed deceleration value until the MIN_SPEED value is reached and then forces the bridges into high impedance state (no holding torque is present).

The HardHiZ command instantly forces the bridges into high impedance state (no holding torque is present).

7.7.5 Step-clock mode

In Step-clock mode the motor motion is defined by the step-clock signal applied to the STCK pin. At each step-clock rising edge, the motor is moved one microstep in the programmed direction and absolute position is consequently updated.

When the system is in Step-clock mode the SCK_MOD flag in the STATUS register is raised, the SPEED register is set to zero and motor status is considered stopped regardless of the STCK signal frequency (the MOT_STATUS parameter in the STATUS register equal to "00").

7.7.6 GoUntil and ReleaseSW commands

In most applications the power-up position of the stepper motor is undefined, so an initialization algorithm driving the motor to a known position is necessary.

The GoUntil and ReleaseSW commands can be used in combination with external switch input (see [Section 7.14 on page 33](#)) to easily initialize the motor position.

The GoUntil command makes the motor run at target constant speed until the SW input is forced low (falling edge). When this event occurs, one of the following actions can be performed:

- ABS_POS register is set to zero (home position) and the motor decelerates to zero speed (as a SoftStop command)
- ABS_POS register value is stored in the MARK register and the motor decelerates to zero speed (as a SoftStop command).

If the SW_MODE bit of the CONFIG register is set to '0', the motor does not decelerate but it immediately stops (as a HardStop command).

The ReleaseSW command makes the motor run at a programmed minimum speed until the SW input is forced high (rising edge). When this event occurs, one of the following actions can be performed:

- ABS_POS register is set to zero (home position) and the motor immediately stops (as a HardStop command)
- ABS_POS register value is stored in the MARK register and the motor immediately stops (as a HardStop command).

If the programmed minimum speed is less than 5 step/s, the motor is driven at 5 step/s.

7.8 Internal oscillator and oscillator driver

The control logic clock can be supplied by the internal 16-MHz oscillator, an external oscillator (crystal or ceramic resonator) or a direct clock signal.

These working modes can be selected by EXT_CLK and OSC_SEL parameters in the CONFIG register (see [Table 41 on page 66](#)).

At power-up the device starts using the internal oscillator and provides a 2-MHz clock signal on the OSCOUT pin.

Attention: In any case, before changing clock source configuration, a hardware reset is mandatory. Switching to different clock configurations during operation may cause unexpected behavior.

7.8.1 Internal oscillator

In this mode the internal oscillator is activated and OSCIN is unused. If the OSCOUT clock source is enabled, the OSCOUT pin provides a 2, 4, 8 or 16-MHz clock signal (according to OSC_SEL value); otherwise it is unused (see [Figure 12](#)).

7.8.2 External clock source

Two types of external clock source can be selected: crystal/ceramic resonator or direct clock source. Four programmable clock frequencies are available for each external clock source: 8, 16, 24 and 32-MHz.

When an external crystal/resonator is selected, the OSCIN and OSCOUT pins are used to drive the crystal/resonator (see [Figure 12](#)). The crystal/resonator and load capacitors (C_L) must be placed as close as possible to the pins. Refer to [Table 7](#) for the choice of the load capacitor value according to the external oscillator frequency.

Table 7. CL values according to external oscillator frequency

Crystal/resonator freq. ⁽¹⁾	C_L ⁽²⁾
8 MHz	25 pF ($ESR_{max} = 80 \Omega$)
16 MHz	18 pF ($ESR_{max} = 50 \Omega$)
24 MHz	15 pF ($ESR_{max} = 40 \Omega$)
32 MHz	10 pF ($ESR_{max} = 40 \Omega$)

1. First harmonic resonance frequency.
2. Lower ESR value allows driving greater load capacitors.

If a direct clock source is used, it must be connected to the OSCIN pin and the OSCOUT pin supplies the inverted OSCIN signal (see [Figure 12](#)).

The powerSTEP01 integrates a clock detection system that resets the device in case of the failure of the external clock source (direct or crystal/resonator). The monitoring of the clock source is disabled by default, it can be enabled setting high the WD_EN bit in the

GATECFG1 register ([Section 11.1.25 on page 63](#)). When the external clock source is selected, the device continues to work with the integrated oscillator for t_{extosc} milliseconds and then the clock management system switches to the OSCIN input.

Figure 12. OSCIN and OSCOUT pin configuration

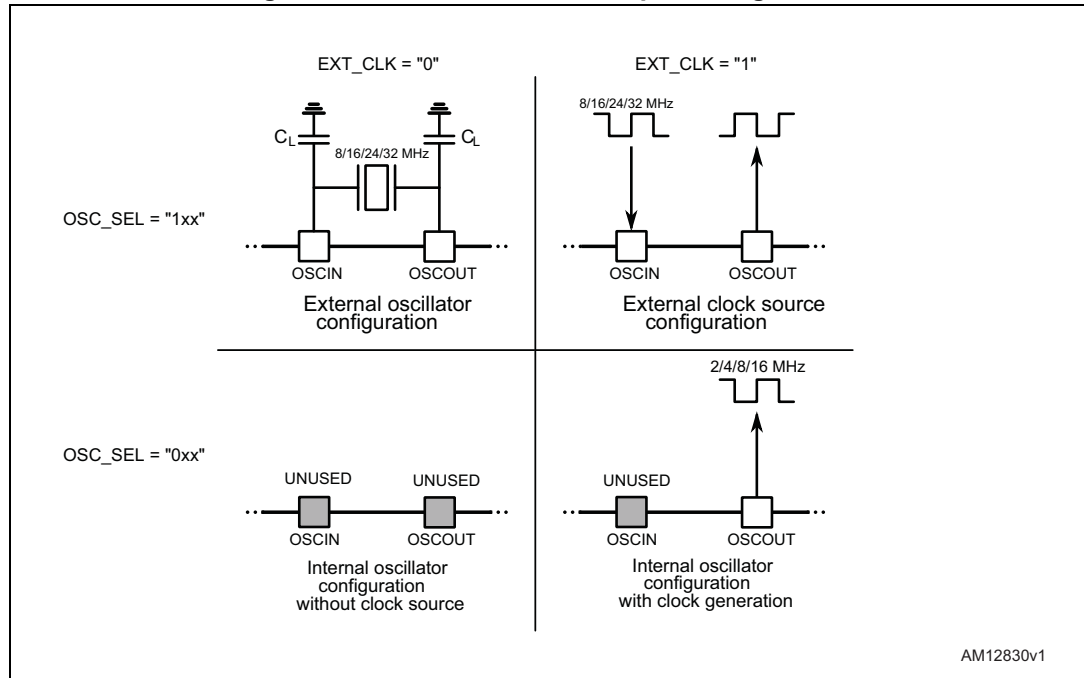

Note: When OSCIN is UNUSED, it should be left floating.
 When OSCOUT is UNUSED, it should be left floating.

7.9 Overcurrent detection

The powerSTEP01 measures the load current of each half-bridge sensing the V_{DS} voltage of the integrated MOSFET ([Figure 13](#)). When any of the V_{DS} voltages rise over the programmed threshold, the OCD flag in the STATUS register is forced low until the event expires and a GetStatus command is sent to the device ([Section 11.1.28 on page 71](#) and [Section 11.2.20 on page 82](#)). The overcurrent event expires when all the MOSFET V_{DS} voltages fall below the programmed threshold.

The overcurrent threshold can be programmed by the OCD_TH register in one of 32 available values listed in [Table 25 on page 61](#).

Figure 13. Overcurrent detection - principle scheme

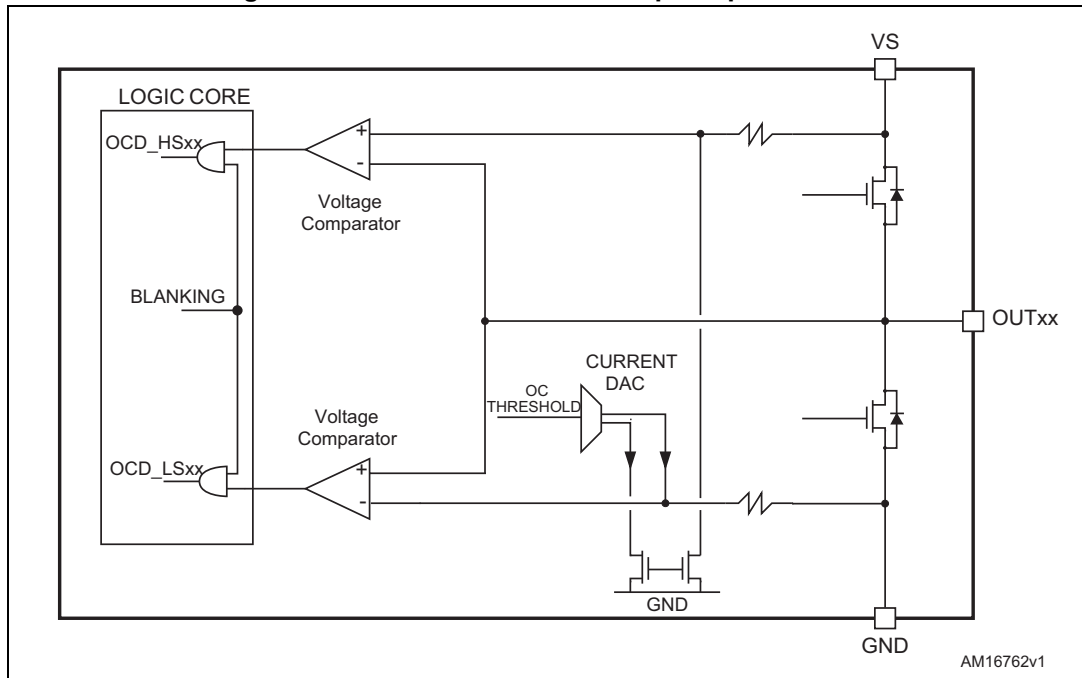

The overcurrent detection comparators are disabled, in order to avoid wrong voltage measurements, in following cases:

- The respective half-bridge is in high impedance state (both MOSFETs forced off);
- The respective half-bridge is commutating;
- The respective half-bridge is commutated and the programmed blanking time is not elapsed yet;
- The respective gate is turned off.

It is possible to set if an overcurrent event causes the bridges turn-off or not through the OC_SD bit in CONFIG register.

When the power bridges are turned off by an overcurrent event, they cannot be turned on until the OCD flag is released by a GetStatus command.

7.10 Undervoltage lockout (UVLO)

The powerSTEP01 provides a programmable gate driver supply voltage UVLO protection. When one of the supply voltages of the gate driver (V_{CC} for the low-sides and $V_{BOOT} - V_S$ for the high-sides) falls below the respective turn-off threshold, an undervoltage event occurs. In this case, all MOSFETs are immediately turned off and the UVLO flag in the STATUS register is forced low.

The UVLO flag is forced low and the MOSFETs are kept off until the gate driver supply voltages return to above the respective turn-on threshold; in this case the undervoltage event expires and the UVLO flag can be released through a GetStatus command.

The UVLO thresholds can be selected between two sets according to the UVLOVAL bit value in the CONFIG register.

Table 8. UVLO thresholds

	UVLOVAL	
	0	1
Low-side gate driver supply turn-off threshold ($V_{CCthOff}$)	6.3 V	10 V
Low-side gate driver supply turn-on threshold (V_{CCthOn})	6.9 V	10.4 V
High-side gate driver supply turn-off threshold ($\Delta V_{BOOTthOff}$)	5.5 V	8.8 V
High-side gate driver supply turn-on threshold ($\Delta V_{BOOTthOn}$)	6 V	9.2 V

7.11 V_S undervoltage lockout (UVLO_ADC)

The device provides an undervoltage signal of the integrated ADC input voltage (the UVLO_ADC flag in the STATUS register). When V_{ADCIN} falls below the $V_{ADC,UVLO}$ value the UVLO_ADC flag is forced low and it is kept in this state until the ADCIN voltage is greater than $V_{ADC,UVLO}$ and a GetStatus command is sent to the device.

The ADCIN undervoltage event doesn't turn-off the power bridges.

The motor supply voltage undervoltage detection can be performed by means of this feature, connecting the ADCIN pin to V_S through a voltage divider as described in [Section 8.5 on page 41](#).

7.12 Thermal warning and thermal shutdown

An integrated sensor allows detection of the internal temperature and implementation of a 3-level protection.

When the $T_{j(WRN)Set}$ threshold is reached, a warning signal is generated. This is the thermal warning condition and it expires when the temperature falls below the $T_{j(WRN)Rel}$ threshold.

When the $T_{j(OFF)Set}$ threshold is reached, all the MOSFETs are turned off and the gate driving circuitry is disabled (Miller clamps are still operative). This condition expires when the temperature falls below the $T_{j(OFF)Rel}$ threshold.

When the $T_{j(SD)OFF}$ threshold is reached, all the MOSFETs are turned off using Miller clamps, the internal V_{CC} voltage regulator is disabled and the current capability of the internal V_{REG} voltage regulator is reduced (thermal shutdown). In this condition logic is still active (if supplied). The thermal shutdown condition only expires when the temperature goes below $T_{j(SD)ON}$.

The thermal condition of the device is shown by TH_STATUS bits in the STATUS register ([Table 9](#)).

Table 9. Thermal protection summarizing table

State	Set condition	Release condition	Description	TH_STATUS
Normal			Normal operation state.	00
Warning	$T_j > T_{j(WRN)Set}$	$T_j < T_{j(WRN)Rel}$	Temperature warning: operation is not limited.	01
Bridge shutdown	$T_j > T_{j(OFF)Set}$	$T_j < T_{j(OFF)Rel}$	High temperature protection: the MOSFETs are turned off and the gate drivers are disabled.	10
Device shutdown	$T_j > T_{j(SD)Set}$	$T_j < T_{j(SD)Rel}$	Overtemperature protection: the MOSFETs are turned off, the gate drivers are disabled, the internal V_{CC} voltage regulator is disabled, the current capability of the internal V_{REG} voltage regulator is limited, and the charge pump is disabled.	11

7.13 Reset and standby

The device can be reset and put into Standby mode through the $\overline{STBY/RESET}$ pin. When it is forced low, all the MOSFETs are turned off (High Z state), the charge pump is stopped, the SPI interface and control logic are disabled and the internal V_{REG} voltage regulator maximum output current is limited; as a result, the powerSTEP01 heavily reduces the power consumption. At the same time the register values are reset to their default and all the protection functions are disabled. The $\overline{STBY/RESET}$ input must be forced low at least for $t_{STBY,min}$ in order to ensure the complete switch to Standby mode.

On exiting Standby mode, as well as for IC power-up, a delay must be given before applying a new command to allow proper oscillator and charge pump startup. Actual delay could vary according to the values of the charge pump external components.

On exiting Standby mode all the MOSFETs are off and the HiZ flag is high.

The registers can be reset to the default values without putting the device into Standby mode through the ResetDevice command ([Section 11.2.14 on page 80](#)).

7.14 External switch (SW pin)

The SW input is internally pulled up to V_{DD} and detects if the pin is open or connected to ground (see [Figure 14](#)).

The SW_F bit of the STATUS register indicates if the switch is open ('0') or closed ('1') ([Section 11.1.28 on page 71](#)); the bit value is refreshed at every system clock cycle (125 ns). The SW_EVN flag of the STATUS register is raised when a switch turn-on event (SW input falling edge) is detected ([Section 11.1.28](#)). A GetStatus command releases the SW_EVN flag ([Section 11.2.20 on page 82](#)).

By default, a switch turn-on event causes a HardStop interrupt (SW_MODE bit of CONFIG register set to '0'). Otherwise (SW_MODE bit of CONFIG register set to '1'), switch input events do not cause interrupts and the switch status information is at the user's disposal ([Table 42 on page 67](#)).

The switch input can be used by GoUntil and ReleaseSW commands as described in [Section 11.2.10 on page 78](#) and [Section 11.2.11 on page 79](#).

If the SW input is not used, it should be connected to V_{DD} .

Figure 14. External switch connection

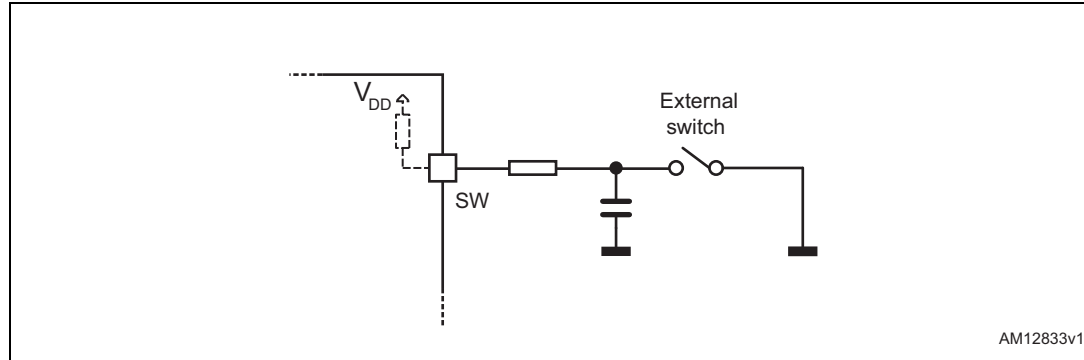

7.15 Integrated power MOSFETs

The typical characteristics of the 8 N-channel MOSFETs integrated into the system-in-package are listed in [Table 10](#).

Table 10. Integrated MOSFETs characteristics at $T_j = 25\text{ }^\circ\text{C}$

Symbol	Parameter	Typical value	Unit
$V_{GS(th)}$	Gate threshold voltage	3	V
Q_g	Total gate charge at $V_{gs} = 10\text{ V}$	25	nC
V_{SD}	Source-drain diode forward on voltage at $I_{SD} = 10\text{ A}$	0.8	V

7.16 Programmable slew rate

The powerSTEP01 integrates eight programmable gate drivers which allow the output slew rate to be fixed in a wide range of values.

The following parameters can be adjusted:

- Gate sink/source current (I_{GATE})
- controlled current time (t_{CC})
- Turn-off over-boost time (t_{OB}).

During the turn-on, the gate driver charges the gate forcing an I_{GATE} current for all the controlled current time period. At the end of the controlled current phase the gate of the integrated MOSFET should be completely charged.

During the turn-off the gate driver discharges the gate sinking an I_{GATE} current for all the controlled current time period. At the beginning of the turn-off an overboost phase can be added: in this case the gate driver sinks an I_{OB} current for the programmed t_{OB} period in order to rapidly reach the plateau region. At the end of the controlled current time the gate of the integrated MOSFET should be completely discharged.

The gate current can be set to one of following values: 4, 8, 16, 24, 32, 64 and 96 mA through the I_{GATE} parameter in the GATECFG1 register.

Controlled current time can be programmed within range from 125 ns to 3.75 μ s with a resolution 125 ns (TCC parameter in GATECFG1 register).

Turn-off overboost time can be set to one of following values: 0, 62.5, 125, 250 ns (TBOOST parameter in GATECFG1 register). The 62.5 ns value is only available when clock frequency is 16 MHz or 32 MHz; when clock frequency is 8 MHz it is changed to 125 ns and when a 24 MHz clock is used it is changed to 83.3 ns.

Table 11. Output slew rate

Slew rate ($V_S = 48 V$)	I_{gate}	t_{CC}	t_{DT}	t_{blank}	t_{boost}
980 V/ μ s	96 mA	375 ns	125 ns	500 ns	0 ns
790 V/ μ s	64 mA	500 ns	125 ns	375 ns	0 ns
520 V/ μ s	32 mA	875 ns	125 ns	250 ns	0 ns
400 V/ μ s	24 mA	1000 ns	125 ns	250 ns	0 ns
220 V/ μ s	16 mA	1600 ns	125 ns	250 ns	0 ns
114 V/ μ s	8 mA	3125 ns	125 ns	250 ns	0 ns

7.17 Deadtime and blanking time

During the bridge commutation, a deadtime is added in order to avoid cross conductions. The deadtime can be programmed within a range from 125 ns to 4 μ s with a resolution of 125 ns (TDT parameter in the GATECFG2 register) (see [Section 11.1.26 on page 64](#)).

At the end of each commutation the overcurrent and stall detection comparators are disabled (blanking) in order to avoid the respective systems detecting body diodes turn-off current peaks.

The duration of blanking time is programmable through the TBLANK parameter in the GATECFG2 register at one of the following values: 125, 250, 375, 500, 625, 750, 875, 1000 ns (see [Section 11.1.26](#)).

7.18 Integrated analog-to-digital converter

The powerSTEP01 integrates an N_{ADC} bit ramp-compare analog to digital converter with a reference voltage equal to V_{REG} . The analog to digital converter input is available through the ADCIN pin and the conversion result is available in the ADC_OUT register ([Section 11.1.20 on page 60](#)).

The ADC_OUT value can be used for motor supply voltage compensation or can be at the user's disposal.

7.19 Supply management and internal voltage regulators

The powerSTEP01 integrates two linear voltage regulators: the first one can be used to obtain gate driver supply starting from a higher voltage (e.g.: the motor supply one). Its output voltage can be set to 7.5 V or 15 V according to the VCCVAL bit value (CONFIG register). The second linear voltage regulator can be used to obtain the 3.3 V logic supply voltage.

The regulator is designed to supply the internal circuitry of the IC and should not be used to supply external components.

The input and output voltages of both regulators are connected to external pins and the regulators are totally independent: in this way a very flexible supply management can be performed using external components or external supply voltages (Figure 15).

Figure 15. Device supply pin management

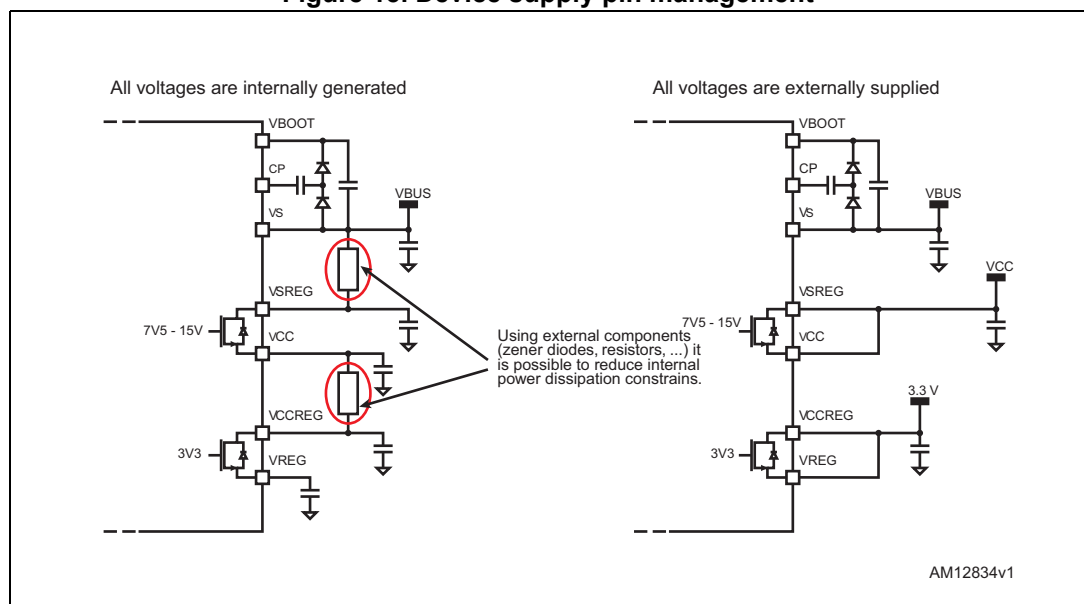

If V_{CC} is externally supplied, the VSREG and VCC pins must be shorted (V_{SREG} must be compliant with V_{CC} range).

If V_{REG} is externally supplied, the VCCREG and VREG pins must be shorted and equal to 3.3 V.

V_{SREG} must be always less than V_{BOOT} in order to avoid related ESD protection diode turn-on. The device can be protected from this event by adding an external low drop diode between the VSREG and VS pins, charge pump diodes should be low drop too.

V_{CCREG} must be always less than V_{CC} in order to avoid ESD protection diode turn-on. The device can be protected from this event by adding an external low drop diode between the VCCREG and VSREG pins.

Both regulators provide a short circuit protection limiting the load current within the respective maximum ratings.

7.20 BUSY/SYNC pin

This pin is an open-drain output which can be used as busy flag or synchronization signal according to the SYNC_EN bit value (STEP_MODE register) (see [Section 11.1.23 on page 61](#)).

7.21 FLAG pin

By default, an internal open-drain transistor pulls the $\overline{\text{FLAG}}$ pin to ground when at least one of the following conditions occurs:

- Power-up or standby/reset exit
- Stall detection on bridge A
- Stall detection on bridge B
- Overcurrent detection
- Thermal warning
- Thermal shutdown
- UVLO
- UVLO on ADC input
- Switch turn-on event
- Command error

It is possible to mask one or more alarm conditions by programming the ALARM_EN register (see [Table 32 on page 63](#)). If the corresponding bit of the ALARM_EN register is low, the alarm condition is masked and it does not cause a FLAG pin transition; all other actions imposed by alarm conditions are performed anyway. In case of daisy chain configuration, FLAG pins of different ICs can be or-wired to save host controller GPIOs.

8 Phase current control: voltage mode

When the voltage mode driving is selected (CM_VM bit in STEP_MODE register is set to 0), the powerSTEP01 controls the phase current applying a sinusoidal voltage to motor windings. Phase current amplitude is not directly controlled but depends on phase voltage amplitude, load torque, motor electrical characteristics and rotation speed. Sinewave amplitude is proportional to the motor supply voltage multiplied by a coefficient (K_{VAL}). K_{VAL} ranges from 0 to 100% and the sinewave amplitude can be obtained through the following formula:

Equation 1

$$V_{OUT} = V_S \cdot K_{VAL}$$

Different K_{VAL} values can be programmed for acceleration, deceleration and constant speed phases and when the motor is stopped (HOLD phase) through KVAL_ACC, KVAL_DEC, KVAL_RUN and KVAL_HOLD registers ([Section 11.1.10 on page 56](#)). K_{VAL} value is calculated according to the following formula:

Equation 2

$$K_{VAL} = [(K_{VAL_X} + BEMF_COMP) \times VSCOMP \times K_THERM] \times \text{microstep}$$

where K_{VAL_X} is the starting K_{VAL} value programmed for the present motion phase (KVAL_ACC, KVAL_DEC, KVAL_RUN or KVAL_HOLD), $BEMF_COMP$ is the BEMF compensation curve value, $VSCOMP$ and K_THERM are the motor supply voltage and winding resistance compensation factors and microstep is the current microstep value (fraction of target peak current).

The powerSTEP01 offers various methods to guarantee a stable current value, allowing the compensation of:

- Low speed distortion ([Section 8.3](#))
- Back electromotive force ([Section 8.4](#))
- Motor supply voltage variation ([Section 8.5](#))
- Winding resistance variation ([Section 8.6 on page 42](#))

8.1 PWM sinewave generators

The two voltage sinewaves applied to the stepper motor phases are generated by two PWM modulators.

The PWM frequency (f_{PWM}) is proportional to the oscillator frequency (f_{OSC}) and can be obtained through the following formula:

Equation 3

$$f_{\text{PWM}} = \frac{f_{\text{OSC}}}{512 \cdot N} \cdot m$$

'N' is the integer division factor and 'm' is the multiplication factor. 'N' and 'm' values can be programmed by F_PWM_INT and F_PWM_DEC parameters in the CONFIG register (see [Table 47 on page 68](#) and [Table 48 on page 69](#)).

Available PWM frequencies are listed in [Section 11.1.27 on page 66](#) from [Table 49 on page 69](#) to [Table 52 on page 70](#).

8.2 Sensorless stall detection

The powerSTEP01 is able to detect a motor stall caused by an excessive load torque. When the motor is driven using the voltage mode approach, a stall condition corresponds to an unexpected increase of the phase current. Imposing a current threshold slightly above the operative current, it is possible to detect the stall condition without speed or position sensors.

The powerSTEP01 measures the load current of each phase sensing the V_{DS} voltage of the low-side power MOSFETs. When any of the V_{DS} voltages rise over the programmed threshold, the STEP_LOSS_X flag in the STATUS register of the respective bridge (STEP_LOSS_A or STEP_LOSS_B) is forced low. The failure flag is kept low until the V_{DS} voltages fall below the programmed threshold and a GetStatus command is sent to the device ([Section 11.1.27](#) and [Section 11.2.20 on page 82](#)).

The stall detection threshold can be programmed in one of 32 available values ranging from 31.25 mV to 1 V with steps of 31.25 mV (see [Section 11.1.22 on page 61](#)).

Stall detection comparators are disabled, in order to avoid wrong voltage measurements, in the following cases:

- The respective half-bridge is in high impedance state (both MOSFETs forced off).
- The respective half-bridge is commutating.
- The respective half-bridge is commutated and the programmed blanking time has not yet elapsed.
- The respective low-side gate is turned off.

8.3 Low speed optimization

When the motor is driven at a very low speed using a small driving voltage, the resulting phase current can be distorted. As a consequence, the motor position is different from the ideal one (see [Figure 16](#)).

The device implements a low speed optimization in order to remove this effect.

Figure 16. Current distortion and compensation

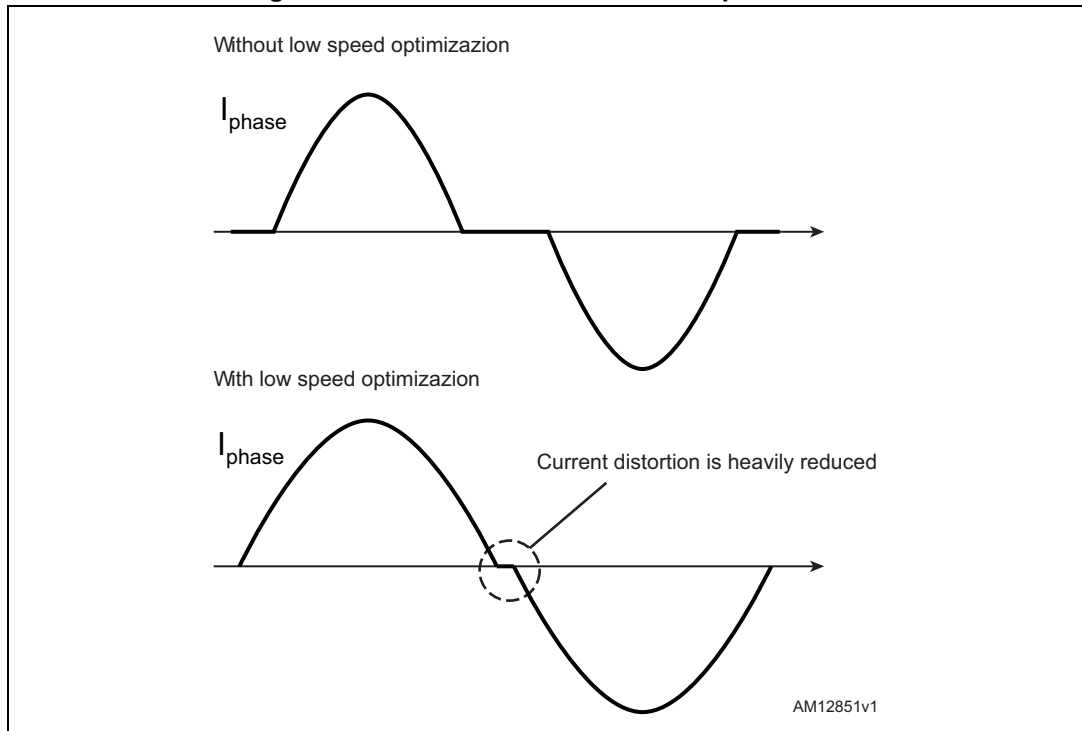

The optimization can be enabled setting high the LSPD_OPT bit in the MIN_SPEED register ([Section 11.1.8 on page 55](#)) and is active in a speed range from zero to MIN_SPEED. When low speed optimization is enabled, speed profile minimum speed is forced to zero.

8.4 BEMF compensation

Using the speed information, a compensation curve is added to the amplitude of the voltage waveform applied to the motor winding in order to compensate the BEMF variations during acceleration and deceleration (see [Figure 17](#)).

The compensation curve is approximated by a stacked line with a starting slope (ST_SLP) when speed is lower than a programmable threshold speed (INT_SPEED) and a fine slope (FN_SLP_ACC and FN_SLP_DEC) when speed is greater than the threshold speed (see sections [11.1.11 on page 56](#), [11.1.12 on page 56](#), [11.1.13 on page 57](#) and [11.1.14 on page 57](#)).

Figure 17. BEMF compensation curve

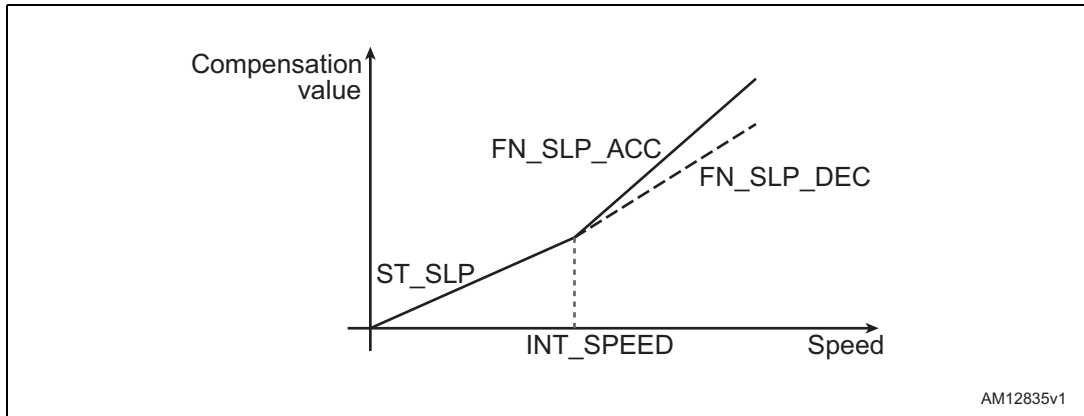

To obtain different current values during acceleration and deceleration phase, two different final slope values, and consequently two different compensation curves, can be programmed.

Acceleration compensation curve is applied when the motor runs. No BEMF compensation is applied when the motor is stopped.

8.5 Motor supply voltage compensation

The sinewave amplitude generated by the PWM modulators is directly proportional to the motor supply voltage (V_S). When the motor supply voltage is different from its nominal value, the motor phases are driven with an incorrect voltage. The powerSTEP01 can compensate motor supply voltage variations in order to avoid this effect.

The motor supply voltage should be connected to the integrated ADC input through a resistor divider in order to obtain $V_{REG}/2$ voltage at the ADCIN pin when V_S is at its nominal value (see Figure 18).

The ADC input is sampled at f_S frequency, which is equal to PWM frequency.

Figure 18. Motor supply voltage compensation circuit

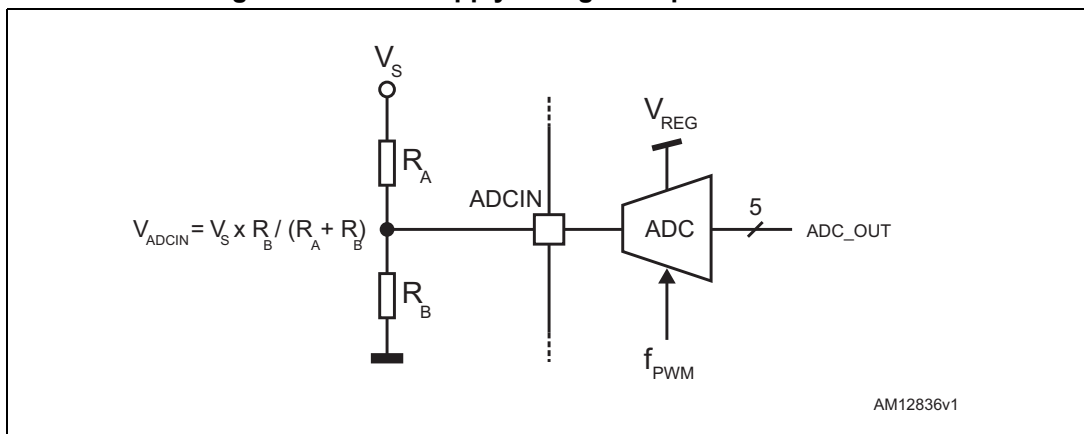

Motor supply voltage compensation can be enabled setting high the EN_VSCOMP bit of the CONFIG register (see [Table 46 on page 68](#)). If the EN_VSCOMP bit is low, the compensation is disabled and the internal analog to digital converter is at the user's disposal; the sampling rate is always equal to PWM frequency.

8.6 Winding resistance thermal drift compensation

The higher the winding resistance the greater the voltage to be applied in order to obtain the same phase current.

The powerSTEP01 integrates a register (K_THERM) which can be used to compensate phase resistance increment due to temperature rising.

The value in the K_THERM register ([Section 11.1.15 on page 57](#)) multiplies duty cycle value allowing the higher phase resistance value to be faced.

The compensation algorithm and the eventual motor temperature measurement should be implemented by microcontroller firmware.

9 Phase current control: current mode

When the current mode driving is selected (CM_VM bit in STEP_MODE register is set to 1), the powerSTEP01 performs a new current control technique, named predictive current control, allowing the device to obtain the target average phase current. This method is described in detail in [Section 9.1](#). Furthermore, the powerSTEP01 automatically selects the better decay mode in order to follow the current profile.

Current control algorithm parameters can be programmed by T_FAST, TON_MIN, TOFF_MIN and CONFIG registers (see [Section 11.1.11 on page 56](#), [11.1.12 on page 56](#), [11.1.19 on page 59](#) and [11.1.27 on page 66](#) for details).

Different current amplitude can be set for acceleration, deceleration and constant speed phases and when the motor is stopped through TVAL_ACC, TVAL_DEC, TVAL_RUN and TVAL_HOLD registers (see [Section 11.1.16 on page 58](#)). The output current amplitude can also be regulated by the ADCIN voltage value (see [Section 9.4](#)).

Each bridge is driven by an independent control system that shares with the other bridge the control parameters only.

9.1 Predictive current control

Unlike classical peak current control systems, that make the phase current decay when the target value is reached, this new method keeps the power bridge ON for an extra time after reaching the current threshold.

At each cycle the system measures the time required to reach the target current (t_{SENSE}). After that the power stage is kept in a “predictive” ON state (t_{PRED}) for a time equal to the mean value of t_{SENSE} in the last two control cycles (actual one and previous one), as shown in [Figure 19](#).

Figure 19. Predictive current control

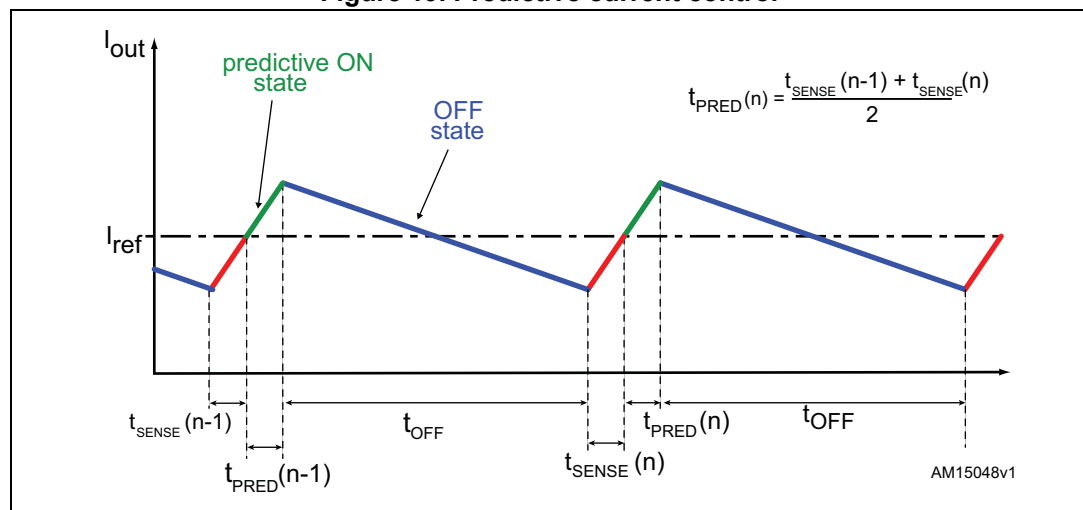

At the end of the predictive ON state the power stage is set in OFF state for a fixed time, as in a constant t_{OFF} current control. During the OFF state both slow and fast decay can be performed; the better decay combination is automatically selected by the powerSTEP01, as described in [Section 9.2](#).

As shown in [Figure 19](#), the system is able to center the triangular wave on the desired reference value, improving dramatically the accuracy of the current control system: in fact the average value of a triangular wave is exactly equal to the middle point of each of its segment and at steady-state the predictive current control tends to equalize the duration of the t_{SENSE} and the t_{PRED} time.

Furthermore, the t_{OFF} value is recalculated each time a new current value is requested (microstep change) in order to keep the PWM frequency as near as possible to the programmed one (TSW parameter in the CONFIG register).

The device can be forced to work using classic peak current control setting low the PRED_EN bit in the CONFIG register (default condition). In this case, after the sense phase (t_{SENSE}) the power stage is set in OFF state, as shown in [Figure 20](#).

Figure 20. Non-predictive current control

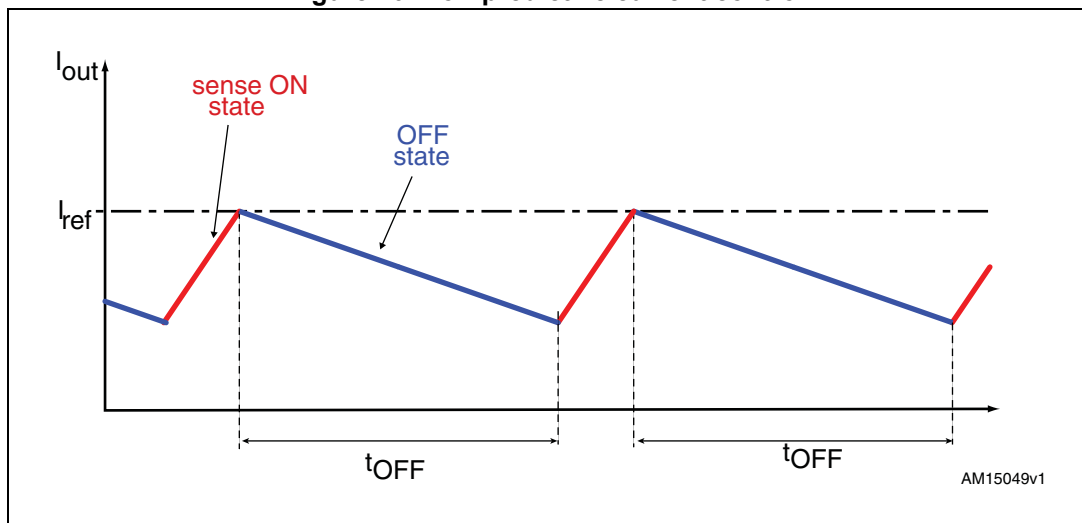

9.2 Auto-adjusted decay mode

During the current control, the device automatically selects the better decay mode in order to follow the current profile reducing the current ripple.

At reset, the off-time is performed turning on both the low-side MOS of the power stage and the current recirculates in the lower half of the bridge (slow decay).

If, during a PWM cycle, the target current threshold is reached in a time shorter than the TON_MIN value, a fast decay of TOFF_FAST/8 (T_FAST register) is immediately performed turning on the opposite MOS of both half-bridges and the current recirculates back to the supply bus.

After this time, the bridge returns to ON state: if the time needed to reach the target current value is still less than TON_MIN, a new fast decay is performed with a period twice the previous one. Otherwise, the normal control sequence is followed as described in [Section 9.1](#). The maximum fast decay duration is set by the TOFF_FAST value.

Figure 21. Adaptive decay - fast decay tuning

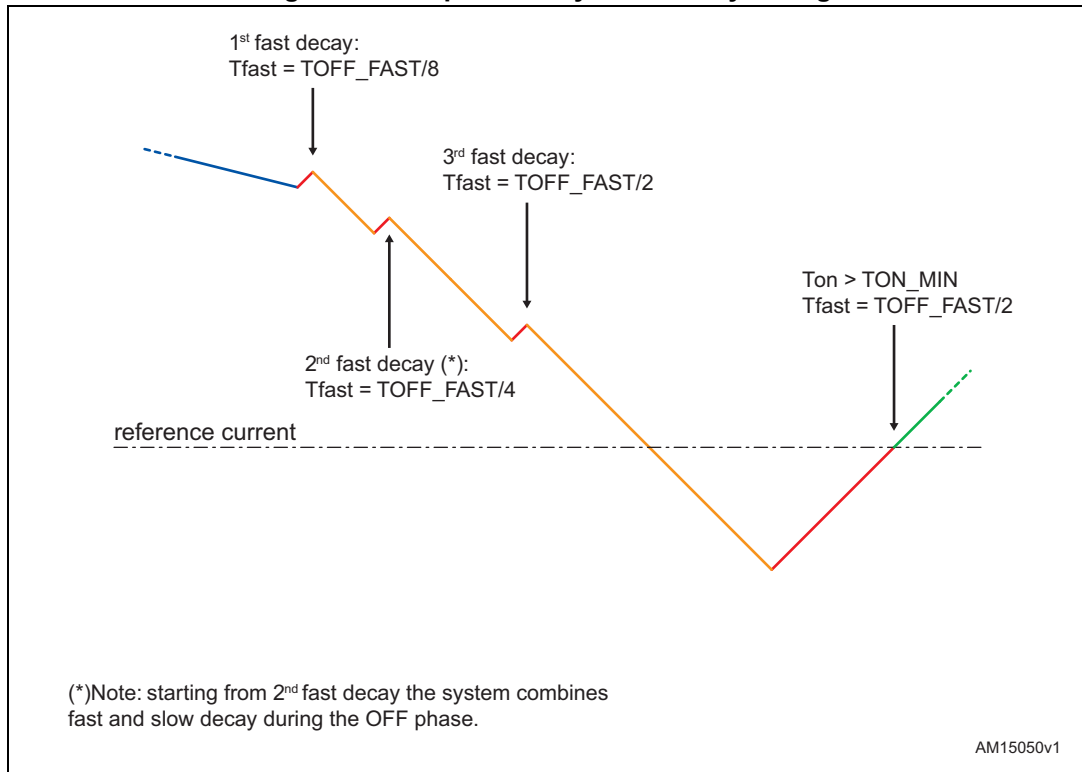

When two or more fast decays are performed with the present target current, the control system adds a fast decay at the end of every off-time keeping the OFF state duration constant (t_{OFF} is split into $t_{OFF, SLOW}$ and $t_{OFF, FAST}$). When the current threshold is increased by a microstep change (rising step), the system returns to normal decay mode (slow decay only) and the t_{FAST} value is halved.

Stopping the motor or reaching the current sinewave zero crossing causes the current control system to return to the reset state.

Figure 22. Adaptive decay - switch from normal to slow+ fast decay mode and vice versa

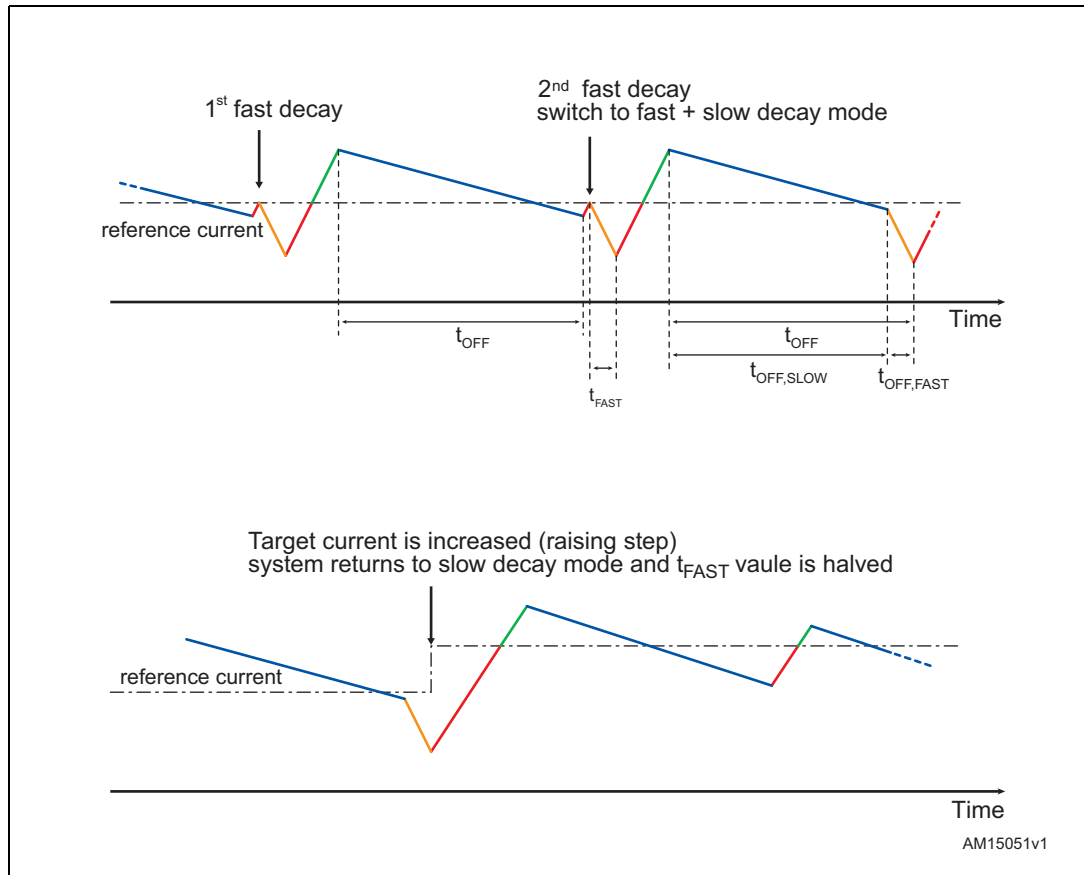

9.3 Auto-adjusted fast decay during the falling steps

When the target current is decreased by a microstep change (falling step), the device performs a fast decay in order to reach the new value as fast as possible. However, exceeding the fast duration could cause a strong ripple on the step change. The powerSTEP01 automatically adjusts these fast decays reducing the current ripple.

At reset the fast decay value (t_{FALL}) is set to $FALL_STEP/4$ (T_FAST register). The t_{FALL} value is doubled every time, within the same falling step, an extra fast decay is necessary to obtain an on-time greater than TON_MIN (see [Section 11.1.18 on page 59](#)). The maximum t_{FALL} value is equal to $FALL_STEP$.

At the next falling step, the system uses the last t_{FALL} value of the previous falling step.

Stopping the motor or reaching the current sinewave zero crossing causes the current control system to return to the reset state.

Figure 23. Fast decay tuning during the falling steps

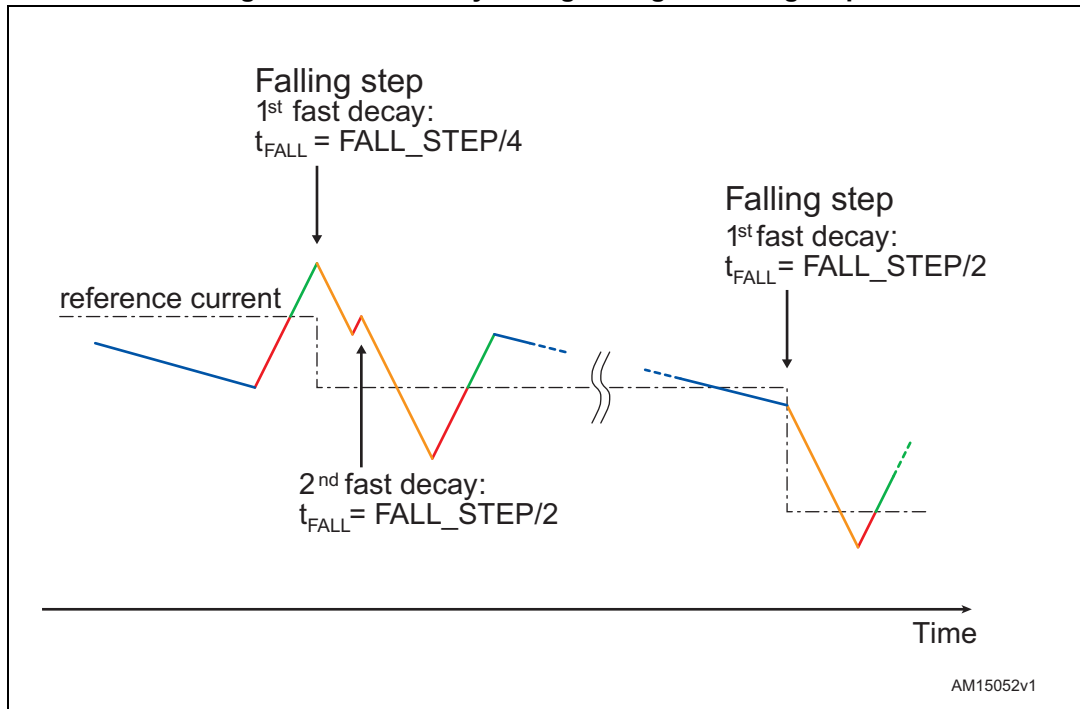

9.4 Torque regulation (setting the output current)

The phase currents are monitored through two shunt resistors (one for each power bridge) connected to the respective sense pin (see [Figure 24](#)). The integrated comparator compares the sense resistor voltage with the internal reference generated using the peak value, which is proportional to the output current amplitude, and the microstepping code. The comparison result is provided to the logic in order to implement the current control algorithm as described in previous sections.

The peak reference voltage can be regulated in two ways: writing TVAL_ACC, TVAL_DEC, TVAL_RUN and TVAL_HOLD registers or varying the ADCIN voltage value.

The EN_TQREG bit (CONFIG register) sets the torque regulation method. If this bit is high, ADC_OUT prevalue is used to regulate output current amplitude (see [Table 24 on page 60](#)). Otherwise the internal analog-to-digital converter is at the user's disposal and the output current amplitude is managed by TVAL_HOLD, TVAL_RUN, TVAL_ACC and TVAL_DEC registers (see [Table 18 on page 58](#)).

The voltage applied to the ADCIN pin is sampled at f_S frequency and converted in an NADC bit digital signal. The analog-to-digital conversion result is available in the ADC_OUT register.

Figure 24. Current sensing and reference voltage generation

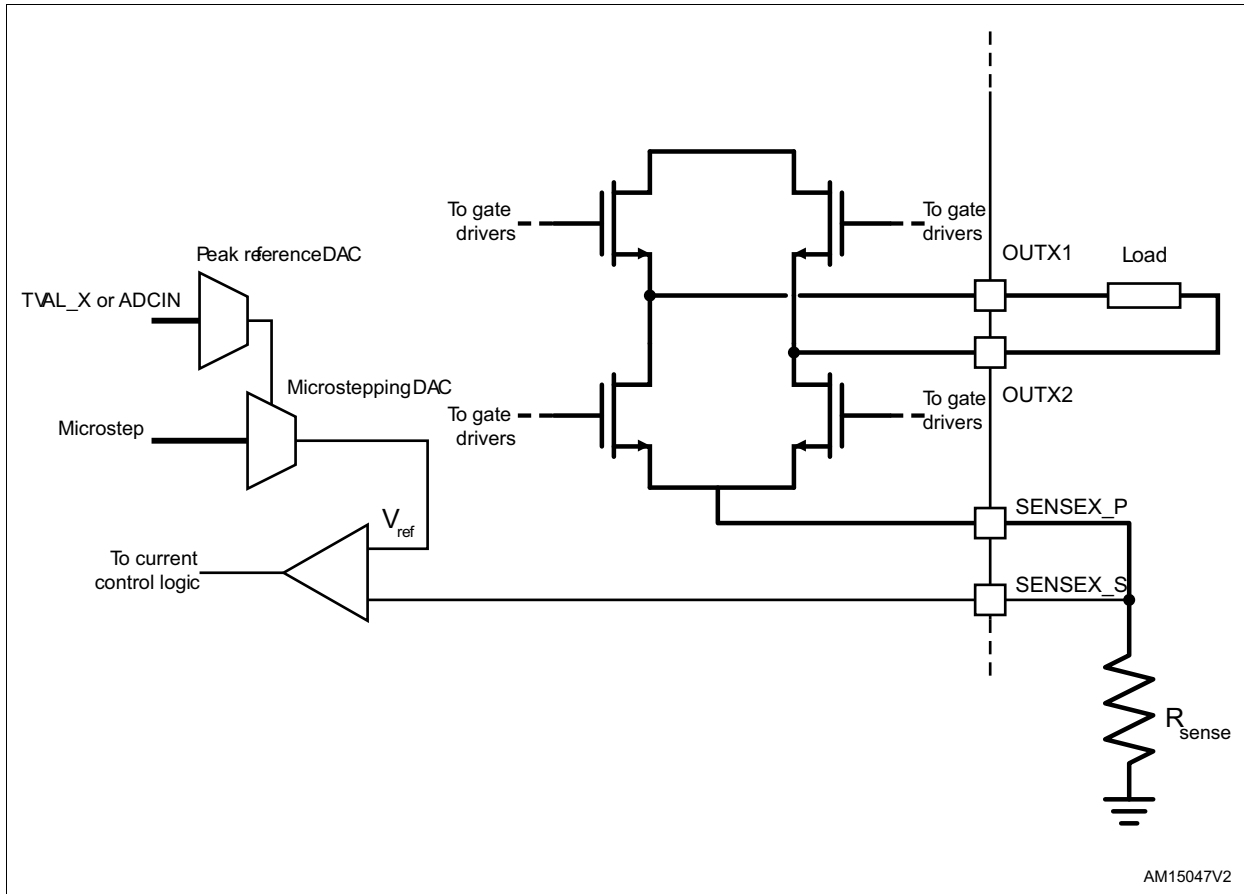

10 Serial interface

The integrated 8-bit serial peripheral interface (SPI) is used for a synchronous serial communication between the host microprocessor (always master) and the device (always slave).

The SPI uses chip select (\overline{CS}), serial clock (CK), serial data input (SDI) and serial data output (SDO) pins. When \overline{CS} is high the device is unselected and the SDO line is inactive (high impedance).

The communication starts when \overline{CS} is forced low. The CK line is used for synchronization of data communication.

All commands and data bytes are shifted into the device through the SDI input, most significant bit first. The SDI is sampled on the rising edges of the CK.

All output data bytes are shifted out of the device through the SDO output, most significant bit first. The SDO is latched on the falling edges of the CK. When a return value from the device is not available, an all zero byte is sent.

After each byte transmission the \overline{CS} input must be raised and be kept high for at least t_{disCS} in order to allow the device to decode the received command and put the return value into the shift register.

All timing requirements are shown in [Figure 25](#) (see [Section 3 on page 12](#) for values).

Multiple devices can be connected in daisy chain configuration, as shown in [Figure 26](#).

Figure 25. SPI timings diagram

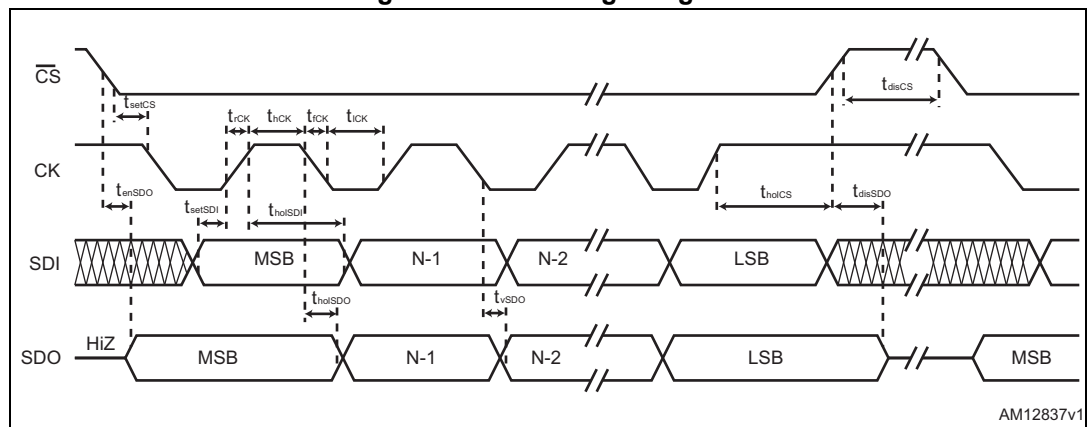
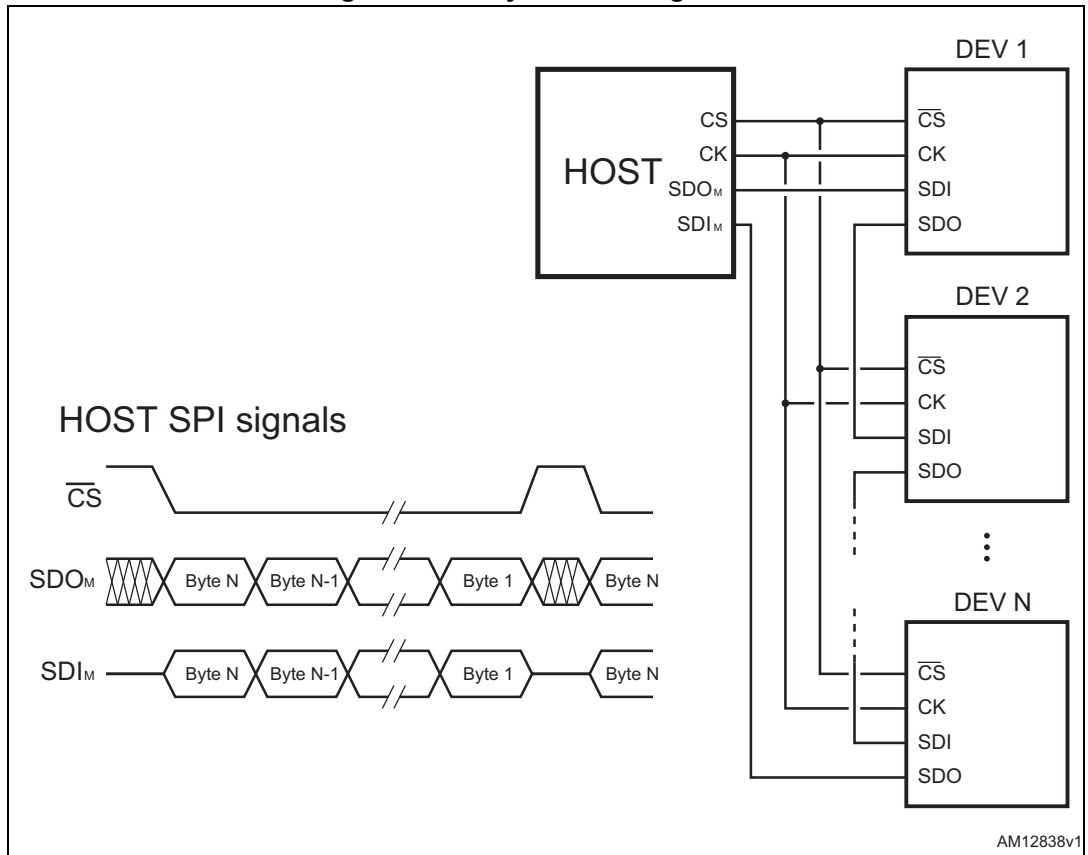

Figure 26. Daisy chain configuration



11 Programming manual

11.1 Register and flag description

Following a map of the user available registers (detailed description in respective paragraphs):

Table 12. Register map

Address [Hex]	Register name	Register function	Length [bit]	Reset [Hex]	Reset value	Remarks (1)
General configuration						
h01	ABS_POS	Current position	22	000000	0	R, WS
h02	EL_POS	Electrical position	9	000	0	R, WS
h03	MARK	Mark position	22	000000	0	R, WR
h04	SPEED	Current speed	20	00000	0 step/tick (0 step/s)	R
h05	ACC	Acceleration	12	08A	125.5e-12 step/tick ² (2008 step/s ²)	R, WS
h06	DEC	Deceleration	12	08A	125.5e-12 step/tick ² (2008 step/s ²)	R, WS
h07	MAX_SPEED	Maximum speed	10	041	248e-6 step/tick (991.8 step/s)	R, WR
h08	MIN_SPEED	Minimum speed	12	000	0 step/tick (0 step/s)	R, WS
h12	ADC_OUT	ADC output	5	XX(2)	0	R
h13	OCD_TH	OCD threshold	5	8	TBD	R, WR
h15	FS_SPD	Full-step speed	11	027	150.7e-6 step/tick (602.7 step/s)	R, WR
h16	STEP_MODE	Step mode	8	7	BUSY/SYNC output used as BUSY, 128 microsteps, voltage mode	R, WH
h17	ALARM_EN	Alarm enables	8	FF	All alarms enabled	R, WS
h18	GATECFG1	Gate driver configuration	11	TBD	I _{gate} = 4 mA, t _{CC} = 125 ns, no boost	R, WH
h19	GATECFG2	Gate driver configuration	8	TBD	t _{BLANK} = 125 ns, t _{DT} = 125 ns	R, WH
h1B	STATUS	Status	16	XXXX(2)	High impedance state, motor stopped, reverse direction, all fault flags released UVLO/reset flag set	R
h1A	CONFIG	IC configuration	16	TBD	Internal 16 MHz oscillator (OSCOUT at 2 MHz), SW event causes HardStop, overcurrent shutdown, V _{CC} = 7.5 V, UVLO threshold low	R, WH

Table 12. Register map (continued)

Address [Hex]	Register name	Register function	Length [bit]	Reset [Hex]	Reset value	Remarks (1)
Voltage mode configuration						
h09	KVAL_HOLD	Holding K_{VAL}	8	29	$0.16 \cdot V_S$	R, WR
h0A	KVAL_RUN	Constant speed K_{VAL}	8	29	$0.16 \cdot V_S$	R, WR
h0B	KVAL_ACC	Acceleration starting K_{VAL}	8	29	$0.16 \cdot V_S$	R, WR
h0C	KVAL_DEC	Deceleration starting K_{VAL}	8	29	$0.16 \cdot V_S$	R, WR
h0D	INT_SPEED	Intersect speed	14	0408	$15.4e-6$ step/tick (61.5 step/s)	R, WH
h0E	ST_SLP	Start slope	8	19	250.038% s/step	R, WH
h0F	FN_SLP_ACC	Acceleration final slope	8	29	0.063% s/step	R, WH
h10	FN_SLP_DEC	Deceleration final slope	8	29	0.063% s/step	R, WH
h11	K_THERM	Thermal compensation factor	4	0	1.0	R, WR
h14	STALL_TH	STALL threshold	5	10	TBD	R, WR
h1A	CONFIG	IC configuration	16	TBD	Motor supply voltage compensation disabled, $f_{PWM} = f_{OSC} / 1024$	R, WH
Current mode configuration						
h09	TVAL_HOLD	Holding reference voltage	8	29	328 mV	R, WR
h0A	TVAL_RUN	Constant speed reference voltage	8	29	328 mV	R, WR
h0B	TVAL_ACC	Acceleration reference voltage	8	29	328 mV	R, WR
h0C	TVAL_DEC	Deceleration reference voltage	8	29	328 mV	R, WR
h0E	T_FAST	Fast decay setting	8	19	1 μ s / 5 μ s	R, WH
h0F	TON_MIN	Minimum on-time	8	29	20.5 μ s	R, WH
h10	TOFF_MIN	Minimum off-time	8	29	20.5 μ s	R, WH
h1A	CONFIG	IC configuration	16	TBD	Predictive current control disabled, $t_{SW} = 44 \mu$ s	R, WH

1. R: readable, WH: writable when the outputs are in high impedance only, WS: writable when the motor is stopped only, WR: always writable.
2. According to startup conditions.

11.1.1 ABS_POS

The ABS_POS register contains the current motor absolute position in agreement with the selected step mode; the stored value unit is equal to the selected step mode (full, half, quarter, etc.). The value is in 2's complement format and it ranges from -2^{21} to $+2^{21}-1$.

At power-on the register is initialized to "0" (HOME position).

Any attempt to write the register when the motor is running causes the command to be ignored and the CMD_ERROR flag to rise ([Section 11.1.28 on page 71](#)).

11.1.2 EL_POS

The EL_POS register contains the current electrical position of the motor. The two MSbits indicate the current step and the other bits indicate the current microstep (expressed in step/128) within the step.

Table 13. EL_POS register

Bit 8	Bit 7	Bit 6	Bit 5	Bit 4	Bit 3	Bit 2	Bit 1	Bit 0
STEP		MICROSTEP						

When the EL_POS register is written by the user the new electrical position is instantly imposed. When the EL_POS register is written, its value must be masked in order to match with the step mode selected in the STEP_MODE register in order to avoid a wrong microstep value generation ([Section 11.1.23 on page 61](#)); otherwise the resulting microstep sequence is incorrect. When the device operates in current mode, the bit number 0, 1 and 2 of the EL_POS register are meaningless because the maximum microstepping resolution is $1/16^{\text{th}}$ of step.

Any attempt to write the register when the motor is running causes the command to be ignored and the CMD_ERROR flag to rise ([Section 11.1.28](#)).

11.1.3 MARK

The MARK register contains an absolute position called MARK, according to the selected step mode; the stored value unit is equal to the selected step mode (full, half, quarter, etc.). It is in 2's complement format and it ranges from -2^{21} to $+2^{21}-1$.

11.1.4 SPEED

The SPEED register contains the current motor speed, expressed in step/tick (format unsigned fixed point 0.28).

In order to convert the SPEED value in step/s the following formula can be used:

Equation 4

$$[\text{step/s}] = \frac{\text{SPEED} \cdot 2^{-28}}{\text{tick}}$$

where *SPEED* is the integer number stored in the register and tick is 250 ns.

The available range is from 0 to 15625 step/s with a resolution of 0.015 step/s.

Note: The range effectively available to the user is limited by the MAX_SPEED parameter.

Any attempt to write the register causes the command to be ignored and the CMD_ERROR flag to rise ([Section 11.1.28 on page 71](#)).

11.1.5 ACC

The ACC register contains the speed profile acceleration expressed in step/tick² (format unsigned fixed point 0.40).

In order to convert the ACC value in step/s² the following formula can be used:

Equation 5

$$[\text{step/s}^2] = \frac{\text{ACC} \cdot 2^{-40}}{\text{tick}^2}$$

where ACC is the integer number stored in the register and tick is 250 ns.

The available range is from 14.55 to 59590 step/s² with a resolution of 14.55 step/s².

The 0xFFF value of the register is reserved and it should never be used.

Any attempt to write to the register when the motor is running causes the command to be ignored and the CMD_ERROR flag to rise ([Section 11.1.28](#)).

11.1.6 DEC

The DEC register contains the speed profile deceleration expressed in step/tick² (format unsigned fixed point 0.40).

In order to convert the DEC value in step/s² the following formula can be used:

Equation 6

$$[\text{step/s}^2] = \frac{\text{DEC} \cdot 2^{-40}}{\text{tick}^2}$$

where DEC is the integer number stored in the register and tick is 250 ns.

The available range is from 14.55 to 59590 step/s² with a resolution of 14.55 step/s².

Any attempt to write the register when the motor is running causes the command to be ignored and the CMD_ERROR flag to rise ([Section 11.1.28](#)).

11.1.7 MAX_SPEED

The MAX_SPEED register contains the speed profile maximum speed expressed in step/tick (format unsigned fixed point 0.18).

In order to convert it in step/s, the following formula can be used:

Equation 7

$$[\text{step/s}] = \frac{\text{MAX_SPEED} \cdot 2^{-18}}{\text{tick}}$$

where MAX_SPEED is the integer number stored in the register and tick is 250 ns.

The available range is from 15.25 to 15610 step/s with a resolution of 15.25 step/s.

11.1.8 MIN_SPEED

The MIN_SPEED register contains the following parameters:

Table 14. MIN_SPEED register

Bit 12	Bit 11	Bit 10	Bit 9	Bit 8	Bit 7	Bit 6	Bit 5	Bit 4	Bit 3	Bit 2	Bit 1	Bit 0
LSPD_OPT	MIN_SPEED											

The MIN_SPEED parameter contains the speed profile minimum speed. Its value is expressed in step/tick and to convert it in step/s the following formula can be used:

Equation 8

$$[\text{step/s}] = \frac{\text{MIN_SPEED} \cdot 2^{-24}}{\text{tick}}$$

where *MIN_SPEED* is the integer number stored in the register and tick is the ramp 250 ns.

The available range is from 0 to 976.3 step/s with a resolution of 0.238 step/s.

When the LSPD_OPT bit is set high, low speed optimization feature is enabled (voltage mode driving only) and the MIN_SPEED value indicates the speed threshold below which the compensation works. In this case the minimum speed of the speed profile is set to zero.

Any attempt to write the register when the motor is running causes the CMD_ERROR flag to rise.

11.1.9 FS_SPD

The FS_SPD register contains the following parameters:

Table 15. FS_SPD register

Bit 10	Bit 9	Bit 8	Bit 7	Bit 6	Bit 5	Bit 4	Bit 3	Bit 2	Bit 1	Bit 0
BOOST_MODE	FS_SPD									

The FS_SPD threshold speed value over which the step mode is automatically switched to full-step two-phase on. Its value is expressed in step/tick (format unsigned fixed point 0.18) and to convert it in step/s the following formula can be used:

Equation 9

$$[\text{step/s}] = \frac{(\text{FS_SPD} + 0.5) \cdot 2^{-18}}{\text{tick}}$$

If FS_SPD value is set to hFF (max.) the system always works in Microstepping mode (SPEED must go over the threshold to switch to Full-step mode). Setting FS_SPD to zero does not have the same effect as setting the step mode to full-step two-phase on: the zero FS_SPD value is equivalent to a speed threshold of about 7.63 step/s.

The available range is from 7.63 to 15625 step/s with a resolution of 15.25 step/s.

The BOOST_MODE bit sets the amplitude of the voltage squarewave during the full-step operation (see [Section on page 24](#)).

11.1.10 KVAL_HOLD, KVAL_RUN, KVAL_ACC and KVAL_DEC

These registers are specific for voltage mode driving (see [Section 8 on page 38](#)).

The KVAL_HOLD register contains the K_{VAL} value that is assigned to the PWM modulators when the motor is stopped (compensations excluded).

The KVAL_RUN register contains the K_{VAL} value that is assigned to the PWM modulators when the motor is running at constant speed (compensations excluded).

The KVAL_ACC register contains the starting K_{VAL} value that can be assigned to the PWM modulators during acceleration (compensations excluded).

The KVAL_DEC register contains the starting K_{VAL} value that can be assigned to the PWM modulators during deceleration (compensations excluded).

The available range is from 0 to $0.996 \times V_S$ with a resolution of $0.004 \times V_S$, as shown in [Table 16](#).

Table 16. Voltage amplitude regulation registers

KVAL_X [7...0]								Output voltage
0	0	0	0	0	0	0	0	0
0	0	0	0	0	0	0	1	$V_S \times (1/256)$
⋮	⋮	⋮	⋮	⋮	⋮	⋮	⋮	⋮
1	1	1	1	1	1	1	0	$V_S \times (254/256)$
1	1	1	1	1	1	1	1	$V_S \times (255/256)$

11.1.11 INT_SPEED

This register is specific for voltage mode driving (see [Section 8](#)).

The INT_SPEED register contains the speed value at which the BEMF compensation curve changes slope ([Section 8.4 on page 40](#) for details). Its value is expressed in step/tick and to convert it in [step/s] the following formula can be used:

Equation 10

$$[\text{step/s}] = \frac{\text{INT_SPEED} \cdot 2^{-18}}{\text{tick}}$$

where *INT_SPEED* is the integer number stored in the register and tick is 250 ns.

The available range is from 0 to 976.5 step/s with a resolution of 0.0596 step/s.

Any attempt to write the register when the motor is running causes the command to be ignored and the CMD_ERROR flag to rise ([Section 11.1.28 on page 71](#)).

11.1.12 ST_SLP

This register is specific for voltage mode driving (see [Section 8](#)).

The ST_SLP register contains the BEMF compensation curve slope that is used when the speed is lower than the intersect speed ([Section 8.4](#)). Its value is expressed in s/step and the available range is from 0 to 0.004 with a resolution of 0.000015.

When ST_SLP, FN_SLP_ACC and FN_SLP_DEC parameters are set to zero, no BEMF compensation is performed.

Any attempt to write the register when the motor is running causes the command to be ignored and the CMD_ERROR flag to rise ([Section 11.1.28 on page 71](#)).

11.1.13 FN_SLP_ACC

This register is specific for voltage mode driving (see [Section 8 on page 38](#)).

The FN_SLP_ACC register contains the BEMF compensation curve slope that is used when the speed is greater than the intersect speed during acceleration ([Section 8.4 on page 40](#) for details). Its value is expressed in s/step and the available range is from 0 to 0.004 with a resolution of 0.000015.

When ST_SLP, FN_SLP_ACC and FN_SLP_DEC parameters are set to zero, no BEMF compensation is performed.

Any attempt to write the register when the motor is running causes the command to be ignored and the CMD_ERROR flag to rise ([Section 11.1.28](#)).

11.1.14 FN_SLP_DEC

This register is specific for voltage mode driving (see [Section 8](#)).

The FN_SLP_DEC register contains the BEMF compensation curve slope that is used when the speed is greater than the intersect speed during deceleration ([Section 8.4](#) for details). Its value is expressed in s/step and the available range is from 0 to 0.004 with a resolution of 0.000015.

When ST_SLP, FN_SLP_ACC and FN_SLP_DEC parameters are set to zero, no BEMF compensation is performed.

Any attempt to write the register when the motor is running causes the command to be ignored and the CMD_ERROR flag to rise ([Section 11.1.28](#)).

11.1.15 K_THERM

This register is specific for voltage mode driving (see [Section 8](#)).

The K_THERM register contains the value used by the winding resistance thermal drift compensation system ([Section 8.6 on page 42](#)).

The available range is from 1 to 1.46875 with a resolution of 0.03125, as shown in [Table 17](#).

Table 17. Winding resistance thermal drift compensation coefficient

K_THERM [3 ... 0]				Compensation coefficient
0	0	0	0	1
0	0	0	1	1.03125
⋮	⋮	⋮	⋮	⋮
1	1	1	0	1.4375
1	1	1	1	1.46875

11.1.16 TVAL_HOLD, TVAL_RUN, TVAL_ACC and TVAL_DEC

These registers are specific for current mode driving (see [Section 9 on page 43](#)).

The TVAL_HOLD register contains the reference voltage that is assigned to the torque regulation DAC when the motor is stopped.

The TVAL_RUN register contains the reference voltage that is assigned to the torque regulation DAC when the motor is running at constant speed.

The TVAL_ACC register contains the reference voltage that is assigned to the torque regulation DAC during acceleration.

The TVAL_DEC register contains the reference voltage that is assigned to the torque regulation DAC during deceleration.

The available range is from 7.8 mV to 1 V with a resolution of 7.8 mV, as shown in [Table 16](#).

Table 18. Torque regulation by TVAL_HOLD, TVAL_ACC, TVAL_DEC and TVAL_RUN registers

TVAL_X [6...0]							Peak reference voltage
0	0	0	0	0	0	0	7.8 mV
0	0	0	0	0	0	1	15.6 mV
⋮	⋮	⋮	⋮	⋮	⋮	⋮	⋮
1	1	1	1	1	1	0	992.2 mV
1	1	1	1	1	1	1	1 V

11.1.17 T_FAST

This register is specific for current mode driving (see [Section 9](#)).

The T_FAST register contains the maximum fast decay time (TOFF_FAST) and the maximum fall step time (FALL_STEP) used by the current control system ([Section 9.2 on page 44](#) and [Section 9.3 on page 46](#) for details):

Table 19. T_FAST register

Bit 7	Bit 6	Bit 5	Bit 4	Bit 3	Bit 2	Bit 1	Bit 0
TOFF_FAST				FAST_STEP			

The available range for both parameters is from 2 μs to 32 μs.

Table 20. Maximum fast decay times

TOFF_FAST [3 ... 0] FAST_STEP [3 ... 0]				Fast decay time
0	0	0	0	2 μ s
0	0	0	1	4 μ s
⋮	⋮	⋮	⋮	⋮
1	1	1	0	28 μ s
1	1	1	1	32 μ s

Any attempt to write to the register when the motor is running causes the command to be ignored and CMD_ERROR to rise ([Section 11.1.28 on page 71](#)).

11.1.18 TON_MIN

This register is specific for current mode driving (see [Section 9 on page 43](#)).

This parameter is used by the current control system when current mode operation is selected.

The TON_MIN register contains the minimum on-time value used by the current control system (see [Section 9.2 on page 44](#)).

The available range for both parameters is from 0.5 μ s to 64 μ s.

Table 21. Minimum on-time

TON MIN [6 ... 0]							Time
0	0	0	0	0	0	0	0.5 μ s
0	0	0	0	0	0	1	1 μ s
⋮	⋮	⋮	⋮	⋮	⋮	⋮	⋮
1	1	1	1	1	1	0	63.5 μ s
1	1	1	1	1	1	1	64 μ s

Any attempt to write to the register when the motor is running causes the command to be ignored and the CMD_ERROR to rise (see [Section 11.1.28](#)).

11.1.19 TOFF_MIN

This register is specific for current mode driving (see [Section 9](#)).

This parameter is used by the current control system when current mode operation is selected.

The TOFF_MIN register contains the minimum off-time value used by the current control system (see [Section 9.1 on page 43](#) for details).

The available range for both parameters is from 0.5 μ s to 64 μ s.

Table 22. Minimum off-time

TOFF MIN [6 ... 0]							Time
0	0	0	0	0	0	0	0.5 μ s
0	0	0	0	0	0	1	1 μ s
⋮	⋮	⋮	⋮	⋮	⋮	⋮	⋮
1	1	1	1	1	1	0	63.5 μ s
1	1	1	1	1	1	1	64 μ s

Any attempt to write to the register when the motor is running causes the command to be ignored and CMD_ERROR to rise (see [Section 11.1.28 on page 71](#)).

11.1.20 ADC_OUT

The ADC_OUT register contains the result of the analog to digital conversion of the ADCIN pin voltage.

Any attempt to write to the register causes the command to be ignored and the CMD_ERROR to rise.

Table 23. ADC_OUT value and motor supply voltage compensation feature

V_S	V_{ADCIN}/V_{REG}	ADC_OUT [4 ... 0]					Compensation coefficient
Greater than $V_{S,nom} + 50\%$	$> 24/32$	1	1	X	X	X	0.65625
$V_{S,nom} + 50\%$	$24/32$	1	1	0	0	0	0.65625
⋮	⋮	⋮	⋮	⋮	⋮	⋮	⋮
$V_{S,nom}$	$16/32$	1	0	0	0	0	1
⋮	⋮	⋮	⋮	⋮	⋮	⋮	⋮
$V_{S,nom} - 50\%$	$8/32$	0	1	0	0	0	1.96875
Lesser than $V_{S,nom} - 50\%$	$< 8/32$	0	0	X	X	X	1.96875

Table 24. ADC_OUT value and torque regulation feature

V_{ADCIN}/V_{REG}	ADC_OUT [4 ... 0]					Reference voltage
0	0	0	0	0	0	31.25 mV
1/32	0	0	0	0	1	62.5 mV
⋮	⋮	⋮	⋮	⋮	⋮	⋮
30/32	1	1	1	1	0	968.8 mV
31/32	1	1	1	1	1	1000 mV

11.1.21 OCD_TH

The OCD_TH register contains the overcurrent threshold value ([Section 7.9 on page 30](#) for details). The available range is from 31.25 mV to 1 V, steps of 31.25 mV, as shown in [Table 25](#).

Table 25. Overcurrent detection threshold

OCD_TH [4 ... 0]					Overcurrent detection threshold
0	0	0	0	0	31.25 mV
0	0	0	0	1	62.5 mV
...
1	1	1	1	0	968.75 mV
1	1	1	1	1	1 V

11.1.22 STALL_TH

This register is specific for voltage mode driving (see [Section 8 on page 38](#)).

The STALL_TH register contains the stall detection threshold value. The available range is from 31.25 mV to 1 V with a resolution of 31.25 mV.

Table 26. Stall detection threshold

STALL_th [4 ... 0]					Stall detection threshold
0	0	0	0	0	31.25 mV
0	0	0	0	1	62.5 mV
...
1	1	1	1	0	968.75 mV
1	1	1	1	1	1 V

11.1.23 STEP_MODE

The STEP_MODE register has the following structure:

Table 27. STEP_MODE register

Bit 7	Bit 6	Bit 5	Bit 4	Bit 3	Bit 2	Bit 1	Bit 0
SYNC_EN	SYNC_SEL			CM_VM	STEP_SEL		

The CM_VM bit sets the current control method between voltage and current mode:

Table 28. Control mode selection

CM_VM	Control mode
0	Voltage mode
1	Advanced current control (current mode)

STEP_SEL selects one of eight possible stepping modes:

Table 29. Step mode selection

STEP_SEL[2 ... 0]			Step mode (CM_VM = 0)	Step mode (CM_VM = 1)
0	0	0	Full-step	Full-step
0	0	1	Half-step	Half-step
0	1	0	1/4 microstep	1/4 microstep
0	1	1	1/8 microstep	1/8 microstep
1	0	0	1/16 microstep	1/16 microstep
1	0	1	1/32 microstep	1/16 microstep
1	1	0	1/64 microstep	1/16 microstep
1	1	1	1/128 microstep	1/16 microstep

Every time the step mode changes, the electrical position (i.e.: the point of microstepping sinewave that is generated) resets at the first microstep.

It is important to note that every time STEP_SEL changes, the value in ABS_POS register loses meaning and then it should be reset.

When sync clock is disabled, BUSY/SYNC output is used as BUSY (command state machine busy signaling), otherwise BUSY/SYNC output provides a clock signal according to SYNC_SEL parameter.

Table 30. Sync clock enable

SYNC_EN	Sync clock
0	Disabled
1	Enabled

Table 31. Sync clock selection

SYNC_SEL[2 ... 0]			Step information (CM_VM = 0)	Step information (CM_VM = 1)
0	0	0	Full-step	Full-step
0	0	1	Half-step	Half-step
0	1	0	1/4 microstep	1/4 microstep
0	1	1	1/8 microstep	1/8 microstep
1	0	0	1/16 microstep	1/16 microstep
1	0	1	1/32 microstep	Always low
1	1	0	1/64 microstep	Always low
1	1	1	1/128 microstep	Always low

Any attempt to write to the register, when the motor is running, causes the command to be ignored and the CMD_ERROR to rise (see [Section 11.1.28 on page 71](#)).

11.1.24 ALARM_EN

The `ALARM_EN` register allows the selection of which alarm signals are used to generate the `FLAG` output. If the respective bit of the `ALARM_EN` register is set high, the alarm condition forces the `FLAG` pin output down.

Table 32. ALARM_EN register

ALARM_EN bit	Alarm condition
0 (LSB)	Overcurrent
1	Thermal shutdown
2	Thermal warning
3	UVLO
4	ADC UVLO
5	Stall detection (voltage mode only)
6	Switch turn-on event
7 (MSB)	Command error

11.1.25 GATECFG1

The `GATECFG1` register has the following structure:

Table 33. GATECFG1 register

Bit 15	Bit 14	Bit 13	Bit 12	Bit 11	Bit 10	Bit 9	Bit 8
				WD_EN	TBOOST		
Bit 7	Bit 6	Bit 5	Bit 4	Bit 3	Bit 2	Bit 1	Bit 0
IGATE				TCC			

The `IGATE` parameter selects the sink/source current used by gate driving circuitry to charge/discharge the respective gate during commutations. Seven possible values ranging from 4 mA to 96 mA are available, as shown in [Table 34](#).

Table 34. IGATE parameter

IGATE [2 ... 0]			Gate current [mA]
0	0	0	4
0	0	1	4
0	1	0	8
0	1	1	16
1	0	0	24
1	0	1	32
1	1	0	64
1	1	1	96

The TCC parameter defines the duration of constant current phase during gate turn-on and turn-off sequences ([Section 7.16 on page 34](#)).

Table 35. TCC parameter

TCC [4 ... 0]					Constant current time [ns]
0	0	0	0	0	125
0	0	0	0	1	250
↓	↓	↓	↓	↓	↓
1	1	1	0	0	3625
1	1	1	0	1	3750
1	1	1	1	0	3750
1	1	1	1	1	3750

The TBOOST parameter defines the duration of the overboost phase during gate turn-off ([Section 7.16](#)).

Table 36. TBOOST parameter

TBOOST [2 ... 0]			Turn-off boost time [ns]
0	0	0	0
0	0	1	62.5 ⁽¹⁾ / 83.3 ⁽²⁾ / 125 ⁽³⁾
0	1	0	125
0	1	1	250
1	0	0	375
1	0	1	500
1	1	0	750
1	1	1	1000

1. Clock frequency equal to 16 MHz or 32 MHz.
2. Clock frequency equal to 24 MHz.
3. Clock frequency equal to 8 MHz.

The WD_EN bit enables the clock source monitoring ([Section 7.8.2 on page 29](#)).

11.1.26 GATECFG2

The GATECFG2 register has the following structure:

Table 37. GATECFG2 register (voltage mode)

Bit 7	Bit 6	Bit 5	Bit 4	Bit 3	Bit 2	Bit 1	Bit 0
TBLANK			TDT				

The TDT parameter defines the deadtime duration between the gate turn-off and the opposite gate turn-on sequences ([Section 7.17 on page 35](#)).

Table 38. TDT parameter

TDT [4 ... 0]					Deadtime [ns]
0	0	0	0	0	125
0	0	0	0	1	250
↓	↓	↓	↓	↓	↓
1	1	1	1	0	3875
1	1	1	1	1	4000

The TBLANK parameter defines the duration of the blanking of the current sensing comparators (stall detection and overcurrent) after each commutation ([Section 7.17](#)).

Table 39. TBLANK parameter

TBLANK [2 ... 0]			Blanking time [ns]
0	0	0	125
0	0	1	250
↓	↓	↓	↓
1	1	0	875
1	1	1	1000

11.1.27 CONFIG

The CONFIG register has the following structure:

Table 40. CONFIG register

CM_VM	Bit 15	Bit 14	Bit 13	Bit 12	Bit 11	Bit 10	Bit 9	Bit 8
0	F_PWM_INT			F_PWM_DEC			VCCVAL	UVLOVAL
1	PRED_EN	TSW					VCCVAL	UVLOVAL
	Bit 7	Bit 6	Bit 5	Bit 4	Bit 3	Bit 2	Bit 1	Bit 0
0	OC_SD		EN_VSCOMP	SW_MODE	EXT_CLK	OSC_SEL		
1	OC_SD		EN_TQREG	SW_MODE	EXT_CLK	OSC_SEL		

The OSC_SEL and EXT_CLK bits set the system clock source:

Table 41. Oscillator management

EXT_CLK	OSC_SEL [2 ... 0]			Clock source	OSCIN	OSCOUT
0	0	0	0	Internal oscillator: 16 MHz	Unused	Unused
0	0	0	1			
0	0	1	0			
0	0	1	1			
1	0	0	0	Internal oscillator: 16 MHz	Unused	Supplies a 2 MHz clock
1	0	0	1	Internal oscillator: 16 MHz	Unused	Supplies a 4 MHz clock
1	0	1	0	Internal oscillator: 16 MHz	Unused	Supplies a 8 MHz clock
1	0	1	1	Internal oscillator: 16 MHz	Unused	Supplies a 16 MHz clock
0	1	0	0	External crystal or resonator: 8 MHz	Crystal/resonator driving	Crystal/resonator driving
0	1	0	1	External crystal or resonator: 16 MHz	Crystal/resonator driving	Crystal/resonator driving
0	1	1	0	External crystal or resonator: 24 MHz	Crystal/resonator driving	Crystal/resonator driving

Table 41. Oscillator management (continued)

EXT_CLK	OSC_SEL [2 ... 0]			Clock source	OSCIN	OSCOUT
0	1	1	1	External crystal or resonator: 32 MHz	Crystal/resonator driving	Crystal/resonator driving
1	1	0	0	Ext clock source: 8 MHz (crystal/resonator driver disabled)	Clock source	Supplies inverted OSCIN signal
1	1	0	1	External clock source: 16 MHz (crystal/resonator driver disabled)	Clock source	Supplies inverted OSCIN signal
1	1	1	0	External clock source: 24 MHz (crystal/resonator driver disabled)	Clock source	Supplies inverted OSCIN signal
1	1	1	1	External clock source: 32 MHz (crystal/resonator driver disabled)	Clock source	Supplies inverted OSCIN signal

The SW_MODE bit sets the external switch to act as HardStop interrupt or not:

Table 42. External switch hard stop interrupt mode

SW_MODE	Switch mode
0	HardStop interrupt
1	User disposal

The OC_SD bit sets if an overcurrent event causes or not the bridges to turn-off; the OCD flag in status register is forced low anyway:

Table 43. Overcurrent event

OC_SD	Overcurrent event
1	Bridges shut down
0	Bridges do not shut down

The VCCVAL bit set the internal V_{CC} regulator output voltage:

Table 44. Programmable V_{CC} voltage regulator output

VCCVAL	V _{CC} voltage
0	7.5 V
1	15 V

The UVLOVAL bit sets the UVLO protection thresholds:

Table 45. Programmable UVLO thresholds

UVLOVAL	V _{ccthOn}	V _{ccthOff}	DV _{BOOTThOn}	DV _{BOOTThOff}
0	6.9 V	6.3 V	6 V	5.5 V
1	10.4 V	10 V	9.2 V	8.8 V

When the device operates in voltage mode, the EN_VSCOMP bit sets if the motor supply voltage compensation is enabled or not.

Table 46. Motor supply voltage compensation enable

EN_VSCOMP	Motor supply voltage compensation
0	Disabled
1	Enabled

When the device operates in voltage mode, the F_PWM_INT bits set the integer division factor of PWM frequency generation:

Table 47. PWM frequency: integer division factor

F_PWM_INT [2 ... 0]			Integer division factor
0	0	0	1
0	0	1	2
0	1	0	3
0	1	1	4
1	0	0	5
1	0	1	6
1	1	0	7
1	1	1	

When the device operates in voltage mode, the F_PWM_DEC bits set the multiplication factor of PWM frequency generation:

Table 48. PWM frequency: multiplication factor

F_PWM_DEC [2 ... 0]			Multiplication factor
0	0	0	0.625
0	0	1	0.75
0	1	0	0.875
0	1	1	1
1	0	0	1.25
1	0	1	1.5
1	1	0	1.75
1	1	1	2

In the following tables all available PWM frequencies are listed according to oscillator frequency, F_PWM_INT and F_PWM_DEC values (CONFIG register OSC_SEL parameter has to be correctly programmed).

Table 49. Available PWM frequencies [kHz]: 8 MHz oscillator frequency

F_PWM_INT	F_PWM_DEC							
	000	001	010	011	100	101	110	111
000	9.8	11.7	13.7	15.6	19.5	23.4	27.3	31.3
001	4.9	5.9	6.8	7.8	9.8	11.7	13.7	15.6
010	3.3	3.9	4.6	5.2	6.5	7.8	9.1	10.4
011	2.4	2.9	3.4	3.9	4.9	5.9	6.8	7.8
100	2.0	2.3	2.7	3.1	3.9	4.7	5.5	6.3
101	1.6	2.0	2.3	2.6	3.3	3.9	4.6	5.2
110	1.4	1.7	2.0	2.2	2.8	3.3	3.9	4.5

Table 50. Available PWM frequencies [kHz]: 16 MHz oscillator frequency

F_PWM_INT	F_PWM_DEC							
	000	001	010	011	100	101	110	111
000	19.5	23.4	27.3	31.3	39.1	46.9	54.7	62.5
001	9.8	11.7	13.7	15.6	19.5	23.4	27.3	31.3
010	6.5	7.8	9.1	10.4	13.0	15.6	18.2	20.8
011	4.9	5.9	6.8	7.8	9.8	11.7	13.7	15.6
100	3.9	4.7	5.5	6.3	7.8	9.4	10.9	12.5

Table 50. Available PWM frequencies [kHz]: 16 MHz oscillator frequency (continued)

	F_PWM_DEC							
F_PWM_INT	000	001	010	011	100	101	110	111
101	3.3	3.9	4.6	5.2	6.5	7.8	9.1	10.4
110	2.8	3.3	3.9	4.5	5.6	6.7	7.8	8.9

Table 51. Available PWM frequencies [kHz]: 24 MHz oscillator frequency

	F_PWM_DEC							
F_PWM_INT	000	001	010	011	100	101	110	111
000	29.3	35.2	41.0	46.9	58.6	70.3	82.0	93.8
001	14.6	17.6	20.5	23.4	29.3	35.2	41.0	46.9
010	9.8	11.7	13.7	15.6	19.5	23.4	27.3	31.3
011	7.3	8.8	10.3	11.7	14.6	17.6	20.5	23.4
100	5.9	7.0	8.2	9.4	11.7	14.1	16.4	18.8
101	4.9	5.9	6.8	7.8	9.8	11.7	13.7	15.6
110	4.2	5.0	5.9	6.7	8.4	10.0	11.7	13.4

Table 52. Available PWM frequencies [kHz]: 32 MHz oscillator frequency

	F_PWM_DEC							
F_PWM_INT	000	001	010	011	100	101	110	111
000	39.1	46.9	54.7	62.5	78.1	93.8	109.4	125.0
001	19.5	23.4	27.3	31.3	39.1	46.9	54.7	62.5
010	13.0	15.6	18.2	20.8	26.0	31.3	36.5	41.7
011	9.8	11.7	13.7	15.6	19.5	23.4	27.3	31.3
100	7.8	9.4	10.9	12.5	15.6	18.8	21.9	25.0
101	6.5	7.8	9.1	10.4	13.0	15.6	18.2	20.8
110	5.6	6.7	7.8	8.9	11.2	13.4	15.6	17.9

When the device operates in current mode, the EN_TQREG bit sets if the peak current is adjusted through the ADCIN input or not.

Table 53. External torque regulation enable

EN_TQREG	Peak current adjust. through ADCIN
0	Disabled
1	Enabled

When the device operates in current mode, the PRED_EN bit sets if the predictive current control method is enabled or not.

Table 54. Motor supply voltage compensation enable

PRED_EN	Predictive current control
0	Disabled
1	Enabled

When the device operates in current mode, the TSW bits set the target switching period of the current control algorithm:

Table 55. Switching period

TSW [4 ... 0]					Switching period
0	0	0	0	0	4 μ s (250 kHz)
0	0	0	0	1	4 μ s (250 kHz)
0	0	0	1	0	8 μ s (125 kHz)
⋮					⋮
1	1	1	1	1	124 μ s (8 kHz)

Any attempt to write the CONFIG register when the outputs are enabled causes the command to be ignored and the CMD_ERROR flag to rise (see [Section 11.1.28](#)).

11.1.28 STATUS

The STATUS register has the following structure:

Table 56. STATUS register

Bit 15	Bit 14	Bit 13	Bit 12	Bit 11	Bit 10	Bit 9	Bit 15
STALL_A	STALL_B	OCD	TH_STATUS		UVLO_ADC	UVLO	STCK_MOD
Bit 7	Bit 6	Bit 5	Bit 4	Bit 3	Bit 2	Bit 1	Bit 0
CMD_ERROR	MOT_STATUS		DIR	SW_EVN	SW_F	BUSY	HiZ

When HiZ flag is high it indicates that the bridges are in high impedance state. Whichever motion command makes the device to exit from High Z state (HardStop and SoftStop included), unless error flags forcing a High Z state are active.

The UVLO flag is active low and is set by an undervoltage lock out or reset events (power-up included).

The UVLO_ADC flag is active low and indicates an ADC undervoltage event.

The OCD flag is active low and indicates an overcurrent detection event.

The STALL_A and STALL_B flags are forced low when a stall condition is detected on bridge A or bridge B respectively. The stall detection is operative only when the voltage mode control is selected.

The CMD_ERROR flag is active high and indicates that the command received by SPI can't be performed or does not exist at all.

The SW_F report the SW input status (low for open and high for closed).

The SW_EVN flag is active high and indicates a switch turn-on event (SW input falling edge).

TH_STATUS bits indicate the current device thermal status (see [Section 7.12 on page 32](#)):

Table 57. STATUS register TH_STATUS bits

TH_STATUS		Status
0	0	Normal
0	1	Warning
1	0	Bridge shutdown
1	1	Device shutdown

UVLO, UVLO_ADC, OCD, STEP_LOSS_A, STEP_LOSS_B, CMD_ERROR, SW_EVN and TH_STATUS bits are latched: when the respective conditions make them active (low or high) they remain in that state until a GetStatus command is sent to the IC.

The BUSY bit reflects the BUSY pin status. The BUSY flag is low when a constant speed, positioning or motion command is under execution and is released (high) after the command have been completed.

The STCK_MOD bit is an active high flag indicating that the device is working in step clock mode. In this case the step clock signal should be provided through STCK input pin.

The DIR bit indicates the current motor direction:

Table 58. STATUS register DIR bit

DIR	Motor direction
1	Forward
0	Reverse

MOT_STATUS indicates the current motor status:

Table 59. STATUS register MOT_STATUS bits

MOT_STATUS		Motor status
0	0	Stopped
0	1	Acceleration
1	0	Deceleration
1	1	Constant speed

Any attempt to write to the register causes the command to be ignored and the CMD_ERROR flag to rise.

11.2 Application commands

The command summary is given in [Table 60](#).

Table 60. Application commands

Command mnemonic	Command binary code					Action
	[7...5]	[4]	[3]	[2...1]	[0]	
NOP	000	0	0	00	0	Nothing
SetParam(PARAM,VALUE)	000	[PARAM]				Writes VALUE in PARAM register
GetParam(PARAM)	001	[PARAM]				Returns the stored value in PARAM register
Run(DIR,SPD)	010	1	0	00	DIR	Sets the target speed and the motor direction
StepClock(DIR)	010	1	1	00	DIR	Puts the device in Step-clock mode and imposes DIR direction
Move(DIR,N_STEP)	010	0	0	00	DIR	Makes N_STEP (micro)steps in DIR direction (Not performable when motor is running)
GoTo(ABS_POS)	011	0	0	00	0	Brings motor in ABS_POS position (minimum path)
GoTo_DIR(DIR,ABS_POS)	011	0	1	00	DIR	Brings motor in ABS_POS position forcing DIR direction
GoUntil(ACT,DIR,SPD)	100	0	ACT	01	DIR	Performs a motion in DIR direction with speed SPD until SW is closed, the ACT action is executed then a SoftStop takes place
ReleaseSW(ACT, DIR)	100	1	ACT	01	DIR	Performs a motion in DIR direction at minimum speed until the SW is released (open), the ACT action is executed then a HardStop takes place
GoHome	011	1	0	00	0	Brings the motor in HOME position
GoMark	011	1	1	00	0	Brings the motor in MARK position
ResetPos	110	1	1	00	0	Resets the ABS_POS register (sets HOME position)
ResetDevice	110	0	0	00	0	Device is reset to power-up conditions
SoftStop	101	1	0	00	0	Stops motor with a deceleration phase
HardStop	101	1	1	00	0	Stops motor immediately
SoftHiZ	101	0	0	00	0	Puts the bridges in high impedance status after a deceleration phase
HardHiZ	101	0	1	00	0	Puts the bridges in high impedance status immediately
GetStatus	110	1	0	00	0	Returns the status register value
RESERVED	111	0	1	01	1	RESERVED COMMAND
RESERVED	111	1	1	00	0	RESERVED COMMAND

11.2.1 Command management

The host microcontroller can control motor motion and configure the powerSTEP01 through a complete set of commands.

All commands are composed by a single byte. After the command byte, some bytes of arguments should be needed (see [Figure 27](#)). Argument length can vary from 1 to 3 bytes.

Figure 27. Command with 3-byte argument

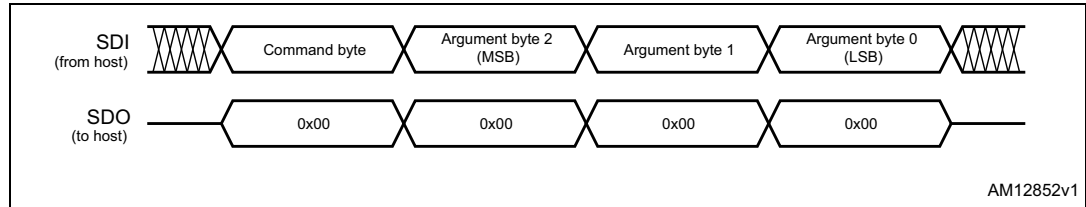

By default, the device returns an all zero response for any received byte, the only exceptions are GetParam and GetStatus commands. When one of these commands is received, the following response bytes represent the related register value (see [Figure 28](#)). Response length can vary from 1 to 3 bytes.

Figure 28. Command with 3-byte response

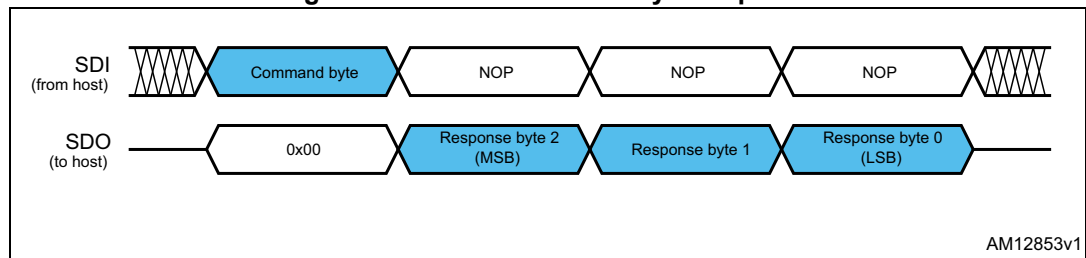

During response transmission, new commands can be sent. If a command requiring a response is sent before the previous response is completed, the response transmission is aborted and the new response is loaded into the output communication buffer (see [Figure 29](#)).

Figure 29. Command response aborted

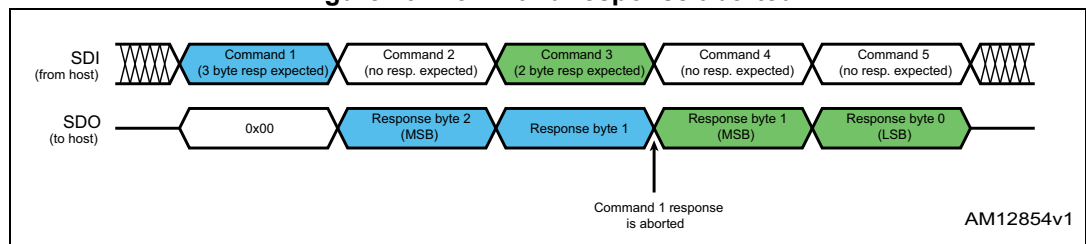

When a byte that does not correspond to a command is sent to the IC it is ignored and the CMD_ERROR flag in the STATUS register is raised (see paragraph [Section 11.1.28](#)).

11.2.2 Nop

Table 61. Nop command structure

Bit 7	Bit 6	Bit 5	Bit 4	Bit 3	Bit 2	Bit 1	Bit 0	
0	0	0	0	0	0	0	0	From host

Nothing is performed.

11.2.3 SetParam (PARAM, VALUE)

Table 62. SetParam command structure

Bit 7	Bit 6	Bit 5	Bit 4	Bit 3	Bit 2	Bit 1	Bit 0	
0	0	0	PARAM				From host	
VALUE byte 2 (if needed)								
VALUE byte 1 (if needed)								
VALUE byte 0								

The SetParam command sets the PARAM register value equal to VALUE; PARAM is the respective register address listed in [Table 12 on page 51](#).

The command should be followed by the new register VALUE (most significant byte first). The number of bytes composing the VALUE argument depends on the length of the target register (see [Table 12](#)).

Some registers cannot be written (see [Table 12](#)); any attempt to write one of those registers causes the command to be ignored and the CMD_ERROR flag to rise at the end of the command byte, as if an unknown command code were sent (see [Section 11.1.28 on page 71](#)).

Some registers can only be written in particular conditions (see [Table 12](#)); any attempt to write one of those registers when the conditions are not satisfied causes the command to be ignored and the CMD_ERROR flag to rise at the end of the last argument byte (see [Section 11.1.28](#)).

Any attempt to set an inexistent register (wrong address value) causes the command to be ignored and the CMD_ERROR flag to rise at the end of the command byte as if an unknown command code were sent.

11.2.4 GetParam (PARAM)

Table 63. GetParam command structure

Bit 7	Bit 6	Bit 5	Bit 4	Bit 3	Bit 2	Bit 1	Bit 0	
0	0	1	PARAM				From host	
ANS byte 2 (if needed)						To host		
ANS byte 1 (if needed)						To host		
ANS byte 0						To host		

This command reads the current PARAM register value; PARAM is the respective register address listed in [Table 12 on page 51](#).

The command response is the current value of the register (most significant byte first). The number of bytes composing the command response depends on the length of the target register (see [Table 12](#)).

The returned value is the register one at the moment of GetParam command decoding. If register values change after this moment, the response is not accordingly updated.

All registers can be read anytime.

Any attempt to read an inexistent register (wrong address value) causes the command to be ignored and the CMD_ERROR flag to rise at the end of the command byte as if an unknown command code were sent.

11.2.5 Run (DIR, SPD)

Table 64. Run command structure

Bit 7	Bit 6	Bit 5	Bit 4	Bit 3	Bit 2	Bit 1	Bit 0	
0	1	0	1	0	0	0	DIR	From host
X	X	X	X	SPD (byte 2)				From host
SPD (byte 1)								From host
SPD (byte 0)								From host

The Run command produces a motion at SPD speed; the direction is selected by the DIR bit: '1' forward or '0' reverse. The SPD value is expressed in step/tick (format unsigned fixed point 0.28) that is the same format as the SPEED register ([Section 11.1.4 on page 53](#)).

Note: The SPD value should be lower than MAX_SPEED and greater than MIN_SPEED, otherwise the Run command is executed at MAX_SPEED or MIN_SPEED respectively.

This command keeps the BUSY flag low until the target speed is reached.

This command can be given anytime and is immediately executed.

11.2.6 StepClock (DIR)

Table 65. StepClock command structure

Bit 7	Bit 6	Bit 5	Bit 4	Bit 3	Bit 2	Bit 1	Bit 0	
0	1	0	1	1	0	0	DIR	From host

The StepClock command switches the device in Step-clock mode ([Section 7.7.5 on page 28](#)) and imposes the forward (DIR = '1') or reverse (DIR = '0') direction.

When the device is in Step-clock mode, the SCK_MOD flag in the STATUS register is raised and the motor is always considered stopped ([Section 7.7.5](#) and [Section 11.1.28 on page 71](#)).

The device exits Step-clock mode when a constant speed, absolute positioning or motion command is sent through SPI. Motion direction is imposed by the respective StepClock

command argument and can be changed by a new StepClock command without exiting Step-clock mode.

Events that cause bridges to be forced into high impedance state (overtemperature, overcurrent, etc.) do not cause the device to leave Step-clock mode.

The StepClock command does not force the BUSY flag low. This command can only be given when the motor is stopped. If a motion is in progress, the motor should be stopped and it is then possible to send a StepClock command.

Any attempt to perform a StepClock command when the motor is running causes the command to be ignored and the CMD_ERROR flag to rise ([Section 11.1.28 on page 71](#)).

11.2.7 Move (DIR, N_STEP)

Table 66. Move command structure

Bit 7	Bit 6	Bit 5	Bit 4	Bit 3	Bit 2	Bit 1	Bit 0	
0	1	0	0	0	0	0	DIR	From host
X	X	N_STEP (byte 2)						From host
N_STEP (byte 1)								From host
N_STEP (byte 0)								From host

The move command produces a motion of N_STEP microsteps; the direction is selected by the DIR bit ('1' forward or '0' reverse).

The N_STEP value is always in agreement with the selected step mode; the parameter value unit is equal to the selected step mode (full, half, quarter, etc.).

This command keeps the BUSY flag low until the target number of steps is performed. This command can only be performed when the motor is stopped. If a motion is in progress the motor must be stopped and it is then possible to perform a move command.

Any attempt to perform a move command when the motor is running causes the command to be ignored and the CMD_ERROR flag to rise ([Section 11.1.28](#)).

11.2.8 GoTo (ABS_POS)

Table 67. GoTo command structure

Bit 7	Bit 6	Bit 5	Bit 4	Bit 3	Bit 2	Bit 1	Bit 0	
0	1	1	0	0	0	0	0	From host
X	X	ABS_POS (byte 2)						From host
ABS_POS (byte 1)								From host
ABS_POS (byte 0)								From host

The GoTo command produces a motion to ABS_POS absolute position through the shortest path. The ABS_POS value is always in agreement with the selected step mode; the parameter value unit is equal to the selected step mode (full, half, quarter, etc.).

The GoTo command keeps the BUSY flag low until the target position is reached.

This command can be given only when the previous motion command as been completed (BUSY flag released).

Any attempt to perform a GoTo command when a previous command is under execution (BUSY low) causes the command to be ignored and the CMD_ERROR flag to rise ([Section 11.1.28 on page 71](#)).

11.2.9 GoTo_DIR (DIR, ABS_POS)

Table 68. GoTo_DIR command structure

Bit 7	Bit 6	Bit 5	Bit 4	Bit 3	Bit 2	Bit 1	Bit 0		
0	1	1	0	1	0	0	DIR	From host	
X	X	ABS_POS (byte 2)							From host
ABS_POS (byte 1)								From host	
ABS_POS (byte 0)								From host	

The GoTo_DIR command produces a motion to ABS_POS absolute position imposing a forward (DIR = '1') or a reverse (DIR = '0') rotation. The ABS_POS value is always in agreement with the selected step mode; the parameter value unit is equal to the selected step mode (full, half, quarter, etc.).

The GoTo_DIR command keeps the BUSY flag low until the target speed is reached. This command can be given only when the previous motion command has been completed (BUSY flag released).

Any attempt to perform a GoTo_DIR command when a previous command is under execution (BUSY low) causes the command to be ignored and the CMD_ERROR flag to rise ([Section 11.1.28](#)).

11.2.10 GoUntil (ACT, DIR, SPD)

Table 69. GoUntil command structure

Bit 7	Bit 6	Bit 5	Bit 4	Bit 3	Bit 2	Bit 1	Bit 0	
1	0	0	0	ACT	0	1	DIR	From host
X	X	X	X	SPD (byte 2)				From host
SPD (byte 1)								From host
SPD (byte 0)								From host

The GoUntil command produces a motion at SPD speed imposing a forward (DIR = '1') or a reverse (DIR = '0') direction. When an external switch turn-on event occurs ([Section 7.14 on page 33](#)), the ABS_POS register is reset (if ACT = '0') or the ABS_POS register value is copied into the MARK register (if ACT = '1'); the system then performs a SoftStop command.

The SPD value is expressed in step/tick (format unsigned fixed point 0.28) that is the same format as the SPEED register ([Section 11.1.4 on page 53](#)).

The SPD value should be lower than MAX_SPEED and greater than MIN_SPEED, otherwise the target speed is imposed at MAX_SPEED or MIN_SPEED respectively.

If the SW_MODE bit of the CONFIG register is set low, the external switch turn-on event causes a HardStop interrupt instead of the SoftStop one ([Section 7.14 on page 33](#) and [Section 11.1.27 on page 66](#)).

This command keeps the BUSY flag low until the switch turn-on event occurs and the motor is stopped. This command can be given anytime and is immediately executed.

11.2.11 ReleaseSW (ACT, DIR)

Table 70. ReleaseSW command structure

Bit 7	Bit 6	Bit 5	Bit 4	Bit 3	Bit 2	Bit 1	Bit 0	
1	0	0	1	ACT	0	1	DIR	From host

The ReleaseSW command produces a motion at minimum speed imposing a forward (DIR = '1') or reverse (DIR = '0') rotation. When SW is released (opened) the ABS_POS register is reset (ACT = '0') or the ABS_POS register value is copied into the MARK register (ACT = '1'); the system then performs a HardStop command.

Note that, resetting the ABS_POS register is equivalent to setting the HOME position.

If the minimum speed value is less than 5 step/s or low speed optimization is enabled, the motion is performed at 5 step/s.

The ReleaseSW command keeps the BUSY flag low until the switch input is released and the motor is stopped.

11.2.12 GoHome

Table 71. GoHome command structure

Bit 7	Bit 6	Bit 5	Bit 4	Bit 3	Bit 2	Bit 1	Bit 0	
0	1	1	1	0	0	0	0	From host

The GoHome command produces a motion to the HOME position (zero position) via the shortest path.

Note that, this command is equivalent to the "GoTo(0...0)" command. If a motor direction is mandatory, the GoTo_DIR command must be used ([Section 11.2.9 on page 78](#)).

The GoHome command keeps the BUSY flag low until the home position is reached. This command can be given only when the previous motion command has been completed. Any attempt to perform a GoHome command when a previous command is under execution (BUSY low) causes the command to be ignored and the CMD_ERROR to rise ([Section 11.1.28 on page 71](#)).

11.2.13 GoMark

Table 72. GoMark command structure

Bit 7	Bit 6	Bit 5	Bit 4	Bit 3	Bit 2	Bit 1	Bit 0	
0	1	1	1	1	0	0	0	From host

The GoMark command produces a motion to the MARK position performing the minimum path.

Note that, this command is equivalent to the “GoTo (MARK)” command. If a motor direction is mandatory, the GoTo_DIR command must be used.

The GoMark command keeps the BUSY flag low until the MARK position is reached. This command can be given only when the previous motion command has been completed (BUSY flag released).

Any attempt to perform a GoMark command when a previous command is under execution (BUSY low) causes the command to be ignored and the CMD_ERROR flag to rise ([Section 11.1.28 on page 71](#)).

11.2.14 ResetPos

Table 73. ResetPos command structure

Bit 7	Bit 6	Bit 5	Bit 4	Bit 3	Bit 2	Bit 1	Bit 0	
1	1	0	1	1	0	0	0	From host

The ResetPos command resets the ABS_POS register to zero. The zero position is also defined as the HOME position ([Section 7.5 on page 25](#)).

11.2.15 ResetDevice

Table 74. ResetDevice command structure

Bit 7	Bit 6	Bit 5	Bit 4	Bit 3	Bit 2	Bit 1	Bit 0	
1	1	0	0	0	0	0	0	From host

The ResetDevice command resets the device to power-up conditions ([Section 7.1 on page 22](#)).

Note: At power-up the power bridges are disabled.

11.2.16 SoftStop

Table 75. SoftStop command structure

Bit 7	Bit 6	Bit 5	Bit 4	Bit 3	Bit 2	Bit 1	Bit 0	
1	0	1	1	0	0	0	0	From host

The SoftStop command causes an immediate deceleration to zero speed and a consequent motor stop; the deceleration value used is the one stored in the DEC register ([Section 11.1.6 on page 54](#)).

When the motor is in high impedance state, a SoftStop command forces the bridges to exit from high impedance state; no motion is performed.

This command can be given anytime and is immediately executed. This command keeps the BUSY flag low until the motor is stopped.

11.2.17 HardStop

Table 76. HardStop command structure

Bit 7	Bit 6	Bit 5	Bit 4	Bit 3	Bit 2	Bit 1	Bit 0	
1	0	1	1	1	0	0	0	From host

The HardStop command causes an immediate motor stop with infinite deceleration.

When the motor is in high impedance state, a HardStop command forces the bridges to exit high impedance state; no motion is performed.

This command can be given anytime and is immediately executed. This command keeps the BUSY flag low until the motor is stopped.

11.2.18 SoftHiZ

Table 77. SoftHiZ command structure

Bit 7	Bit 6	Bit 5	Bit 4	Bit 3	Bit 2	Bit 1	Bit 0	
1	0	1	0	0	0	0	0	From host

The SoftHiZ command disables the power bridges (high impedance state) after a deceleration to zero; the deceleration value used is the one stored in the DEC register ([Section 11.1.6](#)). When bridges are disabled, the HiZ flag is raised.

When the motor is stopped, a SoftHiZ command forces the bridges to enter high impedance state.

This command can be given anytime and is immediately executed. This command keeps the BUSY flag low until the motor is stopped.

11.2.19 HardHiZ

Table 78. HardHiZ command structure

Bit 7	Bit 6	Bit 5	Bit 4	Bit 3	Bit 2	Bit 1	Bit 0	
1	0	1	0	1	0	0	0	From host

The HardHiZ command immediately disables the power bridges (high impedance state) and raises the HiZ flag.

When the motor is stopped, a HardHiZ command forces the bridges to enter high impedance state.

This command can be given anytime and is immediately executed.

This command keeps the BUSY flag low until the motor is stopped.

11.2.20 GetStatus

Table 79. GetStatus command structure

Bit 7	Bit 6	Bit 5	Bit 4	Bit 3	Bit 2	Bit 1	Bit 0	
1	1	0	1	0	0	0	0	From host
STATUS MSbyte								To host
STATUS LSbyte								To host

The GetStatus command returns the Status register value.

The GetStatus command resets the STATUS register warning flags. The command forces the system to exit from any error state. The GetStatus command DOES NOT reset the HiZ flag.

12 Package information

In order to meet environmental requirements, ST offers these devices in different grades of ECOPACK® packages, depending on their level of environmental compliance. ECOPACK specifications, grade definitions and product status are available at: www.st.com. ECOPACK is an ST trademark.

VFQFPN package information

Figure 30. VFQFPN 11 x 14 x 1.0 - 9 die pads drawing - side view

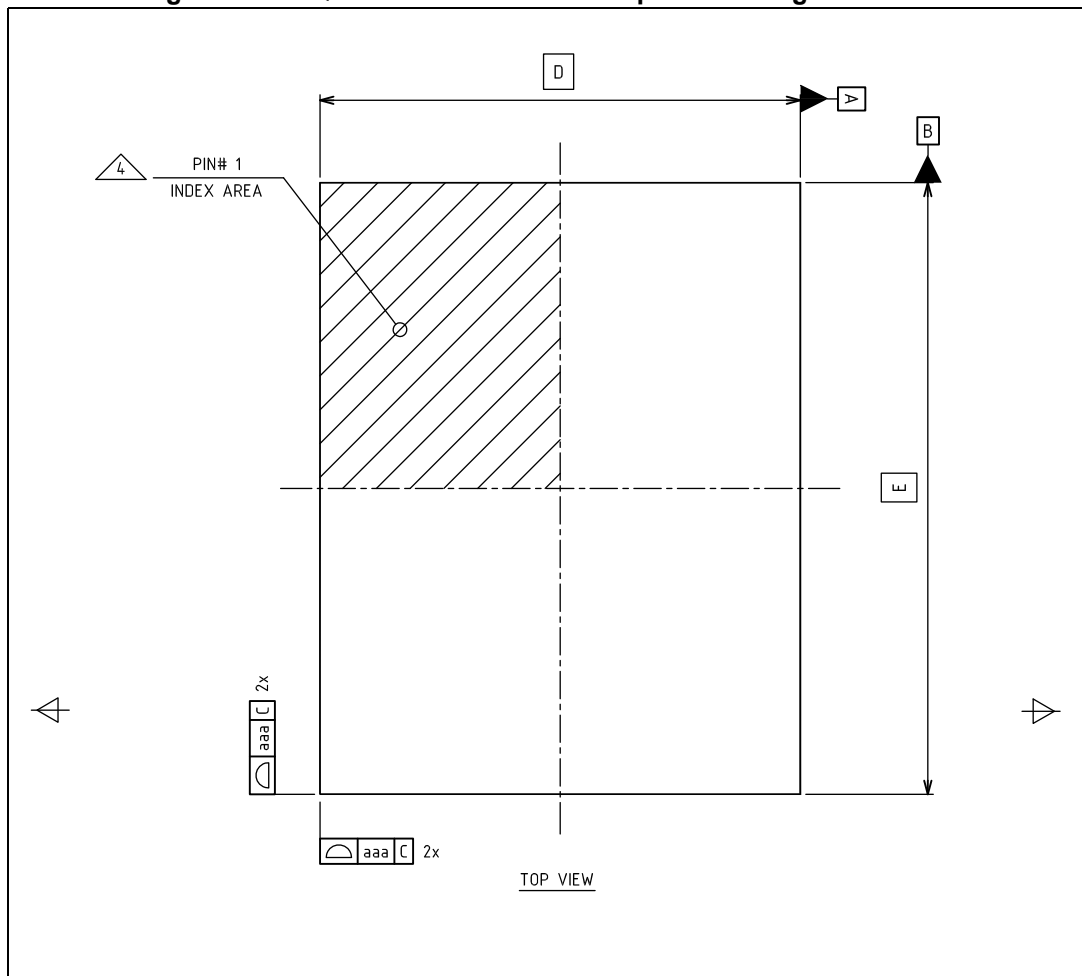

Figure 31. VFQFPN 11 x 14 x 1.0 - 9 die pads drawing - bottom view

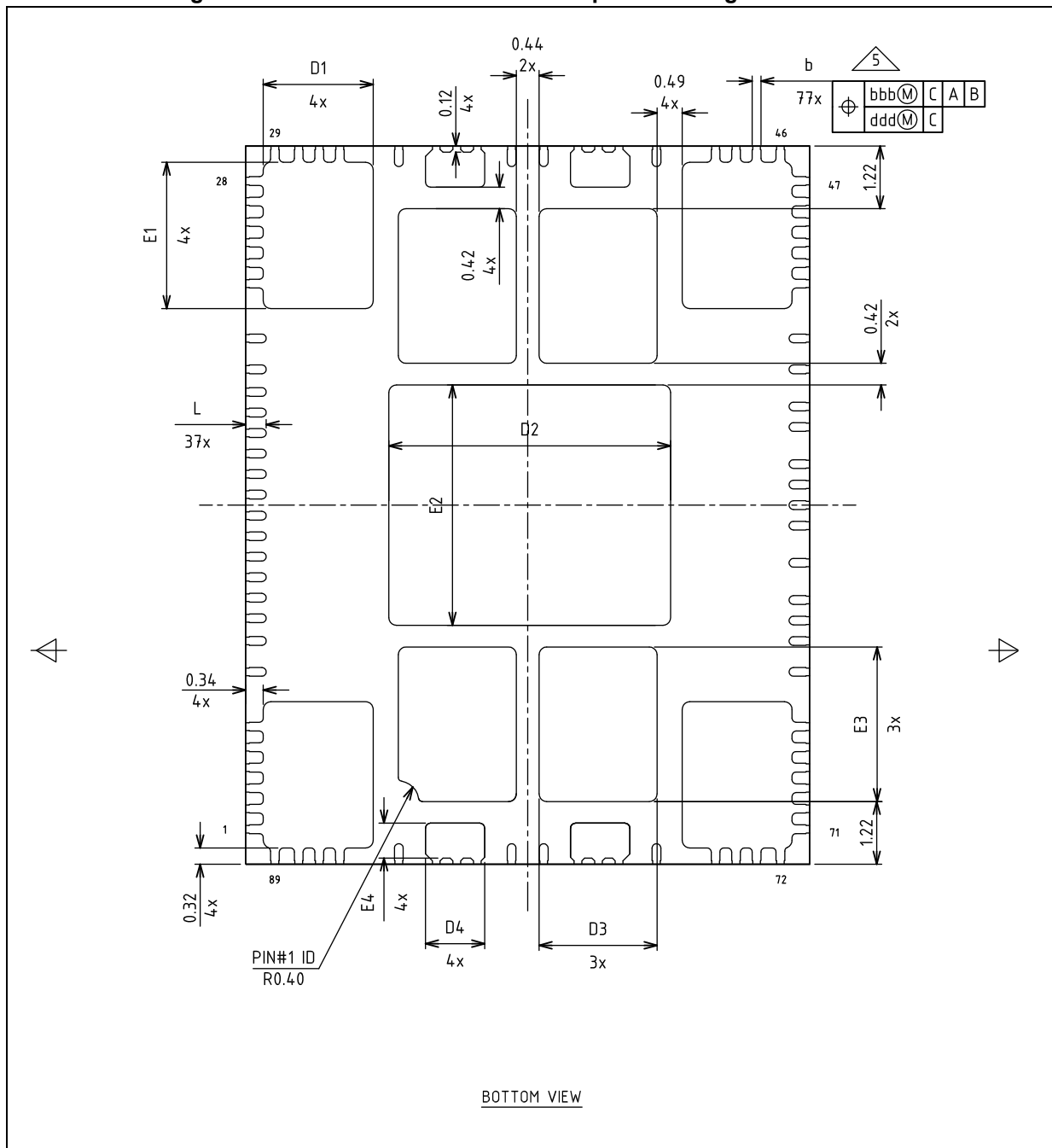

Figure 32. VFQFPN 11 x 14 x 1.0 - 9 die pads drawing - pin identifier

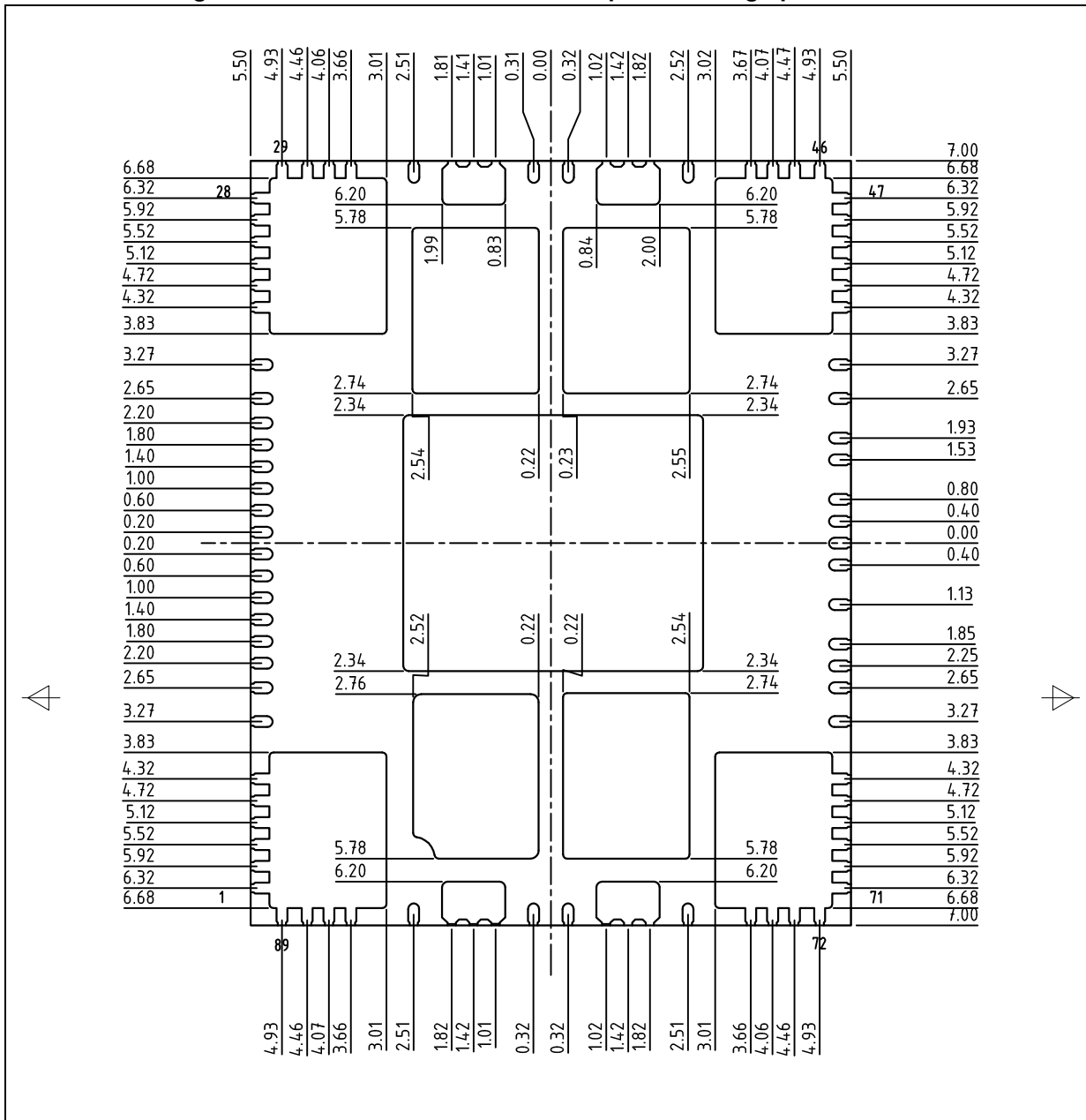
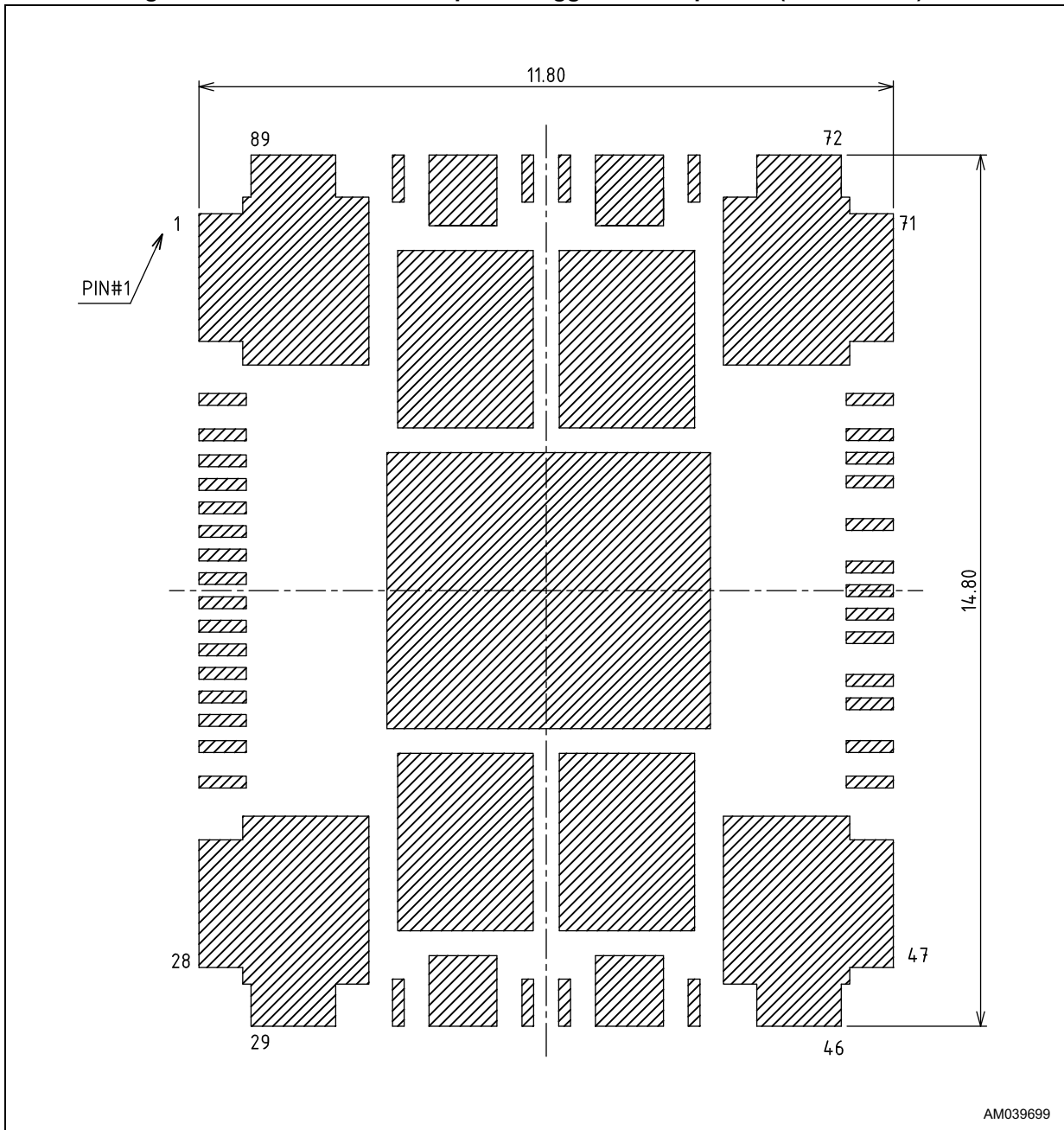

Table 80. VFQFPN 11 x 14 x 1.0 - 9 die pads - 89 leads^{(1), (2), (3), (4), (5)}

Symbol	Dimensions (mm)			Note
	Min.	Typ.	Max.	
A	0.80	0.90	1.00	(6)
A1	0.00	0.02	0.05	
A3	---	0.20 ref.	---	
b	0.15	0.2	0.25	(7)
D	10.90	11.00	11.10	
E	13.90	14.00	14.10	
D1	2.00	2.15	2.25	
E1	2.70	2.85	2.95	
D2	5.35	5.50	5.60	
E2	4.54	4.69	4.79	
D3	2.17	2.32	2.42	
E3	2.88	3.03	3.13	
D4	1.01	1.16	1.26	
E4	0.54	0.69	0.79	
L	0.3	0.4	0.5	
aaa	0.10			
bbb	0.10			
ccc	0.10			
ddd	0.05			
eee	0.08			
N	89			(8)
LF part no.	443448			

1. The pin #1 identifier must exist on the top surface of the package by using indentation mark or other feature of package body. Exact shape and size of this feature is optional.
2. Dimensioning and tolerances conform to ASME Y14.5-2009.
3. All dimensions are in millimeters.
4. The location of the marked terminal #1 identifier is within the hatched area.
5. Coplanarity applies to the terminals and all other bottom surface metalization.
6. VFQFPN stands for "Thermally Enhanced Very thin Fine pitch Quad Flat Packages No lead".
Very thin: 0.80 mm < A < 1.00 mm / fine pitch: e < 1.00 mm.
7. Dimension b applies to the metalized terminal and is measured between 0.15 mm and 0.30 mm from the terminal tip. If the terminal has a radius on the other end of it, dimension b should not be measured in that radius area.
8. N is the total number of terminals.

Figure 33. Recommended footprint - suggested landpattern (overall view)⁽¹⁾



1. All dimensions are in mm.

Figure 34. Recommended footprint - lead land positioning(1)

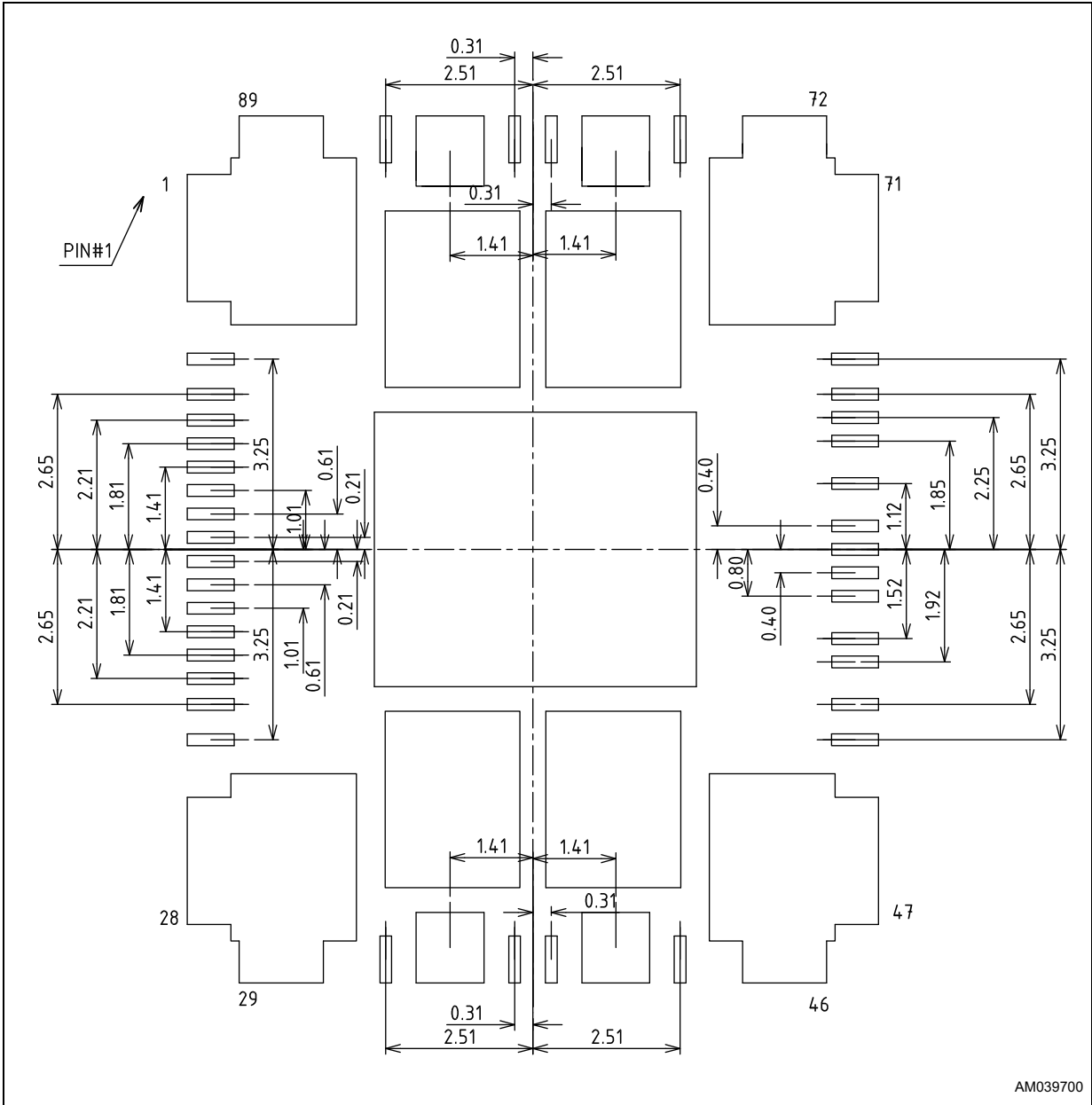

1. All dimensions are in mm.

Figure 35. Recommended footprint - land size and exposed pad positioning⁽¹⁾

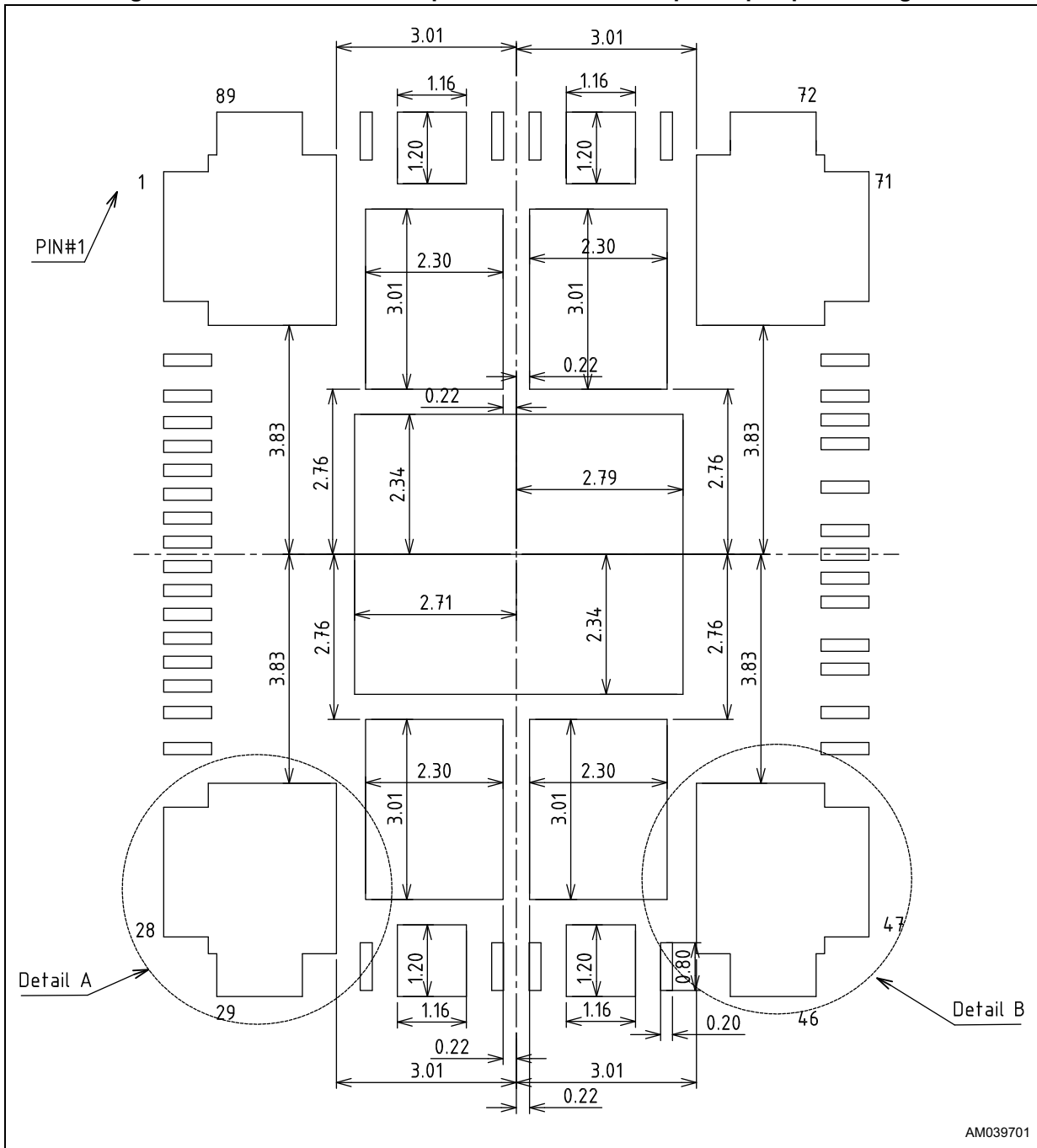

1. All dimensions are in mm.

Figure 36. Recommended footprint - detail A and B drawing⁽¹⁾

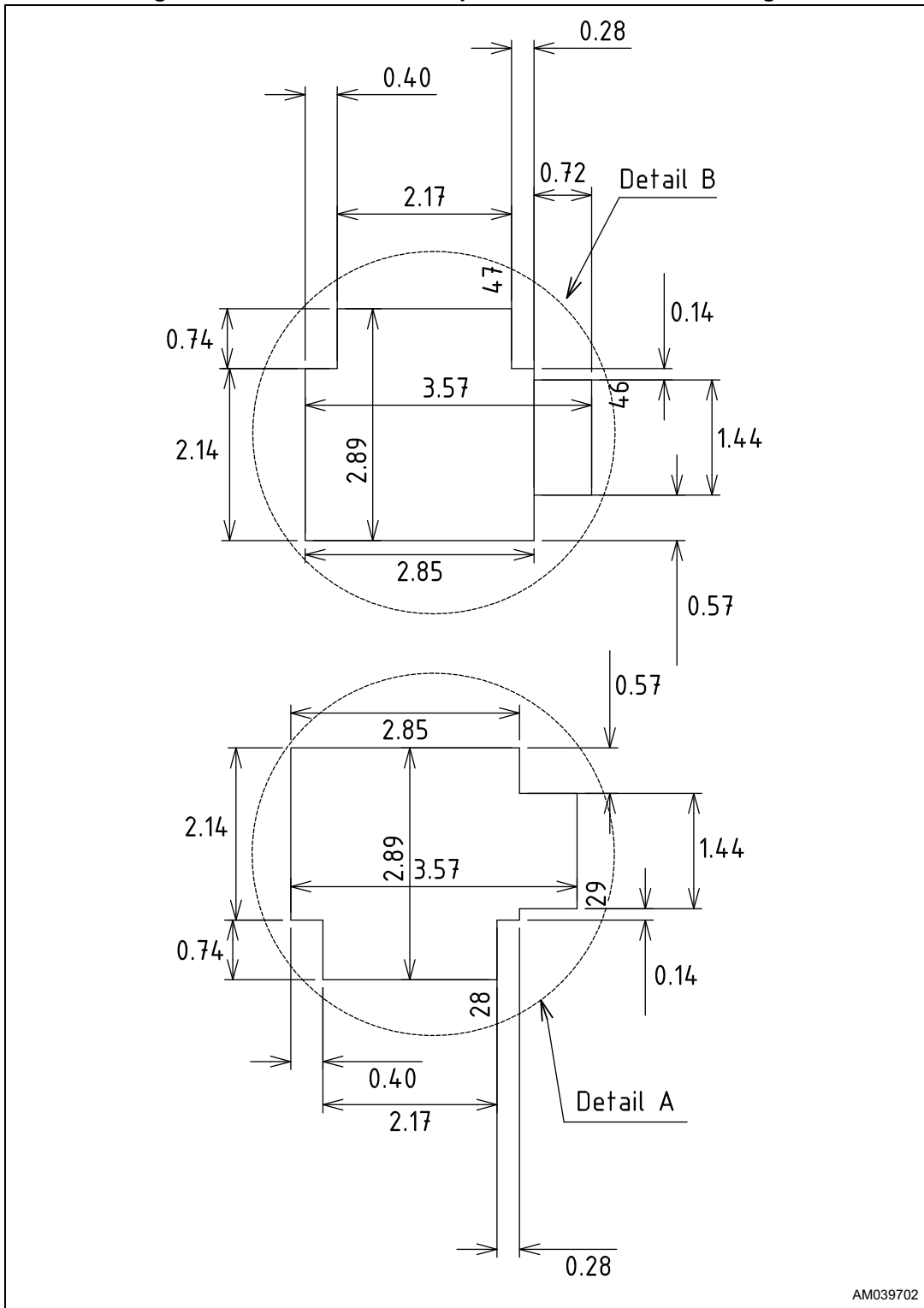

AM039702

1. All dimensions are in mm.

13 Revision history

Table 81. Document revision history

Date	Revision	Changes
22-Jul-2013	1	Initial release.
16-Jun-2014	2	Several modifications.
03-Oct-2014	3	Updated main title on page 1 (replaced “8-N channel” by “10 A”). Updated package silhouette on page 1 (replaced by new figure). Updated Section : Applications on page 1 (added sub-list). Updated Table 2 on page 10 (removed “P _{tot} ”, “Peak” and unit of I _{OUT1x} symbol). Updated Table 4 on page 12 (updated “Test conditions” and values of R _{DS(on)} , SR _{OUT} , I _{DSS} and t _{OCD,SD} symbols). Added Section 7.15 on page 34 . Minor modifications throughout document.
22-Apr-2015	4	Document updated from “preliminary” to “production data”. Updated Table 4 on page 12 (updated max. values). Updated Table 5 on page 18 (updated pin no. of OUTA1). Updated Table 8 on page 32 [replaced “Of” by “On” in High-side gate driver supply turn-on threshold ($\Delta V_{BOOT_{thon}}$)]. Updated Table 12 on page 51 (updated length column of STEP_MODE and FS_SPD). Updated Table 15 on page 55 (removed Bit 11 column). Updated Section 12: Package information on page 83 (replaced Figure 30 to Figure 32 and Table 80 by new figures/table). Minor modifications throughout document.
10-Jun-2015	5	Updated Table 4 on page 12 (updated max. values). Updated Table 45 on page 68 (updated values). Added Figure 33 on page 87 to Figure 36 on page 90 . Minor modifications throughout document.

IMPORTANT NOTICE – PLEASE READ CAREFULLY

STMicroelectronics NV and its subsidiaries ("ST") reserve the right to make changes, corrections, enhancements, modifications, and improvements to ST products and/or to this document at any time without notice. Purchasers should obtain the latest relevant information on ST products before placing orders. ST products are sold pursuant to ST's terms and conditions of sale in place at the time of order acknowledgement.

Purchasers are solely responsible for the choice, selection, and use of ST products and ST assumes no liability for application assistance or the design of Purchasers' products.

No license, express or implied, to any intellectual property right is granted by ST herein.

Resale of ST products with provisions different from the information set forth herein shall void any warranty granted by ST for such product.

ST and the ST logo are trademarks of ST. All other product or service names are the property of their respective owners.

Information in this document supersedes and replaces information previously supplied in any prior versions of this document.

© 2015 STMicroelectronics – All rights reserved