



## PM6686

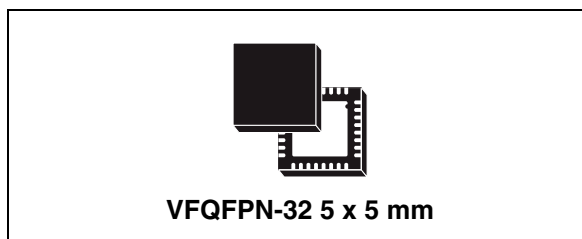
### Dual step-down controller with adjustable voltages, adjustable LDO and auxiliary charge pump controller for notebook

#### Features

- 5.5 V to 28 V input voltage range
- Dual fixed OUT1 = 1.5 V/5 V and OUT2 = 1.05 V / 3.3 V outputs or adjustable OUT1 = 0.7 V to 5.5 V and OUT2 = 0.7 V to 2.5 V outputs,  $\pm 1.5\%$  accuracy over valley regulation
- Low-side MOSFETs'  $R_{DS(on)}$  current sensing and programmable current limit
- Constant ON-time control
- Frequency selectable
- Soft-start internally fixed at 2 ms and soft-stop
- Selectable pulse skipping at light loads
- Selectable minimum frequency (33 kHz) in pulse skip mode
- Independent Power Good and EN signals
- Latched OVP and UVP
- Charge pump feedback
- Fixed 3.3 V/5.0 V, or adjustable output 0.7 V to 4.5 V,  $\pm 1.5\%$  (LDO): 200 mA
- 3.3 V reference voltage  $\pm 2.0\%$ : 5 mA
- 2.0 V reference voltage  $\pm 1.0\%$ : 50  $\mu$ A

#### Applications

- Notebook computers
- Main (3.3 V/5 V), chipset (1.5 V/1.05 V), DDR1/2/3, graphic cards power supply
- PDAs, mobile devices, tablet PC or slates
- 3-4 cells Li+ battery powered devices



#### Description

PM6686 is a dual step-down controller specifically designed to provide extremely high efficiency conversion, with lossless current sensing technique. The constant on-time architecture assures fast load transient response and the embedded voltage feed-forward provides nearly constant switching frequency operation. Pulse skipping technique increases efficiency at very light load. Moreover a minimum switching frequency of 33 kHz is selectable to avoid audio noise issues. The PM6686 provides a selectable switching frequency, allowing three different values of switching frequencies for the two switching sections. The output voltages OUT1 and OUT2 can be programmed to regulate 1.5 V/5 V and 1.05 V/3.3 V outputs respectively or can deliver two adjustable output voltages. An optional external charge pump can be monitored. This device embeds a linear regulator that can provide 3.3 V/5 V or an adjustable voltage from 0.7 V to 4.5 V output. The linear regulator provides up to 100 mA output current. LDO can be bypassed with the switching regulator outputs or with an external power supply (switchover function).

When in switchover, the LDO output can source up to 200 mA.

Table 1. Device summary

Order codes	Package	Packaging
PM6686	VFQFPN-32L 5 x 5 mm	Tray
PM6686TR		Tape and reel

# Contents

- 1      Simplified application schematic ..... 6**
- 2      Pin settings ..... 7**
  - 2.1    Connections ..... 7
  - 2.2    Pin descriptions ..... 7
- 3      Electrical data ..... 10**
  - 3.1    Maximum rating ..... 10
  - 3.2    Thermal data ..... 10
- 4      Recommended operating conditions ..... 11**
- 5      Electrical characteristics ..... 12**
- 6      Typical operating characteristics ..... 15**
  - 6.1    Screen shots ..... 19
- 7      Block diagram ..... 23**
- 8      Device description ..... 24**
  - 8.1    Switching sections ..... 24
    - 8.1.1    Output voltage set up ..... 24
    - 8.1.2    Constant on time control (COT) ..... 26
    - 8.1.3    PWM ..... 28
    - 8.1.4    SKIP ..... 29
    - 8.1.5    Non audible SKIP (NA SKIP) ..... 29
    - 8.1.6    Gate drivers and logic supply ..... 30
    - 8.1.7    Current sensing and current limit ..... 31
    - 8.1.8    Soft-start and soft-end ..... 32
- 9      Monitoring and protections ..... 34**
  - 9.1    Overvoltage protection ..... 34
  - 9.2    Undervoltage protection ..... 34
  - 9.3    PVCC monitor ..... 34

---

9.4	Linear regulator section .....	35
9.5	Charge pump .....	36
9.6	Voltage references .....	37
9.7	General device fault management .....	37
9.7.1	Thermal protection .....	37
<b>10</b>	<b>Application information .....</b>	<b>38</b>
10.1	External components selection .....	38
10.1.1	Inductor .....	38
10.1.2	Input capacitor .....	39
10.1.3	Output capacitor .....	39
10.1.4	MOSFET .....	40
<b>11</b>	<b>Diode selection .....</b>	<b>42</b>
11.1	Freewheeling diode .....	42
11.2	Charge pump diode .....	42
11.3	Other important components .....	43
11.3.1	VIN filter .....	43
11.3.2	PVCC and VCC .....	43
11.3.3	VREF2 and VREF3 capacitors .....	44
11.3.4	LDO output capacitors .....	44
11.3.5	Bootstrap circuit .....	44
<b>12</b>	<b>PCB design guidelines .....</b>	<b>45</b>
<b>13</b>	<b>Package mechanical data .....</b>	<b>47</b>
<b>14</b>	<b>Revision history .....</b>	<b>49</b>

## List of figures

Figure 1.	Simplified application schematic . . . . .	6
Figure 2.	Pin connection (through top view) . . . . .	7
Figure 3.	Efficiency vs load OUT1 = 5 V, TON = VCC. . . . .	15
Figure 4.	Efficiency vs load OUT2 = 3.3 V, TON = VCC . . . . .	15
Figure 5.	Efficiency vs load OUT1 = 1.5 V, TON = VCC . . . . .	15
Figure 6.	Efficiency vs load OUT2 = 1.05 V, TON = VCC . . . . .	15
Figure 7.	Load regulation OUT1 = 5 V, TON = VCC. . . . .	16
Figure 8.	Load regulation OUT2 = 3.3 V, TON = VCC . . . . .	16
Figure 9.	Load regulation OUT1 = 1.5 V, TON = VCC. . . . .	16
Figure 10.	Load regulation OUT2 = 1.05 V, TON = VCC. . . . .	16
Figure 11.	Switching frequency vs load OUT1 = 5 V, TON = VCC . . . . .	16
Figure 12.	Switching frequency vs load OUT2 = 3.3 V, TON = VCC. . . . .	16
Figure 13.	Section 1 line regulation OUT1 = 5 V, TON = VCC . . . . .	17
Figure 14.	Section 2 line regulation OUT2 = 3.3 V, TON = VCC . . . . .	17
Figure 15.	Section 1 line regulation OUT1 = 1,5 V, TON = VCC . . . . .	17
Figure 16.	Section 2 line regulation OUT2 = 1,05 V, TON = VCC . . . . .	17
Figure 17.	Stand-by mode input battery current vs input voltage . . . . .	17
Figure 18.	Shut-down mode input battery current vs input voltage . . . . .	17
Figure 19.	PWM no load input currents vs input voltage . . . . .	18
Figure 20.	SKIP no load input currents vs input voltage . . . . .	18
Figure 21.	NA SKIP no load input currents vs input voltage . . . . .	18
Figure 22.	VREF3 load regulation . . . . .	18
Figure 23.	VREF2 load regulation . . . . .	18
Figure 24.	LDO = 3,3 V load regulation . . . . .	18
Figure 25.	LDO = 5 V load regulation . . . . .	19
Figure 26.	OUT1 soft-start no load . . . . .	19
Figure 27.	OUT2 soft-start no load . . . . .	19
Figure 28.	OUT1 soft-start 8 A constant current load . . . . .	20
Figure 29.	OUT2 soft-start loaded 8 A constant current load . . . . .	20
Figure 30.	OUT1 soft-end, no load . . . . .	20
Figure 31.	OUT2 soft-end, no load . . . . .	20
Figure 32.	OUT1 soft-start, EN2 = VREF2 no loads applied . . . . .	20
Figure 33.	OUT2 soft-start, EN1=VREF2 no loads applied . . . . .	20
Figure 34.	soft-end, EN2 = VREF2 no loads applied. . . . .	21
Figure 35.	soft-end, EN1=VREF2 no loads applied. . . . .	21
Figure 36.	Load transient 0-5 A 2 A/ $\mu$ s OUT1 = 5 V PWM mode . . . . .	21
Figure 37.	Load transient 0-5 A 2 A/ $\mu$ s OUT1 = 5 V SKIP mode . . . . .	21
Figure 38.	Load transient 0-5 A 2 A/ $\mu$ s OUT1 = 1,5 V PWM mode . . . . .	21
Figure 39.	Load transient 0-5 A 2 A/ $\mu$ s OUT1 = 1,5 V SKIP mode. . . . .	21
Figure 40.	Load transient 0-5 A 2 A/ $\mu$ s OUT2 = 3.3 V PWM mode . . . . .	22
Figure 41.	Load transient 0-5 A 2 A/ $\mu$ s OUT2 = 3.3 V SKIP mode . . . . .	22
Figure 42.	Load transient 0-5 A 2 A/ $\mu$ s OUT2 = 1,05 V PWM mode . . . . .	22
Figure 43.	Load transient 0-5 A 2 A/ $\mu$ s OUT2 = 1,05 V SKIP mode. . . . .	22
Figure 44.	Functional block diagram . . . . .	23
Figure 45.	Resistor divider to configure the output voltage . . . . .	25
Figure 46.	Constant on time block diagram . . . . .	27
Figure 47.	Inductor current and output voltage in PWM mode . . . . .	28
Figure 48.	Inductor current and output voltage in SKIP mode . . . . .	29

---

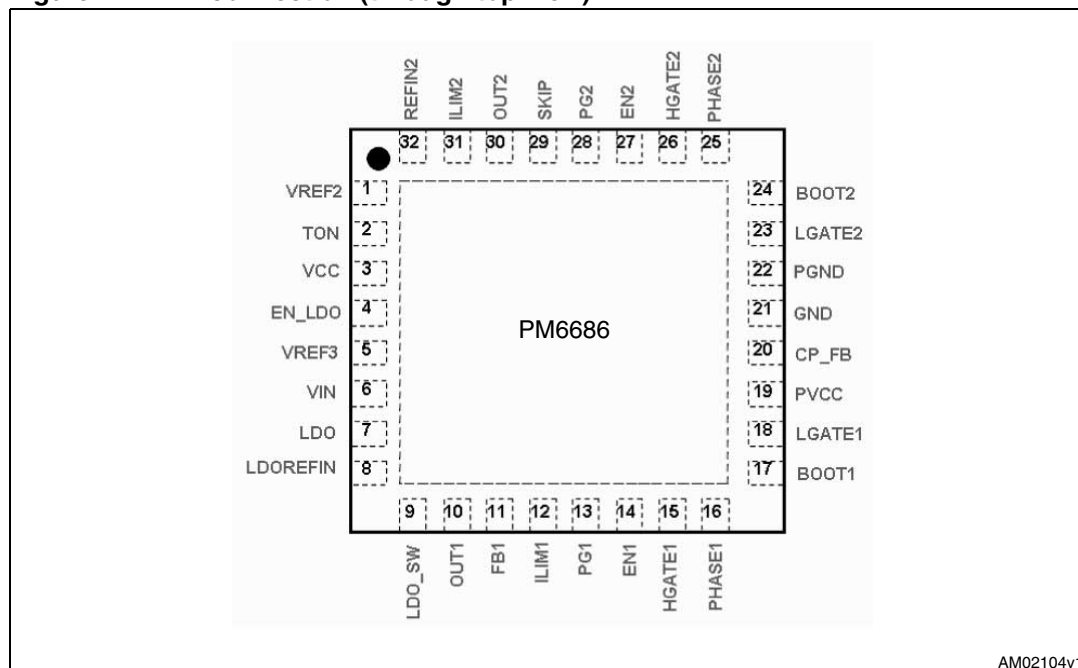
Figure 49.	Inductor current and output voltage in NA SKIP mode . . . . .	30
Figure 50.	Internal supply diagram . . . . .	31
Figure 51.	Current waveforms in current limit conditions. . . . .	31
Figure 52.	Current limit circuit block diagram. . . . .	32
Figure 53.	VOUT2 behavior if EN2 is connected to VREF2 . . . . .	33
Figure 54.	Charge pump application circuit . . . . .	36
Figure 55.	VIN pin filter . . . . .	43
Figure 56.	VCC and PVCC filters. . . . .	43
Figure 57.	Bootstrap circuit . . . . .	44
Figure 58.	Current paths, ground connection and driver traces layout . . . . .	46
Figure 59.	Package dimensions. . . . .	48



## 2 Pin settings

### 2.1 Connections

Figure 2. Pin connection (through top view)



### 2.2 Pin descriptions

Table 2. Pin descriptions

N°	Pin	Function
1	VREF2	Internal 2 V high accuracy voltage reference. It can deliver 50 $\mu$ A. Loading VREF2 can affect FB and output accuracy. Bypass to GND with a 100 nF capacitor.
2	TON	Frequency selection pin. It provides a selectable switching frequency, allowing three different values of switching frequencies for the switching sections.
3	VCC	Controller supply voltage input. Bypass to GND with a 1 $\mu$ F capacitor.
4	EN_LDO	Enable input for the linear regulator. The LDO is enabled if EN_LDO is > 1.6 V and is disabled if EN_LDO < 1 V.
5	VREF3	Internal 3.3 V high accuracy voltage reference. It can deliver 5 mA if bypassed to GND with a 10 nF capacitor. If not used, it can be left floating.
6	VIN	Device supply voltage pin. VIN is used in the on-time generators of the two switching controllers. VIN is also used to power the linear regulator when the switchover function is not active. Connect VIN to the battery input and bypass with a 1 $\mu$ F capacitor.

Table 2. Pin descriptions (continued)

N°	Pin	Function
7	LDO	Linear regulator output. It can provide up to 100 mA peak current. The LDO regulates at 5 V if LDOREFIN is connected to GND. When the LDO is set at 5 V and LDO_SW is within 5 V switchover threshold, the internal regulator shuts down and the LDO output pin is connected to LDO_SW through a 0.8 $\Omega$ switch. The LDO regulates at 3.3 V if LDOREFIN is connected to VCC. When the LDO is set at 3.3 V and LDO_SW is within 3.3 V switchover threshold, the internal regulator shuts down and the LDO output pin is connected to LDO_SW through a 1.1 $\Omega$ switch. Bypass LDO output to GND with a minimum of 4.7 $\mu$ F ceramic capacitor.
8	LDOREFIN	Feedback of the adjustable linear regulator. Connect LDOREFIN to GND for fixed 5 V operation. Connect LDOREFIN to VCC for fixed 3.3 V operation. LDOREFIN can be used to program LDO output voltage from 0.7 V to 4.5 V: LDO output is two times the voltage of LDOREFIN. The switchover function is disabled in adjustable mode.
9	LDO_SW	Source of the switchover connection. LDO_SW is the switchover source voltage for the LDO when LDOREFIN is connected to GND or VCC. Connect LDO_SW to 5 V if LDOREFIN is tied to GND. Connect LDO_SW to 3.3 V if LDOREFIN is tied to VCC.
10	OUT1	Output voltage sense for the switching section 1. This pin must be directly connected to the output voltage of the switching section. It provides also the feedback for the switching section 1 when FB1 is tied to GND/VCC.
11	FB1	Feedback input for the switching section 1: <ul style="list-style-type: none"> <li>– If this pin is connected to GND, OUT1 operates at 5 V</li> <li>– If this pin is connected to VCC, OUT1 operates at 1.5 V</li> <li>– This pin is connected to a resistive voltage-divider from OUT1 to GND to adjust the output voltage from 0.7 V to 5.5 V.</li> </ul>
12	ILIM1	Positive current sense input for the switching section 1. It is possible to set a threshold voltage that is compared with 1/10 <sup>th</sup> of the GND-PHASE1 drop during the off time.
13	PG1	Power Good output signal for the section 1. This pin is an open drain output and it is pulled down when the output of the switching section 1 is out of +/- 10% of its nominal value.
14	EN1	Enable input for the switching section 1. <ul style="list-style-type: none"> <li>– If EN1 &lt; 0.8 V the switching section OUT1 is turned off and all faults are cleared.</li> <li>– If EN1 &gt; 2.4 V the switching section OUT1 is turned on.</li> <li>– If EN1 is connected to VREF2, the switching section OUT1 turns on after the switching section OUT2 reaches regulation.</li> </ul>
15	HGATE1	High-side gate driver output for section 1.
16	PHASE1	Switch node connection and return path for the high-side driver for the section 1. It is also used as positive and negative current sense input.
17	BOOT1	Bootstrap capacitor connection for the switching section 1. It supplies the high-side gate driver.
18	LGATE1	Low-side gate driver output for the section 1.
19	PVCC	5 V low-side gate drivers supply voltage input. Bypass to PGND with a 1 $\mu$ F capacitor.



Table 2. Pin descriptions (continued)

N°	Pin	Function
20	CP_FB	The CP_FB is used to monitor the optional external 14 V charge pump. Connect a resistive voltage-divider from 14 V charge pump output to GND. If CP_FB drops below the threshold voltage, the device performs a no audible skip cycle. This charges the charge pump output (driven by LGATE1). Leave CP_FB floating if the charge pump feedback is not needed.
21	GND	Signal ground reference for internal logic circuitry and LDO. It must be connected to the signal ground plan of the power supply and to the exposed pad. The signal ground plan and the power ground plan must be connected together in one point near the PGND pin.
22	PGND	Power ground. This pin must be connected to the power ground plan of the power supply.
23	LGATE2	Low-side gate driver output for the section 2.
24	BOOT2	Bootstrap capacitor connection for the switching section 2. It supplies the high-side gate driver.
25	PHASE2	Switch node connection and return path for the high-side driver for the section 2. It is also used as positive and negative current sense input.
26	HGATE2	High-side gate driver output for section 2.
27	EN2	Enable input for the switching section 2. <ul style="list-style-type: none"> <li>– If EN2 &lt; 0.8 V the switching section OUT2 is turned off and all faults are cleared.</li> <li>– If EN2 &gt; 2.4 V the switching section OUT2 is turned on.</li> </ul> If EN2 is connected to VREF2, the switching section OUT2 turns on after the switching section OUT1 reaches regulation.
28	PG2	Power Good output signal for the section 2. This pin is an open drain output and It is pulled down when the output of the switching section 2 is out of + 14% / - 10% of its nominal value.
29	SKIP	Pulse skipping mode control input. <ul style="list-style-type: none"> <li>– If the pin is connected to VCC the PWM mode is enabled.</li> <li>– If the pin is connected to GND, the pulse skip mode is enabled.</li> <li>– If the pin is connected to VREF2 (or floating) the pulse skip mode is enabled but and the switching frequency is kept higher than 33 kHz (No-audible pulse skip mode).</li> </ul>
30	OUT2	Output voltage sense for the switching section 2. This pin must be directly connected to the output voltage of the switching section. It provides also the feedback for the switching section 2 when REFIN2 is tied to VREF3/VCC.
31	ILIM2	Positive current sense input for the switching section 2. It is possible to set a threshold voltage that is compared with 1/10 <sup>th</sup> of the GND-PHASE2 drop during the off time.
32	REFIN2	Feedback input for the switching section 2: <ul style="list-style-type: none"> <li>– If this pin is connected to VCC, OUT2 operates at 3.3 V</li> <li>– If this pin is connected to VREF3, OUT2 operates at 1.05 V</li> <li>– If this pin is connected to an external reference from 0.7 V to 2.5 V, OUT2 works in tracking with this reference. Bypass REFIN2 to GND with a 100 nF capacitor.</li> </ul>

## 3 Electrical data

### 3.1 Maximum rating

**Table 3. Absolute maximum ratings**

Parameter	Value	Unit
VIN to PGND	-0.3 to 38	V
PHASEx to PGND	-0.3 to 38	V
BOOTx to PHASEx	-0.3 to 6	V
PVCC to PGND	-0.3 to 6	V
HGATEx to PHASEx	-0.3 to BOOTx +0.3	V
LGATEx, CP_FB to PGND	-0.3 to PVCC +0.3	V
VCC, ENx, SKIP, PGx, LDO, REFIN2, OUTx, VREF3, LDOREFIN, LDO_SW, TON to GND	-0.3 to 6	V
FB1, ILIMx to GND	-0.3 to VCC+0.3	V
EN_LDO to GND	-0.3 to 7	V
VREF2 to GND	-0.3 to VREF3+0.3	V
PGND to GND	-0.3 to +0.3	V
Power dissipation at $T_A = 25\text{ °C}$	2	W
Maximum withstanding voltage range test condition: CDF-AEC-Q100-002- "human body model" acceptance criteria: "normal performance"	±1250	V

### 3.2 Thermal data

**Table 4. Thermal data**

Symbol	Parameter	Value	Unit
$R_{thJA}$	Thermal resistance junction to ambient	35	°C/W
$T_J$	Junction operating temperature range	-40 to 125	°C
$T_{STG}$	Storage temperature range	-50 to 150	°C
$T_A$	Operating ambient temperature range	-40 to 85	°C

## 4 Recommended operating conditions

**Table 5. Recommended operating conditions**

Symbol	Parameter	Value			Unit
		Min	Typ	Max	
VIN	Input voltage range, LDO = 5 V in regulation	5.5	-	28	V
VCC	VCC operative voltage range	4.5	-	5.5	V
REFIN2	REFIN2 voltage range with OUT2 in adjustable mode, VIN = 5.5 V to 28 V	0.7	-	2.5	V
OUT1	OUT1 output voltage range	0.70	-	5.50	V
ILIM	ILIM voltage range	0.2	-	2	V
LDOREFIN	LDOREFIN setting with LDO = 2 x LDOREFIN (adjustable mode)	0.35	-	2.25	V
LDO DC output current (switchover function enabled)	VIN = 5.5 V to 28 V, LDO_SW = 5 V, LDOREFIN = GND		-	200	mA
	VIN = 5.5 V to 28 V, LDO_SW = 3.3 V, LDOREFIN = VCC		-	100	mA
LDO DC output current (switchover function disabled)	VIN = 5.5 V to 28 V, LDO_SW = 0 V, LDOREFIN = GND, VCC		-	100	mA

## 5 Electrical characteristics

VIN = 12 V, no load on LDO, OUT1, OUT2, VREF3, and VREF2. EN2 = EN1 = VCC, LDO\_SW = 5 V, PVCC = 5 V, EN\_LDO = 5 V, T<sub>J</sub> = 25 °C unless otherwise specified)

**Table 6. Electrical characteristics**

Symbol	Parameter	Test condition	Min	Typ	Max	Unit	
<b>Switching controller output accuracy</b>							
OUT2	Output voltage	VIN = 5.5 V to 28 V, REFIN2 = VCC, SKIP = VCC	3.25	3.330	3.397	V	
		VIN = 5.5 V to 28 V, REFIN2 = VREF3, SKIP = VCC	1.038	1.05	1.062	V	
OUT1	Output voltage	VIN = 5.5 V to 28 V, FB1 = VCC, SKIP = VCC	1.482	1.500	1.518	V	
		VIN = 5.5 V to 28 V, FB1 = GND, SKIP = VCC	4.975	5.050	5.125	V	
FB1	Feedback accuracy with OUT1 in adjustable mode	VIN = 5.5 V to 28 V, SKIP = VCC	0.693	0.700	0.707	V	
REFIN2	Accuracy referred to REFIN2	REFIN2 = 0.7 V to 2.5 V, SKIP = VCC	-1		1	%	
<b>Current limit and zero crossing comparator</b>							
ILIM	ILIM bias current	T <sub>A</sub> = +25 °C.	4.5	5	5.5	µA	
	Positive current limit threshold	Adjustable, VILIM = 0.5 V, GND-PHASE	35	50	65	mV	
		Adjustable, VILIM = 1 V or VCC, GND-PHASE	85	100	115	mV	
		Adjustable, VILIM = 2 V, GND-PHASE	180	200	220	mV	
	Zero crossing current threshold	SKIP = GND, VREF2, or OPEN, GND-PHASE	-1		+11	mV	
<b>Switching frequency</b>							
	On-time pulse width	OUT1 = 5.125 V	TON = GND or VREF2	0.908	1.068	1.228	µs
			TON = VCC	1.815	2.135	2.455	
		OUT2 = 3.368 V	TON = GND	0.477	0.561	0.655	
			TON = VCC or VREF2	0.796	0.936	1.076	
	Minimum Off-time			350	472		
	No-audible skip mode operating frequency	SKIP = VREF2(or OPEN)	25	33		kHz	
<b>Soft-start and soft-end</b>							
	Soft-start ramp time		2		4	ms	

Table 6. Electrical characteristics (continued)

Symbol	Parameter	Test condition	Min	Typ	Max	Unit
<b>Linear regulator and reference</b>						
LDO	LDO output voltage	LDO_SW = GND, 5.5 V < VIN < 28 V, LDOREFIN < 0.3 V, 0 < ILDO < 100 mA	4.925	5.000	5.075	V
		LDO_SW = GND, 5.5 V < VIN < 28 V, LDOREFIN = VREF3, 0 < ILDO < 100 mA	3.250	3.300	3.350	V
	LDO accuracy in adjustable mode	VIN = 5.5 V to 28 V, LDOREFIN = 0.35 V to 2.25 V, no load	-2.5		+2.5	%
	LDO short circuit current (linear regulator enabled)	LDO = 4.3 V, LDO_SW = GND	260	320	380	mA
LDO_SW	LDO_SW switch on threshold	LDO = 5 V, rising edge of LDO_SW, LDOREFIN = GND	4.64	4.75	4.84	V
LDO_SW	LDO_SW hysteresis	LDO = 5 V, falling edge of LDO_SW, LDOREFIN = GND		200	400	mV
	LDO_SW switch resistance	LDO = 5 V, rising edge of LDO_SW, LDOREFIN = GND, output current = 200 mA		0.81	1.275	Ω
VREF3	VREF3 output voltage	No load	3.235	3.300	3.365	V
	VREF3 current limit	VREF3 = GND		22	30	mA
VREF2	VREF2 output voltage	No load	1.980	2.000	2.02	V
	VREF2 load regulation	0 < Load < 50 μA		6		mV
	VREF2 sink current	VREF2 > 2.030 V	10			μA
	VIN shutdown current	EN1 and EN2 low, EN_LDO low		49	70	μA
	VIN standby current	EN1 and EN2 low, EN_LDO high, LDOREFIN = GND		132	180	μA
	Operating power consumption (VCC and VIN pins consumption)	Switching regulators on, FB1 = SKIP = GND, REFIN2 = VCC, LDOREFIN = GND, OUT1 = LDO_SW = 5.3V, OUT2 = 3.5 V		4,3	6,5	mW
<b>Fault management</b>						
	PVCC UVLO threshold	Rising edge of PVCC		4.33		V
		Falling edge of PVCC		4		V
	Overvoltage trip threshold	Referred to FB1 nominal regulation point		+11		%
		Referred to REFIN2 nominal regulation point. worst case:REFIN2 = 0.7 V		+14		%
	PG threshold	Lower threshold	-13	-10	-7	%
	PG low voltage	ISink = 4 mA	159	235	405	mV
	PG leakage current	PG = 5 V			1	μA

**Table 6. Electrical characteristics (continued)**

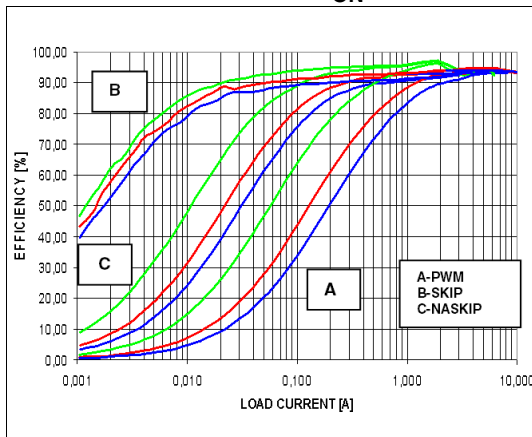
Symbol	Parameter	Test condition	Min	Typ	Max	Unit
	Output undervoltage shutdown threshold	Referred to FB1, REFIN2 nominal regulation point	67	70	73	%
<b>Inputs and outputs</b>						
FB1	FB1 logic level	fixed OUT1 = 5 V			0.528	V
		fixed OUT1 = 1.5 V	4.1			V
REFIN2	REFIN2 logic level	fixed OUT2 = 1.05 V, VCC = 5 V		VREF3		V
		fixed OUT 2= 3.3 V, VCC = 5 V	VCC-0.838			V
LDOREFIN	LDOREFIN logic level	fixed LDO = 5 V			0.4	V
		fixed LDO = 3.3 V	2.43			V
SKIP	SKIP logic level	Pulse skip mode			0.8	V
		No audible skip mode (VREF2 or floating)		VREF2		V
		PWM mode	2.4			V
TON	TON logic level	Low level			0.8	V
		Middle level		VREF2		V
		High level	2.4			V
EN1,2	EN level	Switching regulators off level			0.8	V
		Delay start level		VREF2		V
		Switching regulators on level	2.4			V
EN_LDO	EN_LDO level	Linear regulator off level	0.905	1.00	1.050	V
		Linear regulator on level	1.500	1.6	1.650	V
	Input leakage current	FB1 = 0.7 V	-1		+1	µA
		REFIN2 = 2.5 V		12		
<b>Internal bootstrap diode</b>						
	Diode forward voltage	PVCC = -BOOT, I <sub>diode</sub> = 10 mA		0.2		V
	Diode Leakage current	BOOT= 30 V, PHASE = 28 V, PVCC = 5 V			500	nA
<b>High-side and low-side gate drivers</b>						
	HGATE driver on-resistance	HGATEx high state (pull-up) I <sub>source</sub> = 100 mA		1.8		Ω
		HGATEx low state (pull-down) I <sub>sink</sub> = 100 mA		1.3	1.9	
	LGATE driver on-resistance	LGATEx high state (pull-up) I <sub>source</sub> = 100 mA		1.3		
		LGATEx low state (pull-down) I <sub>sink</sub> = 100 mA		0.6	0.8	

## 6 Typical operating characteristics

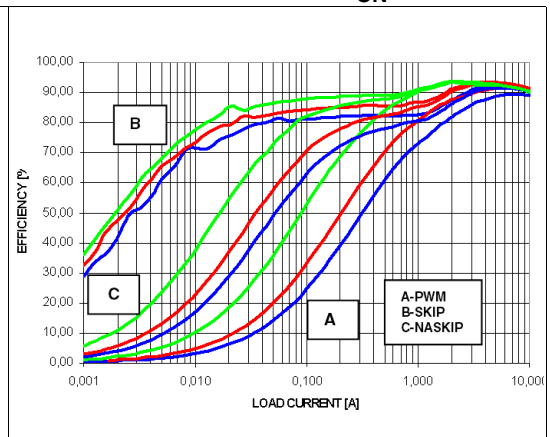
( $T_{ON} = VCC$  (200 / 300 kHz), SKIP = GND (skip mode), LDOREFIN = SGND (LDO = 5 V), LDO\_SW = OUT1, PVCC connected to LDO,  $V_{IN} = 12$  V, EN1-EN2-EN\_LDO are high, no load unless specified). Measures performed on the demonstration kit (PM6686\_SYSTEM and PM6686\_CHIPSET)

Efficiency traces: Green:  $V_{IN} = 7$  V, red:  $V_{IN} = 12$  V, blue:  $V_{IN} = 19$  V.

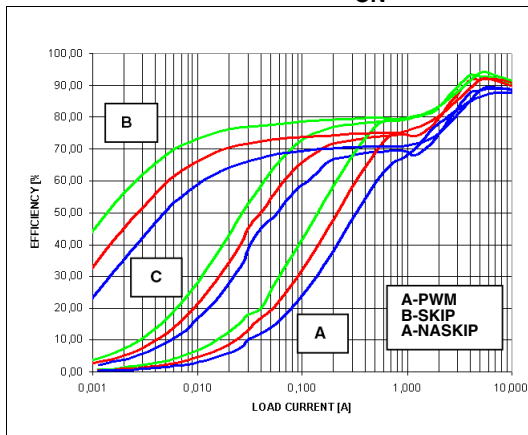
**Figure 3. Efficiency vs load**  
OUT1 = 5 V,  $T_{ON} = VCC$



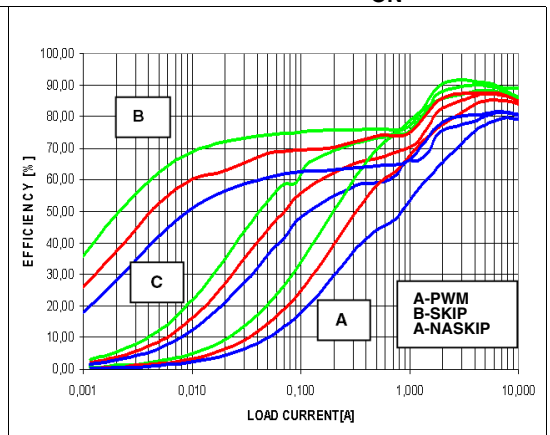
**Figure 4. Efficiency vs load**  
OUT2 = 3.3 V,  $T_{ON} = VCC$



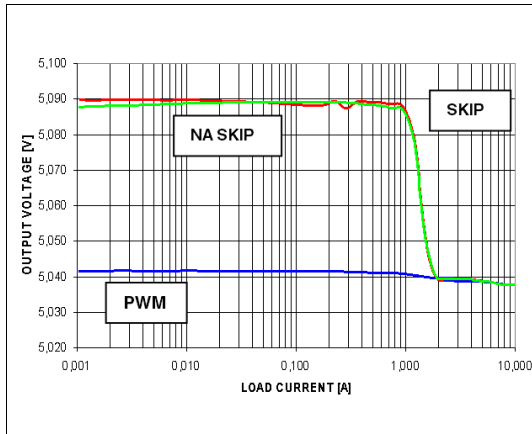
**Figure 5. Efficiency vs load**  
OUT1 = 1.5 V,  $T_{ON} = VCC$



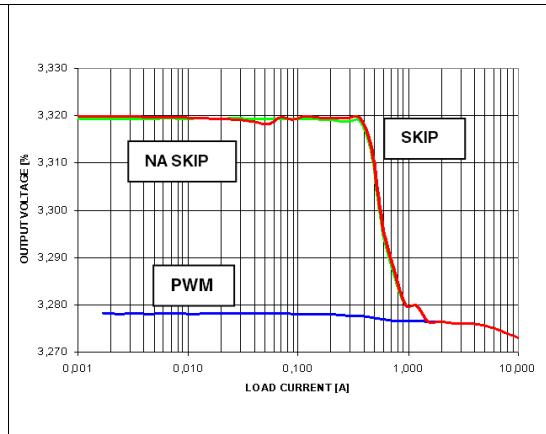
**Figure 6. Efficiency vs load**  
OUT2 = 1.05 V,  $T_{ON} = VCC$



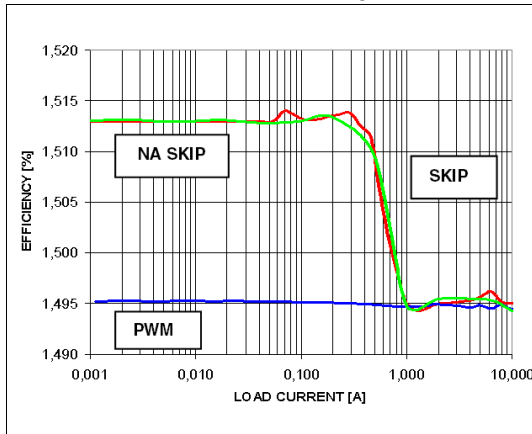
**Figure 7. Load regulation**  
**OUT1 = 5 V,  $T_{ON} = VCC$**



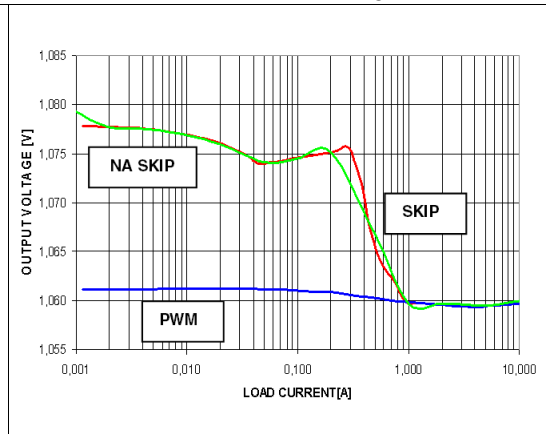
**Figure 8. Load regulation**  
**OUT2 = 3.3 V,  $T_{ON} = VCC$**



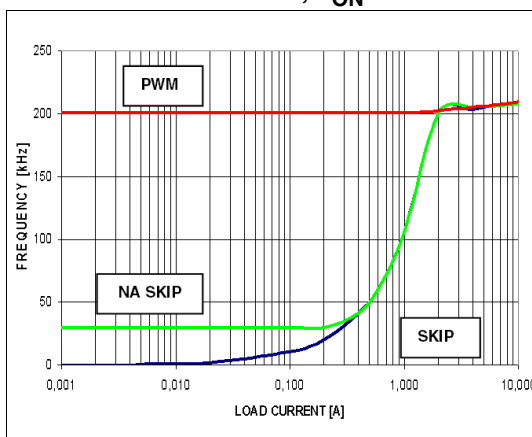
**Figure 9. Load regulation**  
**OUT1 = 1.5 V,  $T_{ON} = VCC$**



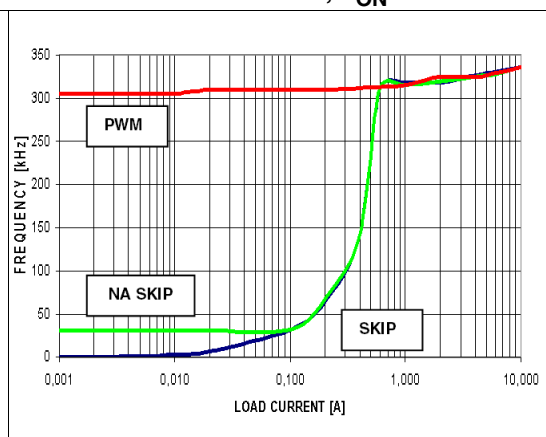
**Figure 10. Load regulation**  
**OUT2 = 1.05 V,  $T_{ON} = VCC$**



**Figure 11. Switching frequency vs load**  
**OUT1 = 5 V,  $T_{ON} = VCC$**

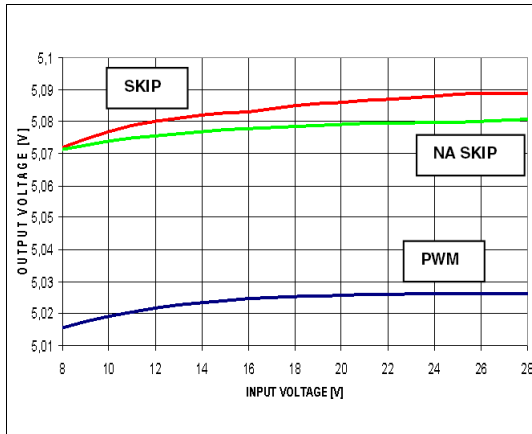


**Figure 12. Switching frequency vs load**  
**OUT2 = 3.3 V,  $T_{ON} = VCC$**

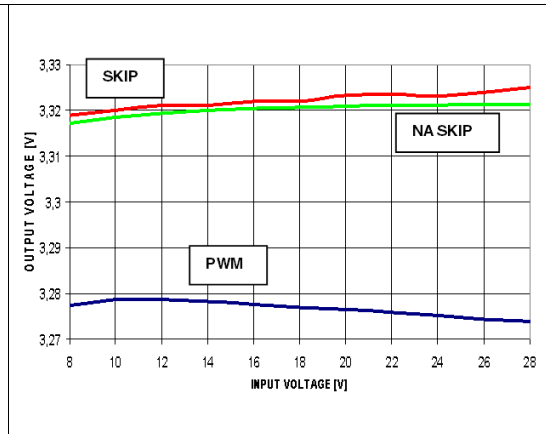




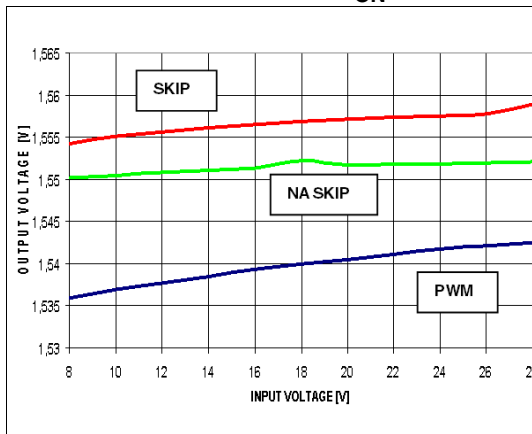
**Figure 13. Section 1 line regulation**  
**OUT1 = 5 V, T<sub>ON</sub> = VCC**



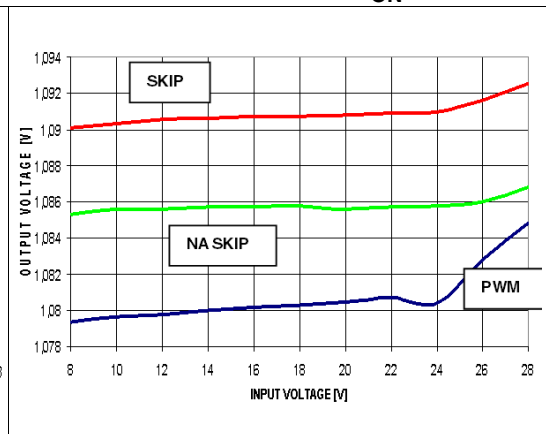
**Figure 14. Section 2 line regulation**  
**OUT2 = 3.3 V, T<sub>ON</sub> = VCC**



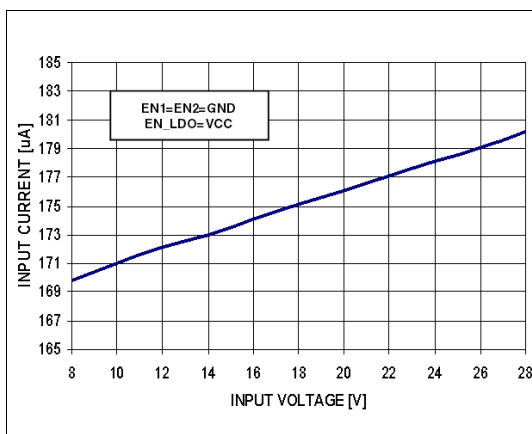
**Figure 15. Section 1 line regulation**  
**OUT1 = 1,5 V, T<sub>ON</sub> = VCC**



**Figure 16. Section 2 line regulation**  
**OUT2 = 1,05 V, T<sub>ON</sub> = VCC**



**Figure 17. Stand-by mode input battery current vs input voltage**



**Figure 18. Shut-down mode input battery current vs input voltage**

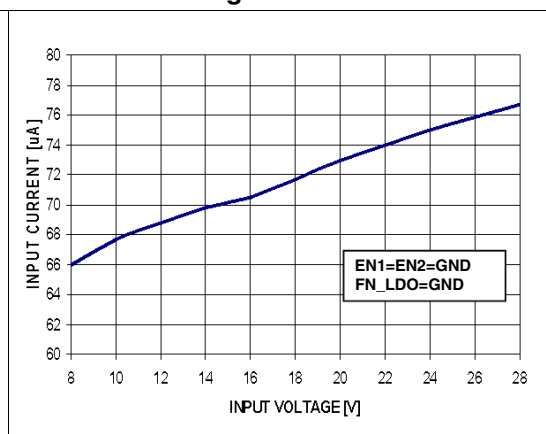


Figure 19. PWM no load input currents vs input voltage

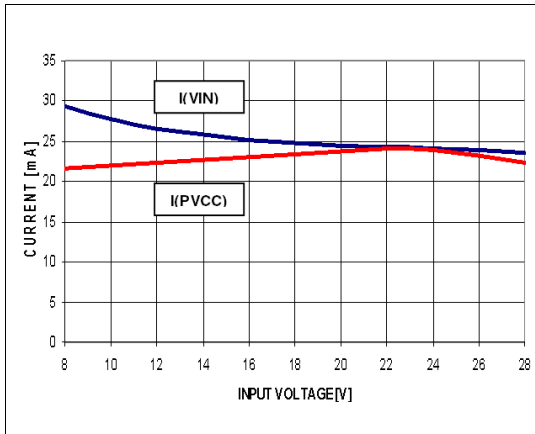


Figure 20. SKIP no load input currents vs input voltage

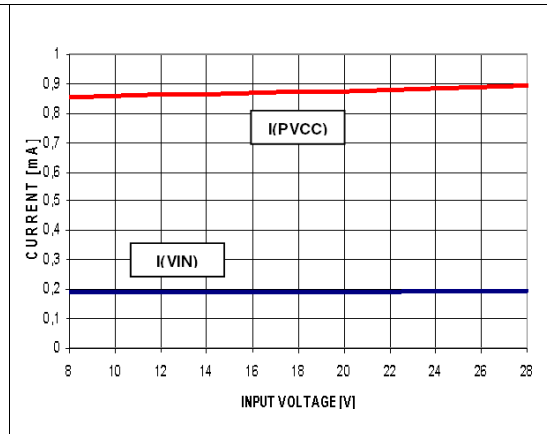


Figure 21. NA SKIP no load input currents vs input voltage

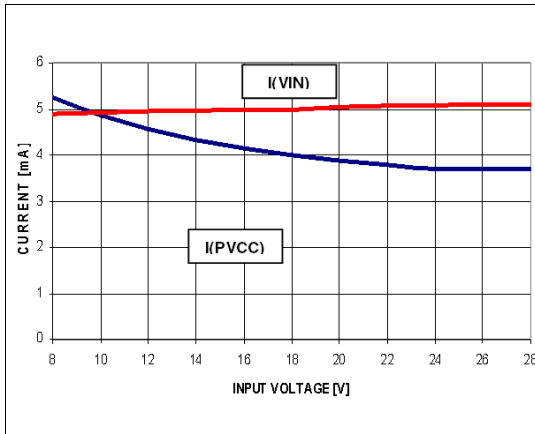


Figure 22. VREF3 load regulation

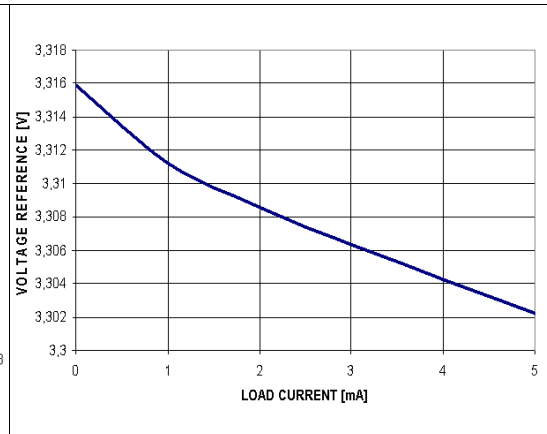


Figure 23. VREF2 load regulation

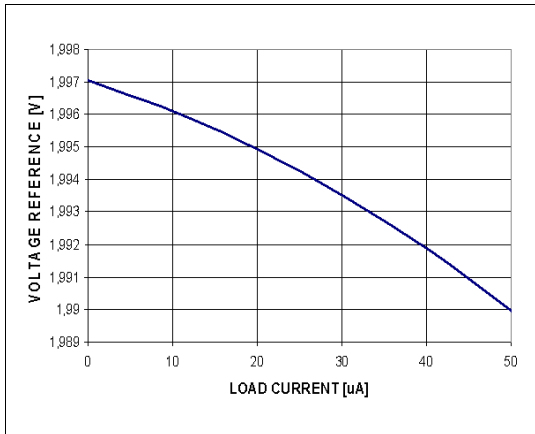


Figure 24. LDO = 3.3 V load regulation

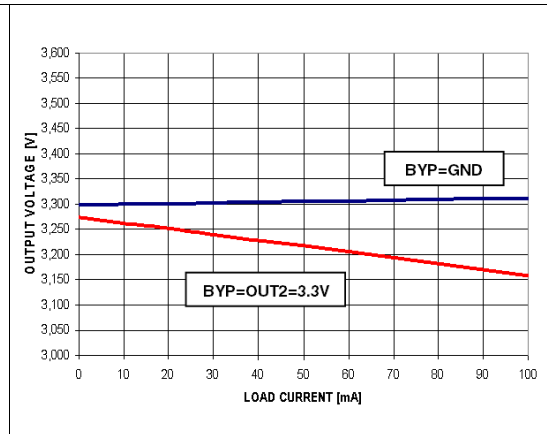
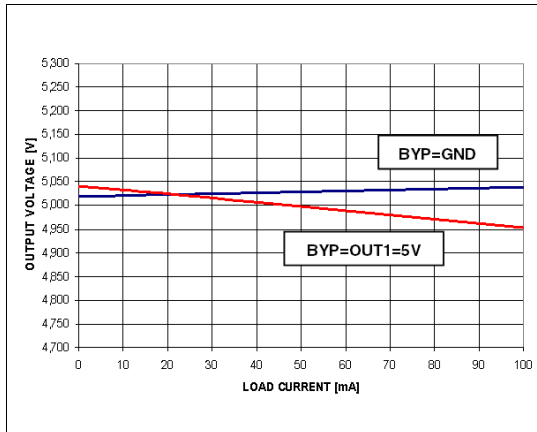


Figure 25. LDO = 5 V load regulation



### 6.1 Screen shots

Typical operating characteristic ( $T_{ON} = VCC$  (200 / 300 kHz), SKIP = GND (skip mode), FB1 = GND (OUT1 = 5 V), REFIN2 = VCC (OUT2 = 3.3 V), LDOREFIN = SGND (LDO = 5 V), CP\_FB = floating, LDO\_SW = OUT1, PVCC connected to LDO, VIN = 12 V, EN1-EN2-EN\_LDO are high, no load unless specified)

Figure 26. OUT1 soft-start no load

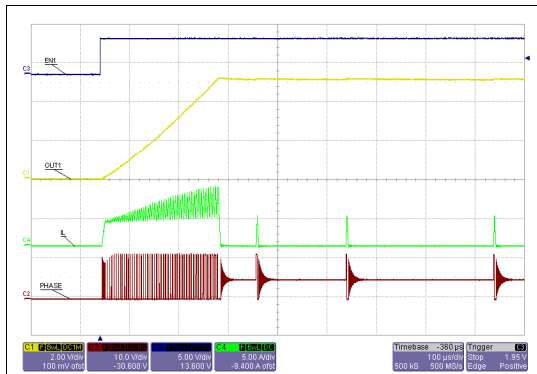


Figure 27. OUT2 soft-start no load

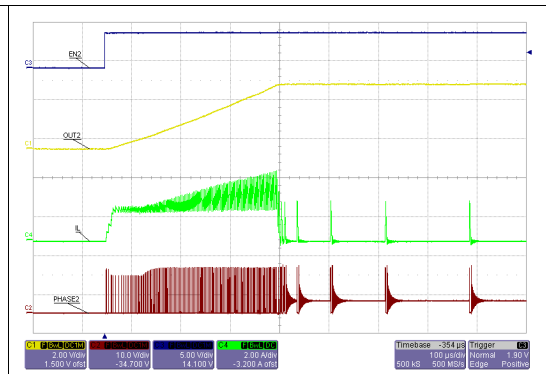


Figure 28. OUT1 soft-start 8 A constant current load

Figure 29. OUT2 soft-start loaded 8 A constant current load

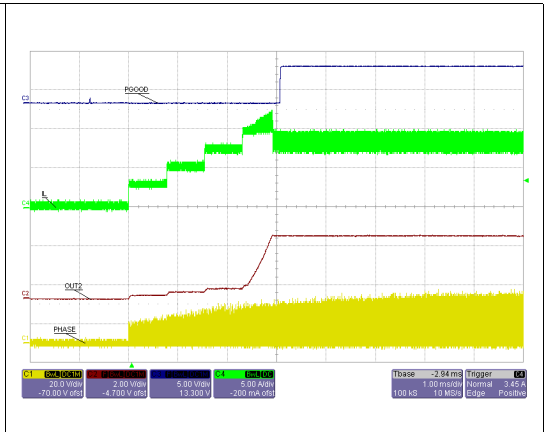
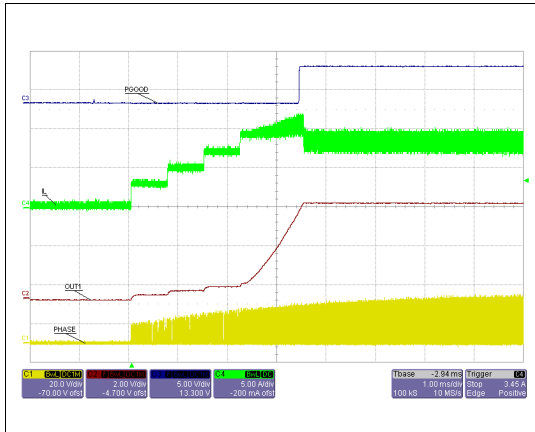


Figure 30. OUT1 soft-end, no load

Figure 31. OUT2 soft-end, no load

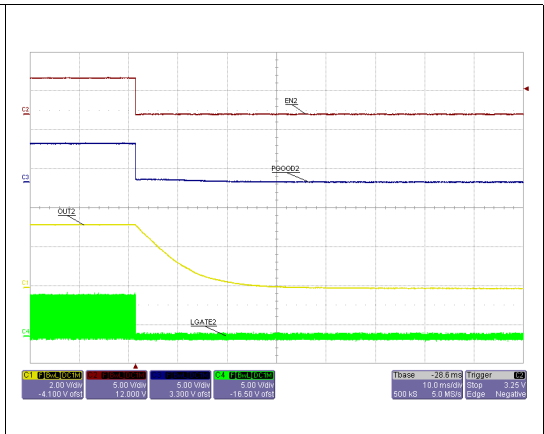
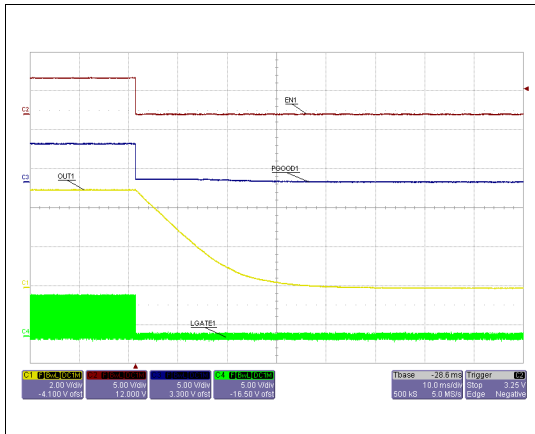
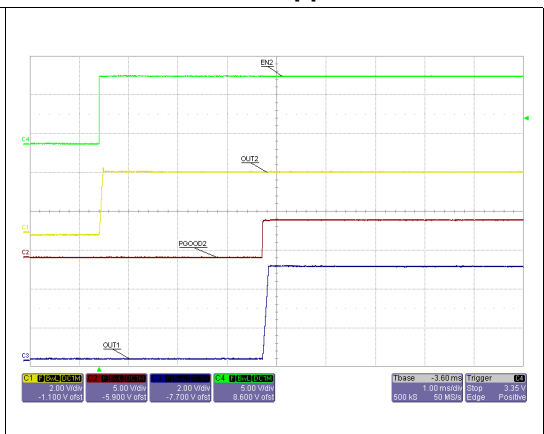
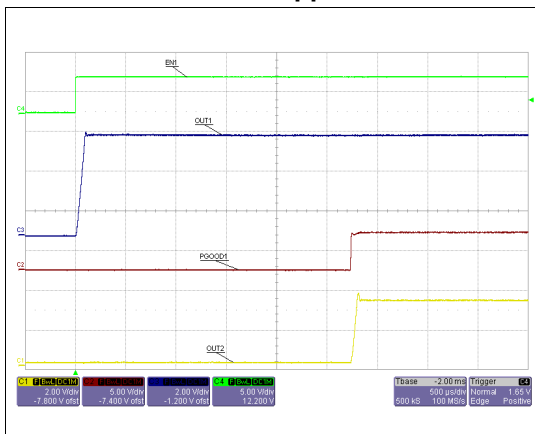
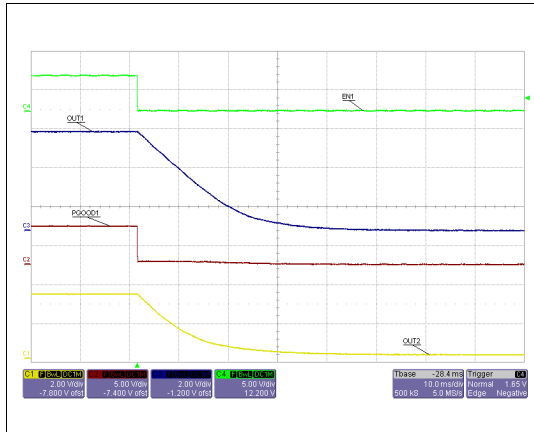


Figure 32. OUT1 soft-start, EN2 = VREF2 no loads applied

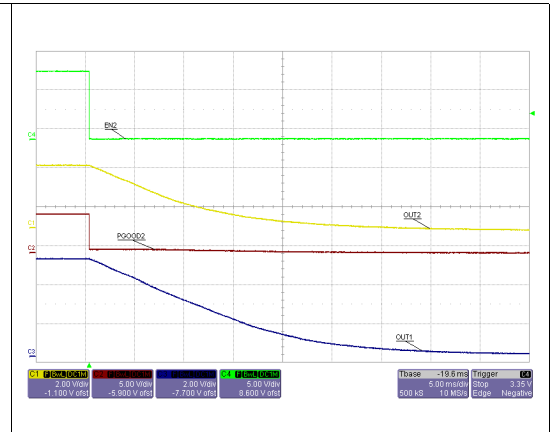
Figure 33. OUT2 soft-start, EN1=VREF2 no loads applied



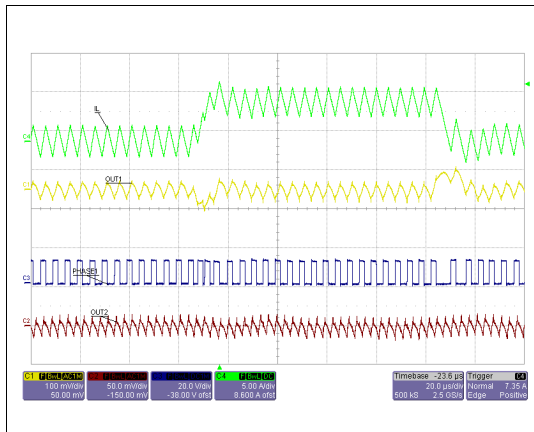
**Figure 34. Soft-end, EN2 = VREF2 no loads applied**



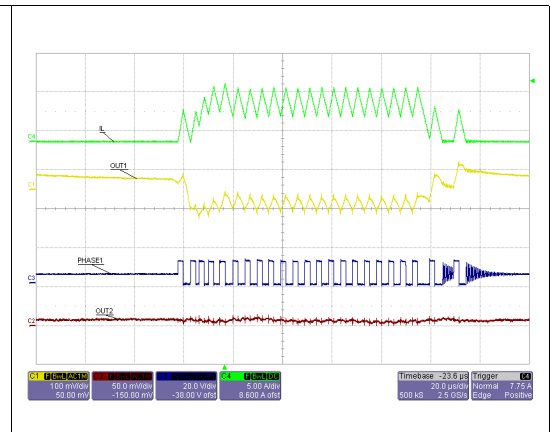
**Figure 35. Soft-end, EN1=VREF2 no loads applied**



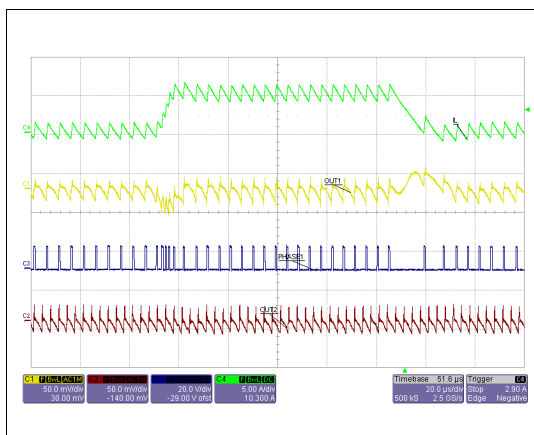
**Figure 36. Load transient 0-5 A 2 A/μs OUT1 = 5 V PWM mode**



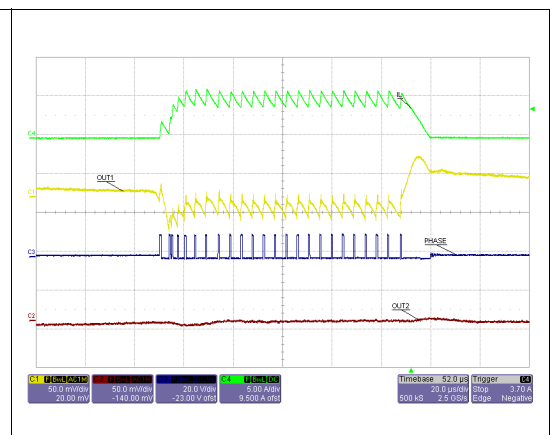
**Figure 37. Load transient 0-5 A 2 A/μs OUT1 = 5 V SKIP mode**



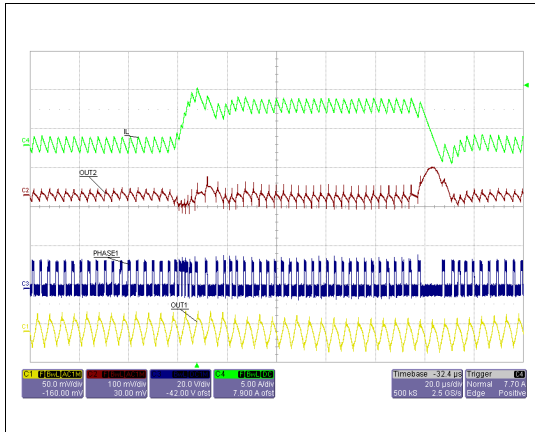
**Figure 38. Load transient 0-5 A 2 A/μs OUT1 = 1.5 V PWM mode**



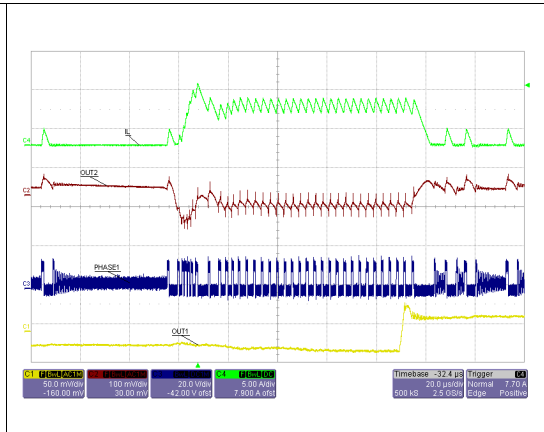
**Figure 39. Load transient 0-5 A 2 A/μs OUT1 = 1.5 V SKIP mode**



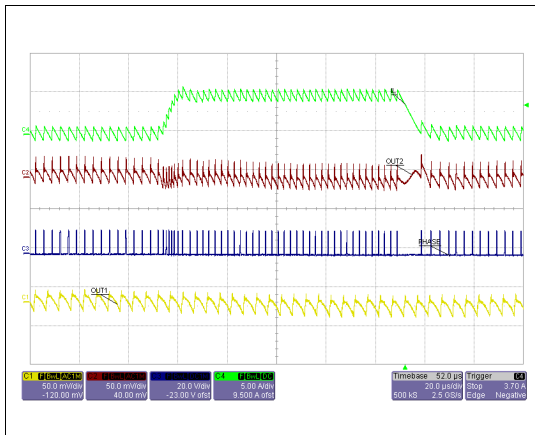
**Figure 40. Load transient 0-5 A 2 A/μs  
OUT2 = 3.3 V PWM mode**



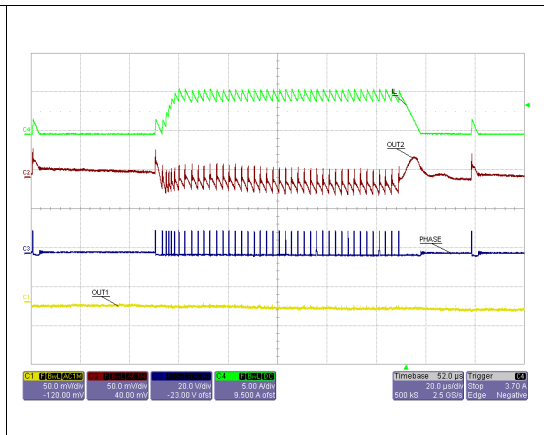
**Figure 41. Load transient 0-5 A 2 A/μs  
OUT2 = 3.3 V SKIP mode**



**Figure 42. Load transient 0-5 A 2 A/μs  
OUT2 = 1.05 V PWM mode**

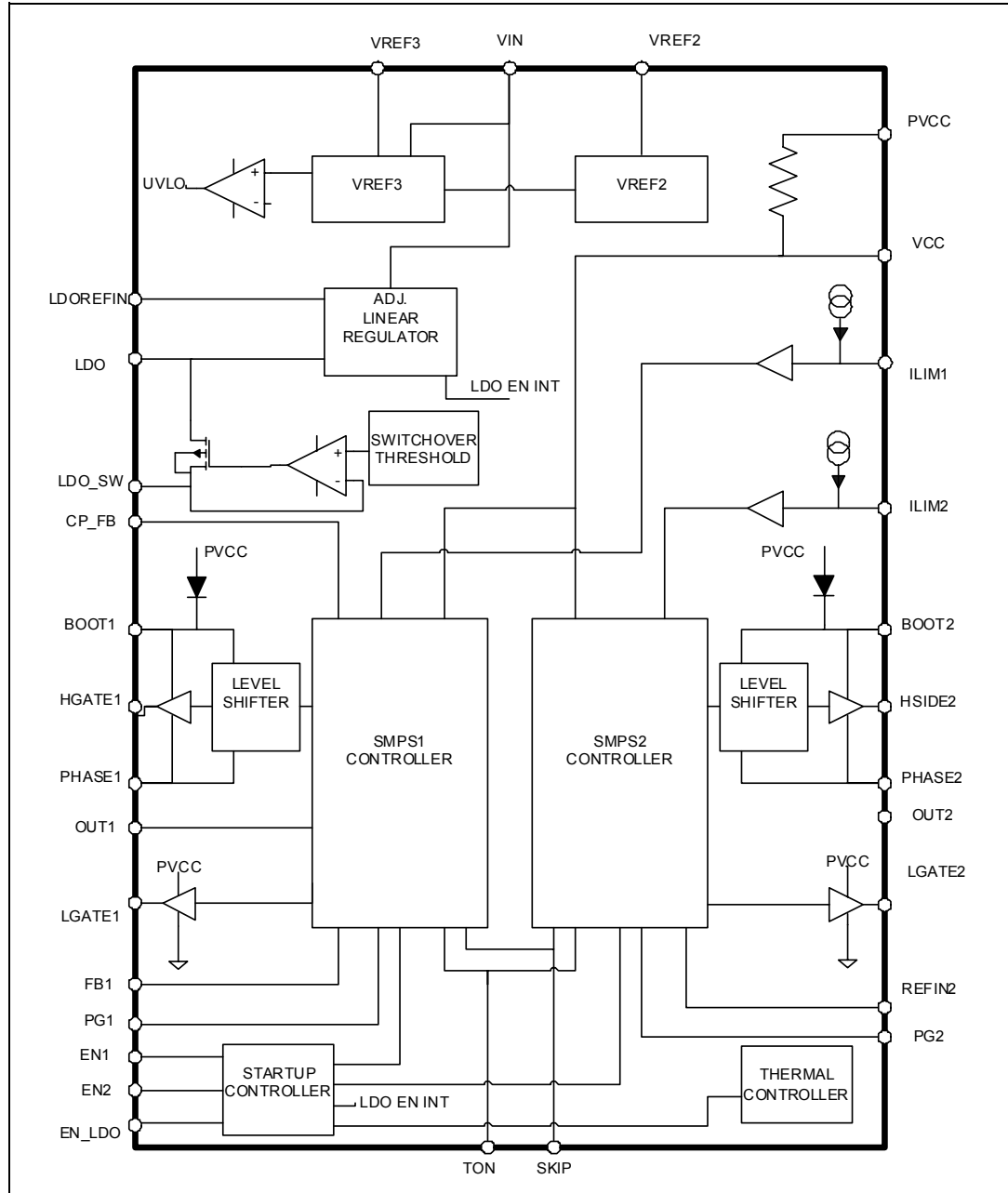


**Figure 43. Load transient 0-5 A 2 A/μs  
OUT2 = 1.05 V SKIP mode**



# 7 Block diagram

Figure 44. Functional block diagram



## 8 Device description

The PM6686 is a dual step down controller dedicated to provide logic voltages for notebook computers. It offers several operating configurations: it combines two synchronous buck controllers, an internal linear regulator (LDO), two voltage references and a charge pump controller.

Each buck controller is based on constant on time (COT) architecture. This type of control offers a very fast load transient response with a minimum external components count.

The two switching sections (SMPS) generate two output voltages OUT1 and OUT2 that regulate adjustable voltages. A fixed output voltage configuration can also be selected, reducing further the external components count because no external resistor divider is needed.

In fixed mode, OUT1 provides 5 V or 1.5 V; in adjustable mode OUT1 can regulate an output voltage between 0.7 V and 5.5 V. In fixed mode, OUT2 provides 3.3 V or 1.05 V, in adjustable mode OUT2 can regulate an output between 0.7 V to 2.5 V by tracking an external reference.

The switching frequencies of both switching controllers can be adjusted to 200 kHz/300 kHz, 400 kHz/300 kHz or 400 kHz/500 kHz respectively. To maximize the efficiency at light loads a pulse skipping mode can be selected. Moreover a pulse skipping mode with a minimum switching frequency of 33 kHz (non audible skip operation mode) can be selected to avoid audible noise issue. The linear regulator can provide a fixed (5 V or 3.3 V) or an adjustable output voltage. In order to reduce the power consumption the internal LDO can be turned off and the LDO output can be supplied with an external voltage applied at LDO\_SW pin (switch-over function).

The PM6686 supplies two voltage references: 3.3 V and 2 V. The charge pump controller can be programmed to regulate a 14 V output. The switching sections and the LDO have independent enable signals. Moreover the switching sections have a selectable power up sequence and a turn off management.

The device is protected against overvoltage, undervoltage and over temperature. Two independent Power Good signals monitor the output voltage range of each switching sections.

### 8.1 Switching sections

#### 8.1.1 Output voltage set up

The switching sections can be configured in several ways.

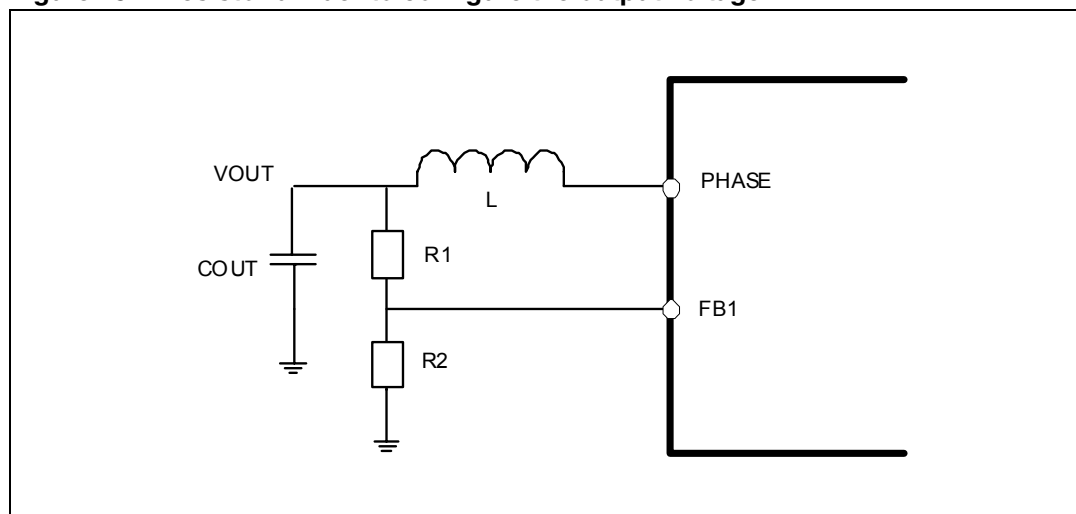
OUT1 output voltage is configured with FB1 pin. If FB1 pin is tied to GND the PM6686 regulates 5 V while if FB1 is connected to VCC the controller set OUT1 at 1.5 V. Using an external resistor divider the output can be adjusted following this equation:

##### Equation 1

$$V_{OUT1} = 0,7V \cdot \left( \frac{R1}{R2} + 1 \right)$$



Figure 45. Resistor divider to configure the output voltage



Where R1, R2 are the resistors of the FB1 pin divider, as shown in Figure 2.

OUT2 output voltage is programmed with REFIN2 pin. Fixed output voltage is selected connecting REFIN2 to VREF3 (OUT2 = 1.05 V) or to VCC (OUT2 = 3.3 V).

When the REFIN2 voltage is between 0.7 V and 2.5 V, OUT2 output voltage tracks REFIN2 voltage. When REFIN2 is lower than 0.5 V the section is turned OFF.

Table 7. Switching output voltages configuration

Output	control pin	Control pin connected to	Operation mode	Output voltage
OUT1	FB1	GND	Fixed	5 V
		VCC	Fixed	1.5 V
		Resistor divider	Adj	$V_{OUT1} = 0.7V \cdot \left(\frac{R1}{R2} + 1\right)$
OUT2	REFIN2	VCC	Fixed	3.3 V
		VREF3	Fixed	1.05 V
		Ext source	Tracking	=REFIN2

### 8.1.2 Constant on time control (COT)

PM6686 implements a pseudo-fixed frequency algorithm using the COT architecture. The two sections are completely independent with separated switching controllers (SMPS).

The COT architecture bases its algorithm on the output ripple derived across the output capacitor's ESR. The controller has an internal on time ( $T_{ON}$ ) generator triggered on the output voltage valley: when  $V_{OUT}$  reaches the regulation value a new  $T_{ON}$  starts. The  $T_{ON}$  duration is given by the following equation:

**Equation 2**

$$T_{ON} = K \cdot \frac{V_{OUT}}{V_{IN}}$$

Where  $T_{ON}$  is the on time duration,  $K$  is a constant,  $V_{OUT}$  is the sensed output voltage and  $V_{IN}$  is the input voltage.

The duty cycle in a buck converter is:

**Equation 3**

$$\frac{T_{ON}}{T_{SW}} = D = \frac{V_{OUT}}{V_{IN}}$$

The switching frequency in continuous current mode (CCM) is:

**Equation 4**

$$f_{SW} = \frac{D}{T_{ON}} = \frac{\frac{V_{OUT}}{V_{IN}}}{K \cdot \frac{V_{OUT}}{V_{IN}}} = \frac{1}{K}$$

The switching frequency is theoretically constant, but in a real application it depends on parasitic voltage drops that occur during the charging path (high-side switch resistance, inductor resistance (DCR)) and discharging path (low-side switch resistance, DCR). As a result the switching frequency increases as a function of the load current. The following table shows the switching frequencies that can be selected through  $T_{ON}$  pin:

**Table 8. Frequency configurations**

TON	SMPS 1		SMPS 2	
	Frequency	K	Frequency	K
VCC	200 kHz	5 $\mu$ s	300 kHz	3.33 $\mu$ s
VREF2 or open	400 kHz	2.5 $\mu$ s	300 kHz	3.33 $\mu$ s
GND	400 kHz	2.5 $\mu$ s	500 kHz	2 $\mu$ s

The COT architecture uses a minimum off-time ( $T_{OFFMIN}$ ) to allow inductor valley current sense on the synchronous switch and to allow the charge of the bootstrap capacitor. A minimum on-time is also introduced to assure the start-up sequence.

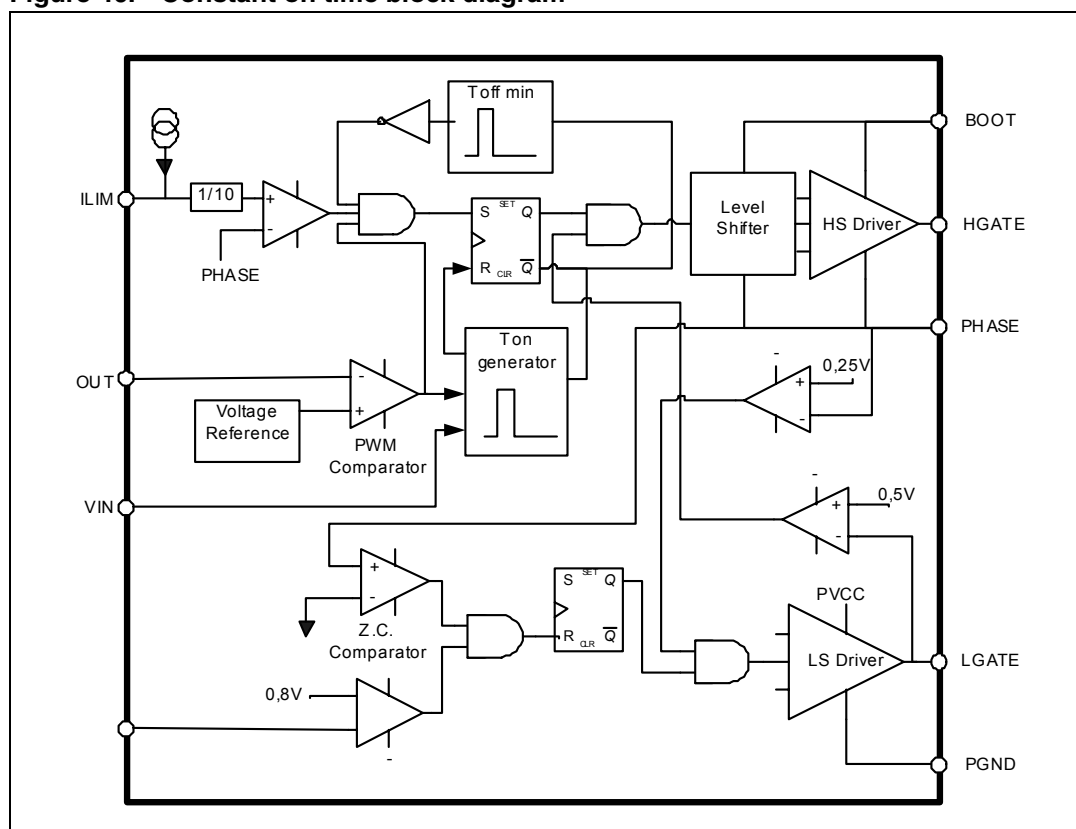
An adaptive anti-cross conduction algorithm avoids current paths between  $V_{IN}$  and GND during switching transition.

The PM6686 has three different operation modes selectable with SKIP pin: forced PWM (PWM), pulse SKIP (SKIP) and non audible pulse SKIP (NA SKIP). The following paragraphs explain in details the different features of these operation modes.

**Table 9. Operative mode configurations**

Control pin	Control pin connected to	Operation mode
SKIP	VCC	PWM
	GND	SKIP
	VREF2 or floating	NA SKIP

**Figure 46. Constant on time block diagram**



### 8.1.3 PWM

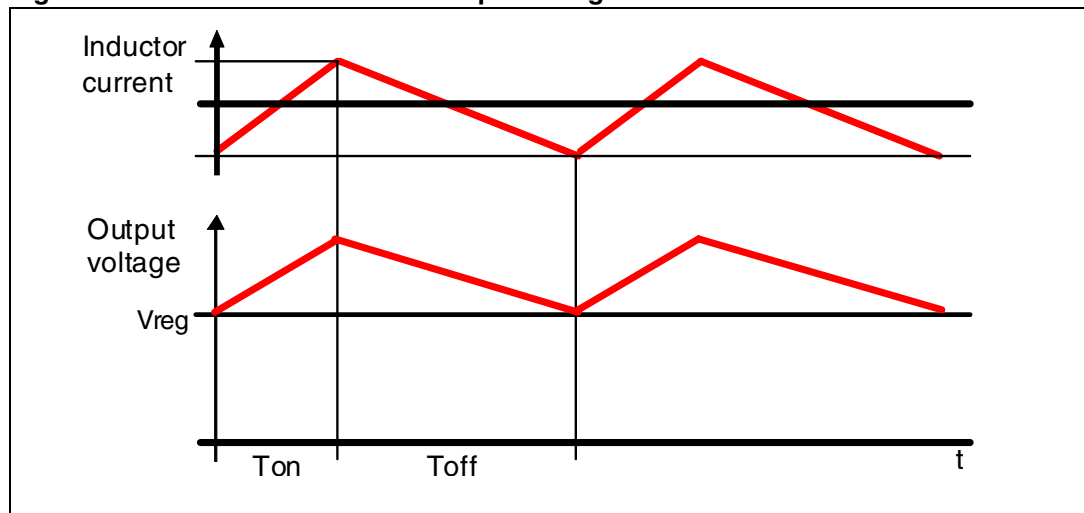
PWM implements the continuous current mode (CCM). During  $T_{ON}$ , the high-side MOSFET is turned on and the inductor current starts increasing. When the  $T_{on}$  is elapsed the high-side MOSFET is turned off and after a dead time during which neither MOSFET conducts, the low-side MOSFET turns on. The inductor current decreases until these three conditions are verified:

- Output voltage reaches the regulation voltage
- Inductor current is below the current limit
- $T_{OFFMIN}$  is elapsed

When these conditions are satisfied a new  $T_{ON}$  starts.

PWM operation mode has a quasi-constant switching frequency, avoiding any audible noise issue and the continuous current mode assures better load transitions despite of a lower efficiency at light loads.

**Figure 47. Inductor current and output voltage in PWM mode**

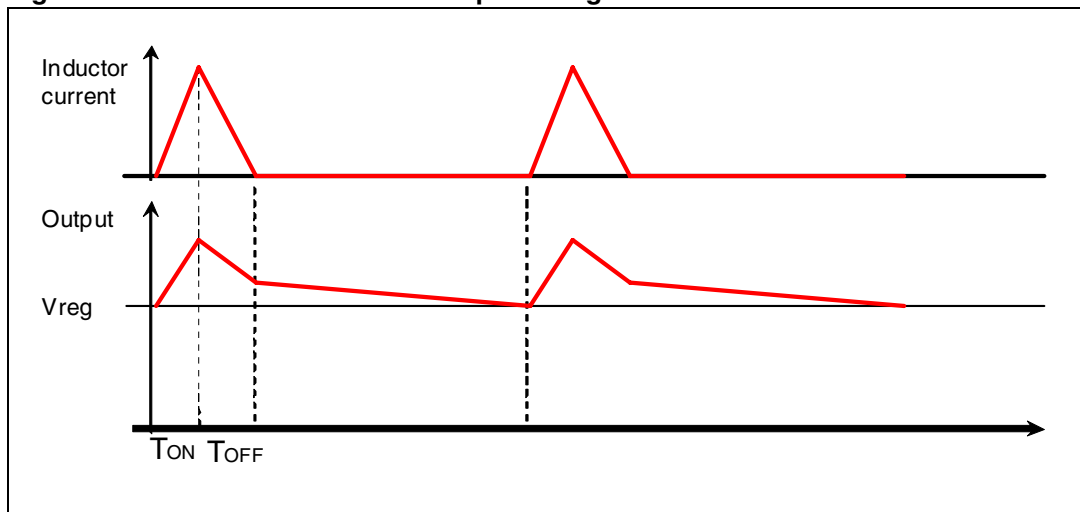


### 8.1.4 SKIP

To improve the efficiency at light load the PM6686 implements pulse skip operation mode. When SKIP pin is tied to GND the inductor current is sensed and if it is equal to zero the synchronous MOSFET is turned off. As a consequence the output capacitor is left floating and the discharge depends only on the current sourced by the load. The new  $T_{ON}$  starts when the output reaches the voltage regulation. As a consequence at light load conditions the switching frequency decreases improving the total efficiency of the converter. Working in discontinuous current mode, the switching and the conduction losses are decreased skipping some cycles.

If the output load is high enough to make the system work in CCM, skip mode is automatically changed in PWM mode.

**Figure 48. Inductor current and output voltage in SKIP mode**

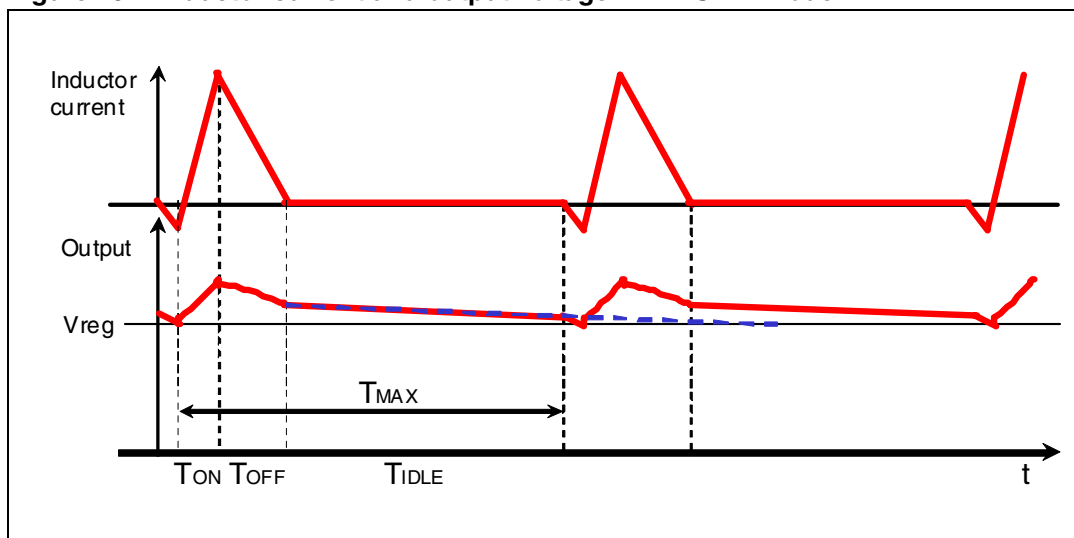


### 8.1.5 Non audible SKIP (NA SKIP)

To avoid audio noise the NA SKIP operation mode can be selected, connecting SKIP pin to VREF2 or leaving it floating. In this condition if a new cycle doesn't start within 30  $\mu$ s typ. from the previous one the PM6686 turns on the low-side MOSFET to discharge the output capacitor. The inductor current goes negative until the output reaches the voltage regulation voltage allowing a new cycle to begin. If the switching frequency is above 33 kHz the device works in SKIP mode.

This operation mode is useful to avoid audio noise but it lowers the efficiency at light loads if it is compared to the SKIP mode.

Figure 49. Inductor current and output voltage in NA SKIP mode



### 8.1.6 Gate drivers and logic supply

The integrated high-current drivers allow the use of different power MOSFET.

high-side driver is supplied with a bootstrap circuit with an integrated bootstrap diode. The BOOT and the PHASE pins work respectively as supply and return rails for the HS driver.

The PVCC pin is the input for the supply of the low-side driver and PGND is the pin used as return rail.

The PM6686 implements an anti-cross conduction protection which prevents high-side and low-side MOSFET from being on at the same time.

The power dissipation of each driver can be calculated as:

#### Equation 5

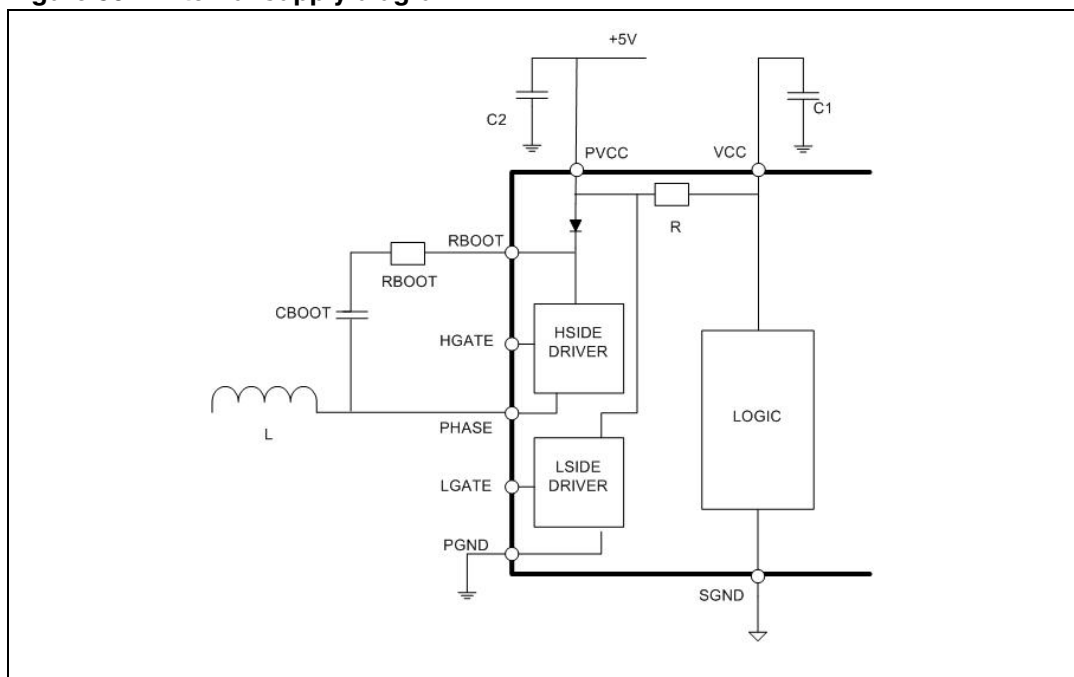
$$P_{DISS} = V_{PVCC} \cdot Q_G \cdot f_{sw}$$

Where  $V_{PVCC}$  is the voltage applied to PVCC pin (+5 V) and  $f_{sw}$  is the switching frequency.

The power dissipated by the drivers can be reduced lowering the sections switching frequencies and mounting MOSFET with smaller  $Q_G$ .

VCC pin is the input voltage rail to supply the internal logic circuit. This pin is connected internally with a resistor to PVCC. As usual analog supply should be divided by the power supply with a low pass filter to reduce the noise for the analog supply of the logic. Being the resistor integrated it is enough to put a decoupling capacitor near VCC pin to realize the filter with a components count reduction.

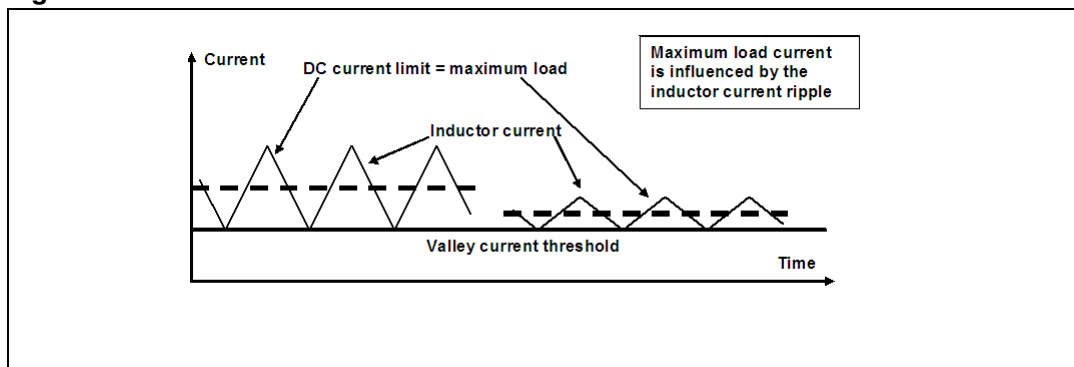
Figure 50. Internal supply diagram



### 8.1.7 Current sensing and current limit

The PM6686 implements a positive valley current limit to protect the application from an overcurrent fault. Each section has an independent current limit setting. A new switching cycle can't start until the inductor current is under the positive current limit threshold. Note that the peak current flowing in the inductor can reach a value greater than the current limit threshold by an amount equal to the inductor current ripple.

Figure 51. Current waveforms in current limit conditions



The inductor current is sensed during the off time  $T_{OFF}$  by measuring the voltage drop across the low-side MOSFET using the  $R_{DS(on)}$  as a lossless sensing element (PHASE to PGND voltage). The voltage drop is compared to the threshold set with ILIM pin. If ILIM is connected to a voltage higher than  $VCC-1V$  the limit is 100mV. A current of  $5\mu A$  is sourced from the pin ILIM; if a resistor is connected between ILIM and ground the current limit is given by the voltage at the ILIM pin. The device sets the PHASE voltage threshold at 1/10 of the ILIM voltage.

Figure 52. Current limit circuit block diagram

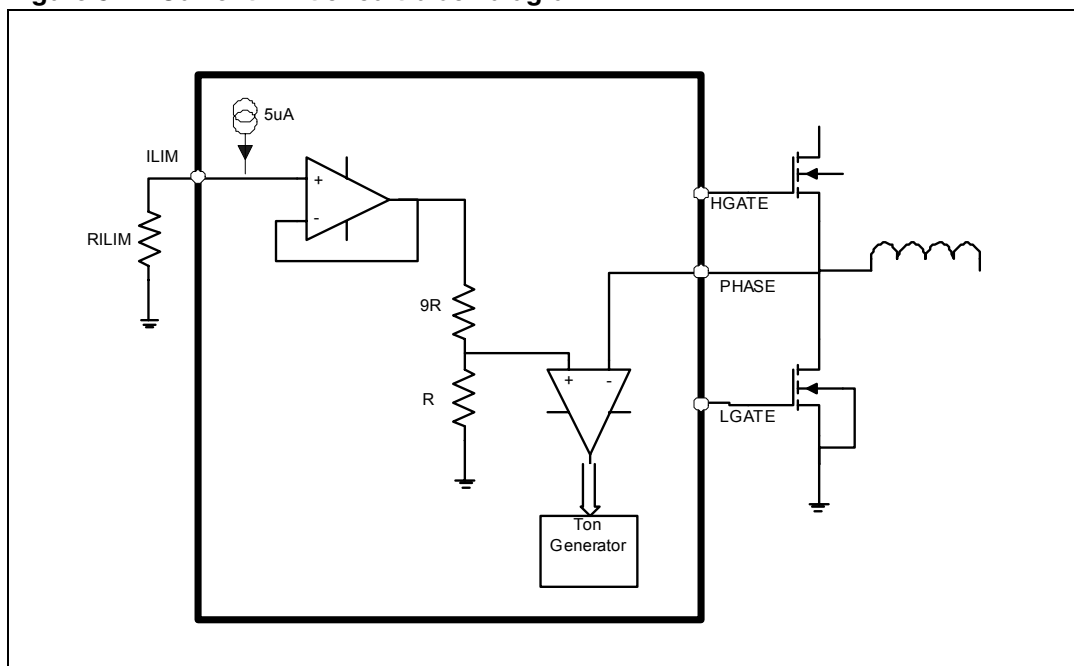


Table 10. Current limit configuration

Control pin	Control pin voltage	Threshold SET
ILIM1	$V_{ILIM} = V_{CC} - 1\text{ V}$	100 mV
ILIM2	$0.2\text{ V} = V_{ILIM} = 2\text{ V}$ $V_{ILIM} = 5\mu\text{A} * R_{ILIM}$	$V_{ILIM}/10$

A negative current control is also implemented: the low-side MOSFET is forced off when the current exceeds the negative limit. This function prevents the excessive negative inductor current during the PWM operating mode. The threshold is set approximately at the 120% of the positive current limit.

### 8.1.8 Soft-start and soft-end

The two sections have independent enable pins, EN1 and EN2. A not programmable soft-start procedure takes place when EN pin rises above 2.4 V typ.

To prevent high input inrush currents, the current limit is increased from 25% to 100% with steps of 25%.

The procedure is not programmable and ends typically in 2.8 ms. The overvoltage protection is always active while the undervoltage protection is enabled typically 20 ms after the beginning of the soft-start procedure.

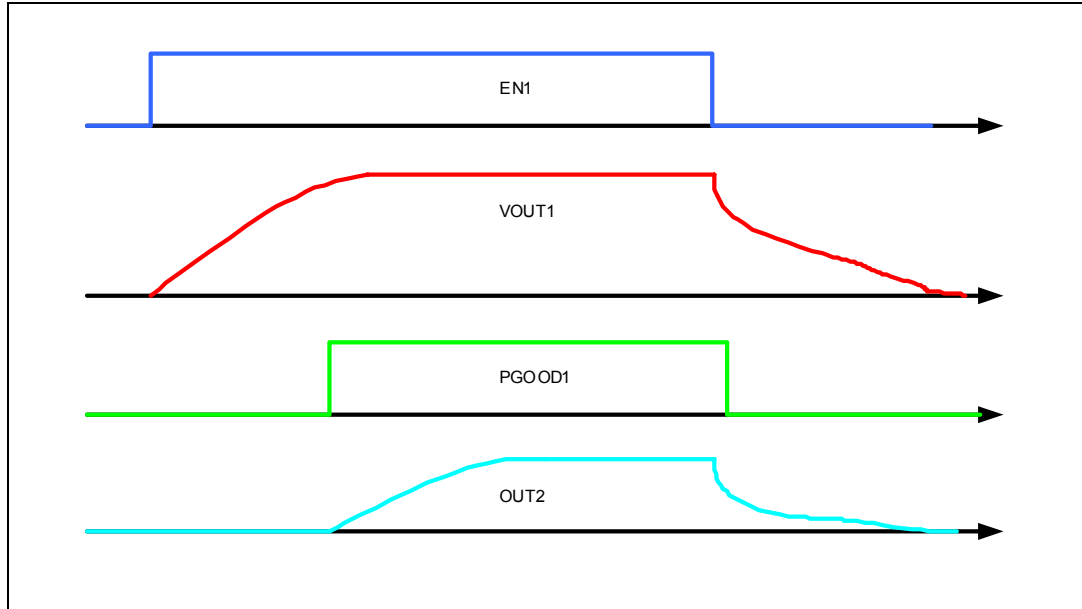
Driving one EN pin below 0.8 V makes the section perform a soft-end: gate driving signals are pulled low and the output is discharged through an internal MOSFET with  $R_{DS(on)}$  of 28 Ω typ.

A power up sequence for the switching sections can be selected connecting one EN pin to VREF2.



The section with the EN pin connected to VREF2 begins the soft-start only when the other section is in regulation (its PGOOD is high) and makes a soft-end suddenly when the other section is turned off.

**Figure 53. VOUT2 behavior if EN2 is connected to VREF2**



To protect the EN1, EN2, EN\_LDO and SKIP pin of the PM6686 an external divider or a series resistor is required, in order to prevent a large inrush current flowing into the device in case the voltage spike is exceeding the recommended operating conditions.

## 9 Monitoring and protections

The PM6686 controls its switching output to prevent any damage or uncontrolled working condition.

The device offers also PGOOD signals to monitor the state of each switching output voltage. PGOOD is an open drain output: it is pulled low if the output voltage is below the 90% or above the OVP threshold. of the nominal value.

### 9.1 Overvoltage protection

PM6686 provides a latched overvoltage protection (OVP). If the output voltage rises above the +111% typ. for section 1 and above the +116% typ. for the section 2, a latched OVP protection is activated. The controller tries to pull down the output voltage down to 0 V, working in PWM. The current is limited by the negative current limit. The low-side MOSFET is kept on when the output voltage is about 0 V. This management avoids high negative undervoltage of the output rail that may damage the load.

The protection is latched and this fault is cleared toggling cleared by toggling EN or by driving  $PVCC < 3.979V$  and then  $PVCC > 4.025V$  (PVCC Power On Reset).

### 9.2 Undervoltage protection

If during regulation the output voltage droops under the 70% of the nominal value, an undervoltage latched fault is detected. The controller performs a soft-end procedure (see “soft-start and soft-end” paragraph). The undervoltage fault is cleared by toggling EN or by driving  $PVCC < 3.979V$  and then  $PVCC > 4.025V$  (PVCC power on reset).

### 9.3 PVCC monitor

The device monitors the driver supply voltage at PVCC pin. The switching sections can start operating only if the voltage at PVCC pin is above 4,025 V typ. If PVCC falls below 3,979 V typ., both the switching sections are turned off until the PVCC voltage goes over 4,025 V typ.

**Table 11. Faults management summary**

Fault	Condition	Device reaction
Overvoltage section1	$V_{OUT} > +111\%$	Negative current limit protection activated. Low-side MOSFET is turned on when the output voltage is about 0 V. Latched fault, cleared by toggling EN or by driving $PVCC < 3.979V$ and then $PVCC > 4.025V$ (PVCC POR).
Overvoltage section 2	$V_{OUT} > +116\%$	Negative current limit protection activated. Low-side MOSFET is turned on when the output voltage is about 0 V. Latched fault, cleared by toggling EN or by driving $PVCC < 3.979V$ and then $PVCC > 4.025V$ (PVCC POR).
Undervoltage	$V_{OUT} < 70\%$	The controller performs a soft-end. Latched fault cleared by toggling EN or by driving $PVCC < 3.979V$ and then $PVCC > 4.025V$ (PVCC POR).
PVCC undervoltage	$PVCC < 3,979 V$	The controller turns off the switching sections. All faults of switching sections are cleared. Not latched fault

## 9.4 Linear regulator section

The PM6686 has an integrated linear regulator (LDO) that can provide an average of 100 mA typ. with a peak current of 270 mA typ. The LDO can be enabled using EN\_LDO pin. If VIN is applied the linear regulator is active even if PVCC is low.

The output voltage can be programmed by LDOREFIN pin. If LDOREFIN pin is tied to ground (GND) the LDO provides a +5 V output voltage. If it is connected to VREF3 pin the LDO regulates 3.3 V. If the voltage at the LDOREFIN pin is between 0.35 V and 2.25 V the LDO generates an output voltage equals to  $2 \times V_{LDOREFIN}$ .

**Table 12. LDO output voltage configuration**

LDOREFIN voltage	LDO voltage
GND	+5 V
VREF3	+3,3 V
$0,35 \text{ V} < V_{LDOREFIN} < 2,25 \text{ V}$	$2 \times V_{LDOREFIN}$

The controller provides a switchover function when LDOREFIN pin is connected to VCC or GND. If the voltage at LDO\_SW pin is high enough, the internal linear regulator is turned off and the LDO pin is connected with an internal MOSFET to the LDO\_SW pin. This feature decreases the power dissipation of the device.

When the switchover function is used the maximum current capability is 200 mA if LDO output is +5 V and 100 mA if the LDO output is +3.3 V.

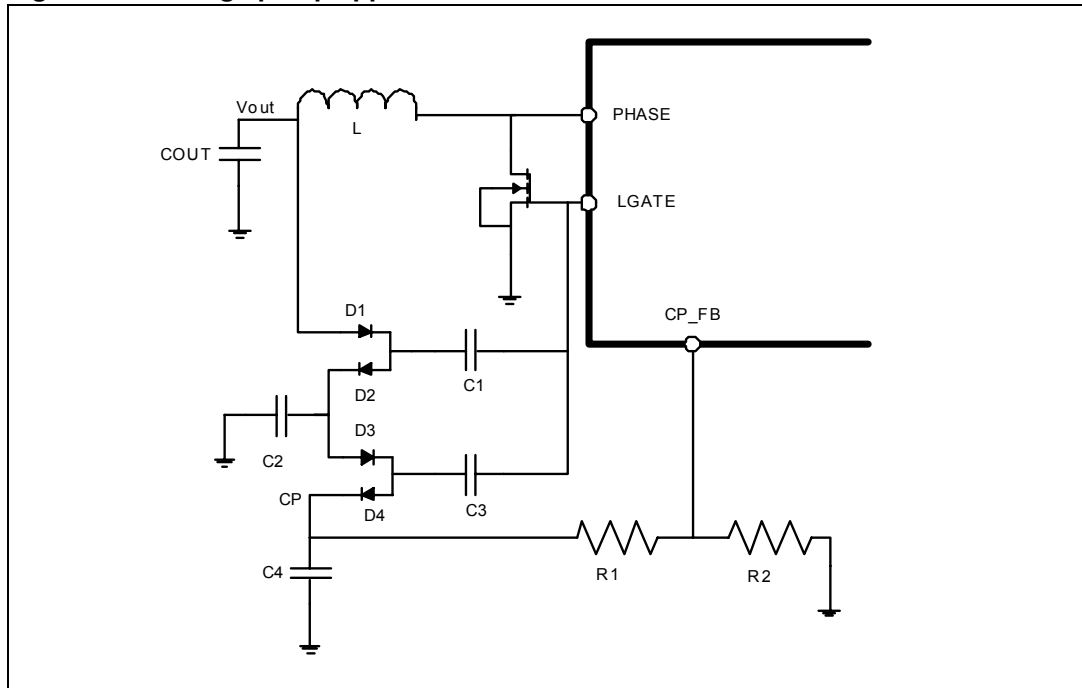
**Table 13. LDO switchover management**

$V_{LDOREFIN}$	$V_{BYPLDO\_SW}$	$V_{LDO}$	Internal LDO	Switchover resistance
< 0,35 V	> 4,75 V	+5 V	Disabled	0.81 $\Omega$
< 0,35 V	< 4,55 V	+5 V	Enabled	-
> 2.43 V	> 3.18 V	+3,3 V	Disabled	1.12 $\Omega$
> 2.43 V	< 3.05 V	+3,3 V	Enabled	-
$0,35 \text{ V} < V_{LDOREFIN} < 2,25 \text{ V}$		$2 \times V_{LDOREFIN}$	Enabled	-

## 9.5 Charge pump

The PM6686 can drive an external charge pump circuit whose typical application schematic is shown in the next figure.

**Figure 54. Charge pump application circuit**



The charge pump works in 4 phases:

1. LGATE is low. C1 is charged through the D1a diode at OUT1 voltage minus the diode drop.
2. LGATE is driven high and C1 transfers the charge to C2. C2 voltage is OUT1 voltage plus the LGATE voltage minus the voltage drops on D1 and D2.
3. LGATE is turned low and C2 shares its charge with C3 through D3.
4. LGATE becomes high and C3 can charge C4 through diode D4.

Every diode used to transfer charge introduces a voltage drop that decreases the charge pump output voltage.

Repeating this cycle several times makes the charge pump output voltage equals to:

### Equation 6

$$V_{CP} = V_{OUT1} + 2V_{LGATE1} - 4V_{DIODE}$$

Where  $V_{CP}$  is the charge pump output voltage,  $V_{OUT1}$  is the output voltage of the switching section 1,  $V_{LGATE1}$  is the low-side MOSFET gate driving voltage and  $V_{DIODE}$  is the forward voltage drop of the diodes used in the application.

CP\_FB pin must be connected to the output of the charge pump with a resistor divider; when CP\_FB pin droops below 2 V typ., OUT1 controller starts a NA SKIP cycle to boost the voltage of the charge pump.

The minimum voltage of the charge pump is:

**Equation 7**

$$V_{CP\_MIN} = V_{CP\_FB} \cdot \left( 1 + \frac{R_1}{R_2} \right)$$

Where  $V_{CP\_FB}$  is the minimum voltage of CP\_FB pin(2V typ.).

In case the charge pump feedback is not used, leave the CP\_FB pin floating or connect the pin to VCC.

## 9.6 Voltage references

The PM6686 provides two voltage references.

The device regulates a 3,3 V voltage reference (VREF3) with  $\pm 2\%$  accuracy over temperature. VREF3 can source up to 5 mA. VREF3 voltage is always available if  $V_{IN}$  is applied. The device allows the enabling of the outputs if VREF3 is above 2,8V typ. and turns off when VREF3 falls under 2,7 V typ.

VREF2 is a + 2 V reference with an accuracy of  $\pm 1\%$  over temperature. It can source up to 50  $\mu$ A typ. and sink up to 10  $\mu$ A. VREF2 is adopted as internal reference; this voltage can be used as voltage threshold to set configuration pins (e.g. TON, SKIP pins). VREF2 is enabled when one enable pin (EN1, EN2 or EN\_LDO) is pulled high.

## 9.7 General device fault management

### 9.7.1 Thermal protection

If the internal temperature of the device exceeds typically +150 °C, the controller shuts down immediately all the internal circuitry. Switching sections performs the soft-end management. Toggling EN, EN LDO or cycling VIN resets the latched fault.

## 10 Application information

### 10.1 External components selection

#### 10.1.1 Inductor

Once that switching frequency is defined, inductor selection depends on the desired inductor ripple current and load transient performance.

Low inductance means great ripple current and could generate great output noise. On the other hand, low inductor values involve fast load transient response.

A good compromise between the transient response time, the efficiency, the cost and the size is to choose the inductor value in order to maintain the inductor ripple current  $\Delta I_L$  between 20% and 50% of the maximum output current  $I_{LOAD}(\max)$ . The maximum  $\Delta I_L$  occurs at the maximum input voltage. With these considerations, the inductor value can be calculated with the following relationship:

##### Equation 8

$$L = \frac{V_{IN} - V_{OUT}}{f_{sw} \times \Delta I_L} \times \frac{V_{OUT}}{V_{IN}}$$

Where  $f_{sw}$  is the switching frequency,  $V_{IN}$  is the input voltage,  $V_{OUT}$  is the output voltage and  $\Delta I_L$  is the selected inductor ripple current.

In order to prevent overtemperature working conditions, inductor must be able to provide an RMS current greater than the maximum RMS inductor current  $I_{LRMS}$ :

##### Equation 9

$$I_{LRMS} = \sqrt{(I_{LOAD}(\max))^2 + \frac{(\Delta I_L(\max))^2}{12}}$$

Where  $\Delta I_L(\max)$  is the maximum ripple current:

##### Equation 10

$$\Delta I_L(\max) = \frac{V_{INmax} - V_{OUT}}{f_{sw} \times L} \times \frac{V_{OUT}}{V_{INmax}}$$

If hard saturation inductors are used, the inductor saturation current should be much greater than the maximum inductor peak current  $I_{peak}$ :

##### Equation 11

$$I_{peak} = I_{LOAD}(\max) + \frac{\Delta I_L(\max)}{2}$$

Using soft-saturation inductors it's possible to choose inductors with saturation current limit nearly to  $I_{peak}$ .

Below there is a list of some inductor manufacturers.

**Table 14. Inductor manufacturer**

Manufacturer	Series	Inductor value ( $\mu\text{H}$ )	RMS current (A)	Saturation current (A)
COILCRAFT	MSS-1048	3,3	7,22	7,6
COILCRAFT	MSS-1260	3,3	9,7	7
COILCRAFT	MLC-1550	2,5	16,5	11,4

### 10.1.2 Input capacitor

In a buck topology converter the current that flows into the input capacitor is a pulsed current with zero average value. The input RMS current of the two switching sections can be roughly estimated as follows:

**Equation 12**

$$I_{\text{CinRMS}} = \sqrt{D_1 \times I_1^2 \times (1 - D_1) + D_2 \times I_2^2 \times (1 - D_2)}$$

Where  $D_1$ ,  $D_2$  are the duty cycles and  $I_1$ ,  $I_2$  are the maximum load currents of the two sections.

Input capacitor should be chosen with an RMS rated current higher than the maximum RMS current given by both sections.

Tantalum capacitors are good in term of low ESR and small size, but they occasionally can burn out if subjected to very high current during the charge. Ceramic capacitors have usually a higher RMS current rating with smaller size and they remain the best choice.

Below there is a list of some ceramic capacitor manufacturers.

**Table 15. Input capacitor manufacturer**

Manufacturer	Series	Capacitor value ( $\mu\text{F}$ )	Rated voltage (V)
TAYIO YUDEN	UMK325BJ106 KM-T	10	50
TAYIO YUDEN	GMK325BJ106MN	10	35

### 10.1.3 Output capacitor

The selection of the output capacitor is based on the ESR value and on the voltage rating rather than on the capacitor value  $C_{\text{out}}$ .

The output capacitor has to satisfy the output voltage ripple requirements. Lower inductor value can reduce the size of the choke but increases the inductor current ripple  $\Delta I_L$ .

Since the voltage ripple  $V_{\text{RIPPLEout}}$  is given by:

**Equation 13**

$$V_{\text{RIPPLEout}} = R_{\text{out}} \times \Delta I_L$$

A low ESR capacitor is required to reduce the output voltage ripple. Switching sections can work correctly even with 15mV output ripple.

Finally the output capacitor choice deeply impacts on the load transient response. Below there is a list of some capacitor manufacturers.

Output capacitor manufacturer

**Table 16. Input capacitor manufacturer**

Manufacturer	Series	Capacitor value (µF)	Rated voltage (V)	ESR max (mΩ)
SANYO	POSCAP TPB	150 to 330	2.5 to 6.3	35 to 65
SANYO	POSCAP TPF	150 to 470	2.5 to 6.3	7 to 15

### 10.1.4 MOSFET

Logic-level MOSFETs are recommended, since low-side and high-side gate drivers are powered by PVCC. Their breakdown voltage (VBRDSS) must be higher than the maximum input voltage.

In notebook applications, power management efficiency is a high level requirement. The power dissipation on the power switches becomes an important factor in switching selections. Losses of high-side and low-side MOSFETs depend on their working conditions.

The power dissipation of the high-side MOSFET is given by:

**Equation 14**

$$P_{DHighSide} = P_{conduction} + P_{switching}$$

Maximum conduction losses are approximately:

**Equation 15**

$$P_{conduction} = R_{DS(on)} \times \frac{V_{OUT}}{V_{INmin}} \times I_{LOAD(max)}^2$$

Where  $R_{DS(on)}$  is the drain-source on resistance of the high-side MOSFET.

Switching losses are approximately:

**Equation 16**

$$P_{switching} = \frac{V_{IN} \times (I_{LOAD(max)} - \frac{\Delta I_L}{2}) \times t_{on} \times f_{sw}}{2} + \frac{V_{IN} \times (I_{LOAD(max)} + \frac{\Delta I_L}{2}) \times t_{off} \times f_{sw}}{2}$$

Where  $t_{on}$  and  $t_{off}$  are the switching times of the turn on and turn off phases of the MOSFETs.

As general rule, high-side MOSFETs with low gate charge are recommended, in order to minimize driver losses.

Below there is a list of possible choices for the high-side MOSFETs.



**Table 17. High-side MOSFET manufacturer**

Manufacturer	Type	Gate charge (nC)	R <sub>DS(on)</sub> (mΩ)	Rated reverse voltage (V)
ST	STS12NH3LL	10	8	30
ST	STS17NH3LL	18	4	30

The power dissipation of the low-side MOSFET is given by:

**Equation 17**

$$P_{D\text{LowSide}} = P_{\text{conduction}}$$

Maximum conduction losses occur at the maximum input voltage:

**Equation 18**

$$P_{\text{conduction}} = R_{DS(on)} \times \left(1 - \frac{V_{OUT}}{V_{INmax}}\right) \times I_{LOAD(max)}^2$$

Choose a synchronous rectifier with low R<sub>DS(on)</sub>. When high-side MOSFET turns on, the fast variation of the phase node voltage can bring up even the low-side gate through its gate-drain capacitance CRSS, causing cross-conduction problems. Choose a low-side MOSFETs that minimizes the ratio CRSS/CGS (CGS = CISS - CRSS).

Below there is a list of some possible low-side MOSFETs.

**Table 18. Low-side MOSFET manufacturer**

Manufacturer	Type	R <sub>DS(on)</sub> (mΩ)	$\frac{C_{RSS}}{C_{GS}}$	Rated reverse voltage (V)
ST	STS17NF3LL	5.5	0.047	30
ST	STS25NH3LL	3.5	0.011	30

Dual N-channel MOSFETs can be used in applications with a maximum output current of about 3 A. Below there is a list of some MOSFETs manufacturers.

**Table 19. Dual MOSFET manufacturer**

Manufacturer	Type	R <sub>DS(on)</sub> (mΩ)	Gate charge (nC)	Rated reverse voltage (V)
ST	STS8DNH3LL	25	10	30
ST	STS4DNF60L	65	32	60

## 11 Diode selection

### 11.1 Freewheeling diode

A rectifier across the low-side MOSFET is recommended. The rectifier works as a voltage clamp across the synchronous rectifier and reduces the negative inductor swing during the dead time between turning the high-side MOSFET off and the synchronous rectifier on. It can increase the efficiency of the switching section, since it reduces the low-side switch losses. A Schottky diode is suitable for its low forward voltage drop (0.3 V). The diode reverse voltage must be greater than the maximum input voltage. A minimum recovery reverse charge is preferable. Below there is a list of some Schottky diode manufacturers.

**Table 20. Schottky diode manufacturer**

Manufacturer	Series	Forward voltage (V)	Rated reverse voltage (V)	Reverse current ( $\mu\text{A}$ )
ST	STPS1L30M	0.34	30	0.00039
ST	STPS1L20M	0.37	20	0.000075

### 11.2 Charge pump diode

The charge pump capacitors are fed by the current supplied by LGATE1 (output of the low-side driver for the section 1). Dual in package diodes, in series configuration, could be used to reduce the area occupation.

**Table 21. Schottky diode manufacturer**

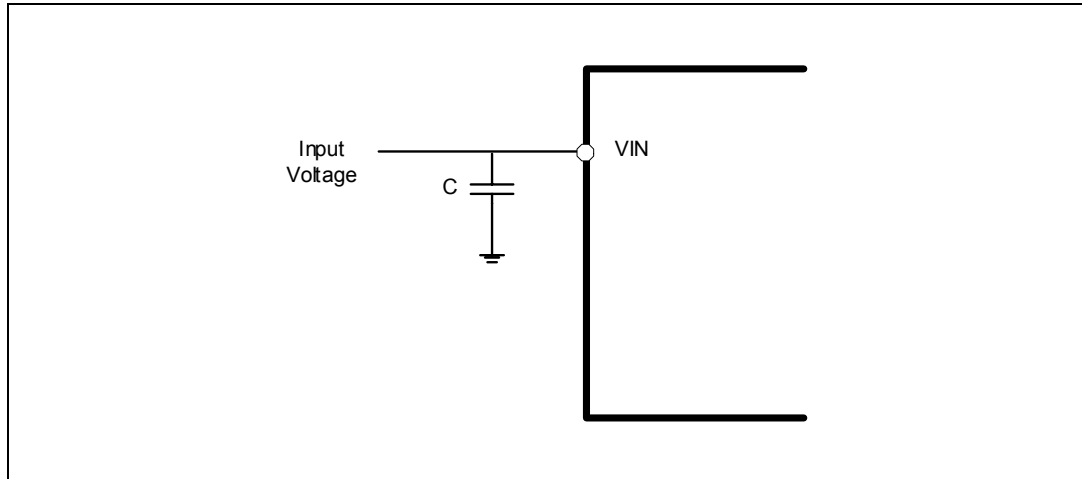
Manufacturer	Series	Forward voltage (V)	Rated reverse voltage (V)	Max forward current (A)
ST	BAT54S	0.24	40	0.3
ST	BAR43A	0.35	30	0.1
ST	BAS69-04	0.35	15	0.01

## 11.3 Other important components

### 11.3.1 VIN filter

A VIN pin low pass filter is suggested to reduce switching noise. The low pass filter is shown in the next figure:

**Figure 55. VIN pin filter**



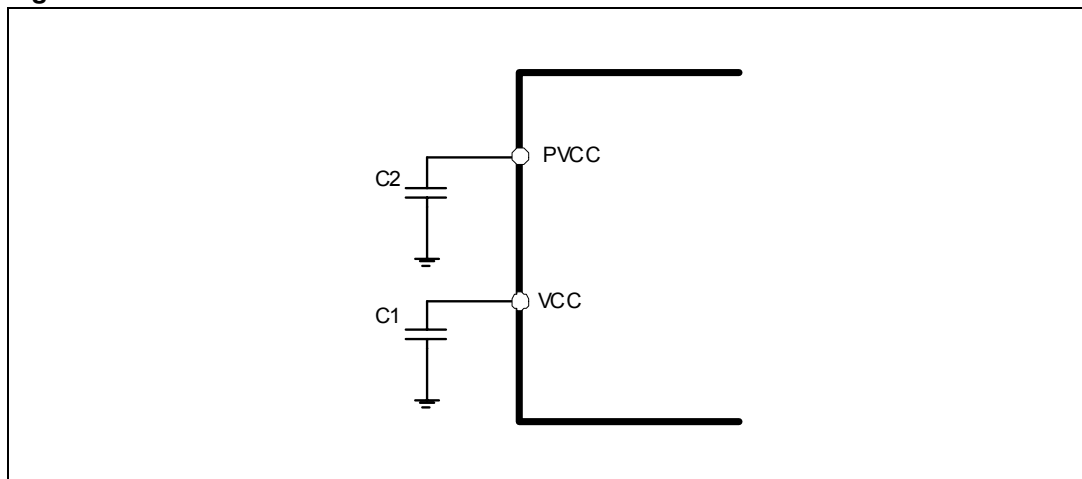
Typical component value is:  $C = 1 \mu\text{F}$ .

### 11.3.2 PVCC and VCC

PVCC and VCC are connected with an internal resistor (about  $10 \Omega$ ); this allows reducing the external components. Connect the +5 V supply rail only to PVCC.

Use a bypass capacitor on PVCC pin. A VCC low pass filter helps to reject switching commutations noise, this filter can be implemented simply adding a bypass capacitor on VCC pin.

**Figure 56. VCC and PVCC filters**



Typical components values are:  $C1 = 1 \mu\text{F}$  and  $C2 = 1 \mu\text{F}$ .

### 11.3.3 VREF2 and VREF3 capacitors

A 10 nF to 100 nF ceramic capacitor on VREF2 pin must be added to ensure noise rejection. If VREF3 voltage is not used the pin can be left floating, otherwise a 10 nF to 100 nF bypass ceramic capacitor should be mounted.

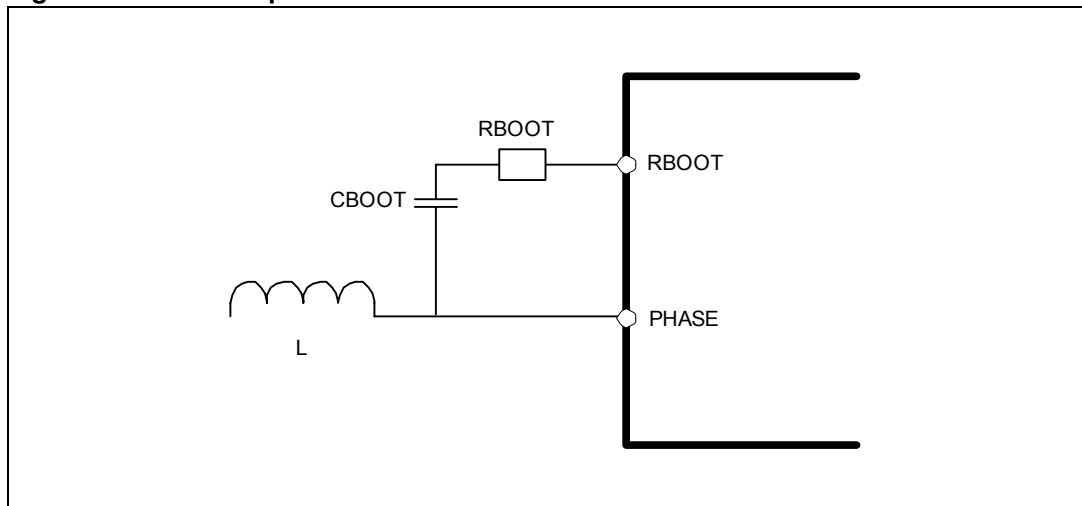
### 11.3.4 LDO output capacitors

Bypass the output of the linear regulator with 4,7  $\mu\text{F}$  ceramic capacitor closer to the LDO pin. In most applicative conditions the ceramic output capacitor can be enough to ensure stability.

### 11.3.5 Bootstrap circuit

The external bootstrap circuit is represented in the next figure:

**Figure 57. Bootstrap circuit**



The bootstrap circuit capacitor value  $C_{BOOT}$  must provide the total gate charge to the high-side MOSFET during turn on phase. A typical value is 100 nF.

A resistor  $R_{BOOT}$  on the BOOT pin could be added in order to reduce noise when the phase node rises up, working like a gate resistor for the turn on phase of the high-side MOSFET. A typical value is  $R_{BOOT} = 1 \Omega$ .

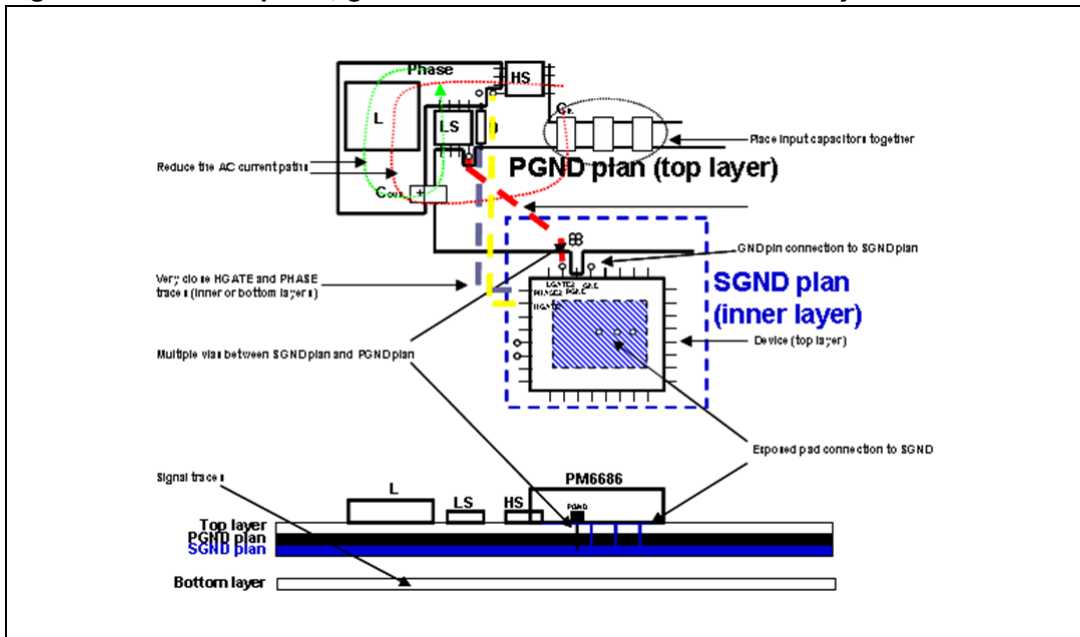
## 12 PCB design guidelines

The layout is very important in terms of efficiency, stability and noise of the system. It is possible to refer to the PM6686 demonstration board for a complete layout example.

For good PC board layout follows these guidelines:

- Place on the top side all the power components (inductors, input and output capacitors, MOSFETs and diodes). Refer them to a power ground plan, PGND. If possible, reserve a layer to PGND plan. The PGND plan is the same for both the switching sections.
- AC current paths layout is very critical (see [Figure 58](#)). The first priority is to minimize their length. Trace the LS MOSFET connection to PGND plan as short as possible. Place the synchronous diode D near the LS MOSFET. Connect the LS MOSFET drain to the switching node with a short trace.
- Place input capacitors near HS MOSFET drain. It is recommended to use the same input voltage plan for both the switching sections, in order to put together all input capacitors.
- Place all the sensitive analog signals (feedbacks, voltage references, current sense paths) on the bottom side of the board or in an inner layer. Isolate them from the power top side with a signal ground layer, SGND. Connect the SGND and PGND plans only in one point (a multiple vias connection is preferable to a  $0\ \Omega$  resistor connection) near the PGND device pin. Place the device on the top or on the bottom size and connect the exposed pad and the SGND pins to the SGND plan (see [Figure 58](#)).
- As general rule, make the high-side and low-side drivers traces wide and short.
- The high-side driver is powered by the bootstrap circuit. It's very important to place capacitor CBOOT as near as possible to the BOOT pin (for example on the layer opposite to the device). Route HGATE and PHASE traces as near as possible in order to minimize the area between them.
- The low-side gate driver is powered by PVCC pin. Placing PGND and LGATE pins near the low-side MOSFETs reduces the length of the traces and the crosstalk noise between the two sections.
- The linear regulator outputs are referred to SGND as long as the reference voltages VREF2 and VREF3. Place their output filtering capacitors as near as possible to the device.
- Place input filtering capacitors near PVCC, VCC and VIN pins.

Figure 58. Current paths, ground connection and driver traces layout



## 13 Package mechanical data

In order to meet environmental requirements, ST offers these devices in different grades of ECOPACK<sup>®</sup> packages, depending on their level of environmental compliance. ECOPACK<sup>®</sup> specifications, grade definitions and product status are available at: [www.st.com](http://www.st.com). ECOPACK is an ST trademark.

**Table 22. VFQFPN 5x5x1.0 mm 32 L pitch 0.50 mechanical data**

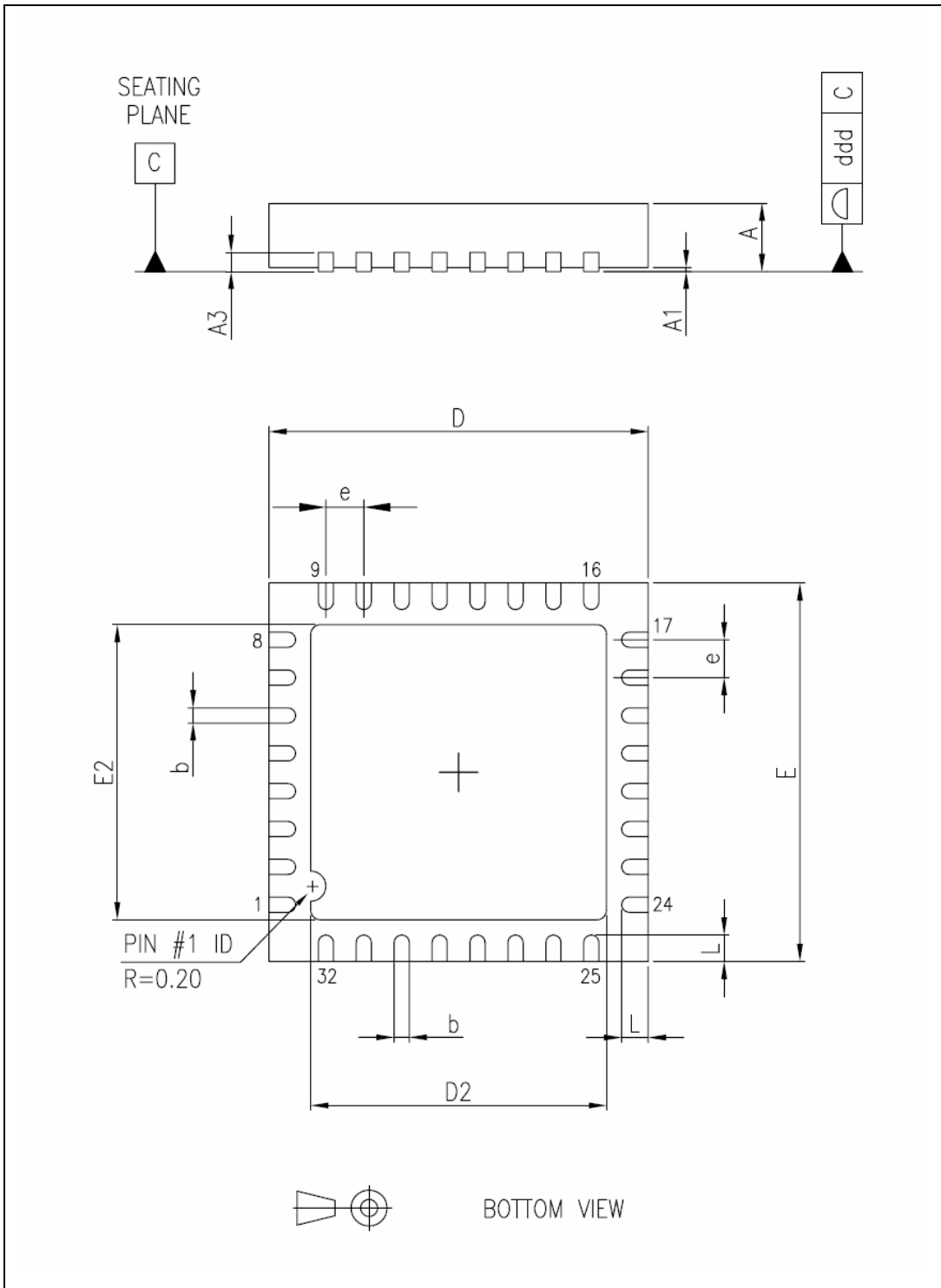
Dim.	Databook (mm)		
	Min	Typ	Max
A	0.8	0.9	1
A1	0	0.02	0.05
A3		0.2	
b	0.18	0.25	0.3
D	4.85	5	5.15
D2	See exposed pad variations <sup>(2)</sup>		
E	4.85	5	5.15
E2	See exposed pad variations <sup>(2)</sup>		
e		0.5	
L	0.3	0.4	0.5
ddd			0.05

**Table 23. Exposed pad variations**

D2			E2		
Min	Typ	Max	Min	Typ	Max
2.90	3.10	3.20	2.90	3.10	3.20

1. VFQFPN stands for thermally enhanced very thin fine pitch quad flat package no lead. Very thin: A = 1.00 mm max.
2. Dimensions D2 and E2 are not in accordance with JEDEC.

Figure 59. Package dimensions





## 14 Revision history

**Table 24. Document revision history**

Date	Revision	Changes
09-Jan-2009	1	Initial release
26-Feb-2009	2	Updated input voltage range in coverpage
07-May-2009	3	Updated pin 29 description in <a href="#">Table 2 on page 7</a>
23-Jul-2009	4	Updated <a href="#">Table 3 on page 10</a> , <a href="#">Section 8.1.8 on page 32</a> , <a href="#">Section 9.1 on page 34</a> , <a href="#">Section 9.2 on page 34</a> and <a href="#">Table 11 on page 34</a>

**Please Read Carefully:**

Information in this document is provided solely in connection with ST products. STMicroelectronics NV and its subsidiaries ("ST") reserve the right to make changes, corrections, modifications or improvements, to this document, and the products and services described herein at any time, without notice.

All ST products are sold pursuant to ST's terms and conditions of sale.

Purchasers are solely responsible for the choice, selection and use of the ST products and services described herein, and ST assumes no liability whatsoever relating to the choice, selection or use of the ST products and services described herein.

No license, express or implied, by estoppel or otherwise, to any intellectual property rights is granted under this document. If any part of this document refers to any third party products or services it shall not be deemed a license grant by ST for the use of such third party products or services, or any intellectual property contained therein or considered as a warranty covering the use in any manner whatsoever of such third party products or services or any intellectual property contained therein.

**UNLESS OTHERWISE SET FORTH IN ST'S TERMS AND CONDITIONS OF SALE ST DISCLAIMS ANY EXPRESS OR IMPLIED WARRANTY WITH RESPECT TO THE USE AND/OR SALE OF ST PRODUCTS INCLUDING WITHOUT LIMITATION IMPLIED WARRANTIES OF MERCHANTABILITY, FITNESS FOR A PARTICULAR PURPOSE (AND THEIR EQUIVALENTS UNDER THE LAWS OF ANY JURISDICTION), OR INFRINGEMENT OF ANY PATENT, COPYRIGHT OR OTHER INTELLECTUAL PROPERTY RIGHT.**

**UNLESS EXPRESSLY APPROVED IN WRITING BY AN AUTHORIZED ST REPRESENTATIVE, ST PRODUCTS ARE NOT RECOMMENDED, AUTHORIZED OR WARRANTED FOR USE IN MILITARY, AIR CRAFT, SPACE, LIFE SAVING, OR LIFE SUSTAINING APPLICATIONS, NOR IN PRODUCTS OR SYSTEMS WHERE FAILURE OR MALFUNCTION MAY RESULT IN PERSONAL INJURY, DEATH, OR SEVERE PROPERTY OR ENVIRONMENTAL DAMAGE. ST PRODUCTS WHICH ARE NOT SPECIFIED AS "AUTOMOTIVE GRADE" MAY ONLY BE USED IN AUTOMOTIVE APPLICATIONS AT USER'S OWN RISK.**

Resale of ST products with provisions different from the statements and/or technical features set forth in this document shall immediately void any warranty granted by ST for the ST product or service described herein and shall not create or extend in any manner whatsoever, any liability of ST.

ST and the ST logo are trademarks or registered trademarks of ST in various countries.

Information in this document supersedes and replaces all information previously supplied.

The ST logo is a registered trademark of STMicroelectronics. All other names are the property of their respective owners.

© 2009 STMicroelectronics - All rights reserved

STMicroelectronics group of companies

Australia - Belgium - Brazil - Canada - China - Czech Republic - Finland - France - Germany - Hong Kong - India - Israel - Italy - Japan - Malaysia - Malta - Morocco - Philippines - Singapore - Spain - Sweden - Switzerland - United Kingdom - United States of America

[www.st.com](http://www.st.com)