

Reference Design Note

MagI³C Power Modules DNS005 MagI³C Multi Color LED Driver



1. Introduction

The MagI³C Multi Color 4 channel LED driver reference design demonstrates how four MagI³C LED Step Down High Current Modules (172946001) can be used to control the intensity and color of 4 individual LED strings.

The controlling can be done via hardware or software. An App for IOS was developed to control the reference design using Bluetooth. A user panel (1780051) was designed to adjust the intensity of each channel. The board can be used for horticulture, mixing of different white color temperatures, mixing of RGBW LED combinations (Red, Green, Blue, White) or just to change the intensity of one type of LED.

This board has a size of 115x115mm and four layers of copper for heat dissipation. The board includes an EMI filter in order to comply with the limits of the EN55015 conducted lighting norm and the CISPR32 norm for radiated EMI (tested with 1m output cable length) even while dimming the LED strings.

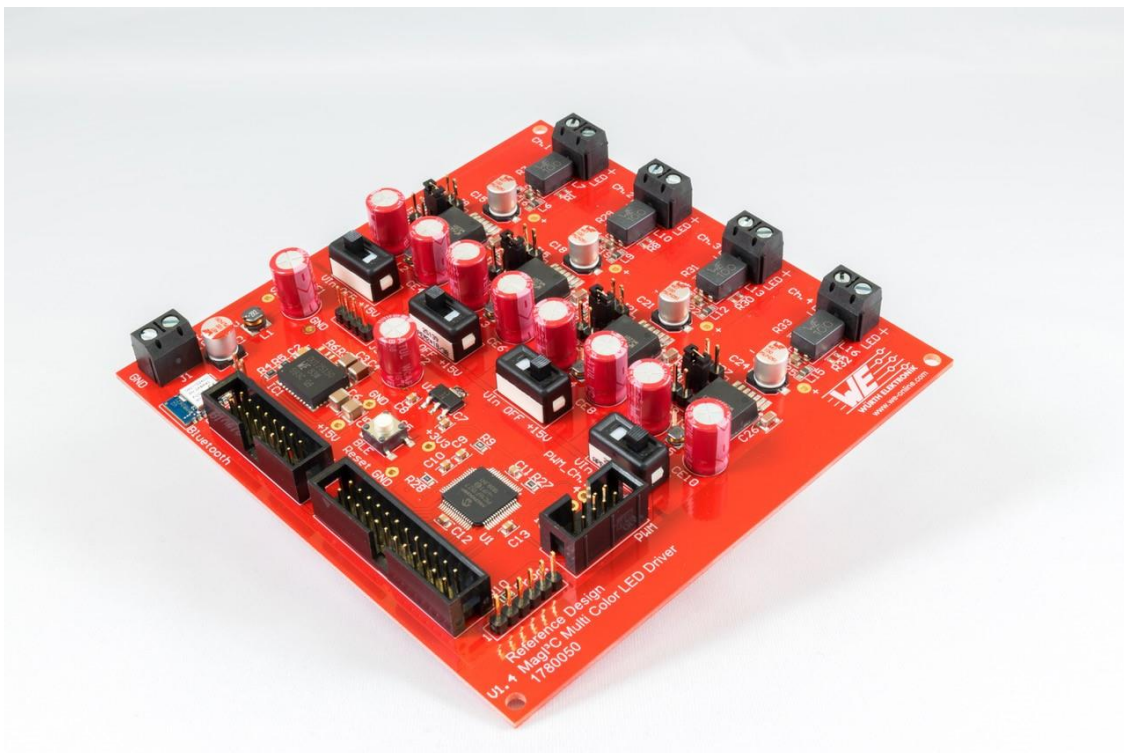

Figure 1. Multi Color Reference Design (Power Board)

Reference Design Note

Magl³C Power Modules DNS005 Magl³C Multi Color LED Driver



2. Specifications

Electrical Specifications

- Input Voltage Range: 18V – 48V
- Input Voltage Transients: Max. 50V
- Output Voltage Range: 0V – V_{IN}
- Output Current: 0mA – 450mA

Features

- 4 Channel LED Driver (can be extended by connecting daughter board)
- 1-26 LEDs with 1,8V each in series per channel (depending on LED forward voltage)
- Intensity of each channel can be adjusted individually (dimming 0-100%)
- Color mixing with four channels and RGBW LEDs
- Dimming by potentiometer, button or Bluetooth control (2608011024000)
- PWM dimming method - controlled by PIC16F1527 microcontroller
- Dimming profiles and colors can be stored
- LED Driver: Magl³C Power Module 172 946 001
- Conducted and radiated EMI compliant (EN55015)
- Good thermal behavior

3. Functional Description

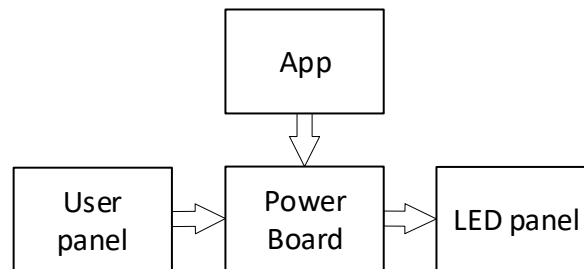

Figure 2: Block Diagram

The reference design consists of three parts: the power board, a control unit and the LED panel. The control unit can be an App for iOS from the App-Store named "WEilluminate" or the user panel 1780051. The user panel allows for manipulation of the PWM duty cycle using either the potentiometer or the digital buttons connected to the microcontroller. The power board 1780050 converts the signals from the controlling unit to a PWM signal, which controls four independent channels with an LED Step Down High Current Module (LDHM) on each channel. The four channels are built identically, each include an input and output filter to comply to the EMI norm.

Reference Design Note

MagI³C Power Modules DNS005 MagI³C Multi Color LED Driver

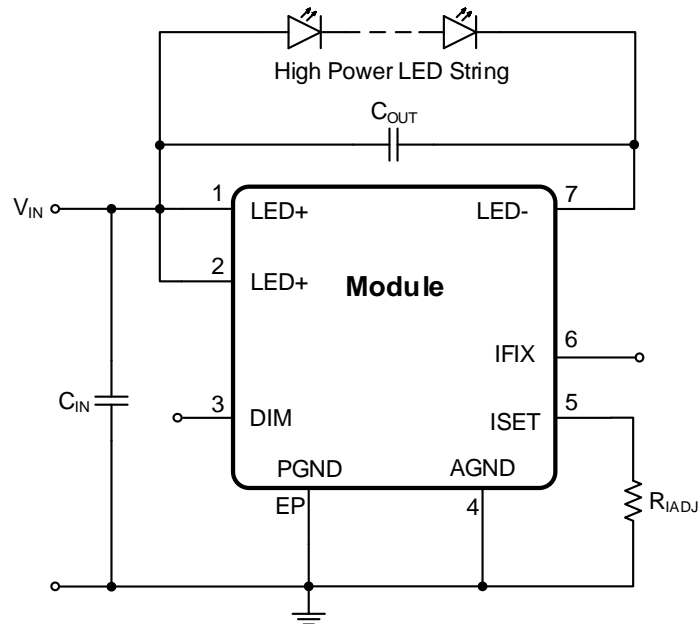

Figure 3: Typical LDHM Circuit Diagram

The LDHM (172946001) of the Würth Elektronik MagI³C Power Module Series is an LED driver based on a floating buck regulator (see Figure 4). The module is able to deliver both constant and pulsed currents. The TO263 package integrates the inductor, the free-wheeling diode and the regulator IC. It delivers an output current of up to 450mA at an output voltage from 4,5V to 60V. The output voltage is limited by the input voltage of the module as the input voltage must be equal to or greater than the desired output voltage for proper operation.

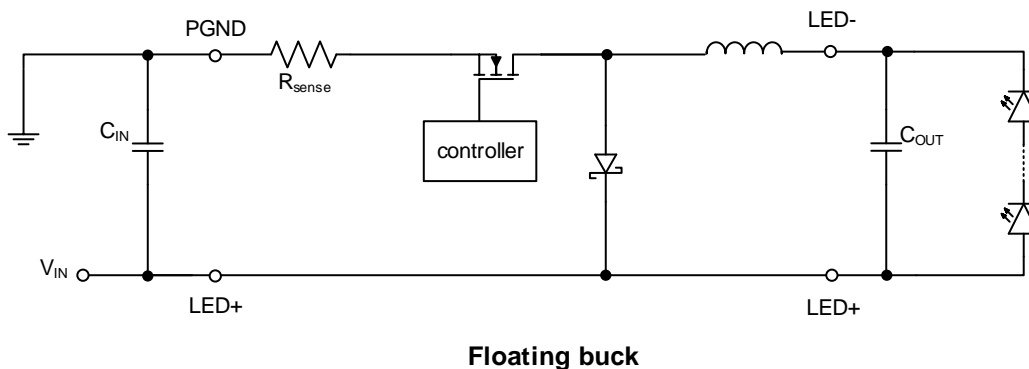

Figure 4: Floating Buck Topology

Reference Design Note

MagI³C Power Modules DNS005 MagI³C Multi Color LED Driver



3.1 Dimming with the LED Driver module

The LDHM (172946001) supports fast Pulse-Width Modulation (PWM) dimming of LEDs. An external microcontroller controls the dimming of the LED driver by supplying the PWM signal to the DIM pin of the LED driver. This signal activates and deactivates the MOSFET delivering power to the output of the LED driver. In addition, the dim-frequency depends on the contrast ratio (CR) of the PWM signal. The CR defines the maximum dim-steps.

The PWM dimming is based on the refresh rate of the human eye. Therefore the current through the LED is periodically interrupted with a frequency of 100 Hz to 1 kHz at the same amplitude. The longer the LED is interrupted, the less bright is the intensity of the LED for the human eye. Due to the limitations of the human eye, humans will not see the flickering if the dimming frequency is above 200 Hz. For camera applications, the frequency should be higher than 1 kHz to ensure the dimming frequency is unobservable.

The advantage of this dimming method is that there are rarely differences in brightness or in color. This is because the magnitude of the current through the LED is constant during the on time of the dimming cycle. Especially in the lower percentages of the dimming value, this advantage benefits most.

There are important design considerations which have been taken into account when using this reference design due to the use of PWM-controlled dimming. The frequency of the PWM signal can cause electromagnetic interference by resonating with other elements of the system and potentially result in the manifestation of piezoelectric effects in the MLCCs. Additionally, the PWM signal must have a controllable duty cycle to allow for manipulation of the dimming behavior.

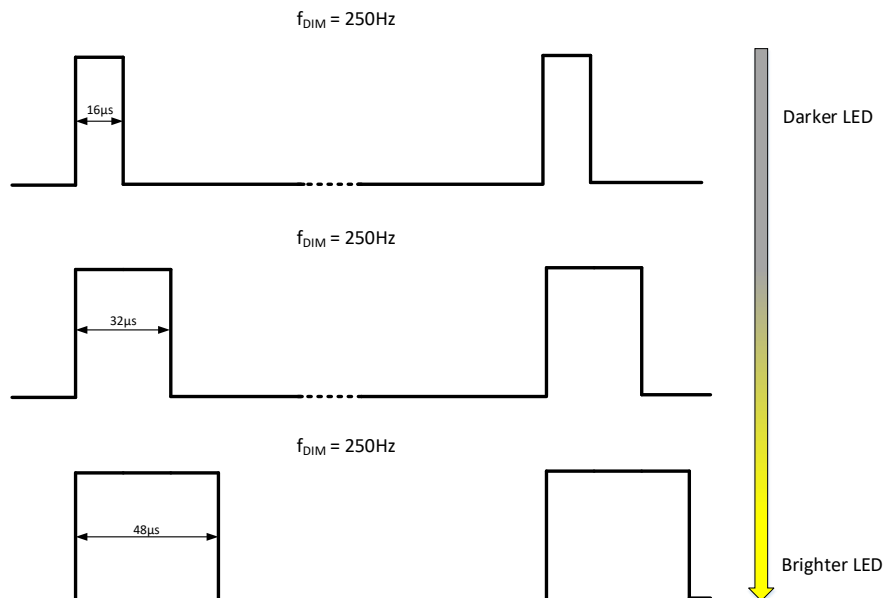

Figure 5: Dimming with the LDHM

Reference Design Note



MagI³C Power Modules DNS005 MagI³C Multi Color LED Driver

The 1780050 reference design uses a PWM frequency of 250 Hz which is generated by a PIC16F1527 microcontroller. The signal is directly connected from the microcontroller to the DIM pin of the LDHM. With an 8-bit contrast ratio, 255 different duty cycle steps are possible. With the 5k Ohm potentiometer on the user panel and the reference voltage of 3,3V you can use an analog signal with an analog-digital converter to change the duty cycle from 0 to 100%. Otherwise, you can also use the buttons to increase or decrease the duty cycle of the PWM signal. The duty cycle can be adjusted one time every 10ms.

3.2 Concept description

The input voltage of the board is limited to 48V due to the fact that the most common supply voltages are 24V and 48V. Since the total forward voltage of all LEDs per string limits the amount of LEDs, the input voltage needed to be as high as possible. Jumpers can set the maximum output current to 300mA, 350mA or 450mA at 100% duty cycle.

The Bluetooth Smart 4.2 Modul BLE T&R (2608011024000) of Würth Elektronik needs an input voltage of 3,3V. Therefore, the microcontroller is also chosen with the same input voltage. The LED driver has specific requirements when operating at high input voltages so an alternative supply is implemented using the BQFN-41 module (171021501) to provide a 15V input from the 48V supply line. This is particularly useful when less than six LEDs are connected to the output of the design. This 15V output is stepped down to 3,3V by an LDO. Because the current of the microcontroller and of the Bluetooth module is only about 25mA, the power losses are negligible.

In addition, the selection criteria for the microcontroller were a minimum of four hardware PWM-outputs, five A/D-converter inputs, enough GPIOs to realize all the intended features and a UART-interface for Bluetooth communication. Therefore, the PIC16F1527 from Microchip was chosen.

The four LED drivers are designed in accordance to the 172946001 evaluation board and data sheet. All channels are built exactly the same way and the supply voltage can be selected between the input voltage and 15 V with a switch. The board is split into three different parts. The first part is the supply section where the different input voltages are generated. In the control part, the microcontroller programmed in C with the software MPLAB X IDE controls the color and intensity mixing based on the different duty cycles of the four PWM signals. The third and main part is the power section with the four LED drivers. The control units are provided on an external user panel board for ease of use. This panel can be connected by ribbon cable and is an alternative to using the control app.

Reference Design Note

MagI³C Power Modules

DNS005 MagI³C Multi Color LED Driver

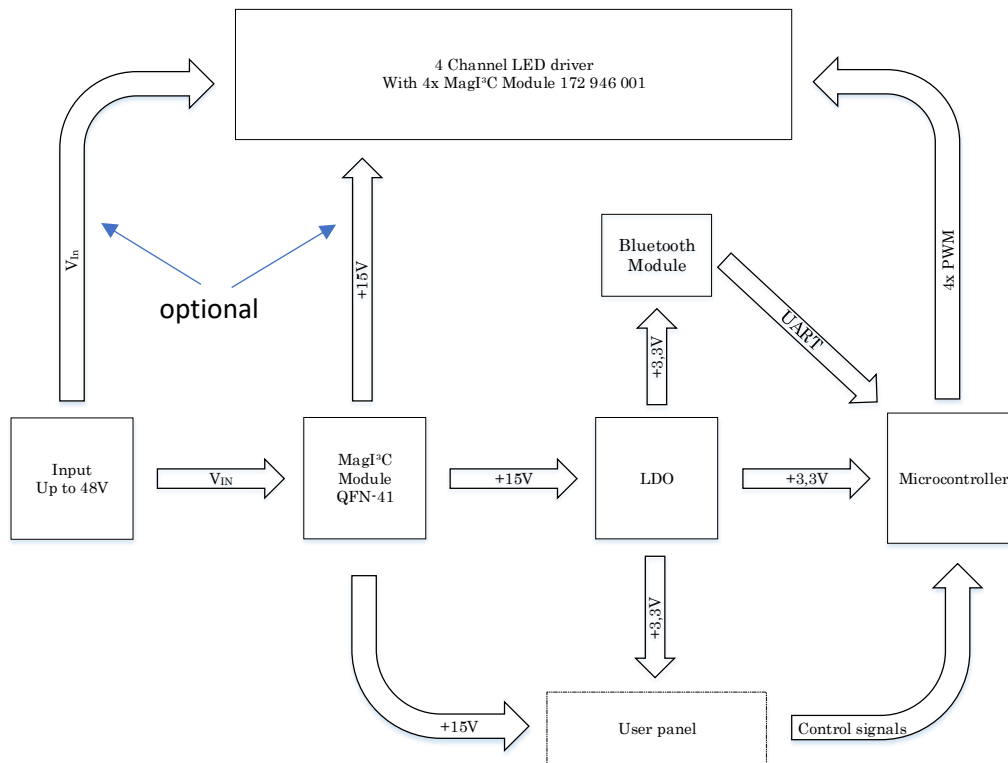

Figure 6: Multi Color Reference Design Power distribution concept and functional diagram

The input voltage is connected to the input pins of the four MagI³C LED drivers (172 946 001) and to the MagI³C QFN-41 Module. The QFN-41 (171021601) converts the input voltage to a fixed voltage of 15V. The input voltage can be changed from V_{in} to 15V by using the onboard switch. The LDO generates 3,3V and supplies the Bluetooth Module (2608011024000), the control units of the user panel and the PIC16F1527 microcontroller. The microcontroller can receive commands from the user panel as control signals or from the Bluetooth app via UART which it uses to determine the behavior of the four unique 250Hz PWM signals sent to each LED driver.

Reference Design Note

MagI³C Power Modules DNS005 MagI³C Multi Color LED Driver



4. Description

4.1 Complete system: Power Board, User Panel and LED Panel

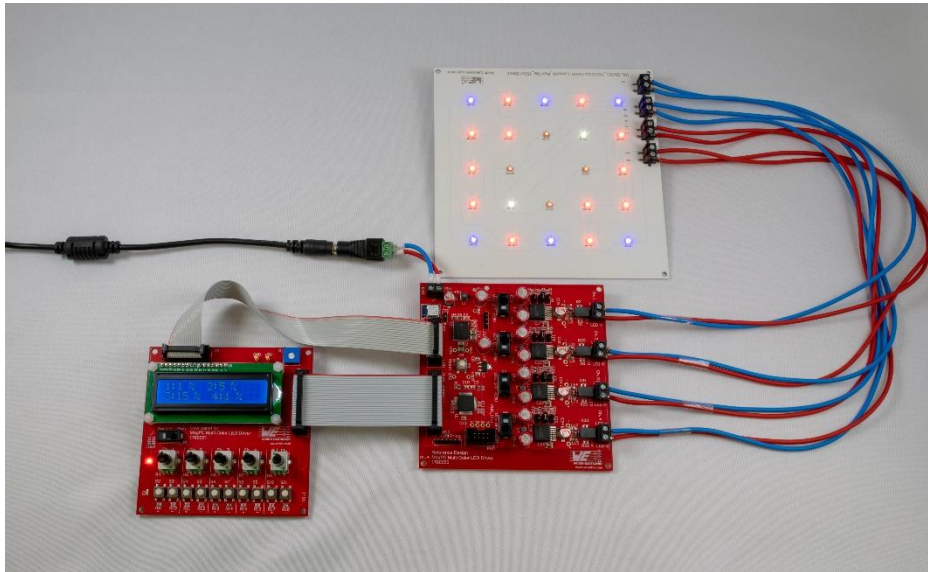
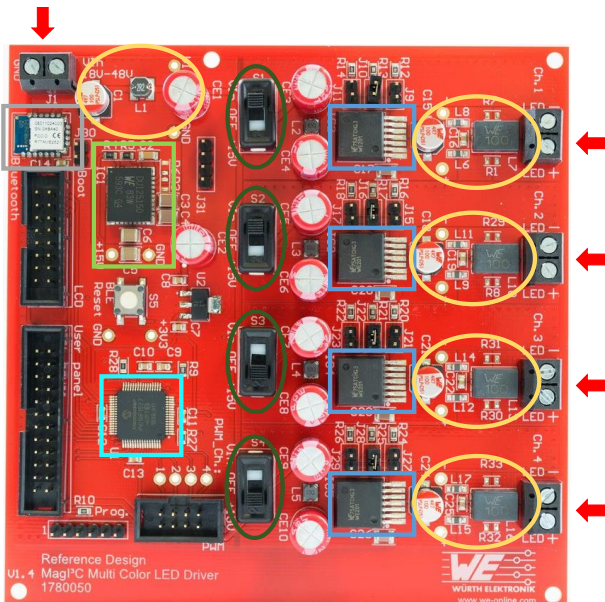

Figure 7: Complete System

4.2 Power Board



- 18-48V_{in} ; 1,8-V_{in} V_{out} ; up to 450mA
- LDHM LED Step Down High Current Module 172946001
- VDRM Variable Step Down Regulator Module QFN-41 171021501
- PIC16F1527 Microcontroller
- Bluetooth 4.2 Smart Module (260811024000)
- Switch between V_{in}, Off and +15V
- Input and Output Filter
- Robust screw terminal for V_{in} and V_{out}

Figure 8: Power Board

The jumpers next to the LED drivers change the maximum output current for each channel. Jumper J9, J15, J20 and J27 will set the current to 300mA. With J10, J16, J21 and J28 the current is limited to 350mA. The maximum output current of 450mA is set with the jumpers J11, J17, J22 and J29. Please note that you should only set one jumper per channel,

Reference Design Note



Mag³C Power Modules DNS005 Mag³C Multi Color LED Driver

otherwise the output current will be different than the values indicated in this document. The connector “PWM” can be used to connect a second power board, where only the LED driver power section and filters are mounted (no control units). All voltages and signals are delivered by the connector (four PWM signals, V_{in} , +15V, +3,3V and GND).

4.3 User Panel

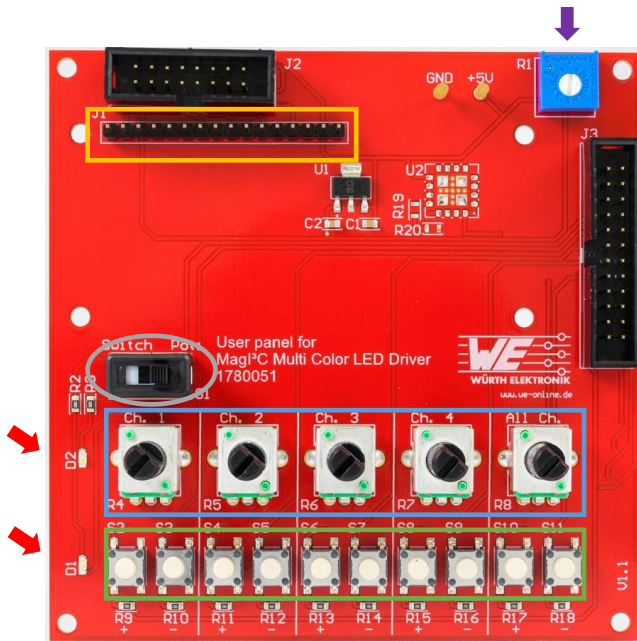

- Potentiometer for LCD contrast
- Possibility for an LCD to show dimming-ratio per channel
- Switch between potentiometer or button operation
- LED for indicating potentiometer or button operation
- Potentiometer for LED dimming
- Buttons for LED dimming

Figure 9: User panel

4.4 Horticulture LED Panel (example)

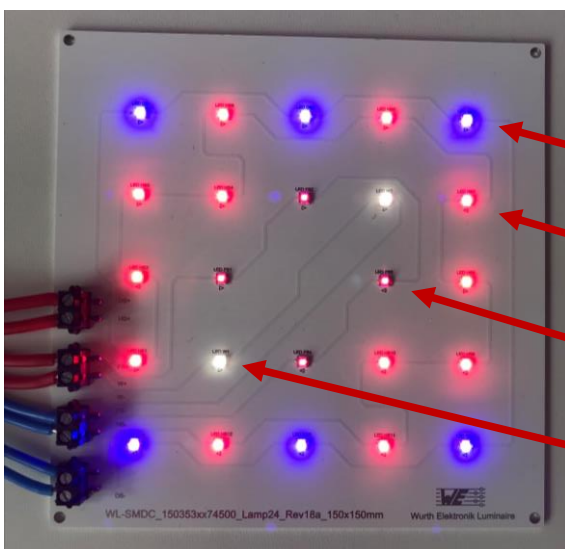

	No. of LEDs	Photosynthetic Photon Flux ¹ ($\mu\text{mol} \cdot \text{s}^{-1}$)	Photon Flux ¹ ($\mu\text{mol} \cdot \text{s}^{-1}$)
WL-SMDC Deep Blue 450 nm (150353DS74500)	6	13.84	14.16
WL-SMDC Hyper Red 660 nm (150353HS74500)	12	21.66	23.64
WL-SMDC Far Red 730 nm (150353FS74500)	4	0.52	7.16
WL-SMTC Warm White 3000 K (158353030)	2	2.92	3.42

Figure 10: Example of Horticulture LED Board

Reference Design Note

Magl³C Power Modules DNS005 Magl³C Multi Color LED Driver



5. Electromagnetic Interference (EMI)

5.1 Conducted Electromagnetic Interference

The conducted EMI is measured at the input of the board. The limit for this reference design is the norm EN55032/CISPR32. The measurement was done with a PWM duty cycle of 80%.

As you can see, the in the graph below, the measured interference is always minimum 20dB μ V below the limit.

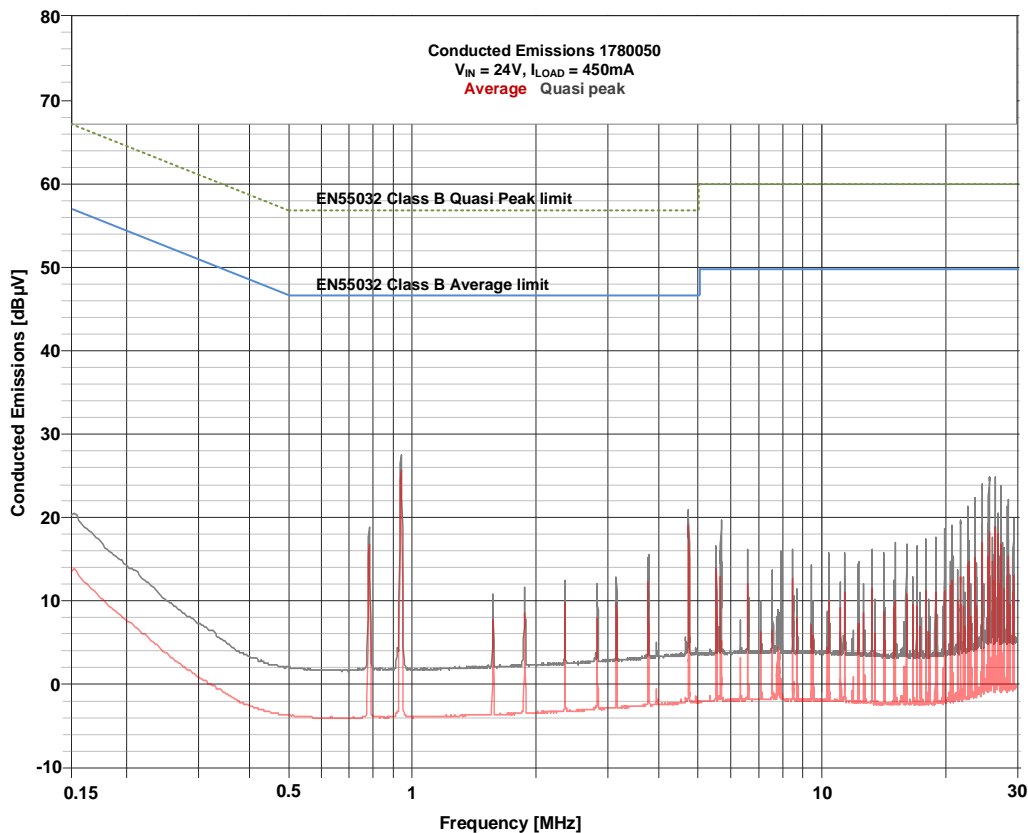

Figure 11: Conducted Emmissions 1780050

5.2 Radiated Electromagnetic Interference

The radiated EMI is measured in a Fully Anechoic Room (FAR) at 3m antenna distance. The limit for this reference design is the norm EN55015 - "Limits and methods of measurement of radio disturbance characteristics of electrical lighting and similar equipment". The measurement was done with PWM a duty cycle of 80%.

In the graph below shows, that the result of the measurement is also always minimum 26dB μ V/m lower than the limit.

Reference Design Note

Magl³C Power Modules DNS005 Magl³C Multi Color LED Driver

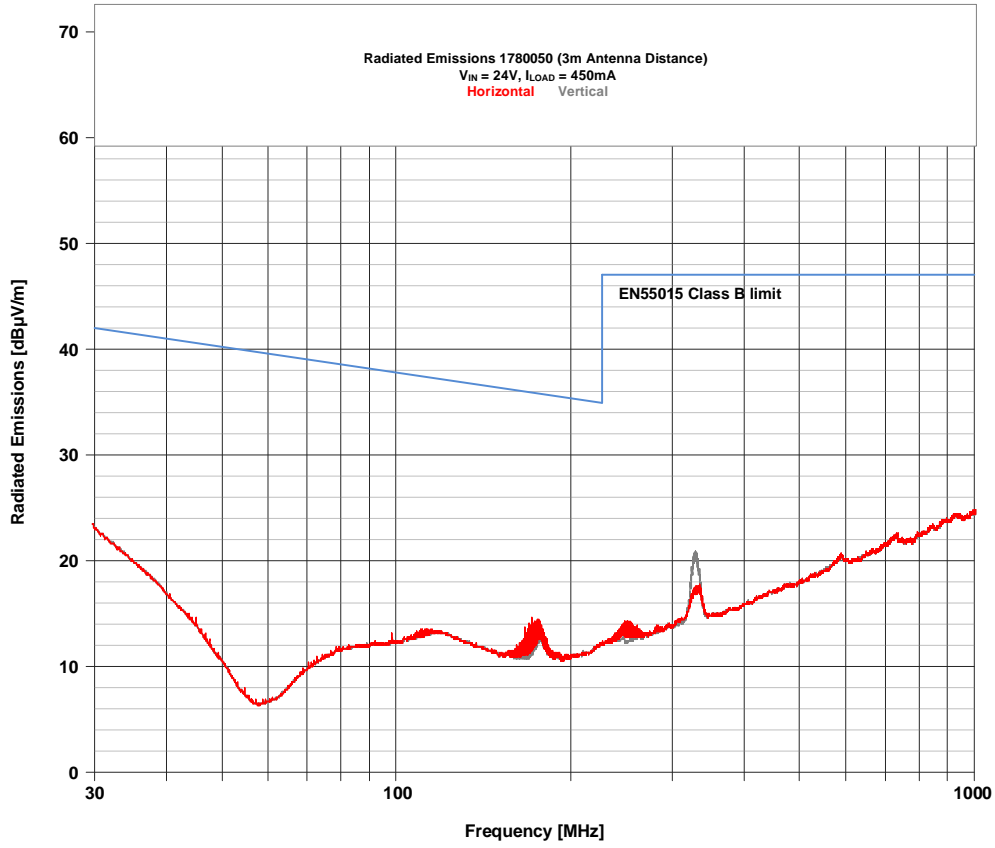

Figure 12: Radiated Emission with 3m antenna distance

Reference Design Note

MagI³C Power Modules DNS005 MagI³C Multi Color LED Driver



6. Getting started

6.1 With the User panel

First of all you need to connect the ribbon cable between the power board and the user panel. Use the connector “User panel”, “J2” and the 24-pin ribbon cable. Afterwards, connect your LED load board to the four channels of the power board. Set the Jumpers to the maximum output current you need. You can choose between 300mA, 350mA and 450mA. Recommended is the typical current of 350mA. Please set all four switches to “Off” to avoid a flickering of the LEDs while turning on. Set the switch on the User panel to the operation mode you want to use. If you use the potentiometers please note, that the LEDs will directly take the set values after setting the voltage switches. Now you can connect the power supply (between 18V and 48V) to the power board. Depending on the input voltage and the total forward voltage of the LED strings per channel, the switches for the input voltages of the LED drivers need to be chosen accordingly. If you have less than 6 LEDs, please set the switch to 15V. Otherwise, set the board to the supply input voltage. With the switch on the user panel, you can choose if you want to dim using the potentiometer or the digital buttons. Every channel has its own potentiometer/button. The last potentiometer/button limits the duty cycle of all channels simultaneously.

If you want to switch from use of potentiometers to buttons, the set value will be taken on. When switching from buttons to potentiometer, the value of the potentiometers will be set directly.

6.2 With the Bluetooth App

When controlling the board using the app, you will not need to connect the user panel. If you don't connect the app, the A/D converter of the microcontroller will use a random value for the PWM when the Bluetooth is not connected. This can result in noticeable flickering of the LEDs. Set the Jumpers to the maximum output current you need. You can choose between 300mA, 350mA and 450mA. Recommended is the typical current of 350mA. Now connect your LED load board to the four channels of the power board. Please set all four switches to “Off” to avoid a flickering of the LEDs while turning on. Now you can connect the power supply (between 18V and 48V). Depending on the input voltage and the total forward voltage of the LED strings per channel, the switches for the input voltages of the LED drivers need to be chosen accordingly. If you have less than six LEDs, please set the switch to 15V. Otherwise, set the switch to be directly powered by the supply input voltage. When everything is working you can connect the “WEIlluminate” app with the Bluetooth module on the power board. Click “Select Device” in the upper right corner of the app and connect it to the AMB2621 Module. Now you can adjust the PWM duty cycle with the sliders in the app.

6.3 Important Notes

Please note that the LED panel will flash up for a few milliseconds (typically about 50ms) due to the initialization of the microcontroller when turning on the power supply, if you do not set the switches to “Off” before turning on.

Also please never look directly into the LEDs, this can cause irreparable damage to the eye due to the brightness of the LEDs.

Reference Design Note

MagI³C Power Modules DNS005 MagI³C Multi Color LED Driver



7. Schematic

The schematic has been divided into three parts. The LED driver part was printed on two pages for a better overview of its complexity. The supply and microcontroller schematics are each printed on separate pages shown below.

The supply unit circuit begins with the input filter. After the input filter, the QFN-41 is placed with all its external components from the data sheet. Note that the SW pins are all connected together. The under voltage lockout voltage divider for the QFN-41 power module, realized with R3 and R6, is not placed. This option can be used, if a certain input voltage should be present before turn on or to ensure safe turn off of the output voltage in the event of an input voltage dip. The resistors R4 and R5 are used to adjust the output voltage to 15V and the switching frequency to 1MHz. The capacitor C2 enables the soft start of the module.

CE2, C3 and C4 are the input capacitors and C5 and C6 are the output capacitors of the QFN-41 power module. The minimum input voltage of the LED driver board is 18V to allow the 15V output voltage of the QFN-41 power module. The maximum input voltage is 48V.

The linear regulator is connected directly at the output of the QFN-41 power module. The microcontroller has a 100nF capacitor directly at each supply pin to avoid voltage spikes during operation. Furthermore, a Bluetooth Smart 4.2 module as well as a 16-pin ribbon connector for a Liquid Crystal Display (LCD) are implemented for ease of configuration and operation. A 24-pin ribbon connector allows the connection of the user panel to control the intensity. The 8-pin connector J5 allows synchronization of the four parallel LED drivers. On this additional board, no external power supply or control unit is needed as the supply voltages (V_{in} , 15V, 3.3V, GND), as well as the four PWM signals, are distributed via the 24-pin ribbon connector. The programmer is connected to the microcontroller via a six-pin connector (Prog.).

To decouple the LED drivers from each other, a PI-filter consisting of a 2.2 μ H PD2 coil (7447732110) and an electrolytic capacitor with 27 μ F (860040874001) is implemented at the input of each module. This provides damping of the noise and ripple generated by the switching frequency of the other modules.

The rest of the wiring of the LED driver was taken directly from the data sheet, with the exception of a polymer capacitor (875105945001) as an output capacitor. An output filter was also added, containing two chip bead ferrites with 1500Ohms at 100MHz (742792097) to damp high frequency noise in both lines. Also, a 100nF (885012207128) capacitor for damping high frequency voltages and a common mode choke (744226S) for low frequency noise damping is implemented.

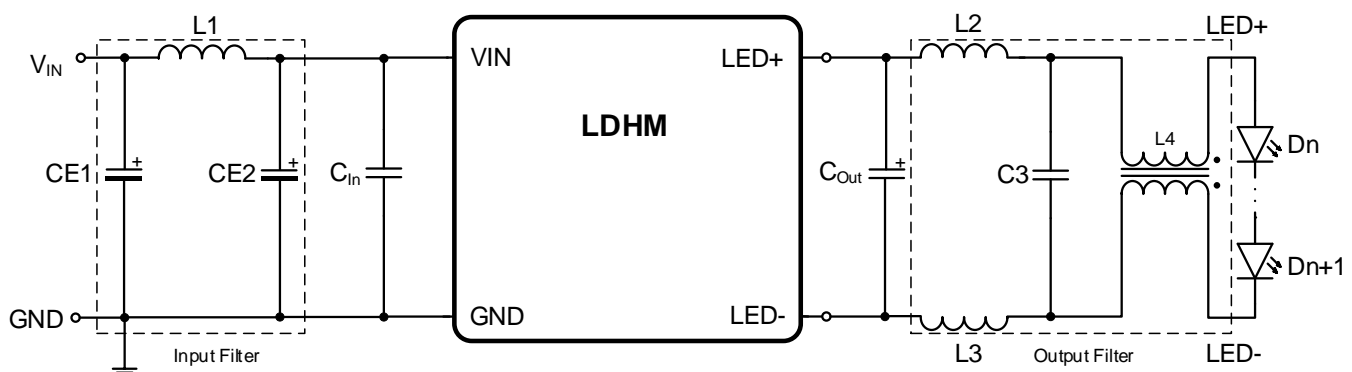

Figure 13: Single output channel including EMI Filter

Reference Design Note

Magi³C Power Modules DNS005 Magi³C Multi Color LED Driver

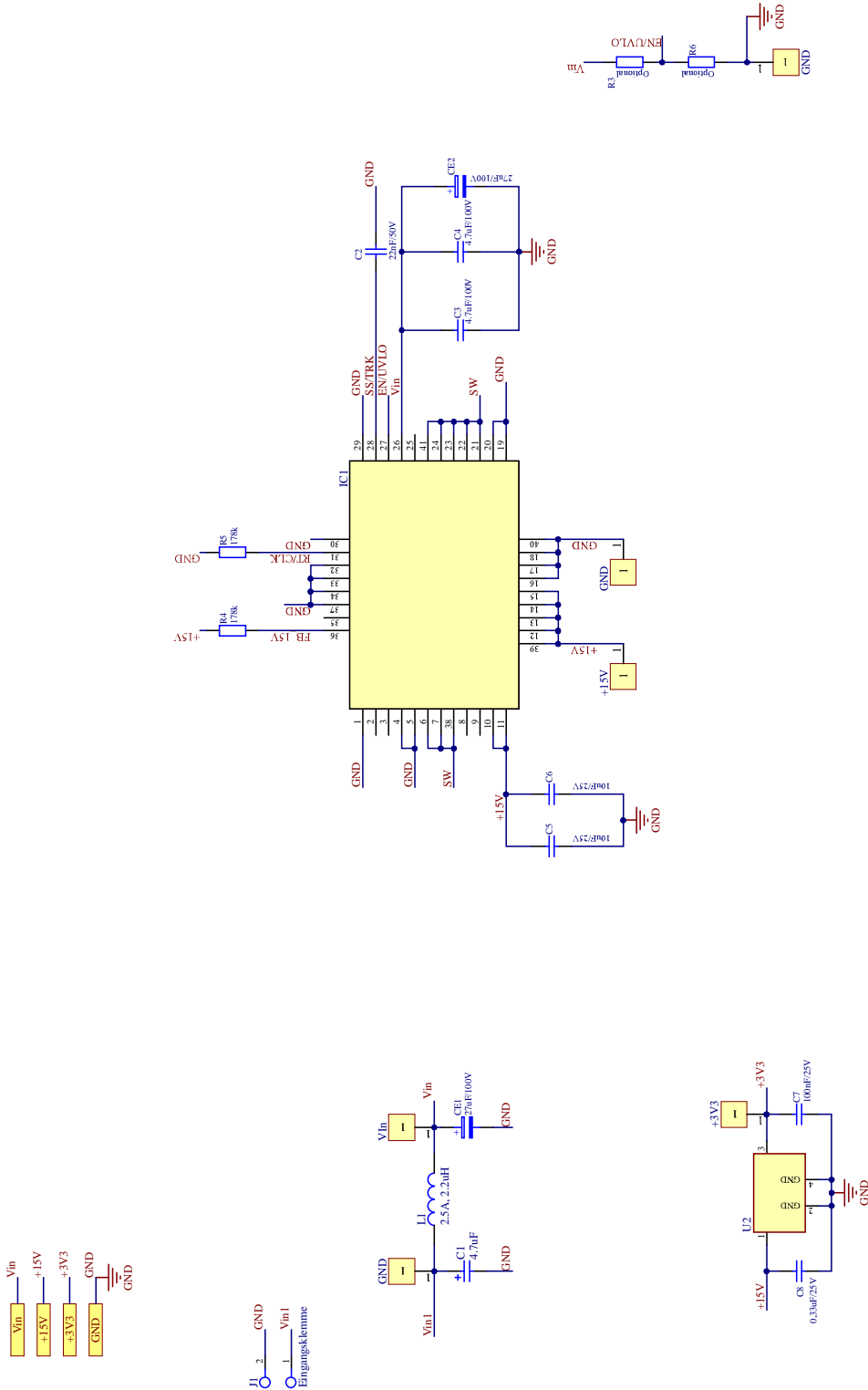

Figure 14: Multi Color Reference Design Schematic power supply

Reference Design Note

Magi³C Power Modules DNS005 Magi³C Multi Color LED Driver

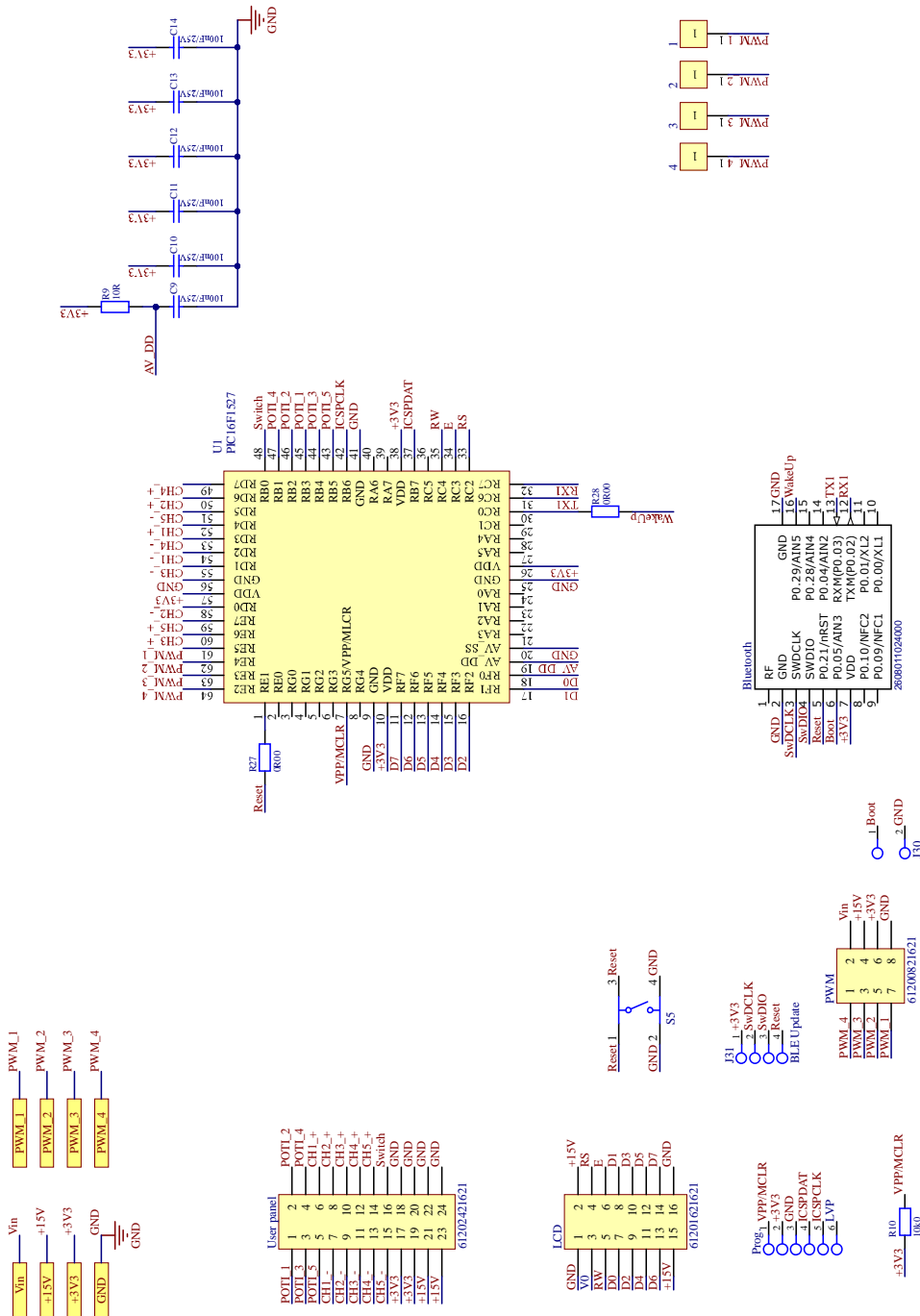

Figure 15: Multi Color Reference Design Schematic microcontroller

Reference Design Note

MagI³C Power Modules DNS005 MagI³C Multi Color LED Driver

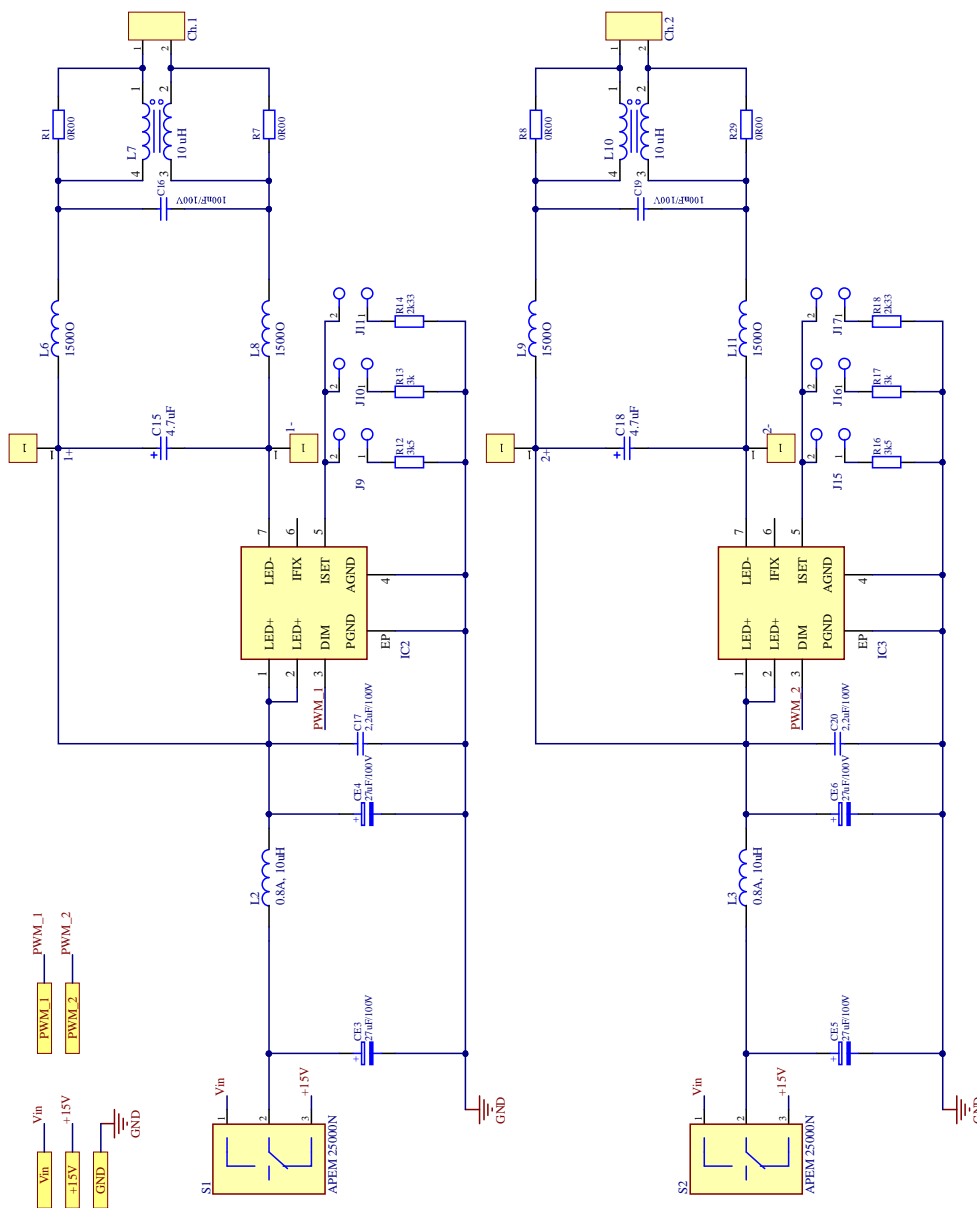

Figure 16: Multi Color Reference Design Schematic LED driver channel 1 and 2

Reference Design Note

MagI³C Power Modules DNS005 MagI³C Multi Color LED Driver

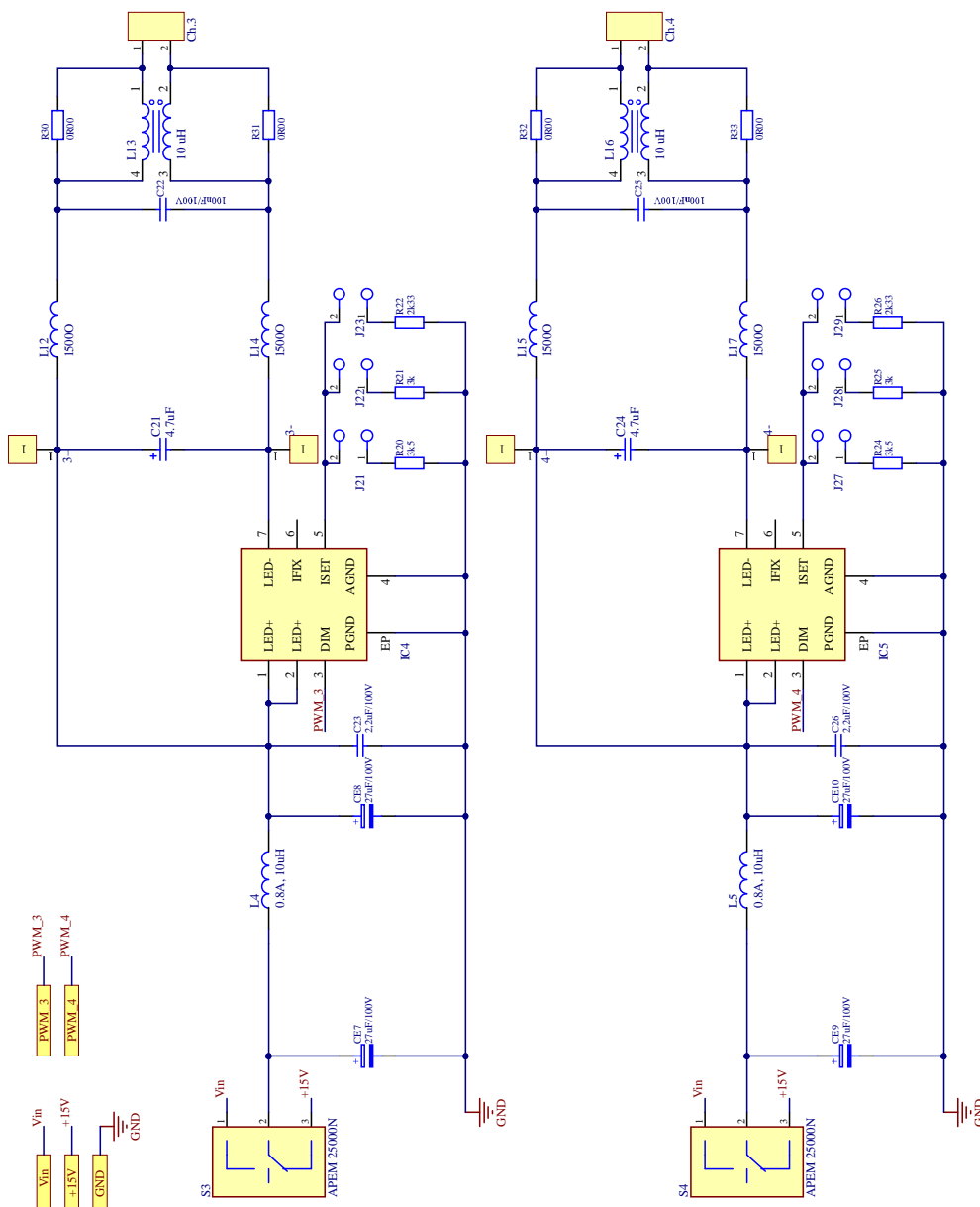

Figure 17: Multi Color Reference Design Schematic LED driver channel 3 and 4

Reference Design Note

MagI³C Power Modules DNS005 MagI³C Multi Color LED Driver



8. Assembly Drawing

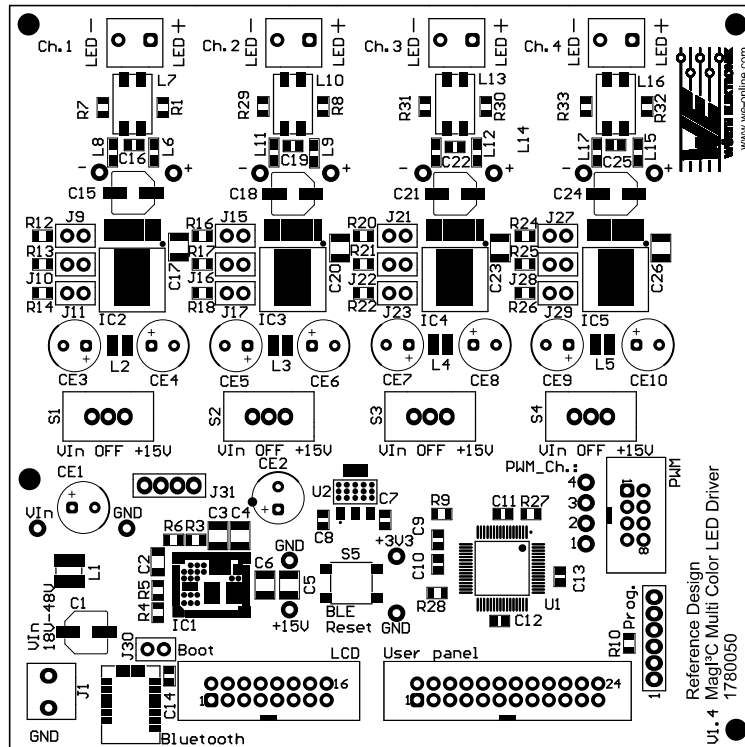

Figure 18: Multi Color Reference Design Assembly Drawing Power Board

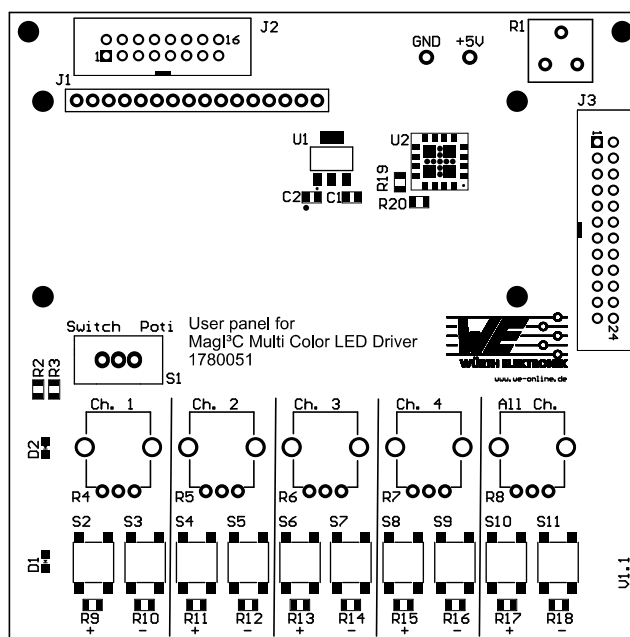

Figure 19: Multi Color Reference Design Assembly Drawing User panel

Reference Design Note

MagI³C Power Modules
DNS005 MagI³C Multi Color LED Driver

9. Bill of Material Power Board

Reference	Value	Package	Manufacturer	Order Code
-, +, +3V3, +15V, 1, 2, 3, 4, GND, VIn	not placed		Stelvio Kontek	3110325000500
Bluetooth	4.2 BLE T&R		Würth Elektronik	2608011024000
C1, C15, C18, C21, C24	4.7uF/100V	6.3x7.7mm	Würth Elektronik	875105945001
C2	22nF/50V	1206	Würth Elektronik	885012208083
C3, C4	4.7uF/100V	1206	TDK	KTS101B475M55N0T00
C5, C6	10uF/25V	1210	Würth Elektronik	885012209028
C7, C9, C10, C11, C12, C13, C14	100nF/25V	0805	Würth Elektronik	885012207072
C8	0,33uF/25V	0805	Würth Elektronik	885012207075
C16, C19, C22, C25	100nF/100V	0805	Würth Elektronik	885012207128
C17, C20, C23, C26	2,2uF/100V	1206	TDK	C3216X7S2A225K160AB
CE1, CE2, CE3, CE4, CE5, CE6, CE7, CE8, CE9, CE10	27uF/100V	8x11.5mm	Würth Elektronik	860040874001
IC1	7-50 Vin, 2.5-15 Vout, 2.5 A	BQFN-41	Würth Elektronik	171021501
IC2, IC3, IC4, IC5	4,5-60 Vin, Iout,max 450mA	TO-263	Würth Elektronik	172946001
J1, Ch.1, Ch.2, Ch.3, Ch.4		WR-TBL_5,0mm	Würth Elektronik	691502710002
User panel		24-pol.	Würth Elektronik	61202421621
LCD		16-pol.	Würth Elektronik	61201621621
Prog.		6-pol.	Würth Elektronik	61300611121
PWM		8-pol.	Würth Elektronik	61200821621
J9, J10, J11, J15, J16, J17, J21, J22, J23, J27, J28, J29, J30		2-pol.	Würth Elektronik	61300211121
J31		4-pol.	Würth Elektronik	61300411121
L1	2.5A, 2.2uH	4532	Würth Elektronik	744773022
L2, L3, L4, L5	0.8A, 10uH	3521	Würth Elektronik	7447732110
L6, L8, L9, L11, L12, L14, L15, L17	1500Ω	0805	Würth Elektronik	742792097
L7, L10, L13, L16	10 uH	SMD	Würth Elektronik	744226S
R27, R28	0R	0805	Vishay	CRCW08050000Z0EBC
R3, R6, R30, R31, R32, R33, R1, R7, R8, R29	not placed, 0R	0805	Vishay	CRCW08050000Z0EBC
R4, R5	178k	0805	Panasonic	ERJ-6ENF1783V
R9	10R	0805	Vishay	CRCW080510R0FKEAC
R10	10k0	0805	Vishay	CRCW0805-10K
R12, R16, R20, R24	3k48	0805	Panasonic	ERJ-6ENF3481V
R13, R17, R21, R25	3k	0805	Panasonic	ERJ-6ENF3001V
R14, R18, R22, R26	2k32	0805	Panasonic	ERJ-6ENF2321V
S1, S2, S3, S4		3-pol.	APEM	25139NAH
S5		6x6x5mm SMD	Würth Elektronik	430152050826
U1	PIC16F1527	TQFP-64	Microchip	PIC16F1527-I/PT
U2	3V3 500mA	SOT-223-4	Texas Instruments	UA78M33CDCYR
Pad1, Pad2, Pad3, Pad4		Rubber Pad	3M	SJ5076BLACK
PCB1	1780050	115x115mm, 4 Layers	Würth Elektronik	L-1780050
Jumper	placed on J10, J16, J22, J28		Würth Elektronik	60900213421

Reference Design Note

MagI³C Power Modules DNS005 MagI³C Multi Color LED Driver



10. Bill of Material User Panel

Reference	Value	Package	Manufacturer	Order Code
+V, GND	not placed		Stelvio Kontek	3110325000500
C1	100nF/25V	0805	Würth Elektronik	885012207072
C2	0,33uF/25V	0805	Würth Elektronik	885012207075
D1, D2	Red, 2V, 140°	0805	Würth Elektronik	150080RS75000
J1		16-pol	Würth Elektronik	61301611121
J2		16-pol	Würth Elektronik	61201621621
J3		24-pol	Würth Elektronik	61202421621
R1	10k	THT	Bourns	3386F-1-103LF
R2, R3	100R	0805	Vishay	CRCW0805-100
R4, R5, R6, R7, R8	5k	THT	Bourns	PTV09A-4020F-B502
R9, R10, R11, R12, R13, R14, R15, R16, R17, R18	10k	0805	Vishay	CRCW0805-10K
S1		2-pol.	APEM	25136NAH
S2, S3, S4, S5, S6, S7, S8, S9, S10, S11		6x6x5mm SMD	Würth Elektronik	430152050826
U1	5V, 500mA	SOT-223-4	Texas Instruments	uA78M05CDYR
R19, R20	Not placed			
Pad1, Pad2, Pad3, Pad4		Rubber Pad	3M	SJ5076BLACK
LCD Display Modul with HD44780 controller	Can be placed on J1	1602		
PCB1		100x100mm, 2 Layers	Würth Elektronik	L-1780051

Reference Design Note

MagI³C Power Modules DNS005 MagI³C Multi Color LED Driver



11. Important Notes

This Reference Design Note / Application Note is based on our knowledge and experience of typical requirements concerning these areas. It serves as general guidance and should not be construed as a commitment for the suitability for customer applications by Würth Elektronik eiSos GmbH & Co. KG. The information in the Application Note is subject to change without notice. This document and parts thereof must not be reproduced or copied without written permission, and contents thereof must not be imparted to a third party nor be used for any unauthorized purpose.

Würth Elektronik eiSos GmbH & Co. KG and its subsidiaries and affiliates (WE) are not liable for application assistance of any kind. Customers may use WE's assistance and product recommendations for their applications and design. The responsibility for the applicability and use of WE Products in a particular customer design is always solely within the authority of the customer. Due to this fact it is up to the customer to evaluate and investigate, where appropriate, and decide whether the device with the specific product characteristics described in the product specification is valid and suitable for the respective customer application or not.

The technical specifications are stated in the current data sheet of the products. Therefore the customers shall use the data sheets and are cautioned to verify that data sheets are current. The current data sheets can be downloaded at www.we-online.com. Customers shall strictly observe any product-specific notes, cautions and warnings. WE reserves the right to make corrections, modifications, enhancements, improvements, and other changes to its products and services.

WE DOES NOT WARRANT OR REPRESENT THAT ANY LICENSE, EITHER EXPRESS OR IMPLIED, IS GRANTED UNDER ANY PATENT RIGHT, COPYRIGHT, MASK WORK RIGHT, OR OTHER INTELLECTUAL PROPERTY RIGHT RELATING TO ANY COMBINATION, MACHINE, OR PROCESS IN WHICH WE PRODUCTS OR SERVICES ARE USED. INFORMATION PUBLISHED BY WE REGARDING THIRD-PARTY PRODUCTS OR SERVICES DOES NOT CONSTITUTE A LICENSE FROM WE TO USE SUCH PRODUCTS OR SERVICES OR A WARRANTY OR ENDORSEMENT THEREOF.

WE products are not authorized for use in safety-critical applications, or where a failure of the product is reasonably expected to cause severe personal injury or death. Moreover, WE products are neither designed nor intended for use in areas such as military, aerospace, aviation, nuclear control, submarine, transportation (automotive control, train control, ship control), transportation signal, disaster prevention, medical, public information network etc. Customers shall inform WE about the intent of such usage before design-in stage. In certain customer applications requiring a very high level of safety and in which the malfunction or failure of an electronic component could endanger human life or health, customers must ensure that they have all necessary expertise in the safety and regulatory ramifications of their applications. Customers acknowledge and agree that they are solely responsible for all legal, regulatory and safety-related requirements concerning their products and any use of WE products in such safety-critical applications, notwithstanding any applications-related information or support that may be provided by WE. CUSTOMERS SHALL INDEMNIFY WE AGAINST ANY DAMAGES ARISING OUT OF THE USE OF WE PRODUCTS IN SUCH SAFETY-CRITICAL APPLICATIONS.

USEFUL LINKS

Application Notes / Reference Design Notes
<https://www.we-online.com/app-notes>

REDEXPERT Design Tool
<https://www.we-online.com/redexpert>

Toolbox
<https://www.we-online.com/toolbox>

MagI³C Product Catalog
<https://katalog.we-online.com/en/pm>

CONTACT INFORMATION

Technical Support
powermodules@we-online.com

Würth Elektronik eiSos GmbH & CO. KG
Max-Eyth-Str. 1, 74638 Waldenburg
Germany

Tel.: +49 7942 945 0
we-online.com