

# High Isolation Power Transformers

EP7 Platform SMD - PH9185.XXXNL and PM2190.XXXNL



- Push Pull Transformer
- Reinforced insulation for isolated power supply driver
- 8mm creepage
- 5KVrms isolation (1000Vrms continuous)<sup>1</sup>
- UL and TUV certified

## Electrical Specifications @ 25°C - Operating Temperature -40°C to +125°C

Part Number		Inductance (1-3)	Leakage Inductance	DCR (1-3)	DCR (4-6)	ET MAX (1-3) <sup>1</sup>	CAP	Turns Ratio	Isolated Voltage <sup>4</sup>
Commercial	Automotive <sup>8</sup>	( $\mu\text{H} \pm 45\%$ )	( $\mu\text{H MAX}$ )	( $\Omega \text{ MAX}$ )	( $\Omega \text{ MAX}$ )	(V- $\mu\text{sec MAX}$ )	(pF MAX)	(1:3) (6:4)	(Vrms)
PH9185.011NL	PM2190.011NL	750	1.2	0.50	0.55	66	10.0	1CT : 1CT	5000
PH9185.012NL	PM2190.012NL	450	0.9	0.40	0.80	52	10.0	1CT : 2CT	
PH9185.013NL	PM2190.013NL	200	0.6	0.35	0.95	36	8.0	1CT : 3CT	
PH9185.021NL	PM2190.021NL	1800	3.0	0.75	0.45	100	10.0	2CT : 1CT	
PH9185.034NL	PM2190.034NL	750	1.2	0.50	0.75	66	10.0	3CT : 4CT	
PH9185.038NL	PM2190.038NL	310	0.9	0.44	1.00	44	8.0	3CT : 8CT	
PH9185.043NL	PM2190.043NL	1260	1.5	0.70	0.56	89	12.0	4CT : 3CT	
PH9185.083NL	PM2190.083NL	2350	6.0	0.90	0.40	110	8.0	8CT : 3CT	

### Notes:

- The ET Max is calculated to limit the core loss and temperature rise at 100KHz based on a bipolar flux swing of 180mT Peak.
- For Push-Pull topology, where the voltage is applied across half the primary winding turns, the ET needs to be derated by 50% for the same flux swing.
- The applied ET may need to be further derated for higher frequencies based on the temperature rise which results from the core and copper losses
  - To calculate total copper loss (W), use the following formula:  

$$\text{Copper Loss (W)} = \text{Irms\_Primary}^2 * \text{DCR\_Primary} + \text{Irms\_Secondary}^2 * \text{DCR\_Secondary}$$
  - To calculate total core loss (W), use the following formula:  

$$\text{Core Loss (W)} = 4.40\text{E-}10 * (\text{Frequency in kHz})^{1.67} * (180 * [\text{ET}/\text{ET Max}])^{2.55}$$
 Where ET is the applied Volt Second, ET Max is the rated Volt Second for 180mT flux swing
  - To calculate temperature rise, use the following formula:  $\text{Temperature Rise } (^\circ\text{C}) = 90 * (\text{Core Loss (W)} + \text{Copper Loss (W)})$
- The AEC-Q200 temperature and humidity operational life testing was completed using a dielectric strength test of 5000Vdc.
- Optional Tape & Reel packing can be ordered by adding a "T" suffix to the part number (i.e. PH9185.012NL becomes PH9185.012NLT). Pulse complies to industry standard tape and reel specification EIA481.
- The "NL" suffix indicates an RoHS-compliant part number.
- Continuous isolation voltage confirmed by 125°C/1000hrs accelerated aging with the bias voltage applied between primary and secondary windings.
- The PM2190.XXXNL part numbers are AEC-Q200 and IATF16949 certified.
- Special Characteristics

## Mechanical

## Schematic

### PH9185.XXXNL/PM2190.XXXNL

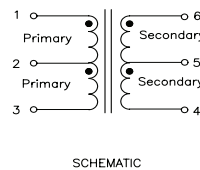
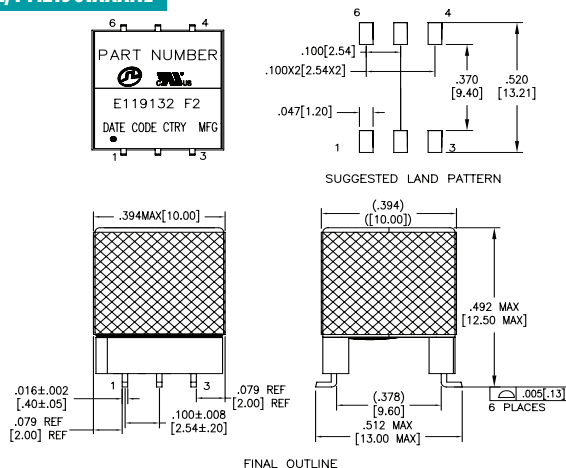

**Weight** .....2.6grams  
**Tape & Reel** .....150/reel  
**Tray** .....80/tray

**Dimensions:** Inches  
 mm

Unless otherwise specified,  
 all tolerances are  $\pm \frac{.010}{0.25}$

# High Isolation Power Transformers

EP7 Platform SMD - PH9185.XXXNL and PM2190.XXXNL

## TAPE & REEL INFO

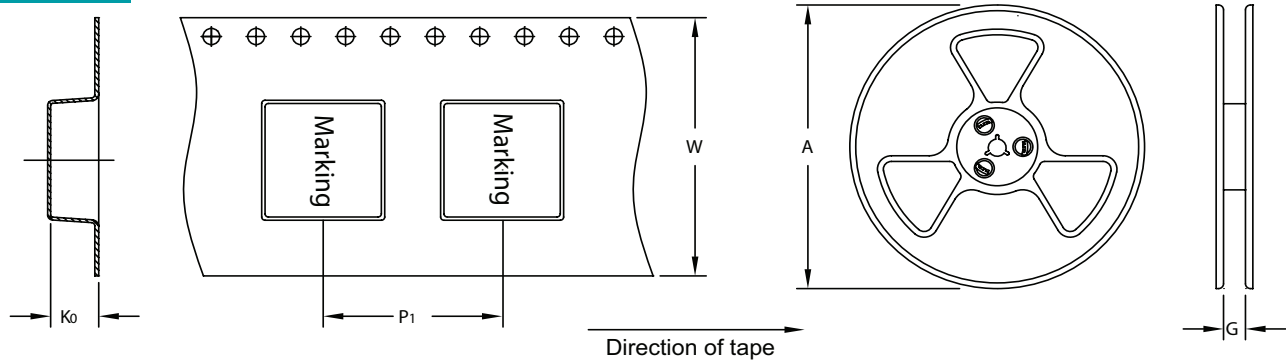

SURFACE MOUNTING TYPE, REEL/TAPE LIST

PART NUMBER	REEL SIZE (mm)		TAPE SIZE (mm)			QTY
	A	G	P <sub>1</sub>	W	K <sub>0</sub>	PCS/REEL
PH9185.XXXNL/PM2190.XXXNL	Ø330	32.4	24	32	12.8	150

## APPLICATION

PH9185.XXXNL is a series of high isolation power supply transformer drivers. Intended to operate in a fixed duty cycle Push Pull topology, it is a part of a low cost solution for delivering lower power (up to 3W) from a low voltage source. A typical implementation would be an isolated RS-485/RS-232 power supply driver circuit, the design is compatible with the MAXIM™ MAX253 IC.

A schematic diagram for the Push Pull converter topology is given below.

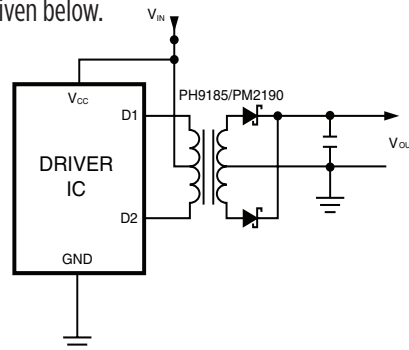

For a fixed 50% duty cycle mode of operation, the output voltage is simply determined by the input voltage and turns ratio. So, with the available turns ratios, a variety of output voltages can be selected.

This transformer design has been certified by UL to comply with UL60950-1 2<sup>nd</sup> edition, and CAN/CSA C22.2 NO. 60950-1-07 2<sup>nd</sup> edition; and by TUV to comply with EN61558-1 and EN61558-2-16 with reinforced insulation for a working voltage up to 400Vac 8mm creepage and 5000Vrms isolation voltage is guaranteed to meet this requirement. The design also complies with the Pulse's class F insulation system. PH9185.013NL was not included in the original UL/TUV certification but is compliant. Cost reduced versions without UL/TUV certification available, please contact Pulse Electronics for more information.

MAXIM is a registered trademark of Maxim Integrated Products.

## For More Information

### Pulse Worldwide Headquarters

15255 Innovation Drive Ste 100  
San Diego, CA 92128  
U.S.A.

### Pulse Europe

Pulse Electronics GmbH  
Am Rottland 12  
58540 Meinerzhagen  
Germany

### Pulse China Headquarters

Pulse Electronics (ShenZhen) CO., LTD  
D708, Shenzhen Academy of  
Aerospace Technology,  
The 10th Keji South Road,  
Nanshan District, Shenzhen,  
P.R. China 518057

### Pulse North China

Room 2704/2705  
Super Ocean Finance Ctr.  
2067 Yan An Road West  
Shanghai 200336  
China

### Pulse South Asia

3 Fraser Street  
0428 DUO Tower  
Singapore 189352

### Pulse North Asia

1F., No.111 Xiyuan Rd  
Zhongli City  
Taoyuan City 32057  
Taiwan (R.O.C)

Tel: 858 674 8100  
Fax: 858 674 8262

Tel: 49 2354 777 100  
Fax: 49 2354 777 168

Tel: 86 755 33966678  
Fax: 86 755 33966700

Tel: 86 21 62787060  
Fax: 86 2162786973

Tel: 65 6287 8998  
Fax: 65 6280 0080

Tel: 886 3 4356768  
Fax: 886 3 4356820

Performance warranty of products offered on this data sheet is limited to the parameters specified. Data is subject to change without notice. Other brand and product names mentioned herein may be trademarks or registered trademarks of their respective owners. © Copyright, 2020. Pulse Electronics, Inc. All rights reserved.