



# PD85015-E PD85015S-E

## RF power transistor, LdmoST plastic family N-channel enhancement-mode lateral MOSFETs

### Features

- Excellent thermal stability
- Common source configuration
- $P_{OUT} = 15\text{ W}$  with 16 dB gain @ 870 MHz / 13.6 V
- Plastic package
- ESD protection
- In compliance with the 2002/95/EC european directive

### Description

The PD85015-E is a common source N-channel, enhancement-mode lateral field-effect RF power transistor. It is designed for high gain, broadband commercial and industrial applications. It operates at 13.6 V in common source mode at frequencies of up to 1 GHz. PD85015-E boasts the excellent gain, linearity and reliability of ST's latest LDMOS technology mounted in the first true SMD plastic RF power package, PowerSO-10RF. PD85015-E's superior linearity performance makes it an ideal solution for car mobile radio. The PowerSO-10 plastic package, designed to offer high reliability, is the first ST JEDEC approved, high power SMD package. It has been specially optimized for RF needs and offers excellent RF performances and ease of assembly. Mounting recommendations are available in [www.st.com/rf](http://www.st.com/rf) (search for AN1294)

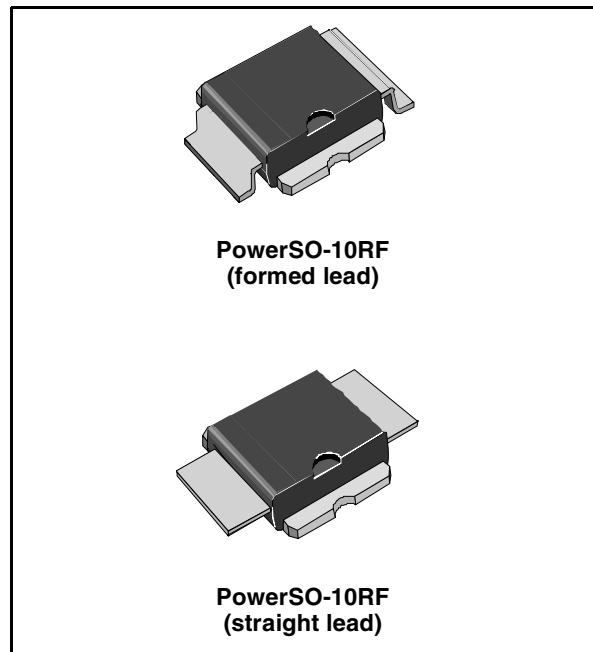

Figure 1. Pin connection

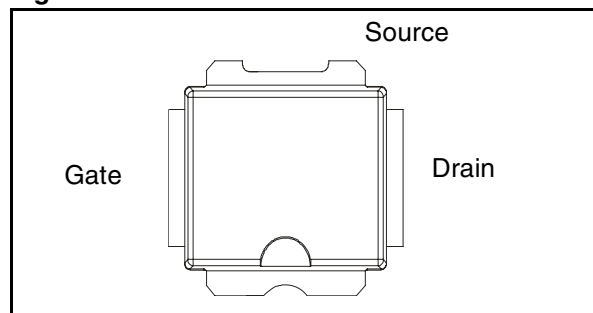

Table 1. Device summary

Order codes	Package	Packaging
PD85015-E	PowerSO-10RF (formed lead)	Tube
PD85015S-E	PowerSO-10RF (straight lead)	Tube
PD85015TR-E	PowerSO-10RF (formed lead)	Tape and reel
PD85015STR-E	PowerSO-10RF (straight lead)	Tape and reel

# Contents

<b>1</b>	<b>Electrical data</b> .....	<b>3</b>
1.1	Maximum ratings .....	3
1.2	Thermal data .....	3
<b>2</b>	<b>Electrical characteristics</b> .....	<b>4</b>
2.1	Static .....	4
2.2	Dynamic .....	4
2.3	ESD protection characteristics .....	4
<b>3</b>	<b>Impedance</b> .....	<b>5</b>
<b>4</b>	<b>Typical performances</b> .....	<b>6</b>
<b>5</b>	<b>Package mechanical data</b> .....	<b>7</b>
<b>6</b>	<b>Revision history</b> .....	<b>12</b>

# 1 Electrical data

## 1.1 Maximum ratings

**Table 2. Absolute maximum ratings ( $T_{CASE} = 25\text{ °C}$ )**

Symbol	Parameter	Value	Unit
$V_{(BR)DSS}$	Drain-source voltage	40	V
$V_{GS}$	Gate-source voltage	-0.5 to +15	V
$I_D$	Drain current	5	A
$P_{DISS}$	Power dissipation (@ $T_C = 70\text{ °C}$ )	59	W
$T_J$	Max. operating junction temperature	165	°C
$T_{STG}$	Storage temperature	-65 to +150	°C

## 1.2 Thermal data

**Table 3. Thermal data**

Symbol	Parameter	Value	Unit
$R_{thJC}$	Junction - case thermal resistance	1.6	°C/W

## 2 Electrical characteristics

$$T_{\text{CASE}} = +25 \text{ }^{\circ}\text{C}$$

### 2.1 Static

Table 4. Static

Symbol	Test conditions		Min	Typ	Max	Unit
$I_{\text{DSS}}$	$V_{\text{GS}} = 0\text{V}$	$V_{\text{DS}} = 25\text{V}$	-		1	$\mu\text{A}$
$I_{\text{GSS}}$	$V_{\text{GS}} = 5\text{V}$	$V_{\text{DS}} = 0\text{V}$			1	$\mu\text{A}$
$V_{\text{GS(Q)}}$	$V_{\text{DS}} = 10\text{V}$	$I_{\text{D}} = 150\text{mA}$			3.4	V
$V_{\text{DS(ON)}}$	$V_{\text{GS}} = 10\text{V}$	$I_{\text{D}} = 1\text{A}$			0.34	V
$C_{\text{ISS}}$	$V_{\text{GS}} = 0\text{V}$	$V_{\text{DS}} = 12.5\text{V}$			45	pF
$C_{\text{OSS}}$	$V_{\text{GS}} = 0\text{V}$	$V_{\text{DS}} = 12.5\text{V}$			36	pF
$C_{\text{RSS}}$	$V_{\text{GS}} = 0\text{V}$	$V_{\text{DS}} = 12.5\text{V}$			1.2	pF

### 2.2 Dynamic

Table 5. Dynamic

Symbol	Test conditions		Min	Typ	Max	Unit
P3dB	$V_{\text{DD}} = 13.6\text{V}$ , $I_{\text{DQ}} = 150\text{mA}$	$f = 870\text{MHz}$	15	20	-	W
$G_{\text{P}}$	$V_{\text{DD}} = 13.6\text{V}$ , $I_{\text{DQ}} = 150\text{mA}$ , $P_{\text{OUT}} = 15\text{W}$ , $f = 870\text{MHz}$		16			dB
$h_{\text{D}}$	$V_{\text{DD}} = 13.6\text{V}$ , $I_{\text{DQ}} = 150\text{mA}$ , $P_{\text{OUT}} = \text{P3dB}$ , $f = 870\text{MHz}$		60	70		%
Load mismatch	$V_{\text{DD}} = 1.7\text{V}$ , $I_{\text{DQ}} = 300\text{mA}$ , $P_{\text{OUT}} = 25\text{W}$ , $f = 870\text{MHz}$ All phase angles		20:1			VSWR

### 2.3 ESD protection characteristics

Table 6. ESD protection characteristics

Test conditions		Class
Human body model		2
Machine model		M3

### 3 Impedance

Figure 2. Current conventions

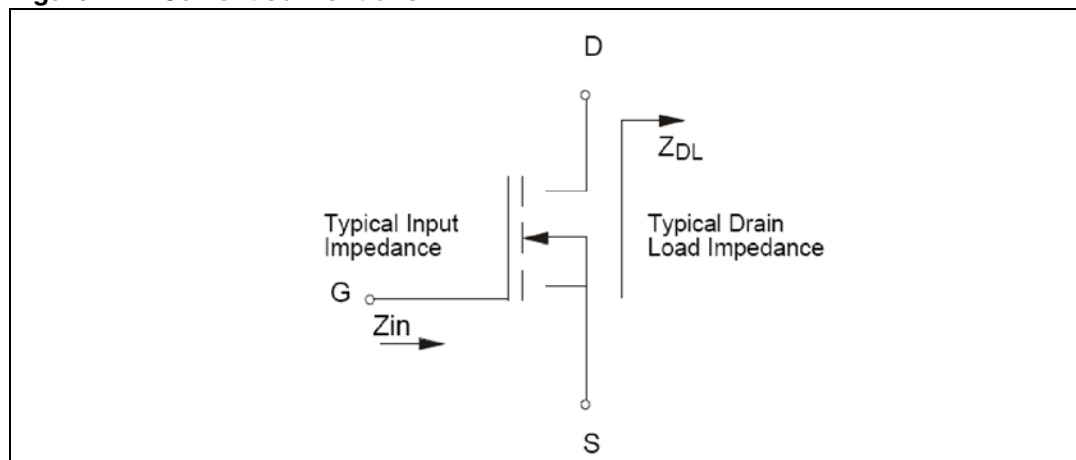
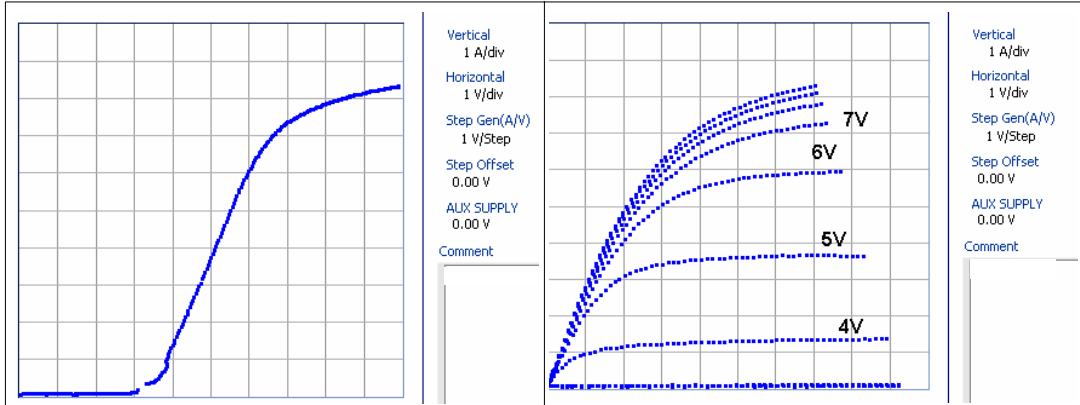

Table 7. Impedance data

Frequency (MHz)	$Z_{IN} (\Omega)$	$Z_{DL} (\Omega)$
870 MHz	TBD	TBD

# 4 Typical performances

**Figure 3. Drain current vs gate voltage**      **Figure 4. DC output characteristics**



**Figure 5. Capacitances vs drain voltage**

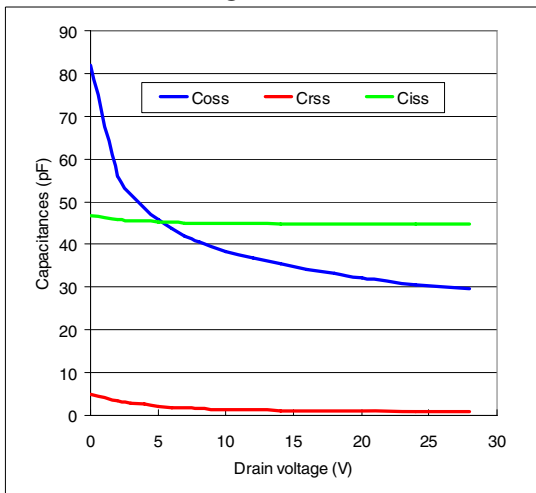

## 5 Package mechanical data

In order to meet environmental requirements, ST offers these devices in different grades of ECOPACK<sup>®</sup> packages, depending on their level of environmental compliance. ECOPACK<sup>®</sup> specifications, grade definitions and product status are available at: [www.st.com](http://www.st.com). ECOPACK<sup>®</sup> is an ST trademark.

**Table 8. PowerSO-10RF formed lead (gull wing) mechanical data**

Dim.	mm.			Inch		
	Min	Typ	Max	Min	Typ	Max
A1	0	0.05	0.1	0.	0.0019	0.0038
A2	3.4	3.5	3.6	0.134	0.137	0.142
A3	1.2	1.3	1.4	0.046	0.05	0.054
A4	0.15	0.2	0.25	0.005	0.007	0.009
a		0.2			0.007	
b	5.4	5.53	5.65	0.212	0.217	0.221
c	0.23	0.27	0.32	0.008	0.01	0.012
D	9.4	9.5	9.6	0.370	0.374	0.377
D1	7.4	7.5	7.6	0.290	0.295	0.298
E	13.85	14.1	14.35	0.544	0.555	0.565
E1	9.3	9.4	9.5	0.365	0.37	0.375
E2	7.3	7.4	7.5	0.286	0.292	0.294
E3	5.9	6.1	6.3	0.231	0.24	0.247
F		0.5			0.019	
G		1.2			0.047	
L	0.8	1	1.1	0.030	0.039	0.042
R1			0.25			0.01
R2		0.8			0.031	
T	2 deg	5 deg	8 deg	2 deg	5 deg	8 deg
T1		6 deg			6 deg	
T2		10 deg			10 deg	

Note: Resin protrusions not included (max value: 0.15 mm per side)

**Figure 6. Package dimensions**

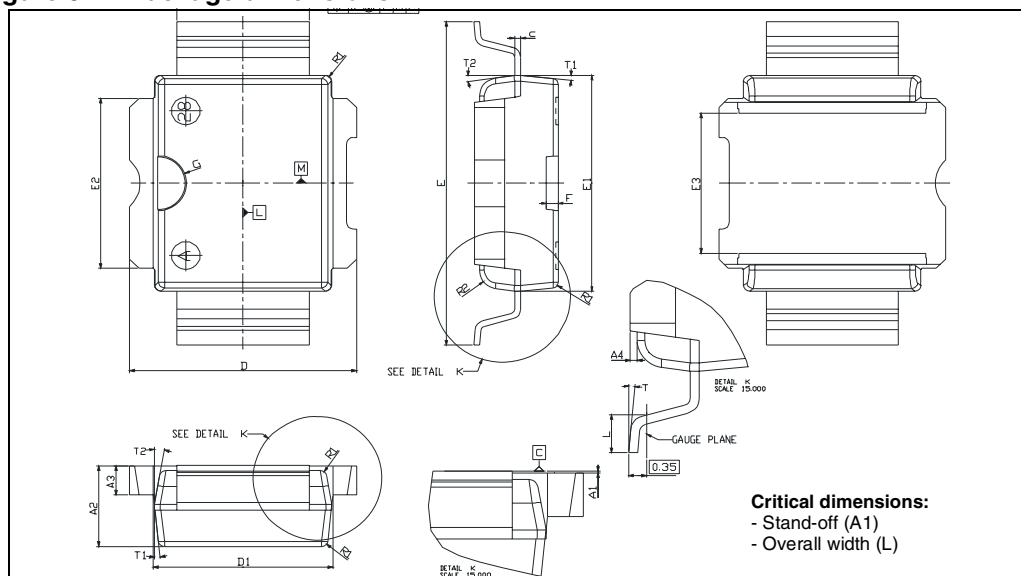



**Table 9. PowerSO-10RF straight lead mechanical data**

Dim.	mm.			Inch		
	Min	Typ	Max	Min	Typ	Max
A1	1.62	1.67	1.72	0.064	0.065	0.068
A2	3.4	3.5	3.6	0.134	0.137	0.142
A3	1.2	1.3	1.4	0.046	0.05	0.054
A4	0.15	0.2	0.25	0.005	0.007	0.009
a		0.2			0.007	
b	5.4	5.53	5.65	0.212	0.217	0.221
c	0.23	0.27	0.32	0.008	0.01	0.012
D	9.4	9.5	9.6	0.370	0.374	0.377
D1	7.4	7.5	7.6	0.290	0.295	0.298
E	15.15	15.4	15.65	0.595	0.606	0.615
E1	9.3	9.4	9.5	0.365	0.37	0.375
E2	7.3	7.4	7.5	0.286	0.292	0.294
E3	5.9	6.1	6.3	0.231	0.24	0.247
F		0.5			0.019	
G		1.2			0.047	
R1			0.25			0.01
R2		0.8			0.031	
T1		6 deg			6 deg	
T2		10 deg			10 deg	

*Note: Resin protrusions not included (max value: 0.15 mm per side)*

**Figure 7. Package dimensions**

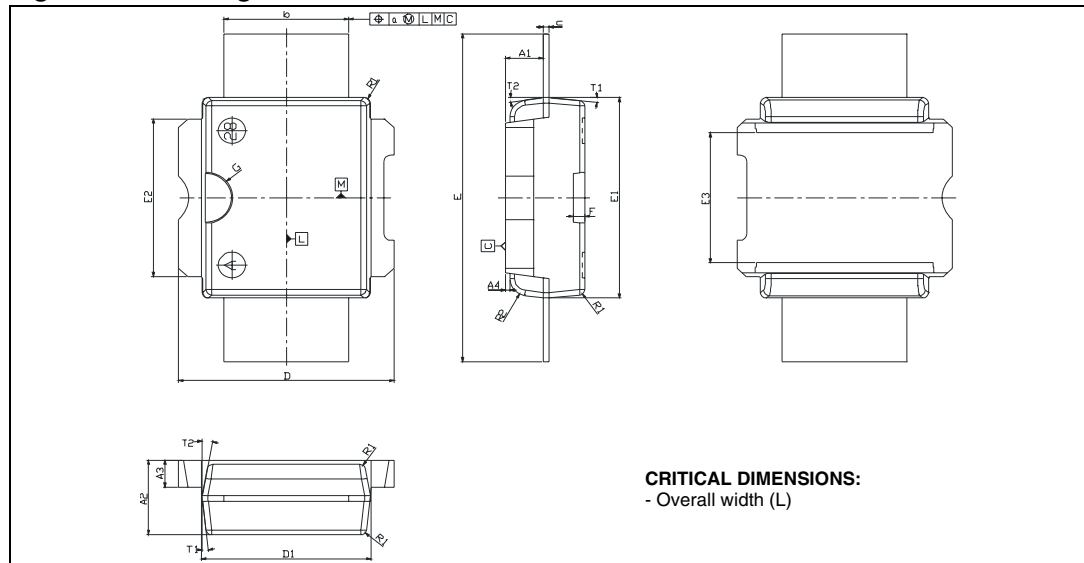

Figure 8. Tube information

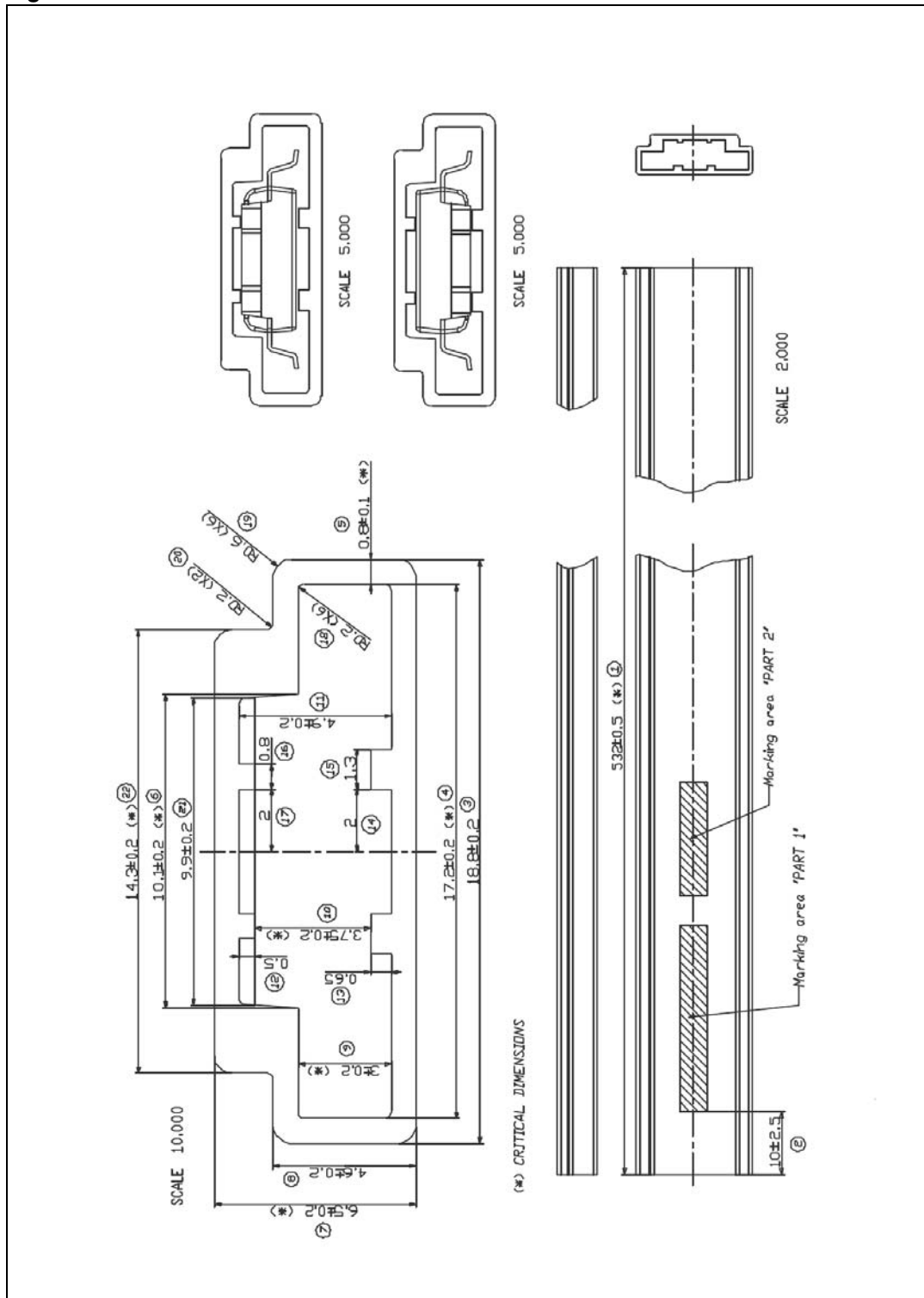
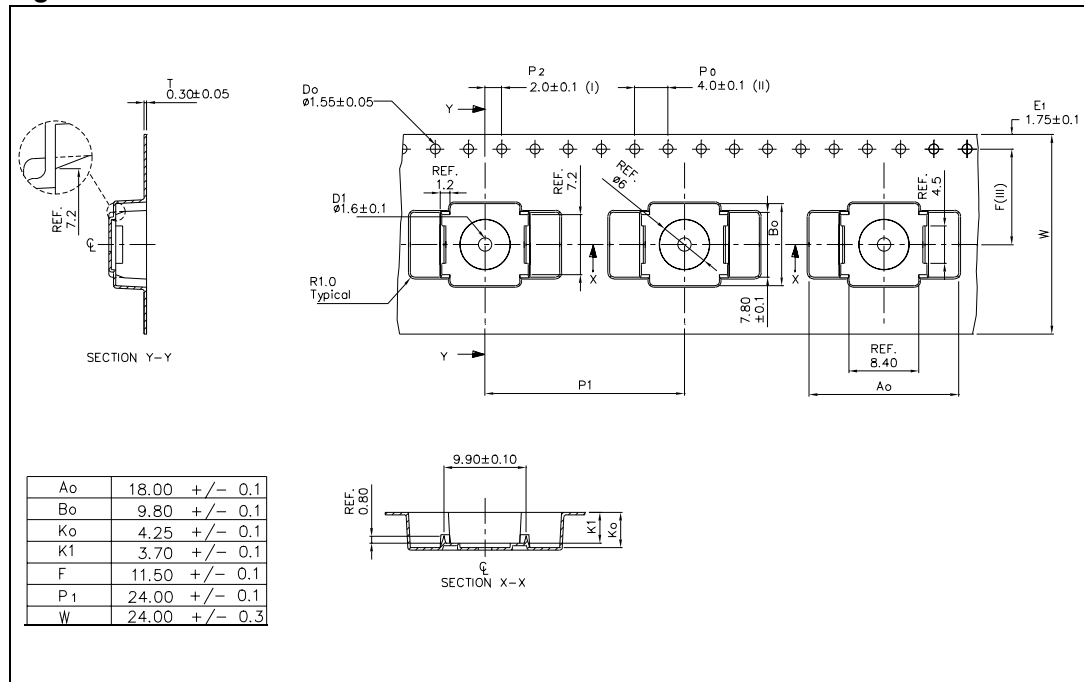

Figure 9. Reel information



## 6 Revision history

**Table 10. Document revision history**

Date	Revision	Changes
10-Mar-2008	1	Initial release
06-Jul-2009	2	Document status promoted from preliminary data to datasheet

**Please Read Carefully:**

Information in this document is provided solely in connection with ST products. STMicroelectronics NV and its subsidiaries ("ST") reserve the right to make changes, corrections, modifications or improvements, to this document, and the products and services described herein at any time, without notice.

All ST products are sold pursuant to ST's terms and conditions of sale.

Purchasers are solely responsible for the choice, selection and use of the ST products and services described herein, and ST assumes no liability whatsoever relating to the choice, selection or use of the ST products and services described herein.

No license, express or implied, by estoppel or otherwise, to any intellectual property rights is granted under this document. If any part of this document refers to any third party products or services it shall not be deemed a license grant by ST for the use of such third party products or services, or any intellectual property contained therein or considered as a warranty covering the use in any manner whatsoever of such third party products or services or any intellectual property contained therein.

**UNLESS OTHERWISE SET FORTH IN ST'S TERMS AND CONDITIONS OF SALE ST DISCLAIMS ANY EXPRESS OR IMPLIED WARRANTY WITH RESPECT TO THE USE AND/OR SALE OF ST PRODUCTS INCLUDING WITHOUT LIMITATION IMPLIED WARRANTIES OF MERCHANTABILITY, FITNESS FOR A PARTICULAR PURPOSE (AND THEIR EQUIVALENTS UNDER THE LAWS OF ANY JURISDICTION), OR INFRINGEMENT OF ANY PATENT, COPYRIGHT OR OTHER INTELLECTUAL PROPERTY RIGHT.**

**UNLESS EXPRESSLY APPROVED IN WRITING BY AN AUTHORIZED ST REPRESENTATIVE, ST PRODUCTS ARE NOT RECOMMENDED, AUTHORIZED OR WARRANTED FOR USE IN MILITARY, AIR CRAFT, SPACE, LIFE SAVING, OR LIFE SUSTAINING APPLICATIONS, NOR IN PRODUCTS OR SYSTEMS WHERE FAILURE OR MALFUNCTION MAY RESULT IN PERSONAL INJURY, DEATH, OR SEVERE PROPERTY OR ENVIRONMENTAL DAMAGE. ST PRODUCTS WHICH ARE NOT SPECIFIED AS "AUTOMOTIVE GRADE" MAY ONLY BE USED IN AUTOMOTIVE APPLICATIONS AT USER'S OWN RISK.**

Resale of ST products with provisions different from the statements and/or technical features set forth in this document shall immediately void any warranty granted by ST for the ST product or service described herein and shall not create or extend in any manner whatsoever, any liability of ST.

ST and the ST logo are trademarks or registered trademarks of ST in various countries.

Information in this document supersedes and replaces all information previously supplied.

The ST logo is a registered trademark of STMicroelectronics. All other names are the property of their respective owners.

© 2009 STMicroelectronics - All rights reserved

STMicroelectronics group of companies

Australia - Belgium - Brazil - Canada - China - Czech Republic - Finland - France - Germany - Hong Kong - India - Israel - Italy - Japan - Malaysia - Malta - Morocco - Philippines - Singapore - Spain - Sweden - Switzerland - United Kingdom - United States of America

[www.st.com](http://www.st.com)

