

PCS3P7303A

General Purpose Peak EMI Reduction IC

Functional Description

PCS3P7303A is a versatile, 3.3 V / 2.5 V Peak EMI reduction IC based on TIMING SAFE™ technology. PCS3P7303A accepts an input clock either from a Crystal or from an external reference (AC or DC coupled to XIN / CLKIN) and locks on to it delivering a 1x modulated clock output. PCS3P7303A has a Frequency Selection (FS) control that facilitates selecting one of the two frequency ranges within the operating frequency range. Refer to the *Frequency Selection* Table for details.

PCS3P7303A has an SSEXTR pin to select different deviations depending upon the value of an external resistor connected between SSEXTR and GND. Modulation Rate (MR) control selects two different Modulation Rates.

PCS3P7303A operates from a 3.3 V / 2.5 V supply and is available in an 8-pin TSSOP and 8L 2 mm x 2 mm WDFN packages.

Application

PCS3P7303A is targeted for many applications including USB and SATA.

General Features

- 1x LVCMOS Peak EMI Reduction
- Input Frequency:
 - ◆ 10 MHz – 70 MHz @ 2.5 V
 - ◆ 10 MHz – 80 MHz @ 3.3 V
- Output Frequency:
 - ◆ 10 MHz – 70 MHz @ 2.5 V
 - ◆ 10 MHz – 80 MHz @ 3.3 V
- Analog Deviation Selection
- ModRate Selection Option
- Supply Voltage: 2.5 V ± 0.2 V
3.3 V ± 0.3 V
- 8-pin TSSOP, 8L 2 mm x 2 mm WDFN (TDFN) Packages
- The First True Drop-in Solution
- These Devices are Pb-Free, Halogen Free/BFR Free and are RoHS Compliant



ON Semiconductor®

www.onsemi.com

MARKING DIAGRAMS

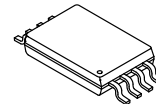

TSSOP8 4.4x3
CASE 948AL

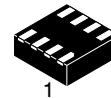
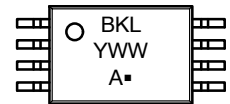

WDFN8 2x2, 0.5P
CASE 511AQ

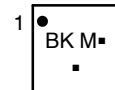

XX = Specific Device Code
M = Date Code
YY, Y = Year
WW, W = Work Week
A = Assembly Location
▪ = Pb-Free Device

(Note: Microdot may be in either location)

PIN CONFIGURATION

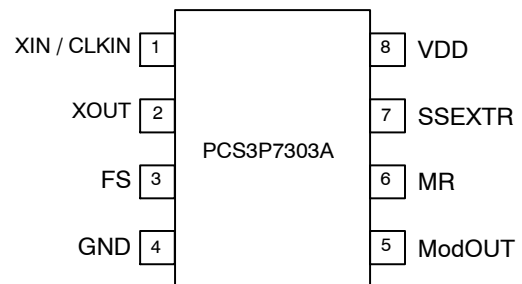

ORDERING INFORMATION

See detailed ordering and shipping information on page 7 of this data sheet.

PCS3P7303A

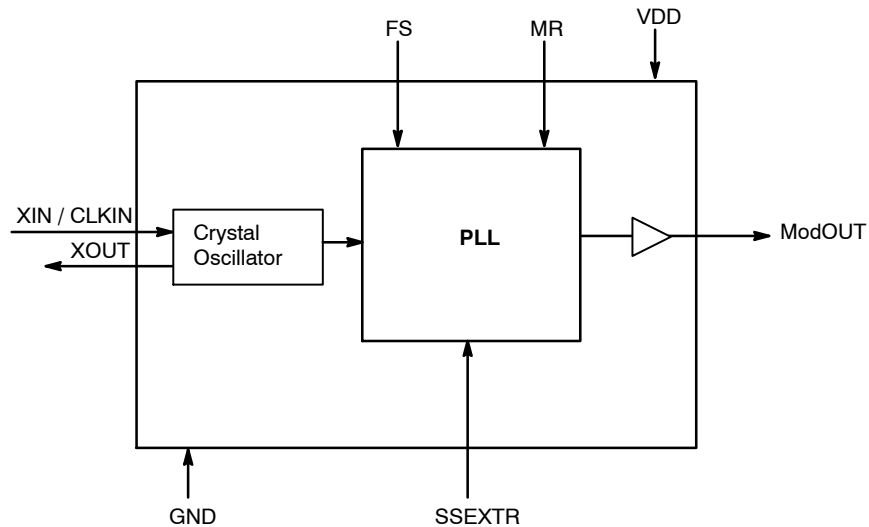

Figure 1. Block Diagram

Table 1. PIN DESCRIPTION

Pin #	Pin Name	Type	Description
1	XIN / CLKIN	Input	Crystal connection or External reference clock input.
2	XOUT	Output	Crystal connection. If using an external reference, this pin should be left open.
3	FS	Input	Frequency Select. Pull LOW to select Low Frequency range. Selects High Frequency range when pulled HIGH. Has an internal pull-up resistor. (See <i>Frequency Selection table</i> for details.)
4	GND	Power	Ground.
5	ModOUT	Output	Buffered Modulated clock output.
6	MR	input	Modulation Rate Select. When LOW selects Low Modulation Rate. Selects High Modulation Rate when pulled HIGH. Has an internal pull-down resistor.
7	SSEXTR	Input	Analog Deviation Selection through external resistor to GND.
8	VDD	Power	2.5 V / 3.3 V supply Voltage.

Table 2. FREQUENCY SELECTION TABLE

VDD (V)	FS	Frequency (MHz)
2.5	0	10 – 35
	1	30 – 70
3.3	0	10 – 40
	1	30 – 80

Table 3. ABSOLUTE MAXIMUM RATINGS

Symbol	Parameter	Rating	Unit
VDD, V _{IN}	Voltage on any input pin with respect to Ground	-0.5 to +4.6	V
T _{STG}	Storage temperature	-65 to +125	°C
T _s	Max. Soldering Temperature (10 sec)	260	°C
T _J	Junction Temperature	150	°C
T _{DV}	Static Discharge Voltage (As per JEDEC STD22- A114-B)	2	kV

Stresses exceeding those listed in the Maximum Ratings table may damage the device. If any of these limits are exceeded, device functionality should not be assumed, damage may occur and reliability may be affected.

PCS3P7303A

Table 4. OPERATING CONDITIONS

Parameter	Description	Min	Max	Unit
VDD	Supply Voltage	2.3	3.6	V
T _A	Operating Temperature (Ambient Temperature)	-25	+85	°C
C _L	Load Capacitance		10	pF
C _{IN}	Input Capacitance		7	pF

Functional operation above the stresses listed in the Recommended Operating Ranges is not implied. Extended exposure to stresses beyond the Recommended Operating Ranges limits may affect device reliability.

Table 5. DC ELECTRICAL CHARACTERISTICS FOR 2.5 V

Parameter	Description	Test Conditions	Min	Typ	Max	Units
VDD	Supply Voltage		2.3	2.5	2.7	V
V _{IL}	Input LOW Voltage				0.7	V
V _{IH}	Input HIGH Voltage		1.7			V
I _{IL}	Input LOW Current	V _{IN} = 0 V			-50	μA
I _{IH}	Input HIGH Current	V _{IN} = V _{DD}			50	μA
V _{OL}	Output LOW Voltage	I _{OL} = 8 mA			0.6	V
V _{OH}	Output HIGH Voltage	I _{OH} = -8 mA	1.8			V
I _{CC}	Static Supply Current	XIN / CLKIN pulled low			500	μA
I _{DD}	Dynamic Supply Current	Unloaded Output	FS = 0; @ 10 MHz		5	mA
			FS = 1; @ 70 MHz		12	
Z _O	Output Impedance			45		Ω

Product parametric performance is indicated in the Electrical Characteristics for the listed test conditions, unless otherwise noted. Product performance may not be indicated by the Electrical Characteristics if operated under different conditions.

Table 6. SWITCHING CHARACTERISTICS FOR 2.5 V

Parameter	Test Conditions		Min	Typ	Max	Units
Input Frequency (Note 1) / ModOUT	FS = 0		10		35	MHz
	FS = 1		30		70	
Duty Cycle (Notes 2, 3)	Measured at V _{DD} /2		45	50	55	%
Output Rise Time (Notes 2, 3)	Measured between 20% to 80%			1.75	2.5	nS
Output Fall Time (Notes 2, 3)	Measured between 80% to 20%			1.0	1.6	nS
Cycle-to-Cycle Jitter (Note 3)	Unloaded output	FS = 0	10 MHz	±450	±600	pS
			35 MHz	±125	±250	
		FS = 1	30 MHz	±225	±350	
			70 MHz	±150	±300	
PLL Lock Time (Note 3)	Stable power supply, valid clock presented on XIN / CLKIN				3	mS

1. Functionality with Crystal is guaranteed by design and characterization. Not 100% tested in production.
2. All parameters are specified with 10 pF loaded outputs.
3. Parameter is guaranteed by design and characterization. Not 100% tested in production.

PCS3P7303A

Table 7. DC ELECTRICAL CHARACTERISTICS FOR 3.3 V

Parameter	Description	Test Conditions		Min	Typ	Max	Units
VDD	Supply Voltage			3.0	3.3	3.6	V
V _{IL}	Input LOW Voltage					0.8	V
V _{IH}	Input HIGH Voltage			2.0			V
I _{IL}	Input LOW Current	V _{IN} = 0 V				-50	μA
I _{IH}	Input HIGH Current	V _{IN} = V _{DD}				50	μA
V _{OL}	Output LOW Voltage	I _{OL} = 8 mA				0.4	V
V _{OH}	Output HIGH Voltage	I _{OH} = -8 mA		2.4			V
I _{CC}	Static Supply Current	XIN / CLKIN pulled low				700	μA
I _{DD}	Dynamic Supply Current	Unloaded Output	FS = 0; @ 10 MHz			7	mA
			FS = 1; @ 80 MHz			20	
Z _O	Output Impedance				35		Ω

Product parametric performance is indicated in the Electrical Characteristics for the listed test conditions, unless otherwise noted. Product performance may not be indicated by the Electrical Characteristics if operated under different conditions.

Table 8. SWITCHING CHARACTERISTICS FOR 3.3 V

Parameter	Test Conditions		Min	Typ	Max	Units	
Input Frequency (Note 1) / ModOUT	FS = 0		10		40	MHz	
	FS = 1		30		80		
Duty Cycle (Notes 2, 3)	Measured at V _{DD} /2		45	50	55	%	
Output Rise Time (Notes 2, 3)	Measured between 20% to 80%			1.3	2	nS	
Output Fall Time (Notes 2, 3)	Measured between 80% to 20%			0.9	1.3	nS	
Cycle-to-Cycle Jitter (Note 3)	Unloaded output	FS = 0	10 MHz		±450	±600	pS
			40 MHz		±125	±250	
		FS = 1	30 MHz		±225	±350	
			80 MHz		±125	±250	
PLL Lock Time (Note 3)	Stable power supply, valid clock presented on XIN / CLKIN				3	mS	

4. Functionality with Crystal is guaranteed by design and characterization. Not 100% tested in production.
5. All parameters are specified with 10 pF loaded outputs.
6. Parameter is guaranteed by design and characterization. Not 100% tested in production.

Table 9. TYPICAL CRYSTAL SPECIFICATIONS

Fundamental AT Cut Parallel Resonant Crystal	
Nominal frequency	25 MHz
Frequency tolerance	±50 ppm or better at 25°C
Operating temperature range	-25°C to +85°C
Storage temperature	-40°C to +85°C
Load capacitance (C _P)	18 pF
Shunt capacitance	7 pF maximum
ESR	25 Ω

NOTE: C_L is the Load Capacitance and R1 is used to prevent oscillations at overtone frequency of the Fundamental frequency.

PCS3P7303A

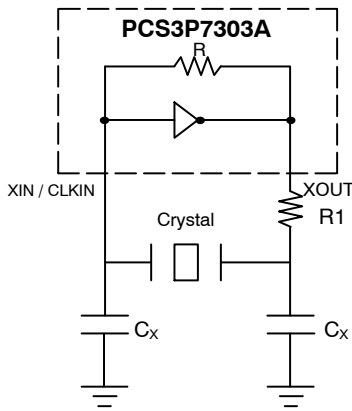

$C_X = 2 * (C_P - C_S)$,
 Where C_P = Load capacitance of crystal from crystal vendor datasheet.
 C_S = Stray capacitance due to C_{IN} , PCB, Trace, etc.

Figure 2. Typical Crystal Interface Circuit

Switching Waveforms

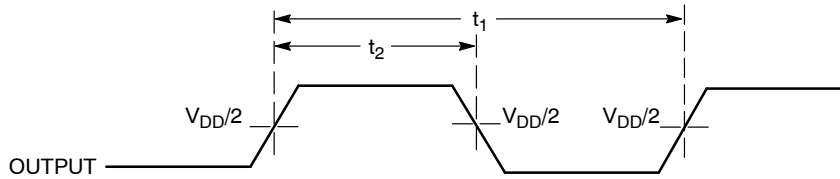

Figure 3. Duty Cycle Timing

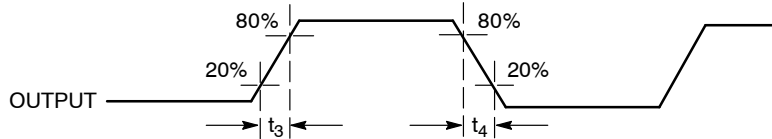
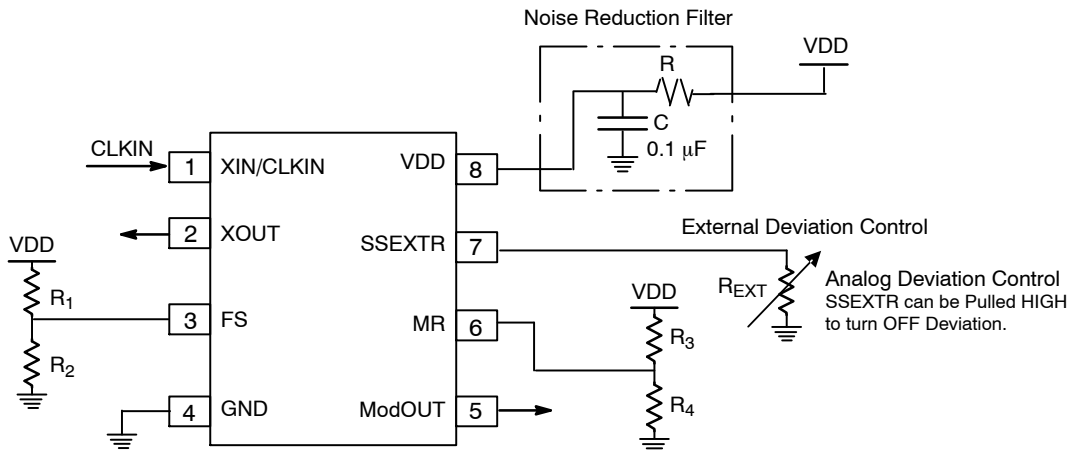

Figure 4. Output Rise/Fall Time

Application Schematic



Note: FS (Pin#3) MR (Pin#6): Connect to VDD or GND

Refer to Pin Description table for Functionality details.

Use 0 Ω resistor at either R_1 or R_2 to configure FS.

Use 0 Ω resistor at either R_3 or R_4 to configure MR.

Figure 5. Application Schematic

PCS3P7303A

Charts

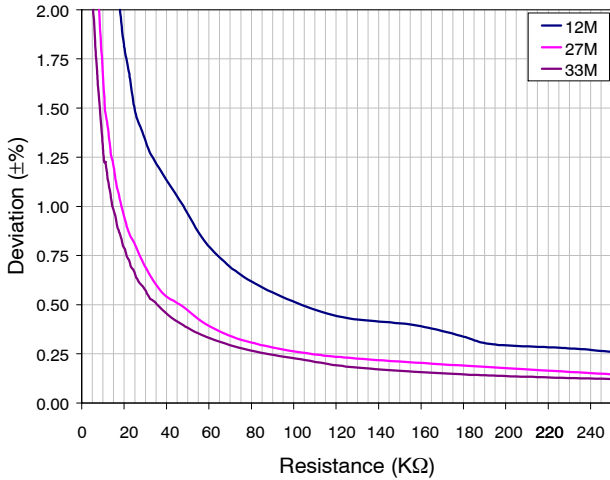

Figure 6. Deviation vs. Resistance (FS = 0, MR = 0)

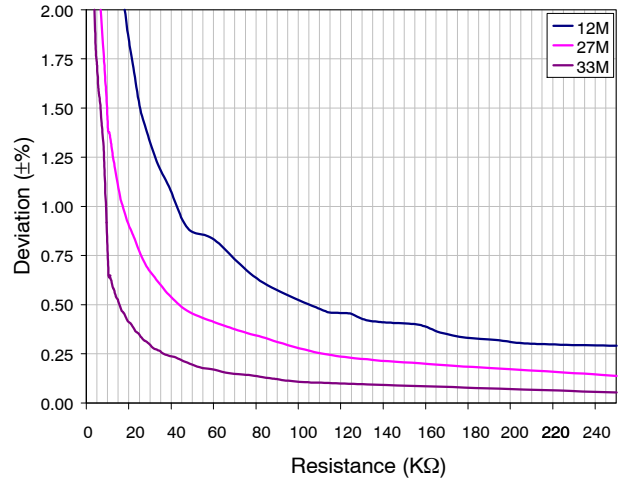

Figure 7. Deviation vs. Resistance (FS = 0, MR = 1)

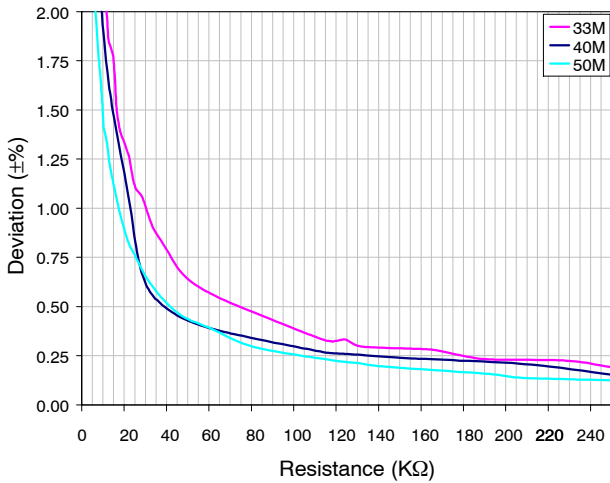

Figure 8. Deviation vs. Resistance (FS = 1, MR = 0)

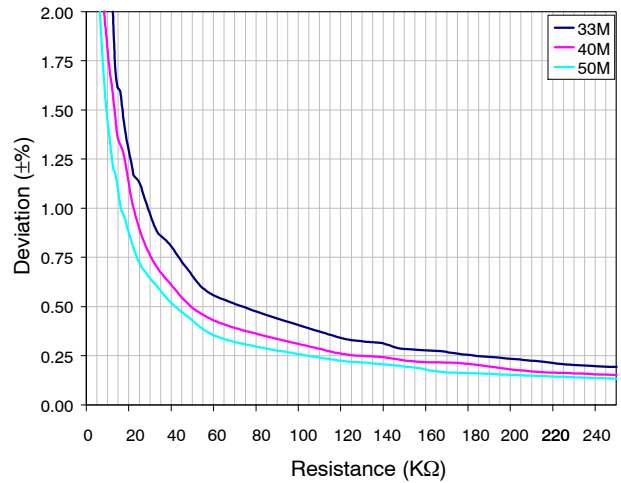

Figure 9. Deviation vs. Resistance (FS = 1, MR = 1)

NOTE: Device to Device variation of Deviation is $\pm 10\%$ (0°C to 70°C) and $\pm 25\%$ (-25°C to $+85^{\circ}\text{C}$)

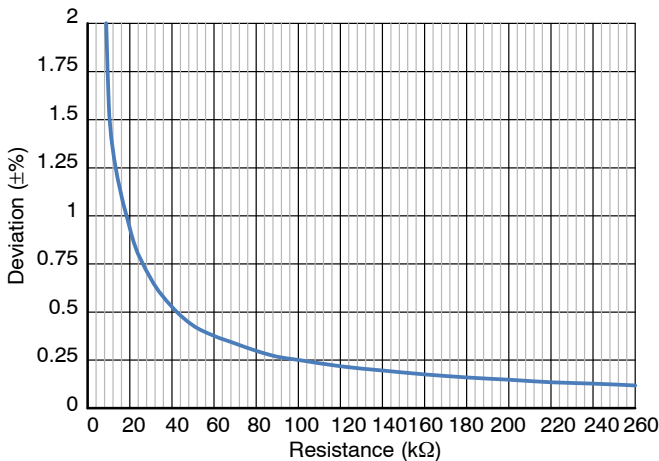

Figure 10. Deviation vs. Resistance (FS = 1, MR = 0) $V_{DD} = 3.3\text{ V}$

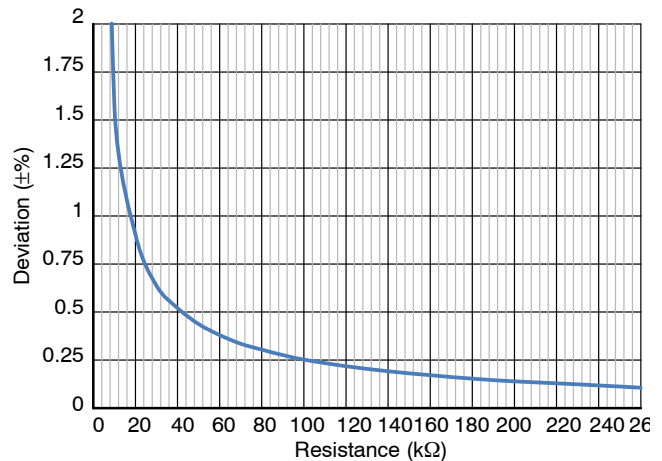

Figure 11. Deviation vs. Resistance (FS = 1, MR = 1) $V_{DD} = 3.3\text{ V}$

PCS3P7303A

Table 10. ORDERING INFORMATION

Part Number	Marking	Temperature	Package	Shipping†
PCS3P7303AG-08TR	BKL	-25°C to +85°C	8-pin TSSOP (Pb-Free)	Tape & Reel
PCS3P7303AG-08TT	BKL	-25°C to +85°C	8-pin TSSOP (Pb-Free)	Tube
PCS3P7303AG-08CR	BK	-25°C to +85°C	8L WDFN (2 mm x 2 mm) (Pb-Free)	Tape & Reel

†For information on tape and reel specifications, including part orientation and tape sizes, please refer to our Tape and Reel Packaging Specifications Brochure, BRD8011/D.

NOTE: A “microdot” placed at the end of last row of marking or just below the last row toward the center of package indicates Pb-Free.

PCS3P7303A

PACKAGE DIMENSIONS

TSSOP8, 4.4x3
CASE 948AL
ISSUE O

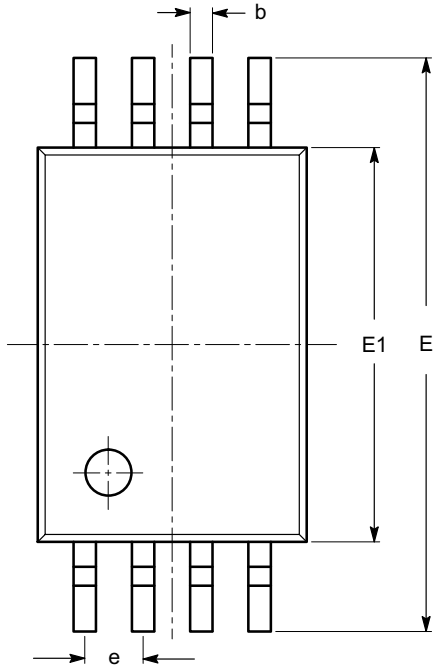

SYMBOL	MIN	NOM	MAX
A			1.20
A1	0.05		0.15
A2	0.80	0.90	1.05
b	0.19		0.30
c	0.09		0.20
D	2.90	3.00	3.10
E	6.30	6.40	6.50
E1	4.30	4.40	4.50
e	0.65 BSC		
L	1.00 REF		
L1	0.50	0.60	0.75
θ	0°		8°

TOP VIEW

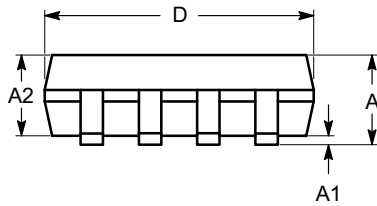

SIDE VIEW

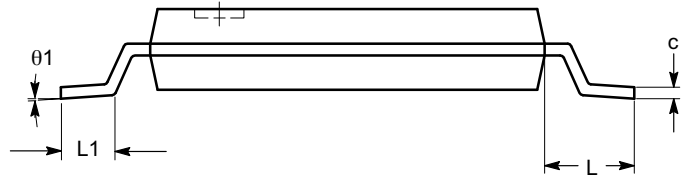

END VIEW

Notes:

- (1) All dimensions are in millimeters. Angles in degrees.
- (2) Complies with JEDEC MO-153.

PCS3P7303A

PACKAGE DIMENSIONS

WDFN8 2x2, 0.5P CASE 511AQ ISSUE A

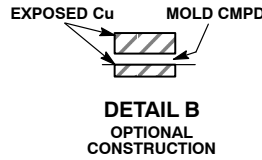
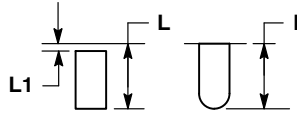
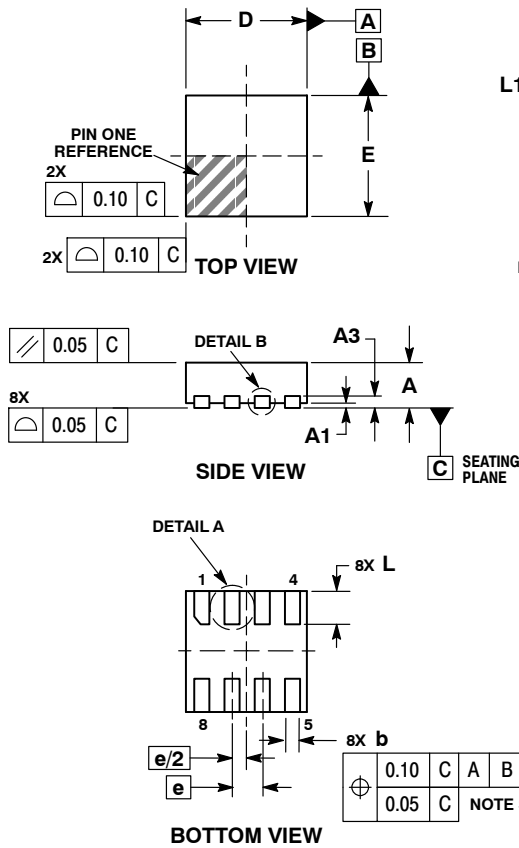

- NOTES:
1. DIMENSIONING AND TOLERANCING PER ASME Y14.5M, 1994.
 2. CONTROLLING DIMENSION: MILLIMETERS.
 3. DIMENSION b APPLIES TO PLATED TERMINAL AND IS MEASURED BETWEEN 0.15 AND 0.30mm FROM TERMINAL.

DIM	MILLIMETERS	
	MIN	MAX
A	0.70	0.80
A1	0.00	0.05
A3	0.20 REF	
b	0.20	0.30
D	2.00 BSC	
E	2.00 BSC	
e	0.50 BSC	
L	0.50	0.60
L1	---	0.15

RECOMMENDED SOLDERING FOOTPRINT*

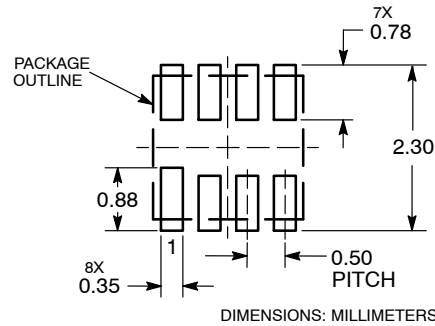

*For additional information on our Pb-Free strategy and soldering details, please download the ON Semiconductor Soldering and Mounting Techniques Reference Manual, SOLDERRM/D.

TIMING SAFE is a trademark of Semiconductor Components Industries, LLC (SCILLC).

ON Semiconductor and the are registered trademarks of Semiconductor Components Industries, LLC (SCILLC) or its subsidiaries in the United States and/or other countries. SCILLC owns the rights to a number of patents, trademarks, copyrights, trade secrets, and other intellectual property. A listing of SCILLC's product/patent coverage may be accessed at www.onsemi.com/site/pdf/Patent-Marking.pdf. SCILLC reserves the right to make changes without further notice to any products herein. SCILLC makes no warranty, representation or guarantee regarding the suitability of its products for any particular purpose, nor does SCILLC assume any liability arising out of the application or use of any product or circuit, and specifically disclaims any and all liability, including without limitation special, consequential or incidental damages. "Typical" parameters which may be provided in SCILLC data sheets and/or specifications can and do vary in different applications and actual performance may vary over time. All operating parameters, including "Typicals" must be validated for each customer application by customer's technical experts. SCILLC does not convey any license under its patent rights nor the rights of others. SCILLC products are not designed, intended, or authorized for use as components in systems intended for surgical implant into the body, or other applications intended to support or sustain life, or for any other application in which the failure of the SCILLC product could create a situation where personal injury or death may occur. Should Buyer purchase or use SCILLC products for any such unintended or unauthorized application, Buyer shall indemnify and hold SCILLC and its officers, employees, subsidiaries, affiliates, and distributors harmless against all claims, costs, damages, and expenses, and reasonable attorney fees arising out of, directly or indirectly, any claim of personal injury or death associated with such unintended or unauthorized use, even if such claim alleges that SCILLC was negligent regarding the design or manufacture of the part. SCILLC is an Equal Opportunity/Affirmative Action Employer. This literature is subject to all applicable copyright laws and is not for resale in any manner.

PUBLICATION ORDERING INFORMATION

LITERATURE FULFILLMENT:
Literature Distribution Center for ON Semiconductor
P.O. Box 5163, Denver, Colorado 80217 USA
Phone: 303-675-2175 or 800-344-3860 Toll Free USA/Canada
Fax: 303-675-2176 or 800-344-3867 Toll Free USA/Canada
Email: orderlit@onsemi.com

N. American Technical Support: 800-282-9855 Toll Free
USA/Canada
Europe, Middle East and Africa Technical Support:
Phone: 421 33 790 2910
Japan Customer Focus Center
Phone: 81-3-5817-1050

ON Semiconductor Website: www.onsemi.com
Order Literature: <http://www.onsemi.com/orderlit>
For additional information, please contact your local Sales Representative