



PCF8562

Universal LCD driver for low multiplex rates

Rev. 04 — 18 March 2009

Product data sheet

1. General description

The PCF8562 is a peripheral device which interfaces to almost any Liquid Crystal Display (LCD) with low multiplex rates. It generates the drive signals for any static or multiplexed LCD containing up to four backplanes and up to 32 segments. The PCF8562 is compatible with most microprocessors or microcontrollers and communicates via a two-line bidirectional I²C-bus. Communication overheads are minimized by a display RAM with auto-incremented addressing, by hardware subaddressing and by display memory switching (static and duplex drive modes).

AEC-Q100 compliant (PCF8562TT/S400) for automotive applications.

2. Features

- Single chip LCD controller and driver
- Selectable backplane drive configuration: static or 2, 3, 4 backplane multiplexing
- Selectable display bias configuration: static, $\frac{1}{2}$ or $\frac{1}{3}$
- Internal LCD bias generation with voltage-follower buffers
- 32 segment drives:
 - ◆ Up to sixteen 7-segment numeric characters
 - ◆ Up to eight 14-segment alphanumeric characters
 - ◆ Any graphics of up to 128 elements
- 32 × 4-bit RAM for display data storage
- Auto-incremented display data loading across device subaddress boundaries
- Display memory bank switching in static and duplex drive modes
- Versatile blinking modes
- Independent supplies possible for LCD and logic voltages
- Wide power supply range: from 1.8 V to 5.5 V
- Wide logic LCD supply range:
 - ◆ From 2.5 V for low-threshold LCDs
 - ◆ Up to 6.5 V for guest-host LCDs and high-threshold twisted nematic LCDs
- Low power consumption
- 400 kHz I²C-bus interface
- No external components
- Manufactured in silicon gate CMOS process

3. Ordering information

Table 1. Ordering information

Type number	Package		
	Name	Description	Version
PCF8562TT/2	TSSOP48	plastic thin shrink small outline package; 48 leads; body width 6.1 mm	SOT362-1
PCF8562TT/S400/2	TSSOP48	plastic thin shrink small outline package; 48 leads; body width 6.1 mm	SOT362-1

4. Marking

Table 2. Marking codes

Type number	Marking code
PCF8562TT/2	PCF8562TT
PCF8562TT/S400/2	PCF8562TT

5. Block diagram

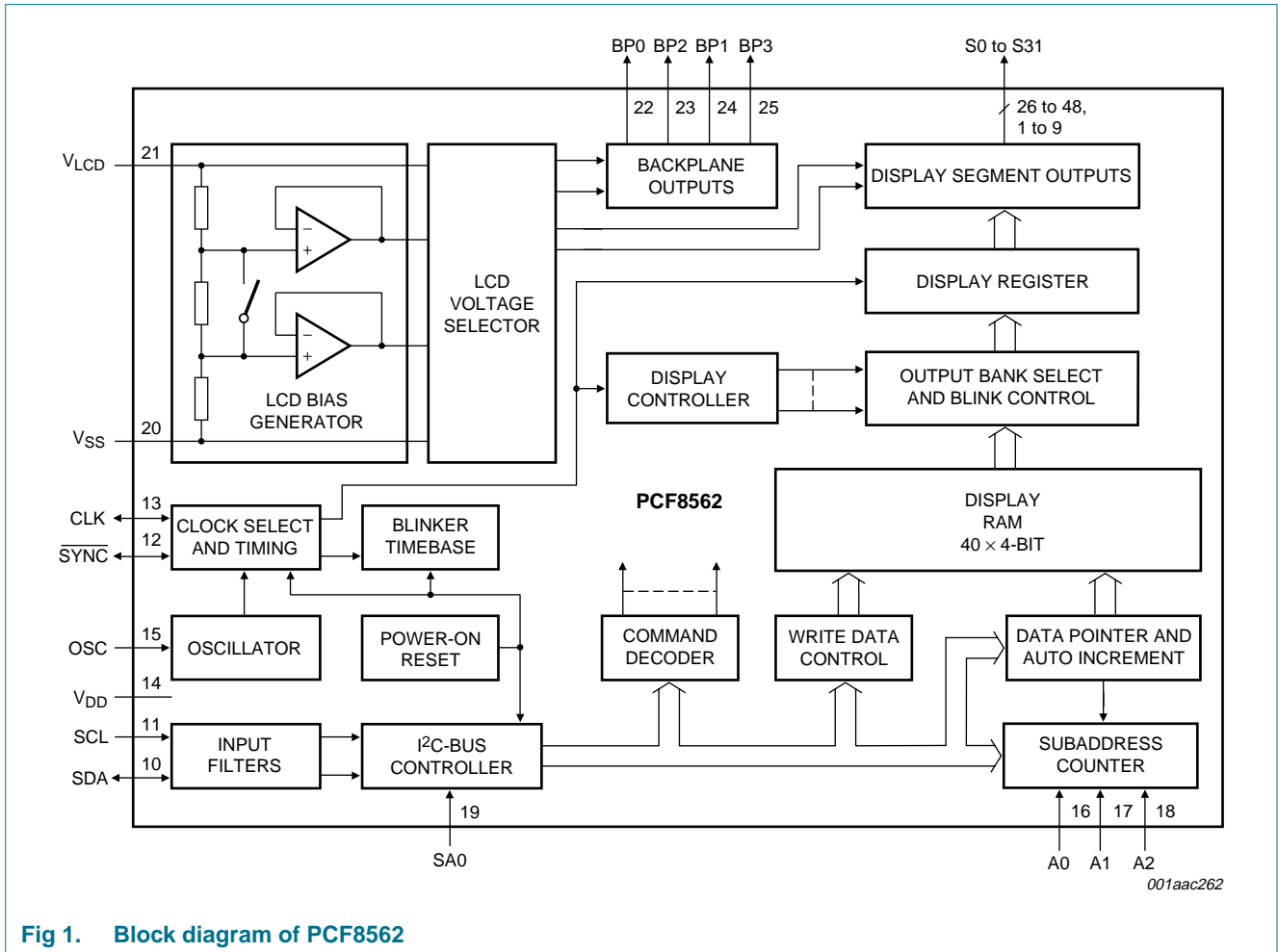
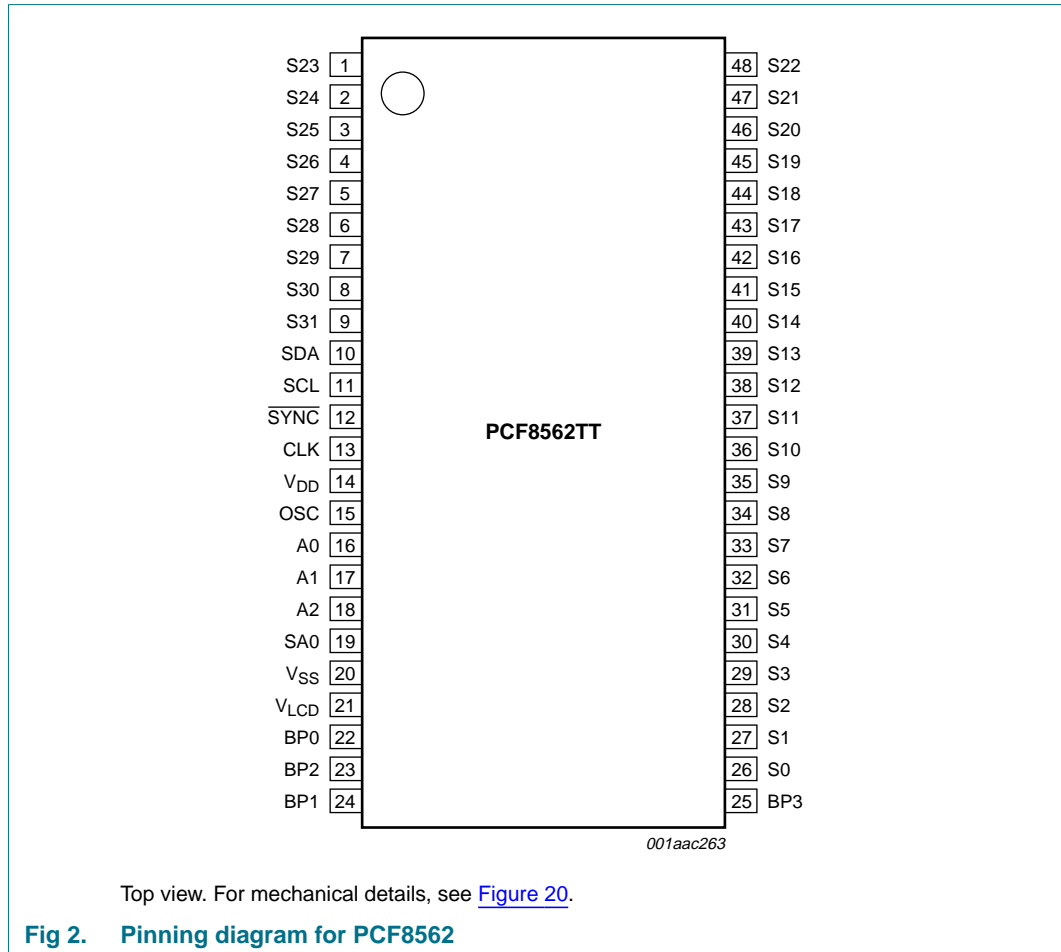

Fig 1. Block diagram of PCF8562

6. Pinning information

6.1 Pinning



6.2 Pin description

Table 3. Pin description

Symbol	Pin	Description
SDA	10	I ² C-bus serial data input and output
SCL	11	I ² C-bus serial clock input
SYNC	12	cascade synchronization input or output
CLK	13	external clock input or output
V _{DD}	14	supply voltage
OSC	15	internal oscillator enable input
A0 to A2	16 to 18	subaddress inputs
SA0	19	I ² C-bus address input; bit 0
V _{SS}	20	ground supply voltage
V _{LCD}	21	LCD supply voltage
BP0 to BP3	22 to 25	LCD backplane outputs
S0 to S22, S23 to S31	26 to 48, 1 to 9	LCD segment outputs

7. Functional description

The PCF8562 is a versatile peripheral device designed to interface any microprocessor or microcontroller with a wide variety of LCDs. It can directly drive any static or multiplexed LCD containing up to four backplanes and up to 32 segments.

The possible display configurations of the PCF8562 depend on the number of active backplane outputs required. A selection of display configurations is shown in [Table 4](#). All of these configurations can be implemented in the typical system shown in [Figure 3](#).

Table 4. Display configurations

Number of:		7-segment numeric		14-segment numeric		Dot matrix
Backplanes	Segments	Digits	Indicator symbols	Characters	Indicator symbols	
4	128	16	16	8	16	128 dots (4 × 32)
3	96	12	12	6	12	96 dots (3 × 32)
2	64	8	8	4	8	64 dots (2 × 32)
1	32	4	4	2	4	32 dots (1 × 32)

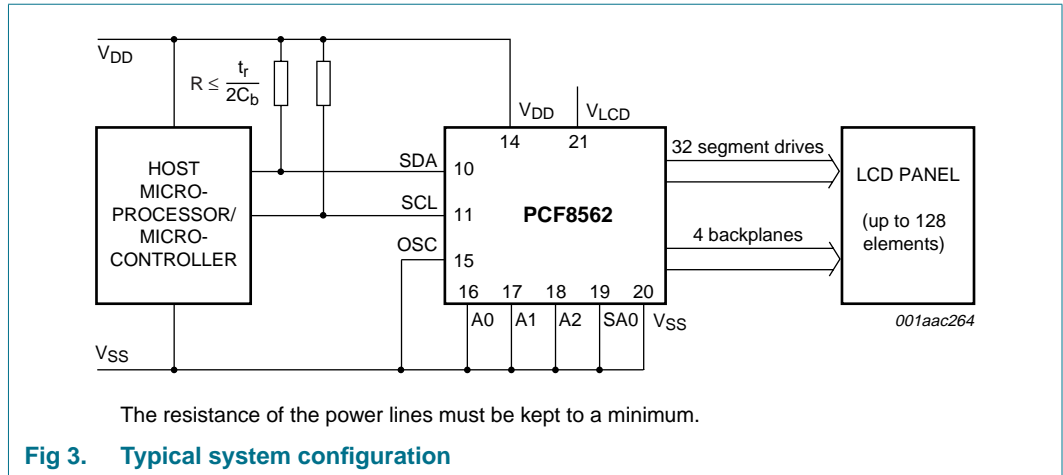

The host microprocessor or microcontroller maintains the 2-line I²C-bus communication channel with the PCF8562. The internal oscillator is enabled by connecting pin OSC to pin V_{SS}. The appropriate biasing voltages for the multiplexed LCD waveforms are generated internally. The only other connections required to complete the system are to the power supplies (V_{DD}, V_{SS} and V_{LCD}) and the LCD panel chosen for the application.

7.1 Power-on reset

At power-on the PCF8562 resets to the following starting conditions:

- All backplane outputs are set to V_{LCD}
- All segment outputs are set to V_{LCD}
- The selected drive mode is: 1:4 multiplex with 1/3 bias
- Blinking is switched off
- Input and output bank selectors are reset
- The I²C-bus interface is initialized
- The data pointer and the subaddress counter are cleared (set to logic 0)
- Display is disabled

Data transfers on the I²C-bus must be avoided for 1 ms following power-on to allow the reset action to complete.

7.2 LCD bias generator

Fractional LCD biasing voltages are obtained from an internal voltage divider consisting of three impedances connected in series between V_{LCD} and V_{SS}. The middle resistor can be bypassed to provide a 1/2 bias voltage level for the 1:2 multiplex configuration. The LCD voltage can be temperature compensated externally using the supply to pin V_{LCD}.

7.3 LCD voltage selector

The LCD voltage selector coordinates the multiplexing of the LCD in accordance with the selected LCD drive configuration. The operation of the voltage selector is controlled by the mode-set command (see [Section 7.17](#)) from the command decoder. The biasing

configurations that apply to the preferred modes of operation, together with the biasing characteristics as functions of V_{LCD} and the resulting discrimination ratios (D), are given in [Table 5](#).

Table 5. Discrimination ratios

LCD drive mode	Number of:		LCD bias configuration	$\frac{V_{off(RMS)}}{V_{LCD}}$	$\frac{V_{on(RMS)}}{V_{LCD}}$	$D = \frac{V_{on(RMS)}}{V_{off(RMS)}}$
	Backplanes	Levels				
static	1	2	static	0	1	∞
1:2 multiplex	2	3	$\frac{1}{2}$	0.354	0.791	2.236
1:2 multiplex	2	4	$\frac{1}{3}$	0.333	0.745	2.236
1:3 multiplex	3	4	$\frac{1}{3}$	0.333	0.638	1.915
1:4 multiplex	4	4	$\frac{1}{3}$	0.333	0.577	1.732

A practical value for V_{LCD} is determined by equating $V_{off(RMS)}$ with a defined LCD threshold voltage (V_{th}), typically when the LCD exhibits approximately 10 % contrast. In the static drive mode a suitable choice is $V_{LCD} > 3V_{th}$.

Multiplex drive modes of 1:3 and 1:4 with $\frac{1}{2}$ bias are possible but the discrimination and hence the contrast ratios are smaller.

Bias is calculated by $\frac{1}{1+a}$, where the values for a are

a = 1 for $\frac{1}{2}$ bias

a = 2 for $\frac{1}{3}$ bias

The RMS on-state voltage ($V_{on(RMS)}$) for the LCD is calculated with the equation

$$V_{on(RMS)} = V_{LCD} \sqrt{\frac{\frac{1}{n} + \left[(n-1) \times \left(\frac{1}{1+a} \right) \right]^2}{n}} \tag{1}$$

where V_{LCD} is the resultant voltage at the LCD segment and where the values for n are

n = 1 for static mode

n = 2 for 1:2 multiplex

n = 3 for 1:3 multiplex

n = 4 for 1:4 multiplex

The RMS off-state voltage ($V_{off(RMS)}$) for the LCD is calculated with the equation:

$$V_{off(RMS)} = V_{LCD} \sqrt{\frac{a^2 - (2a+n)}{n \times (1+a)^2}} \tag{2}$$

Discrimination is the ratio of $V_{on(RMS)}$ to $V_{off(RMS)}$ and is determined from the equation:

$$\frac{V_{on(RMS)}}{V_{off(RMS)}} = \sqrt{\frac{(a+1)^2 + (n-1)}{(a-1)^2 + (n-1)}} \tag{3}$$

Using [Equation 3](#), the discrimination for an LCD drive mode of 1:3 multiplex with $\frac{1}{2}$ bias is $\sqrt{3} = 1.732$ and the discrimination for an LCD drive mode of 1:4 multiplex with $\frac{1}{2}$ bias is $\frac{\sqrt{21}}{3} = 1.528$.

The advantage of these LCD drive modes is a reduction of the LCD full scale voltage V_{LCD} as follows:

- 1:3 multiplex ($\frac{1}{2}$ bias): $V_{LCD} = \sqrt{6} \times V_{off(RMS)} = 2.449V_{off(RMS)}$;
- 1:4 multiplex ($\frac{1}{2}$ bias): $V_{LCD} = \left[\frac{(4 \times \sqrt{3})}{3} \right] = 2.309V_{off(RMS)}$

These compare with $V_{LCD} = 3V_{off(RMS)}$ when $\frac{1}{3}$ bias is used.

It should be noted that V_{LCD} is sometimes referred as the LCD operating voltage.

7.4 LCD drive mode waveforms

7.4.1 Static drive mode

The static LCD drive mode is used when a single backplane is provided in the LCD. The backplane (BPn) and segment drive (Sn) waveforms for this mode are shown in [Figure 4](#).

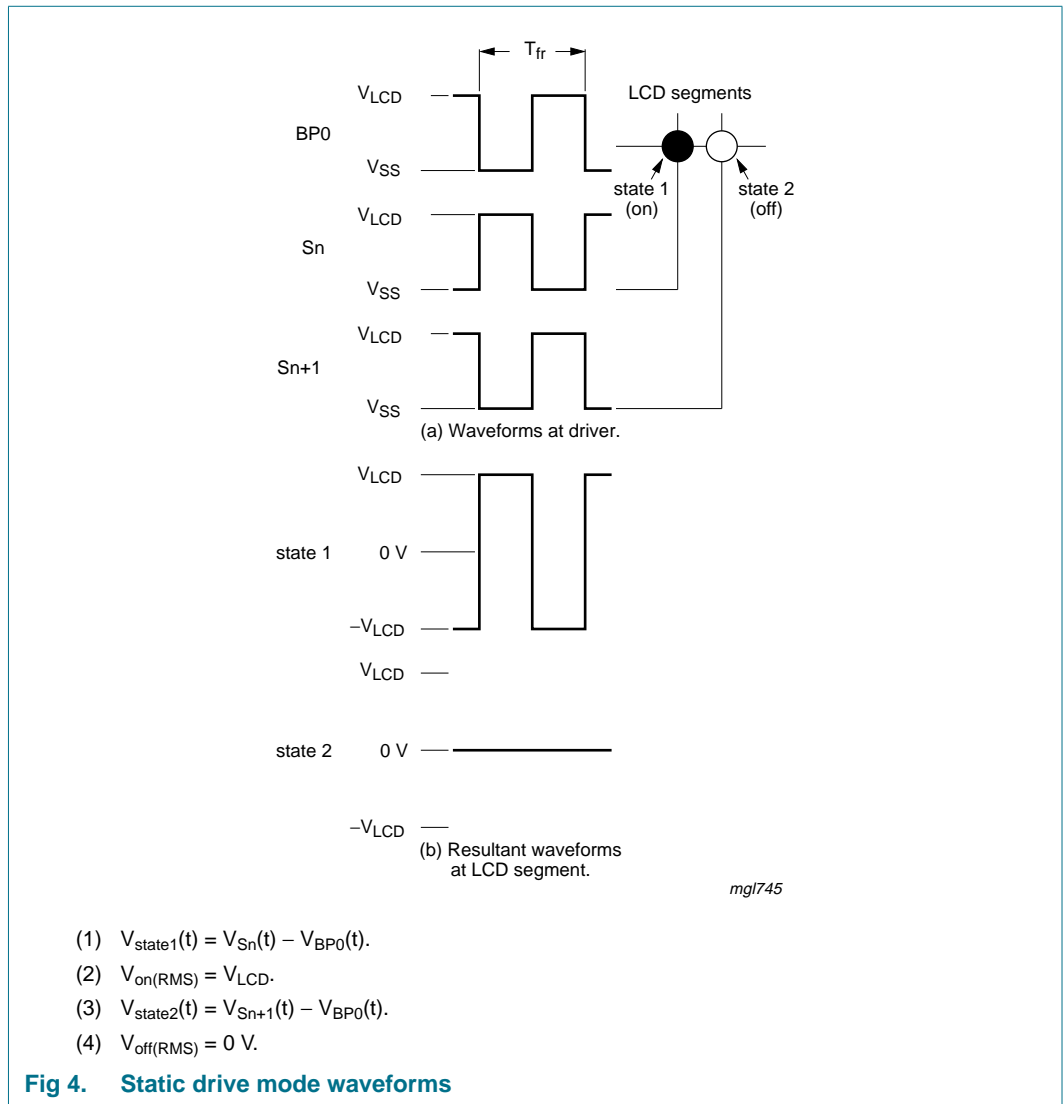

7.4.2 1:2 Multiplex drive mode

The 1:2 multiplex drive mode is used when two backplanes are provided in the LCD. This mode allows fractional LCD bias voltages of $\frac{1}{2}$ bias or $\frac{1}{3}$ bias as shown in [Figure 5](#) and [Figure 6](#).

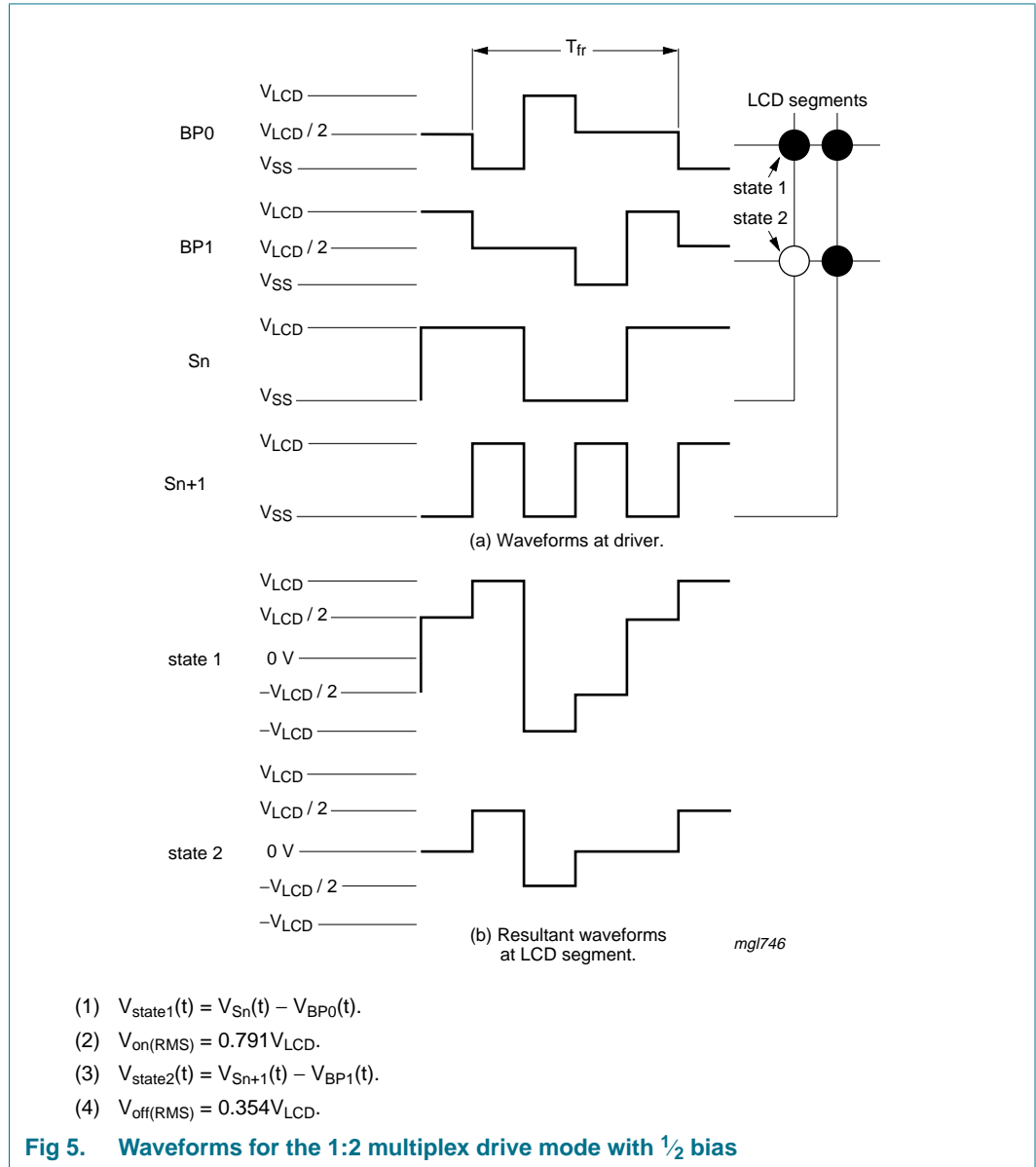

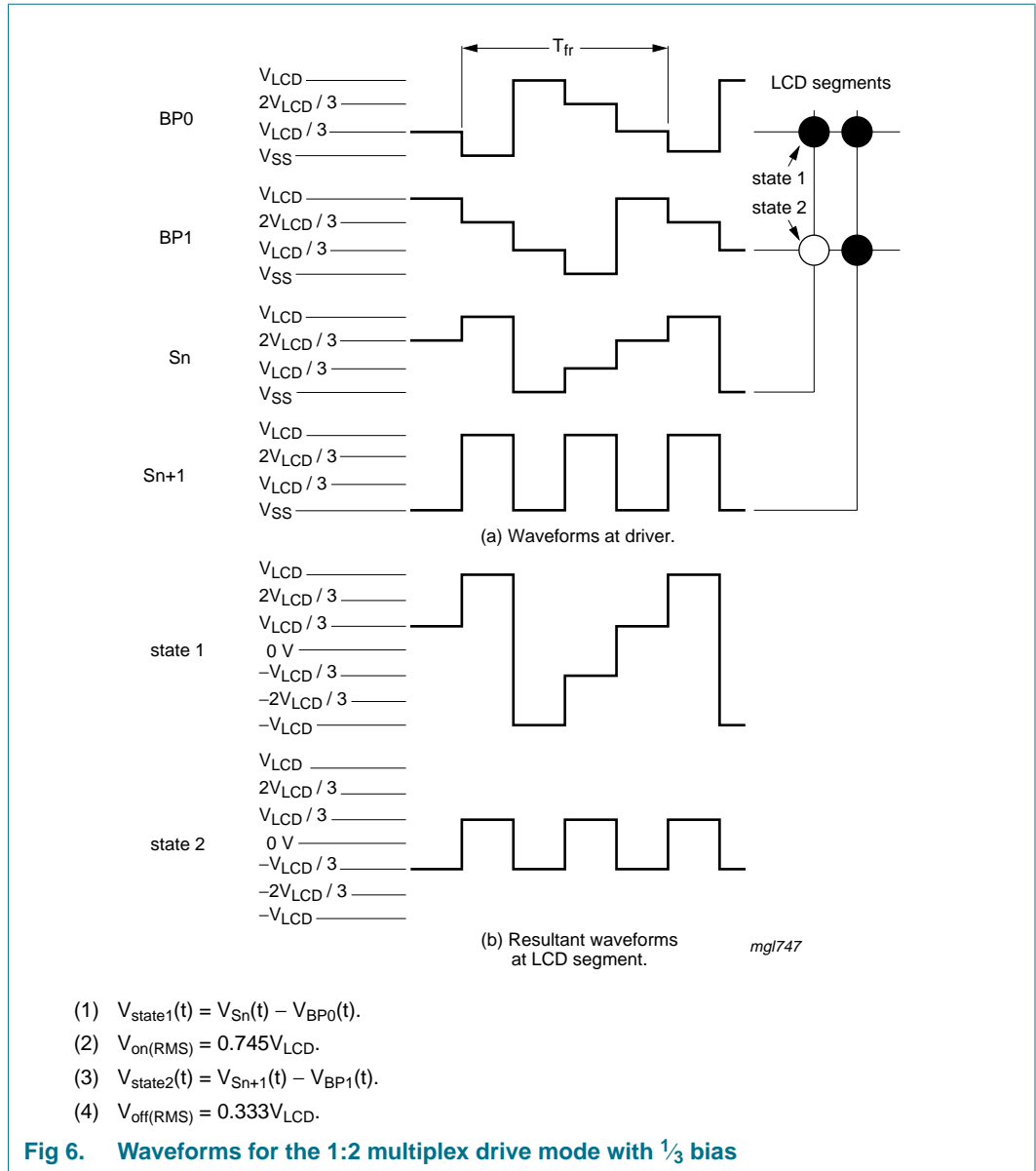

7.4.3 1:3 Multiplex drive mode

When three backplanes are provided in the LCD, the 1:3 multiplex drive mode applies (see Figure 7).

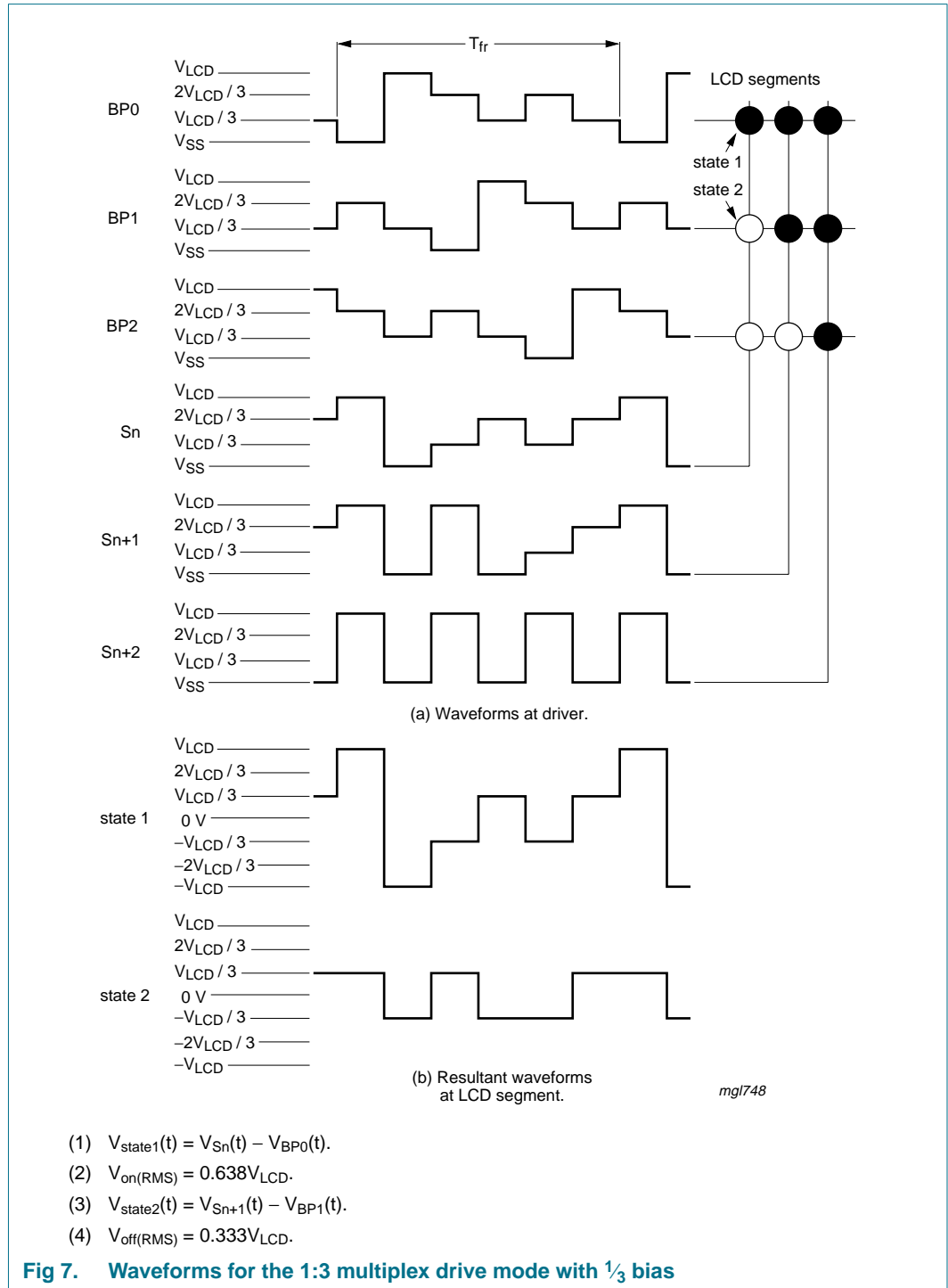
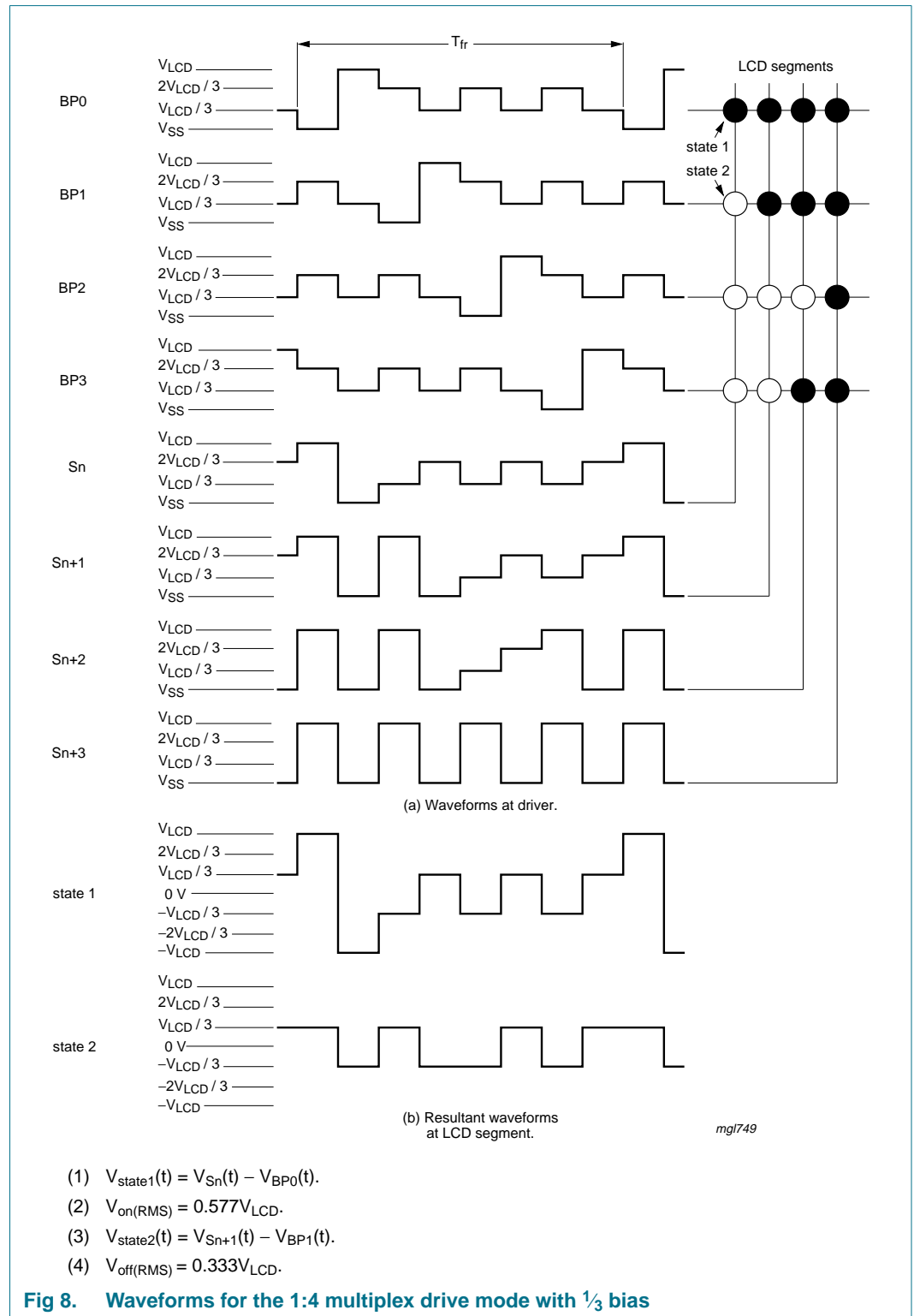

Fig 7. Waveforms for the 1:3 multiplex drive mode with 1/3 bias

7.4.4 1:4 Multiplex drive mode

When four backplanes are provided in the LCD, the 1:4 multiplex drive mode applies (see Figure 8).



7.5 Oscillator

7.5.1 Internal clock

The internal logic of the PCF8562 and its LCD drive signals are timed either by its internal oscillator or by an external clock. The internal oscillator is enabled by connecting pin OSC to pin V_{SS}. After power-on, pin SDA must be HIGH to guarantee that the clock starts.

7.5.2 External clock

Pin CLK is enabled as an external clock input by connecting pin OSC to V_{DD}.

The LCD frame signal frequency is determined by the clock frequency (f_{clk}).

A clock signal must always be supplied to the device; removing the clock freezes the LCD in a DC state.

7.6 Timing

The PCF8562 timing controls the internal data flow of the device. This includes the transfer of display data from the display RAM to the display segment outputs. The timing also generates the LCD frame signal whose frequency is derived from the clock frequency. The frame signal frequency is a fixed division of the clock frequency from either

the internal or an external clock: $f_{fr} = \frac{f_{clk}}{24}$.

7.7 Display register

The display latch holds the display data while the corresponding multiplex signals are generated. There is a one-to-one relationship between the data in the display latch, the LCD segment outputs and each column of the display RAM.

7.8 Segment outputs

The LCD drive section includes 32 segment outputs S0 to S31 which should be connected directly to the LCD. The segment output signals are generated in accordance with the multiplexed backplane signals and with data residing in the display latch. When less than 32 segment outputs are required, the unused segment outputs should be left open-circuit.

7.9 Backplane outputs

The LCD drive section includes four backplane outputs BP0 to BP3 which must be connected directly to the LCD. The backplane output signals are generated in accordance with the selected LCD drive mode. If less than four backplane outputs are required, the unused outputs can be left open-circuit.

In the 1:3 multiplex drive mode, BP3 carries the same signal as BP1, therefore these two adjacent outputs can be tied together to give enhanced drive capabilities.

In the 1:2 multiplex drive mode, BP0 and BP2, BP1 and BP3 all carry the same signals and may also be paired to increase the drive capabilities.

In the static drive mode the same signal is carried by all four backplane outputs and they can be connected in parallel for very high drive requirements.

7.10 Display RAM

The display RAM is a static 32 × 4-bit RAM which stores LCD data. A logic 1 in the RAM bit-map indicates the on-state of the corresponding LCD element; similarly, a logic 0 indicates the off-state. There is a one-to-one correspondence between the RAM addresses and the segment outputs, and between the individual bits of a RAM word and the backplane outputs. The display RAM bit map [Figure 9](#) shows the rows 0 to 3 which correspond with the backplane outputs BP0 to BP3, and the columns 0 to 31 which correspond with the segment outputs S0 to S31. In multiplexed LCD applications the segment data of the first, second, third and fourth row of the display RAM are time-multiplexed with BP0, BP1, BP2 and BP3 respectively.

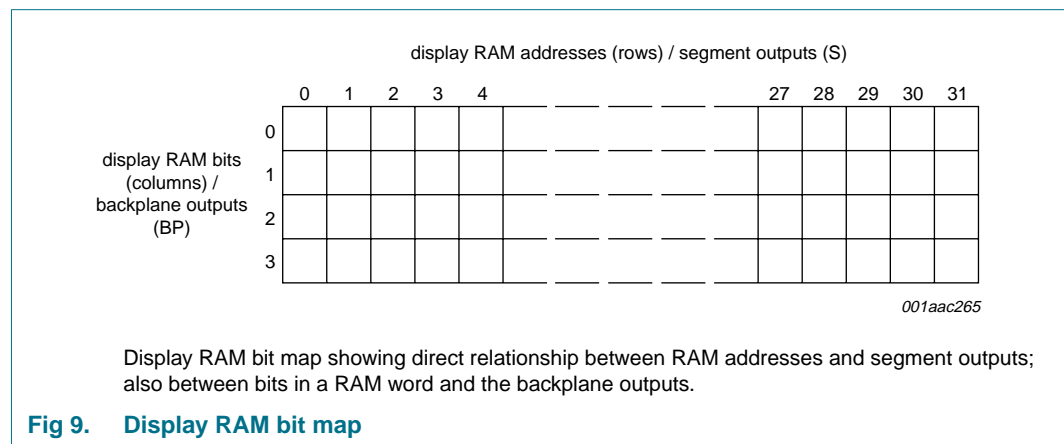

When display data is transmitted to the PCF8562, the display bytes received are stored in the display RAM in accordance with the selected LCD drive mode. The data is stored as it arrives and does not wait for an acknowledge cycle as with the commands. Depending on the current multiplex drive mode, data is stored singularly, in pairs, triplets or quadruplets. To illustrate the filling order, an example of a 7-segment numeric display showing all drive modes is given in [Figure 10](#); the RAM filling organization depicted applies equally to other LCD types.

The following applies to [Figure 10](#):

- In the static drive mode, the eight transmitted data bits are placed in row 0 of eight successive 4-bit RAM words.
- In the 1:2 multiplex mode, the eight transmitted data bits are placed in pairs into row 0 and 1 of four successive 4-bit RAM words.
- In the 1:3 multiplex mode, the eight bits are placed in triples into row 0, 1 and 2 to three successive 4-bit RAM words, with bit 3 of the third address left unchanged. It is not recommended to use this bit in a display because of the difficult addressing. This last bit may, if necessary, be controlled by an additional transfer to this address but care should be taken to avoid overwriting adjacent data because always full bytes are transmitted.
- In the 1:4 multiplex mode, the eight transmitted data bits are placed in quadruples into row 0, 1, 2 and 3 of two successive 4-bit RAM words.

drive mode	LCD segments	LCD backplanes	display RAM filling order	transmitted display byte																																																									
static			display RAM addresses (columns)/segment outputs (S) byte1 <table border="1"> <tr> <td></td> <td>n</td> <td>n+1</td> <td>n+2</td> <td>n+3</td> <td>n+4</td> <td>n+5</td> <td>n+6</td> <td>n+7</td> </tr> <tr> <td>display RAM bits (rows)/backplane outputs (BP)</td> <td>0</td> <td>c</td> <td>b</td> <td>a</td> <td>f</td> <td>g</td> <td>e</td> <td>d</td> <td>DP</td> </tr> <tr> <td>1</td> <td>x</td> <td>x</td> <td>x</td> <td>x</td> <td>x</td> <td>x</td> <td>x</td> <td>x</td> <td>x</td> </tr> <tr> <td>2</td> <td>x</td> <td>x</td> <td>x</td> <td>x</td> <td>x</td> <td>x</td> <td>x</td> <td>x</td> <td>x</td> </tr> <tr> <td>3</td> <td>x</td> <td>x</td> <td>x</td> <td>x</td> <td>x</td> <td>x</td> <td>x</td> <td>x</td> <td>x</td> </tr> </table>		n	n+1	n+2	n+3	n+4	n+5	n+6	n+7	display RAM bits (rows)/backplane outputs (BP)	0	c	b	a	f	g	e	d	DP	1	x	x	x	x	x	x	x	x	x	2	x	x	x	x	x	x	x	x	x	3	x	x	x	x	x	x	x	x	x	MSB LSB <table border="1"> <tr> <td>c</td> <td>b</td> <td>a</td> <td>f</td> <td>g</td> <td>e</td> <td>d</td> <td>DP</td> </tr> </table>	c	b	a	f	g	e	d	DP
	n	n+1	n+2	n+3	n+4	n+5	n+6	n+7																																																					
display RAM bits (rows)/backplane outputs (BP)	0	c	b	a	f	g	e	d	DP																																																				
1	x	x	x	x	x	x	x	x	x																																																				
2	x	x	x	x	x	x	x	x	x																																																				
3	x	x	x	x	x	x	x	x	x																																																				
c	b	a	f	g	e	d	DP																																																						
1:2 multiplex			display RAM addresses (columns)/segment outputs (S) byte1 <table border="1"> <tr> <td></td> <td>n</td> <td>n+1</td> <td>n+2</td> <td>n+3</td> </tr> <tr> <td>display RAM bits (rows)/backplane outputs (BP)</td> <td>0</td> <td>a</td> <td>f</td> <td>e</td> <td>d</td> </tr> <tr> <td>1</td> <td>b</td> <td>g</td> <td>c</td> <td>DP</td> <td></td> </tr> <tr> <td>2</td> <td>x</td> <td>x</td> <td>x</td> <td>x</td> <td></td> </tr> <tr> <td>3</td> <td>x</td> <td>x</td> <td>x</td> <td>x</td> <td></td> </tr> </table>		n	n+1	n+2	n+3	display RAM bits (rows)/backplane outputs (BP)	0	a	f	e	d	1	b	g	c	DP		2	x	x	x	x		3	x	x	x	x		MSB LSB <table border="1"> <tr> <td>a</td> <td>b</td> <td>f</td> <td>g</td> <td>e</td> <td>c</td> <td>d</td> <td>DP</td> </tr> </table>	a	b	f	g	e	c	d	DP																				
	n	n+1	n+2	n+3																																																									
display RAM bits (rows)/backplane outputs (BP)	0	a	f	e	d																																																								
1	b	g	c	DP																																																									
2	x	x	x	x																																																									
3	x	x	x	x																																																									
a	b	f	g	e	c	d	DP																																																						
1:3 multiplex			display RAM addresses (columns)/segment outputs (S) byte1 <table border="1"> <tr> <td></td> <td>n</td> <td>n+1</td> <td>n+2</td> </tr> <tr> <td>display RAM bits (rows)/backplane outputs (BP)</td> <td>0</td> <td>b</td> <td>a</td> <td>f</td> </tr> <tr> <td>1</td> <td>DP</td> <td>d</td> <td>e</td> <td></td> </tr> <tr> <td>2</td> <td>c</td> <td>g</td> <td>x</td> <td></td> </tr> <tr> <td>3</td> <td>x</td> <td>x</td> <td>x</td> <td></td> </tr> </table>		n	n+1	n+2	display RAM bits (rows)/backplane outputs (BP)	0	b	a	f	1	DP	d	e		2	c	g	x		3	x	x	x		MSB LSB <table border="1"> <tr> <td>b</td> <td>DP</td> <td>c</td> <td>a</td> <td>d</td> <td>g</td> <td>f</td> <td>e</td> </tr> </table>	b	DP	c	a	d	g	f	e																									
	n	n+1	n+2																																																										
display RAM bits (rows)/backplane outputs (BP)	0	b	a	f																																																									
1	DP	d	e																																																										
2	c	g	x																																																										
3	x	x	x																																																										
b	DP	c	a	d	g	f	e																																																						
1:4 multiplex			display RAM addresses (columns)/segment outputs (S) byte1 <table border="1"> <tr> <td></td> <td>n</td> <td>n+1</td> </tr> <tr> <td>display RAM bits (rows)/backplane outputs (BP)</td> <td>0</td> <td>a</td> <td>f</td> </tr> <tr> <td>1</td> <td>c</td> <td>e</td> <td></td> </tr> <tr> <td>2</td> <td>b</td> <td>g</td> <td></td> </tr> <tr> <td>3</td> <td>DP</td> <td>d</td> <td></td> </tr> </table>		n	n+1	display RAM bits (rows)/backplane outputs (BP)	0	a	f	1	c	e		2	b	g		3	DP	d		MSB LSB <table border="1"> <tr> <td>a</td> <td>c</td> <td>b</td> <td>DP</td> <td>f</td> <td>e</td> <td>g</td> <td>d</td> </tr> </table>	a	c	b	DP	f	e	g	d																														
	n	n+1																																																											
display RAM bits (rows)/backplane outputs (BP)	0	a	f																																																										
1	c	e																																																											
2	b	g																																																											
3	DP	d																																																											
a	c	b	DP	f	e	g	d																																																						

001aaj646

x = data bit unchanged.

Fig 10. Relationship between LCD layout, drive mode, display RAM filling order and display data transmitted over the I²C-bus

7.11 Data pointer

The addressing mechanism for the display RAM is realized using the data pointer.

This allows the loading of an individual display data byte, or a series of display data bytes, into any location of the display RAM. The sequence commences with the initialization of the data pointer by the load-data-pointer command (see [Section 7.17](#)).

Following this command, an arriving data byte is stored at the display RAM address indicated by the data pointer. The filling order shown in [Figure 10](#).

After each byte is stored, the contents of the data pointer is automatically incremented by a value dependent on the selected LCD drive mode:

- In static drive mode by eight
- In 1:2 multiplex drive mode by four
- In 1:3 multiplex drive mode by three
- In 1:4 multiplex drive mode by two

If an I²C-bus data access is terminated early then the state of the data pointer is unknown. The data pointer should be re-written prior to further RAM accesses.

7.12 Subaddress counter

The storage of display data is determined by the contents of the subaddress counter. Storage is allowed to take place only when the contents of the subaddress counter agree with the hardware subaddress applied to A0, A1 and A2. The subaddress counter value is defined by the device-select command (see [Section 7.17](#)). If the contents of the subaddress counter and the hardware subaddress do not agree then data storage is inhibited but the data pointer is incremented as if data storage had taken place. The subaddress counter is also incremented when the data pointer overflows.

The hardware subaddress must not be changed while the device is being accessed on the I²C-bus interface.

7.13 Output bank selector

The output bank selector selects one of the four rows per display RAM address for transfer to the display register. The actual row selected depends on the particular LCD drive mode in operation and on the instant in the multiplex sequence.

- In 1:4 multiplex mode, all RAM addresses of row 0 are selected, these are followed by the contents of row 1, row 2 and then row 3.
- In 1:3 multiplex mode, row 0, 1 and 2 are selected sequentially
- In 1:2 multiplex mode, row 0 and 1 are selected
- In static mode, row 0 is selected

The PCF8562 includes a RAM bank switching feature in the static and 1:2 drive modes. In the static drive mode, the bank-select command (see [Section 7.17](#)) may request the contents of row 2 to be selected for display instead of the contents of row 0. In 1:2 mode, the contents of rows 2 and 3 may be selected instead of rows 0 and 1. This gives the provision for preparing display information in an alternative bank and to be able to switch to it once it is assembled.

7.14 Input bank selector

The input bank selector loads display data into the display RAM in accordance with the selected LCD drive configuration.

The bank-select command (see [Section 7.17](#)) can be used to load display data in row 2 in static drive mode or in rows 2 and 3 in 1:2 mode. The input bank selector functions are independent of the output bank selector.

7.15 Blinker

The PCF8562 has a very versatile display blinking capability. The whole display can blink at a frequency selected by the blink-select command (see [Table 13](#)). Each blink frequency is a fraction of the clock frequency; the ratio between the clock frequency and blink frequency depends on the blink mode selected (see [Table 6](#)).

An additional feature allows an arbitrary selection of LCD segments to blink in the static and 1:2 drive modes. This is implemented without any communication overheads by the output bank selector which alternates the displayed data between the data in the display RAM bank and the data in an alternative RAM bank at the blink frequency. This mode can also be implemented by the blink-select command (see [Section 7.17](#)).

In the 1:3 and 1:4 drive modes, where no alternative RAM bank is available, groups of LCD segments can blink selectively by changing the display RAM data at fixed time intervals.

The entire display can blink at a frequency other than the nominal blink frequency by sequentially resetting and setting the display enable bit E at the required rate using the mode-set command (see [Section 7.17](#)).

Table 6. Blinking frequencies^[1]

Blink mode	Normal operating mode ratio	Nominal blink frequency
off	-	blinking off
1	$\frac{f_{clk}}{768}$	2 Hz
2	$\frac{f_{clk}}{1536}$	1 Hz
3	$\frac{f_{clk}}{3072}$	0.5 Hz

[1] Blink modes 1, 2 and 3 and the nominal blink frequencies 0.5 Hz, 1 Hz and 2 Hz correspond to an oscillator frequency (f_{clk}) of 1536 Hz (see [Section 11](#)).

7.16 Characteristics of the I²C-bus

The I²C-bus is for bidirectional, two-line communication between different ICs or modules. The two lines are a Serial Data Line (SDA) and a Serial Clock Line (SCL). Both lines must be connected to a positive supply via a pull-up resistor when connected to the output stages of a device. Data transfer may be initiated only when the bus is not busy.

7.16.1 Bit transfer

One data bit is transferred during each clock pulse. The data on the SDA line must remain stable during the HIGH period of the clock pulse as changes in the data line at this time will be interpreted as a control signal (see [Figure 11](#)).

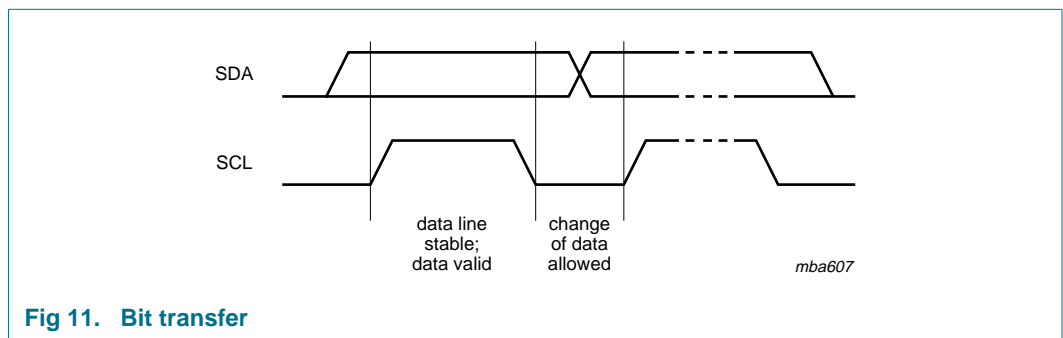

Fig 11. Bit transfer

7.16.2 START and STOP conditions

Both data and clock lines remain HIGH when the bus is not busy.

A HIGH-to-LOW transition of the data line while the clock is HIGH is defined as the START condition - S.

A LOW-to-HIGH transition of the data line while the clock is HIGH is defined as the STOP condition - P (see [Figure 12](#)).

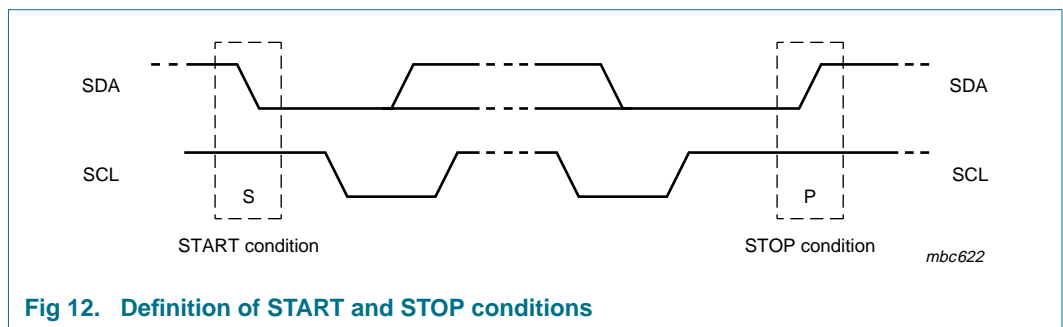

Fig 12. Definition of START and STOP conditions

7.16.3 System configuration

A device generating a message is a transmitter, a device receiving a message is the receiver. The device that controls the message is the master and the devices which are controlled by the master are the slaves (see [Figure 13](#)).

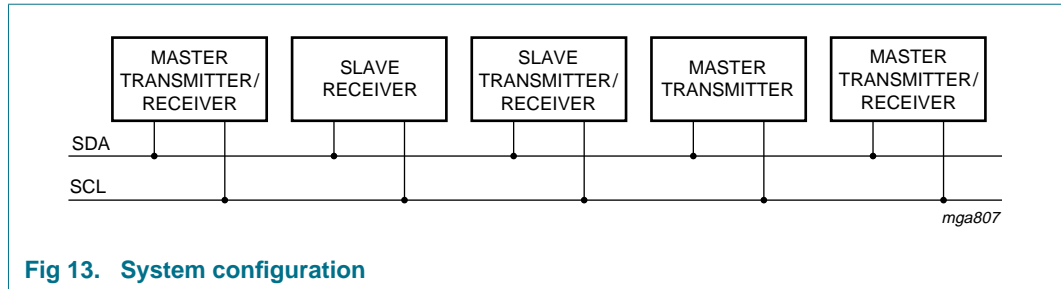

Fig 13. System configuration

7.16.4 Acknowledge

The number of data bytes that can be transferred from transmitter to receiver between the START and STOP conditions is unlimited. Each byte of eight bits is followed by an acknowledge bit. The acknowledge bit is a HIGH-level signal on the bus that is asserted by the transmitter during which time the master generates an extra acknowledge related clock pulse. An addressed slave receiver must generate an acknowledge after receiving each byte. Also a master receiver must generate an acknowledge after receiving each byte that has been clocked out of the slave transmitter. The acknowledging device must pull-down the SDA line during the acknowledge clock pulse so that the SDA line is stable LOW during the HIGH period of the acknowledge related clock pulse (set-up and hold times must be taken into consideration). A master receiver must signal an end of data to the transmitter by not generating an acknowledge on the last byte that has been clocked out of the slave. In this event the transmitter must leave the data line HIGH to enable the master to generate a STOP condition (see Figure 14).

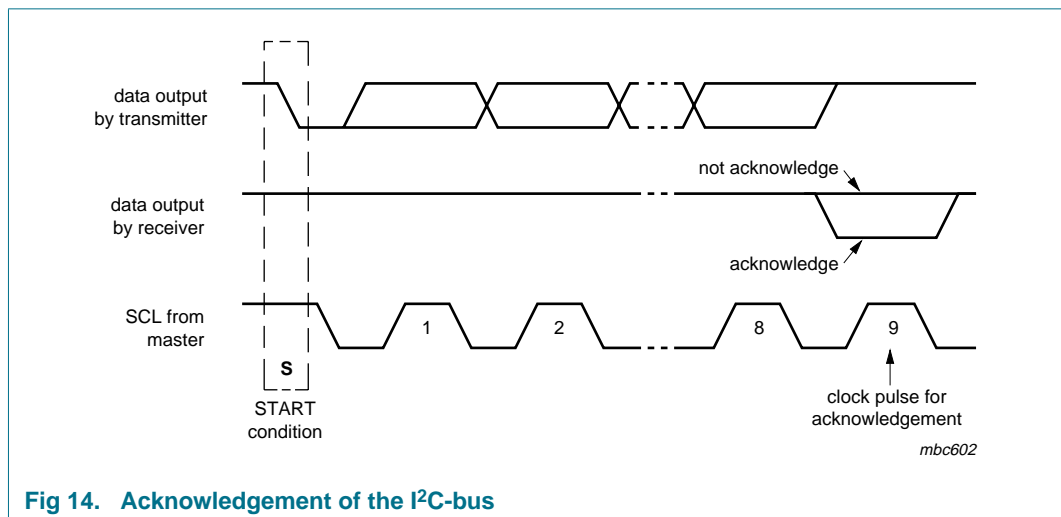

Fig 14. Acknowledgement of the I²C-bus

7.16.5 I²C-bus controller

The PCF8562 acts as an I²C-bus slave receiver. It does not initiate I²C-bus transfers or transmit data to an I²C-bus master receiver. The only data output from the PCF8562 are the acknowledge signals of the selected devices. Device selection depends on the I²C-bus slave address, on the transferred command data and on the hardware subaddress.

7.16.6 Input filters

To enhance noise immunity in electrically adverse environments, RC low-pass filters are provided on the SDA and SCL lines.

7.16.7 I²C-bus protocol

Two I²C-bus slave addresses (0111 000 and 0111 001) are reserved for the PCF8562. The least significant bit of the slave address that a PCF8562 will respond to is defined by the level tied to its SA0 input. The PCF8562 is a write-only device and will not respond to a read access.

The I²C-bus protocol is shown in Figure 15. The sequence is initiated with a START condition (S) from the I²C-bus master which is followed by one of two possible PCF8562 slave addresses available. All PCF8562s whose SA0 inputs correspond to bit 0 of the slave address respond by asserting an acknowledge in parallel. This I²C-bus transfer is ignored by all PCF8562s whose SA0 inputs are set to the alternative level.

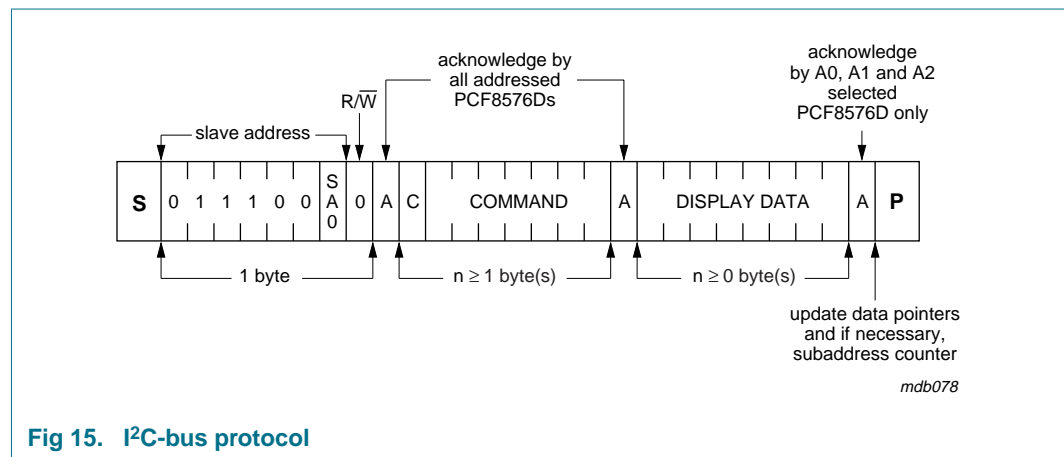

Fig 15. I²C-bus protocol

After an acknowledgement, one or more command bytes follow, that define the status of each addressed PCF8562.

The last command byte sent is identified by resetting its most significant bit, continuation bit C, (see Figure 16). The command bytes are also acknowledged by all addressed PCF8562s on the bus.

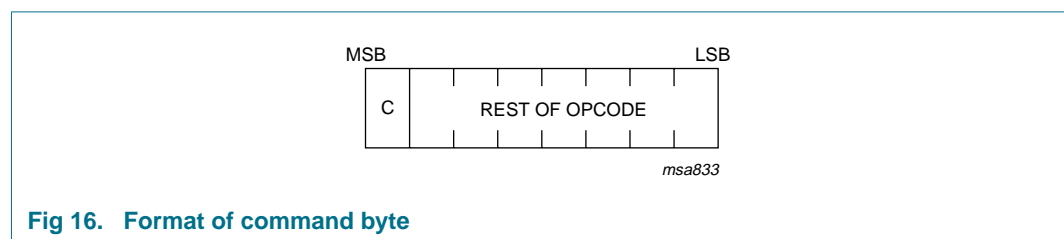

Fig 16. Format of command byte

After the last command byte, one or more display data bytes may follow. Display data bytes are stored in the display RAM at the address specified by the data pointer and the subaddress counter. Both data pointer and subaddress counter are automatically updated.

An acknowledgement after each byte is asserted only by the PCF8562s that are addressed via address lines A0, A1 and A2. After the last display byte, the I²C-bus master asserts a STOP condition (P). Alternately a START may be asserted to restart an I²C-bus access.

7.17 Command decoder

The command decoder identifies command bytes that arrive on the I²C-bus.

The commands available to the PCF8562 are defined in [Table 7](#).

Table 7. Definition of PCF8562 commands

Command	Operation Code								Reference
	7	6	5	4	3	2	1	0	
mode-set	C	1	0	[1]	E	B	M1	M0	Table 9
load-data-pointer	C	0	0	P4	P3	P2	P1	P0	Table 10
device-select	C	1	1	0	0	A2	A1	A0	Table 11
bank-select	C	1	1	1	1	0	I	O	Table 12
blink-select	C	1	1	1	0	A	BF1	BF0	Table 13

[1] Not used.

All available commands carry a continuation bit C in their most significant bit position as shown in [Figure 16](#). When this bit is set, it indicates that the next byte of the transfer to arrive will also represent a command. If this bit is reset, it indicates that the command byte is the last in the transfer. Further bytes will be regarded as display data (see [Table 8](#)).

Table 8. C bit description

Bit	Symbol	Value	Description
7	C		continue bit
		0	last control byte in the transfer; next byte will be regarded as display data
		1	control bytes continue; next byte will be a command too

Table 9. Mode-set command bits description

Bit	Symbol	Value	Description
7	C	0, 1	see Table 8
6, 5	-	10	fixed value
4	-	-	unused
3	E		display status
		0	disabled (blank) ^[1]
		1	enabled
2	B		LCD bias configuration
		0	$\frac{1}{3}$ bias
		1	$\frac{1}{2}$ bias
1 to 0	M[1:0]		LCD drive mode selection
		01	static; BP0
		10	1:2 multiplex; BP0, BP1
		11	1:3 multiplex; BP0, BP1, BP2
		00	1:4 multiplex; BP0, BP1, BP2, BP3

[1] The possibility to disable the display allows implementation of blinking under external control.

Table 10. Load-data-pointer command bits description

Bit	Symbol	Value	Description
7	C	0, 1	see Table 8
6, 5	-	00	fixed value
4 to 0	P[4:0]	00000 to 11111	5 bit binary value, 0 to 31; transferred to the data pointer to define one of 32 display RAM addresses

Table 11. Device-select command bits description

Bit	Symbol	Value	Description
7	C	0, 1	see Table 8
6 to 3	-	1100	fixed value
2 to 0	A[2:0]	000 to 111	3 bit binary value, 0 to 7; transferred to the subaddress counter to define one of eight hardware subaddresses

Table 12. Bank-select command bits description

Bit	Symbol	Value	Description	
			Static	1:2 multiplex ^[1]
7	C	0, 1	see Table 8	
6 to 2	-	11110	fixed value	
1	I		input bank selection ; storage of arriving display data	
		0	RAM bit 0	RAM bits 0 and 1
		1	RAM bit 2	RAM bits 2 and 3
0	O		output bank selection ; retrieval of LCD display data	
		0	RAM bit 0	RAM bits 0 and 1
		1	RAM bit 2	RAM bits 2 and 3

[1] The bank-select command has no effect in 1:3 and 1:4 multiplex drive modes.

Table 13. Blink-select command bits description

Bit	Symbol	Value	Description
7	C	0, 1	see Table 8
6 to 3	-	1110	fixed value
2	A		blink mode selection
		0	normal blinking ^[1]
		1	alternate RAM bank blinking ^[2]
1 to 0	BF[1:0]		blink frequency selection
		00	off
		01	1
		10	2
		11	3

[1] Normal blinking is assumed when the LCD multiplex drive modes 1:3 or 1:4 are selected.

[2] Alternating RAM bank blinking does not apply in 1:3 and 1:4 multiplex drive modes.

7.18 Display controller

The display controller executes the commands identified by the command decoder. It contains the device's status registers and coordinates their effects. The display controller is also responsible for loading display data into the display RAM in the correct filling order.

7.19 Multiple chip operation

For large display configurations or for more segments (> 128 elements) to drive please refer to the PCF8576D device.

The contact resistance between the $\overline{\text{SYNC}}$ input/output on each cascaded device must be controlled. If the resistance is too high, the device will not be able to synchronize properly; this is particularly applicable to chip-on-glass applications. The maximum $\overline{\text{SYNC}}$ contact resistance allowed for the number of devices in cascade is given in [Table 14](#).

Table 14. SYNC contact resistance

Number of devices	Maximum contact resistance
2	6000 Ω
3 to 5	2200 Ω
6 to 10	1200 Ω
10 to 16	700 Ω

8. Internal circuitry

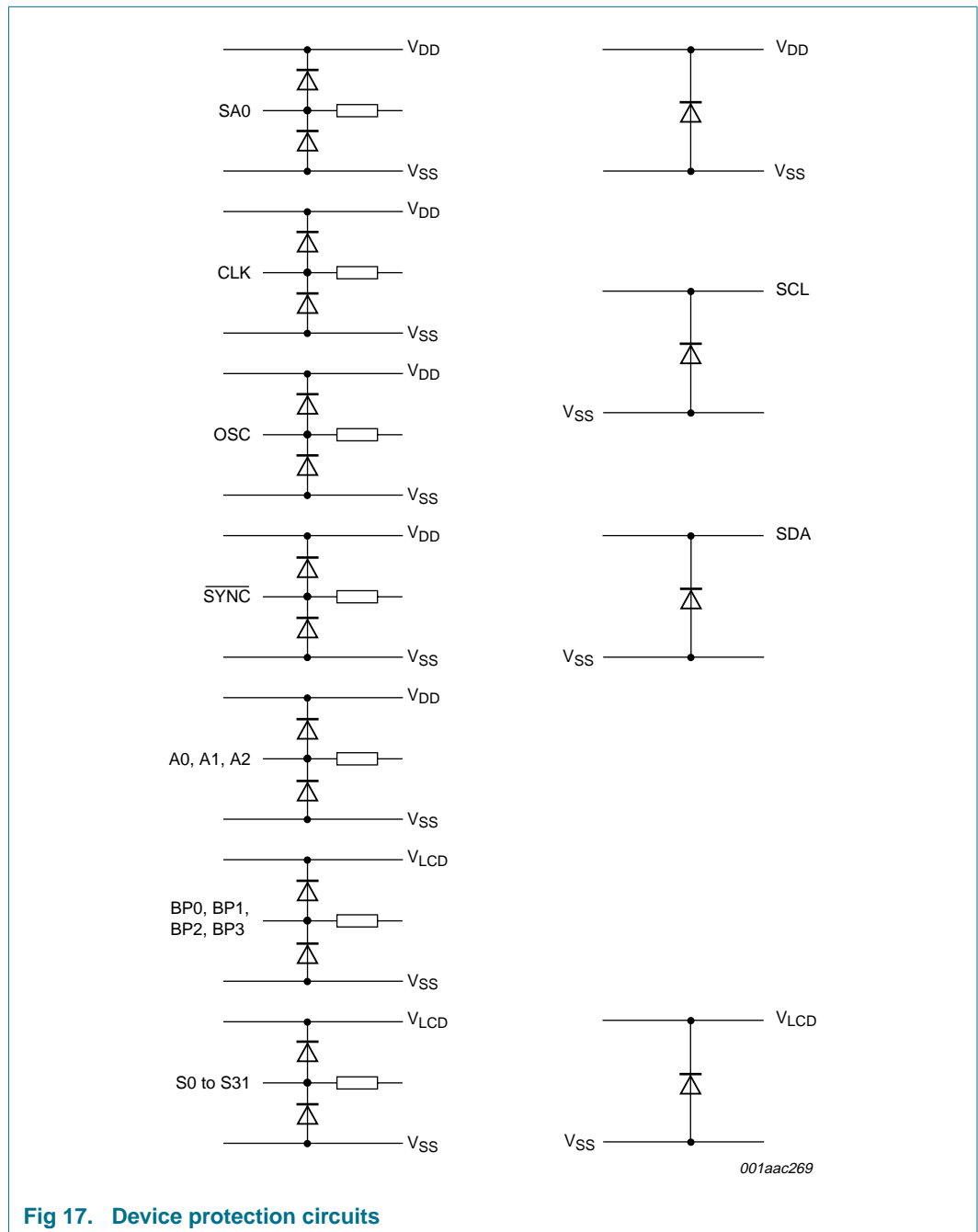

Fig 17. Device protection circuits

9. Limiting values

CAUTION



Static voltages across the liquid crystal display can build up when the LCD supply voltage (V_{LCD}) is on while the IC supply voltage (V_{DD}) is off, or vice versa. This may cause unwanted display artifacts. To avoid such artifacts, V_{LCD} and V_{DD} must be applied or removed together.

Table 15. Limiting values

In accordance with the Absolute Maximum Rating System (IEC 60134).

Symbol	Parameter	Conditions	Min	Max	Unit	
V_{DD}	supply voltage		-0.5	6.5	V	
V_{LCD}	LCD supply voltage		-0.5	+7.5	V	
V_I	input voltage	on each of the pins CLK, SDA, SCL, SYNC, SA0, OSC, A0 to A2	-0.5	+6.5	V	
V_O	output voltage	on each of the pins S0 to S31, BP0 to BP3	-0.5	+7.5	V	
I_I	input current		-10	+10	mA	
I_O	output current		-10	+10	mA	
I_{DD}	supply current		-50	+50	mA	
$I_{DD(LCD)}$	LCD supply current		-50	+50	mA	
I_{SS}	ground supply current		-50	+50	mA	
P_{tot}	total power dissipation		-	400	mW	
P_o	output power		-	100	mW	
V_{esd}	electrostatic discharge voltage	HBM	[1]	-	±2000	V
		MM	[2]	-	±200	V
		CDM	[3]	-	±2000	V
I_{lu}	latch-up current		[4]	-	100	mA
T_{stg}	storage temperature		[5]	-65	+150	°C

[1] Pass level; Human Body Model (HBM) according to JESD22-A114.

[2] Pass level; Machine Model (MM), according to JESD22-A115.

[3] Pass level; Charged-Device Model (CDM), according to JESD22-C101.

[4] Pass level; latch-up testing, according to JESD78.

[5] According to the NXP store and transport conditions (document *SNW-SQ-623*) the devices have to be stored at a temperature of +5 °C to +45 °C and a humidity of 25 % to 75 %.

10. Static characteristics

Table 16. Static characteristics

$V_{DD} = 1.8\text{ V to }5.5\text{ V}$; $V_{SS} = 0\text{ V}$; $V_{LCD} = 2.5\text{ V to }6.5\text{ V}$; $T_{amb} = -40\text{ }^{\circ}\text{C to }+85\text{ }^{\circ}\text{C}$; unless otherwise specified.

Symbol	Parameter	Conditions	Min	Typ	Max	Unit
Supplies						
V_{DD}	supply voltage		1.8	-	5.5	V
V_{LCD}	LCD supply voltage		[1]	-	6.5	V
I_{DD}	supply current	$f_{clk} = 1536\text{ Hz}$	[2]	8	20	μA
$I_{DD(LCD)}$	LCD supply current	$f_{clk} = 1536\text{ Hz}$	[2]	24	60	μA
Logic						
$V_{P(POR)}$	power-on reset supply voltage		1.0	1.3	1.6	V
V_{IL}	LOW-level input voltage	on pins CLK, $\overline{\text{SYNC}}$, OSC, A0 to A2, SA0, SCL, SDA	V_{SS}	-	$0.3V_{DD}$	V
V_{IH}	HIGH-level input voltage	on pins CLK, $\overline{\text{SYNC}}$, OSC, A0 to A2, SA0, SCL, SDA	[3][4]	$0.7V_{DD}$	-	V_{DD}
I_{OL}	LOW-level output current	$V_{OL} = 0.4\text{ V}$; $V_{DD} = 5\text{ V}$				
		on pins CLK and $\overline{\text{SYNC}}$	1	-	-	mA
		on pin SDA	3	-	-	mA
$I_{OH(CLK)}$	HIGH-level output current on pin CLK	$V_{OH} = 4.6\text{ V}$; $V_{DD} = 5\text{ V}$	-1	-	-	mA
I_L	leakage current	$V_I = V_{DD}$ or V_{SS} ; on pins CLK, SCL, SDA, A0 to A2 and SA0	-1	-	+1	μA
$I_{L(OSC)}$	leakage current on pin OSC	$V_I = V_{DD}$	-1	-	+1	μA
C_I	input capacitance		[5]	-	7	pF
LCD outputs						
ΔV_O	output voltage variation	on pins BP0 to BP3 and S0 to S31	-100	-	+100	mV
R_O	output resistance	$V_{LCD} = 5\text{ V}$	[6]			
		on pins BP0 to BP3	-	1.5	-	k Ω
		on pins S0 to S31	-	6.0	-	k Ω

[1] $V_{LCD} > 3\text{ V}$ for $\frac{1}{3}$ bias.

[2] LCD outputs are open-circuit; inputs at V_{SS} or V_{DD} ; external clock with 50 % duty factor; I²C-bus inactive.

[3] When tested, I²C pins SCL and SDA have no diode to V_{DD} and may be driven to the V_I limiting values given in Table 15 (see Figure 17 too).

[4] Propagation delay of driver between clock (CLK) and LCD driving signals.

[5] Periodically sampled, not 100 % tested.

[6] Outputs measured one at a time.

11. Dynamic characteristics

Table 17. Dynamic characteristics

$V_{DD} = 1.8\text{ V to }5.5\text{ V}$; $V_{SS} = 0\text{ V}$; $V_{LCD} = 2.5\text{ V to }6.5\text{ V}$; $T_{amb} = -40\text{ }^{\circ}\text{C to }+85\text{ }^{\circ}\text{C}$; unless otherwise specified.

Symbol	Parameter	Conditions	Min	Typ	Max	Unit
Clock						
$f_{\text{clk(int)}}$	internal clock frequency	[1]	1440	1850	2640	Hz
$f_{\text{clk(ext)}}$	external clock frequency		960	-	2640	Hz
$t_{\text{clk(H)}}$	HIGH-level clock time		60	-	-	μs
$t_{\text{clk(L)}}$	LOW-level clock time		60	-	-	μs
Synchronization						
$t_{\text{PD(SYNC_N)}}$	$\overline{\text{SYNC}}$ propagation delay		-	30	-	ns
$t_{\text{SYNC_NL}}$	$\overline{\text{SYNC}}$ LOW time		1	-	-	μs
$t_{\text{PD(drv)}}$	driver propagation delay	$V_{\text{LCD}} = 5\text{ V}$ [2]	-	-	30	μs
I²C-bus[3]						
Pin SCL						
f_{SCL}	SCL clock frequency		-	-	400	kHz
t_{LOW}	LOW period of the SCL clock		1.3	-	-	μs
t_{HIGH}	HIGH period of the SCL clock		0.6	-	-	μs
Pin SDA						
$t_{\text{SU;DAT}}$	data set-up time		100	-	-	ns
$t_{\text{HD;DAT}}$	data hold time		0	-	-	ns
Pins SCL and SDA						
t_{BUF}	bus free time between a STOP and START condition		1.3	-	-	μs
$t_{\text{SU;STO}}$	set-up time for STOP condition		0.6	-	-	μs
$t_{\text{HD;STA}}$	hold time (repeated) START condition		0.6	-	-	μs
$t_{\text{SU;STA}}$	set-up time for a repeated START condition		0.6	-	-	μs
t_{r}	rise time of both SDA and SCL signals	$f_{\text{SCL}} = 400\text{ kHz}$	-	-	0.3	μs
		$f_{\text{SCL}} < 125\text{ kHz}$	-	-	1.0	μs
t_{f}	fall time of both SDA and SCL signals		-	-	0.3	μs
C_{b}	capacitive load for each bus line		-	-	400	pF
$t_{\text{w(spike)}}$	spike pulse width	on the I ² C-bus	-	-	50	ns

[1] Typical output duty factor: 50 % measured at the CLK output pin.

[2] Not tested in production.

[3] All timing values are valid within the operating supply voltage and ambient temperature range and are referenced to V_{IL} and V_{IH} with an input voltage swing of V_{SS} to V_{DD} .

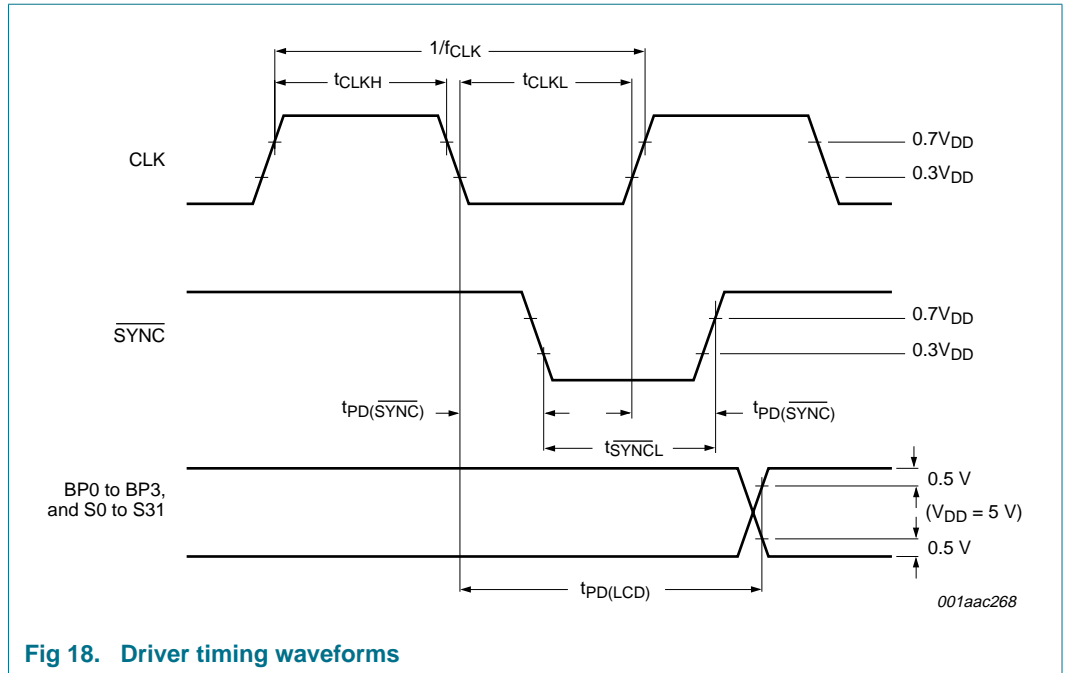

Fig 18. Driver timing waveforms

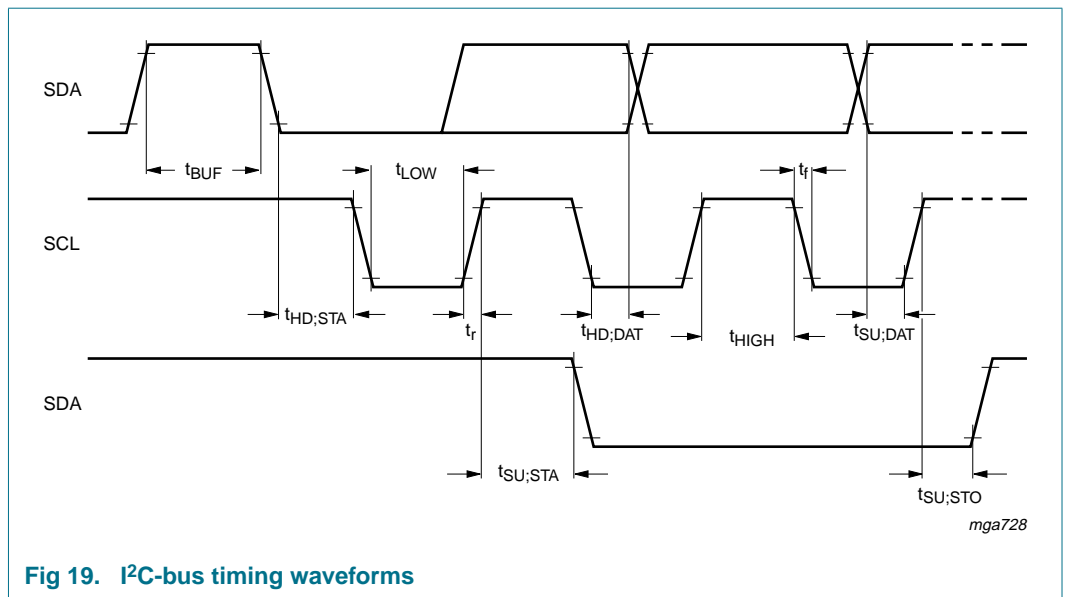

Fig 19. I²C-bus timing waveforms

12. Package outline

TSSOP48: plastic thin shrink small outline package; 48 leads; body width 6.1 mm

SOT362-1

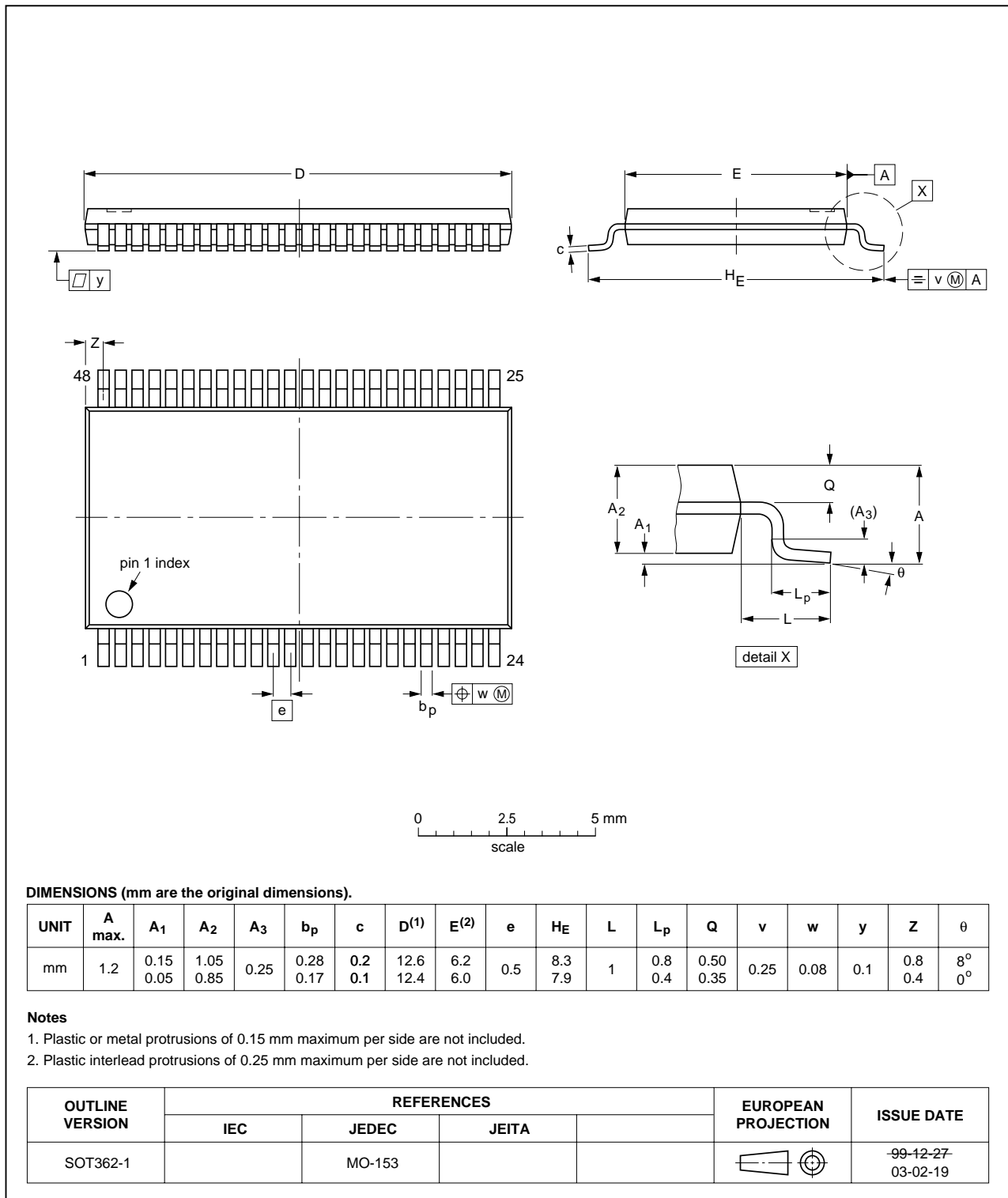

Fig 20. Package outline SOT362-1 (TSSOP48)

13. Handling information

All input and output pins are protected against ElectroStatic Discharge (ESD) under normal handling. When handling Metal-Oxide Semiconductor (MOS) devices ensure that all normal precautions are taken as described in *JESD625-A*, *IEC 61340-5* or equivalent standards.

14. Soldering of SMD packages

This text provides a very brief insight into a complex technology. A more in-depth account of soldering ICs can be found in Application Note *AN10365 "Surface mount reflow soldering description"*.

14.1 Introduction to soldering

Soldering is one of the most common methods through which packages are attached to Printed Circuit Boards (PCBs), to form electrical circuits. The soldered joint provides both the mechanical and the electrical connection. There is no single soldering method that is ideal for all IC packages. Wave soldering is often preferred when through-hole and Surface Mount Devices (SMDs) are mixed on one printed wiring board; however, it is not suitable for fine pitch SMDs. Reflow soldering is ideal for the small pitches and high densities that come with increased miniaturization.

14.2 Wave and reflow soldering

Wave soldering is a joining technology in which the joints are made by solder coming from a standing wave of liquid solder. The wave soldering process is suitable for the following:

- Through-hole components
- Leaded or leadless SMDs, which are glued to the surface of the printed circuit board

Not all SMDs can be wave soldered. Packages with solder balls, and some leadless packages which have solder lands underneath the body, cannot be wave soldered. Also, leaded SMDs with leads having a pitch smaller than ~0.6 mm cannot be wave soldered, due to an increased probability of bridging.

The reflow soldering process involves applying solder paste to a board, followed by component placement and exposure to a temperature profile. Leaded packages, packages with solder balls, and leadless packages are all reflow solderable.

Key characteristics in both wave and reflow soldering are:

- Board specifications, including the board finish, solder masks and vias
- Package footprints, including solder thieves and orientation
- The moisture sensitivity level of the packages
- Package placement
- Inspection and repair
- Lead-free soldering versus SnPb soldering

14.3 Wave soldering

Key characteristics in wave soldering are:

- Process issues, such as application of adhesive and flux, clinching of leads, board transport, the solder wave parameters, and the time during which components are exposed to the wave
- Solder bath specifications, including temperature and impurities

14.4 Reflow soldering

Key characteristics in reflow soldering are:

- Lead-free versus SnPb soldering; note that a lead-free reflow process usually leads to higher minimum peak temperatures (see [Figure 21](#)) than a SnPb process, thus reducing the process window
- Solder paste printing issues including smearing, release, and adjusting the process window for a mix of large and small components on one board
- Reflow temperature profile; this profile includes preheat, reflow (in which the board is heated to the peak temperature) and cooling down. It is imperative that the peak temperature is high enough for the solder to make reliable solder joints (a solder paste characteristic). In addition, the peak temperature must be low enough that the packages and/or boards are not damaged. The peak temperature of the package depends on package thickness and volume and is classified in accordance with [Table 18](#) and [19](#)

Table 18. SnPb eutectic process (from J-STD-020C)

Package thickness (mm)	Package reflow temperature (°C)	
	Volume (mm ³)	
	< 350	≥ 350
< 2.5	235	220
≥ 2.5	220	220

Table 19. Lead-free process (from J-STD-020C)

Package thickness (mm)	Package reflow temperature (°C)		
	Volume (mm ³)		
	< 350	350 to 2000	> 2000
< 1.6	260	260	260
1.6 to 2.5	260	250	245
> 2.5	250	245	245

Moisture sensitivity precautions, as indicated on the packing, must be respected at all times.

Studies have shown that small packages reach higher temperatures during reflow soldering, see [Figure 21](#).

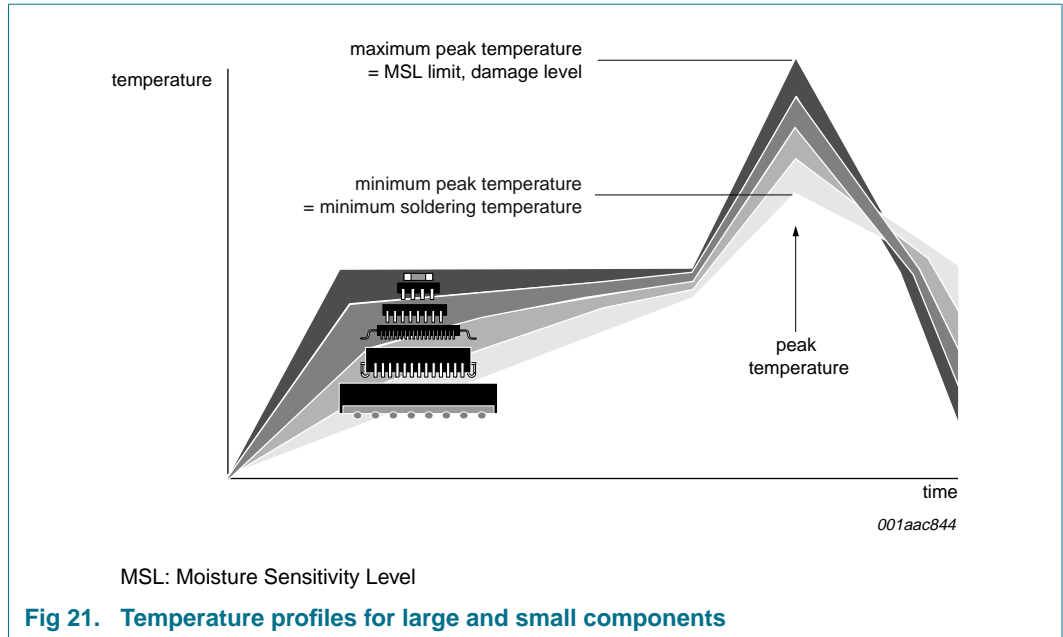

For further information on temperature profiles, refer to Application Note AN10365 “Surface mount reflow soldering description”.

15. Abbreviations

Table 20. Abbreviations

Acronym	Description
CMOS	Complementary Metal Oxide Semiconductor
CDM	Charged-Device Model
HBM	Human Body Model
ITO	Indium Tin Oxide
LCD	Liquid Crystal Display
LSB	Least Significant Bit
MM	Machine Model
MSB	Most Significant Bit
MSL	Moisture Sensitivity Level
PCB	Printed Circuit Board
RAM	Random Access Memory
RMS	Root Mean Square
SCL	Serial Clock Line
SDA	Serial Data Line
SMD	Surface Mount Device

16. Revision history

Table 21. Revision history

Document ID	Release date	Data sheet status	Change notice	Supersedes
PCF8562_4	20090318	Product data sheet	-	PCF8562_3
Modifications:	<ul style="list-style-type: none">• The typical value of the frame frequency has been corrected (see Table 17)			
PCF8562_3	20081202	Product data sheet	-	PCF8562_2
Modifications:	<ul style="list-style-type: none">• The format of this data sheet has been redesigned to comply with the new identity guidelines of NXP Semiconductors.• Legal texts have been adapted to the new company name where appropriate.• Added AEC-Q100 qualification			
PCF8562_2	20070122	Product data sheet	-	PCF8562_1
PCF8562_1	20050801	Product data sheet	-	-

17. Legal information

17.1 Data sheet status

Document status ^{[1][2]}	Product status ^[3]	Definition
Objective [short] data sheet	Development	This document contains data from the objective specification for product development.
Preliminary [short] data sheet	Qualification	This document contains data from the preliminary specification.
Product [short] data sheet	Production	This document contains the product specification.

[1] Please consult the most recently issued document before initiating or completing a design.

[2] The term 'short data sheet' is explained in section "Definitions".

[3] The product status of device(s) described in this document may have changed since this document was published and may differ in case of multiple devices. The latest product status information is available on the Internet at URL <http://www.nxp.com>.

17.2 Definitions

Draft — The document is a draft version only. The content is still under internal review and subject to formal approval, which may result in modifications or additions. NXP Semiconductors does not give any representations or warranties as to the accuracy or completeness of information included herein and shall have no liability for the consequences of use of such information.

Short data sheet — A short data sheet is an extract from a full data sheet with the same product type number(s) and title. A short data sheet is intended for quick reference only and should not be relied upon to contain detailed and full information. For detailed and full information see the relevant full data sheet, which is available on request via the local NXP Semiconductors sales office. In case of any inconsistency or conflict with the short data sheet, the full data sheet shall prevail.

17.3 Disclaimers

General — Information in this document is believed to be accurate and reliable. However, NXP Semiconductors does not give any representations or warranties, expressed or implied, as to the accuracy or completeness of such information and shall have no liability for the consequences of use of such information.

Right to make changes — NXP Semiconductors reserves the right to make changes to information published in this document, including without limitation specifications and product descriptions, at any time and without notice. This document supersedes and replaces all information supplied prior to the publication hereof.

Suitability for use — NXP Semiconductors products are not designed, authorized or warranted to be suitable for use in medical, military, aircraft, space or life support equipment, nor in applications where failure or malfunction of an NXP Semiconductors product can reasonably be expected to result in personal injury, death or severe property or environmental

damage. NXP Semiconductors accepts no liability for inclusion and/or use of NXP Semiconductors products in such equipment or applications and therefore such inclusion and/or use is at the customer's own risk.

Applications — Applications that are described herein for any of these products are for illustrative purposes only. NXP Semiconductors makes no representation or warranty that such applications will be suitable for the specified use without further testing or modification.

Limiting values — Stress above one or more limiting values (as defined in the Absolute Maximum Ratings System of IEC 60134) may cause permanent damage to the device. Limiting values are stress ratings only and operation of the device at these or any other conditions above those given in the Characteristics sections of this document is not implied. Exposure to limiting values for extended periods may affect device reliability.

Terms and conditions of sale — NXP Semiconductors products are sold subject to the general terms and conditions of commercial sale, as published at <http://www.nxp.com/profile/terms>, including those pertaining to warranty, intellectual property rights infringement and limitation of liability, unless explicitly otherwise agreed to in writing by NXP Semiconductors. In case of any inconsistency or conflict between information in this document and such terms and conditions, the latter will prevail.

No offer to sell or license — Nothing in this document may be interpreted or construed as an offer to sell products that is open for acceptance or the grant, conveyance or implication of any license under any copyrights, patents or other industrial or intellectual property rights.

Export control — This document as well as the item(s) described herein may be subject to export control regulations. Export might require a prior authorization from national authorities.

17.4 Trademarks

Notice: All referenced brands, product names, service names and trademarks are the property of their respective owners.

I²C-bus — logo is a trademark of NXP B.V.

18. Contact information

For more information, please visit: <http://www.nxp.com>

For sales office addresses, please send an email to: salesaddresses@nxp.com

19. Contents

1	General description	1	13	Handling information	31
2	Features	1	14	Soldering of SMD packages	31
3	Ordering information	2	14.1	Introduction to soldering	31
4	Marking	2	14.2	Wave and reflow soldering	31
5	Block diagram	3	14.3	Wave soldering	32
6	Pinning information	4	14.4	Reflow soldering	32
6.1	Pinning	4	15	Abbreviations	33
6.2	Pin description	5	16	Revision history	34
7	Functional description	5	17	Legal information	35
7.1	Power-on reset	6	17.1	Data sheet status	35
7.2	LCD bias generator	6	17.2	Definitions	35
7.3	LCD voltage selector	6	17.3	Disclaimers	35
7.4	LCD drive mode waveforms	9	17.4	Trademarks	35
7.4.1	Static drive mode	9	18	Contact information	35
7.4.2	1:2 Multiplex drive mode	10	19	Contents	36
7.4.3	1:3 Multiplex drive mode	12			
7.4.4	1:4 Multiplex drive mode	13			
7.5	Oscillator	14			
7.5.1	Internal clock	14			
7.5.2	External clock	14			
7.6	Timing	14			
7.7	Display register	14			
7.8	Segment outputs	14			
7.9	Backplane outputs	14			
7.10	Display RAM	15			
7.11	Data pointer	17			
7.12	Subaddress counter	17			
7.13	Output bank selector	17			
7.14	Input bank selector	18			
7.15	Blinker	18			
7.16	Characteristics of the I ² C-bus	19			
7.16.1	Bit transfer	19			
7.16.2	START and STOP conditions	19			
7.16.3	System configuration	19			
7.16.4	Acknowledge	20			
7.16.5	I ² C-bus controller	20			
7.16.6	Input filters	21			
7.16.7	I ² C-bus protocol	21			
7.17	Command decoder	22			
7.18	Display controller	24			
7.19	Multiple chip operation	24			
8	Internal circuitry	25			
9	Limiting values	26			
10	Static characteristics	27			
11	Dynamic characteristics	28			
12	Package outline	30			

Please be aware that important notices concerning this document and the product(s) described herein, have been included in section 'Legal information'.

founded by

PHILIPS

© NXP B.V. 2009.

All rights reserved.

For more information, please visit: <http://www.nxp.com>

For sales office addresses, please send an email to: salesaddresses@nxp.com

Date of release: 18 March 2009

Document identifier: PCF8562_4