

## NXP ultra-low-power RTC/calendars PCF8523 & PCF2123

# Save power with small, ultra-efficient RTCs

Designed to perform critical time-keeping functions in a range of applications, these small, highly efficient RTC/calendars fit nearly anywhere and cut power demands by as much as 60 percent.

### Key features

- ▶ 32.768 kHz quartz crystal
- ▶ Resolution: seconds to years
- ▶ Freely programmable timer and alarm function with interrupt
- ▶ Low backup current: 100 nA typ at  $V_{DD} = 2.0$  V and  $T_{amb} = 25$  °C
- ▶ Internal Power-On Reset
- ▶ Open drain interrupt and clock output pins
- ▶ Programmable offset register for frequency adjustment
- ▶ Watchdog timer

### Ultra-low-power I<sup>2</sup>C RTC/calendar PCF8523

- ▶ Clock operating voltage: 1.2 V to 5.5 V
- ▶ 2 line bi-directional 1 MHz Fast-mode Plus I<sup>2</sup>C interface
- ▶ Battery backup input pin and switch-over circuitry
- ▶ Integrated oscillator load capacitors for  $C_L = 7$  and 12.5 pF
- ▶ Second countdown timer with interrupt output

### Ultra-low-power SPI RTC/calendar PCF2123

- ▶ Clock operating voltage: 1.1 to 5.5 V
- ▶ 3-line SPI with separate, combinable data I/O
- ▶ Serial interface (at  $V_{DD} = 1.6$  to 5.5 V)
- ▶ Free programmable timer and alarm with interrupt capability
- ▶ Integrated oscillator load capacitors for  $C_L = 7$  pF

### Key applications

- ▶ Time-keeping functions
- ▶ Battery-powered devices
- ▶ Metering
- ▶ High-duration timers
- ▶ Daily alarms
- ▶ Systems with low standby power

The NXP PCF8523 and PCF2123 are CMOS devices that combine a real-time clock (RTC) and a calendar. Optimized for low power consumption, they operate at a current of less than 100 nA with a 2.0 V power supply, and consume less than 0.2  $\mu$ W of power. The PCF8523 uses an I<sup>2</sup>C-bus serial interface while the PCF2123 is equipped with an SPI serial interface.

Both devices are cased in tiny leadless packages that save space in compact designs. This makes them well suited for handheld and battery-operated applications, including blood-pressure monitors and other home-use medical devices, pocket calculators, portable phones, and PDAs. They are also an excellent choice for white goods, such as washing machines, metering units, and other industrial systems. Both devices can be powered by a very small battery cell or a super-cap.



The calendar functions track year, month, weekday, and day with built-in Leap Year correction. The programmable alarm and timer function gives the option of generating a wake-up signal on an interrupt pin.

In the PCF2123, the Watchdog timer can be used to wake a microcontroller from hibernation mode or monitor microcontroller tasks independently.

### PCF8523 block diagram

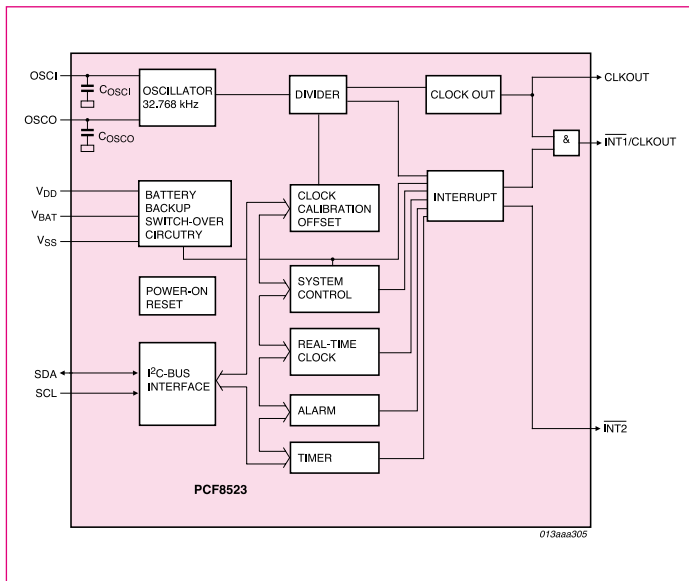

### PCF2123 block diagram

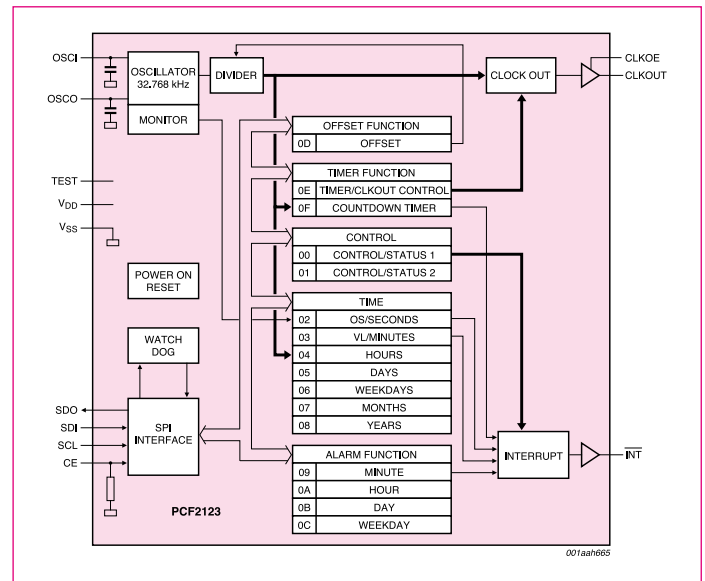

### Selection guide

Characteristics	PCF8523	PCF2123	PCF85(1)63	PCA21125	PCA8565
Interface	I <sup>2</sup> C	SPI	I <sup>2</sup> C	SPI	I <sup>2</sup> C
Temperature range	-40° to +85 °C	-40° to +85 °C	-40 to +85 °C	-40 to +125 °C	-40 to +125 °C
Supply voltage V <sub>DD</sub> clock	1.2 to 5.5 V	1.1 V to 5.5 V	1.0 to 5.5 V	1.3 to 5.5 V	1.0 to 5.5 V
Supply voltage V <sub>DD</sub> interface	1.6 to 5.5 V	1.6 V to 5.5 V	1.8 to 5.5 V	1.6 to 5.5 V	1.8 to 5.5 V
Supply current at V <sub>DD</sub> = 2 V	100 nA	100 nA	270 nA	640 nA	600 nA
Electronic tuning	yes	yes	no	no	no

### Ordering Information

Type	Package tape and reel	Type	Version
PCF8523T/1	SO8, plastic small outline package; 8 leads; body width 3.9 mm	SOT96-1	1
PCF8523TS/1	TSSOP14, plastic thin shrink small outline package; 14 leads; body width 4.4 mm	SOT402-1	1
PCF8523TK/1	HVSON8, plastic thermal enhanced very thin small outline package; no leads; 8 terminals; 4 x 4 x 0.85 mm	SOT909-1	1
PCF2123TS/1	TSSOP14, plastic thin shrink small outline package, 14 leads; body width 4.4 mm	SOT402-1	1
PCF2123BS/1	HVQFN16, plastic thermal enhanced very thin quad flat package; no leads; 16 terminals; body 3 x 3 x 0.85 mm	SOT758-1	1
PCF2123U/10AA/1	Bare die, die thickness 200 μm	-	1
PCF2123U/12AA/1	Bare die with gold bumps, die thickness 200 μm	-	1
PCF2123U/12HA/1	Bare die with gold bumps, die thickness 150 μm	-	1
PCF8523U/12AA/1	Bare die with gold bumps, die thickness 200 μm	-	1

[www.nxp.com](http://www.nxp.com)

© 2011 NXP Semiconductors N.V.

All rights reserved. Reproduction in whole or in part is prohibited without the prior written consent of the copyright owner. The information presented in this document does not form part of any quotation or contract, is believed to be accurate and reliable and may be changed without notice. No liability will be accepted by the publisher for any consequence of its use. Publication thereof does not convey nor imply any license under patent- or other industrial or intellectual property rights.

Date of release: March 2011

Document order number: 9397 750 17076

Printed in the Netherlands