



# PCA9956B

## 24-channel Fm+ I<sup>2</sup>C-bus 57 mA/20 V constant current LED driver

Rev. 1.2 — 10 June 2020

Product data sheet

### 1. General description

The PCA9956B is an I<sup>2</sup>C-bus controlled 24-channel constant current LED driver optimized for dimming and blinking 57 mA Red/Green/Blue/Amber (RGBA) LEDs in amusement products. Each LED output has its own 8-bit resolution (256 steps) fixed frequency individual PWM controller that operates at 31.25 kHz with a duty cycle that is adjustable from 0 % to 99.6 % to allow the LED to be set to a specific brightness value. An additional 8-bit resolution (256 steps) group PWM controller has both a fixed frequency of 122 Hz and an adjustable frequency between 15 Hz to once every 16.8 seconds with a duty cycle that is adjustable from 0 % to 99.6 % that is used to either dim or blink all LEDs with the same value.

Each LED output can be off, on (no PWM control), set at its individual PWM controller value or at both individual and group PWM controller values. The PCA9956B operates with a supply voltage range of 3 V to 5.5 V and the constant current sink LED outputs allow up to 20 V for the LED supply. The output peak current is adjustable with an 8-bit linear DAC from 225  $\mu$ A to 57 mA.

This device has built-in open, short load and overtemperature detection circuitry. The error information from the corresponding register can be read via the I<sup>2</sup>C-bus. Additionally, a thermal shutdown feature protects the device when internal junction temperature exceeds the limit allowed for the process.

The PCA9956B device has a Fast-mode Plus (Fm+) I<sup>2</sup>C-bus interface. Fm+ devices offer higher frequency (up to 1 MHz) or more densely populated bus operation (up to 4000 pF).

The active LOW output enable input pin ( $\overline{\text{OE}}$ ) blinks all the LED outputs and can be used to externally PWM the outputs, which is useful when multiple devices need to be dimmed or blinked together without using software control.

Software programmable LED Group and three Sub Call I<sup>2</sup>C-bus addresses allow all or defined groups of PCA9956B devices to respond to a common I<sup>2</sup>C-bus address, allowing for example, all red LEDs to be turned on or off at the same time or marquee chasing effect, thus minimizing I<sup>2</sup>C-bus commands. On power-up, PCA9956B will have a unique Sub Call address to identify it as a 24-channel LED driver. This allows mixing of devices with different channel widths. Three hardware address pins on PCA9956B allow up to 125 devices on the same bus.

The Software Reset (SWRST) function allows the master to perform a reset of the PCA9956B through the I<sup>2</sup>C-bus, identical to the Power-On Reset (POR) that initializes the registers to their default state causing the output current switches to be OFF (LED off). This allows an easy and quick way to reconfigure all device registers to the same condition.



## 2. Features and benefits

- 24 LED drivers. Each output programmable at:
  - ◆ Off
  - ◆ On
  - ◆ Programmable LED brightness
  - ◆ Programmable group dimming/blinking mixed with individual LED brightness
  - ◆ Programmable LED output delay to reduce EMI and surge currents
- 24 constant current output channels can sink up to 57 mA, tolerate up to 20 V when OFF
- Output current adjusted through an external resistor ( $R_{\text{ext}}$  input)
- Output current accuracy
  - ◆  $\pm 4$  % between output channels
  - ◆  $\pm 6$  % between PCA9956B devices
- Open/short load/overtemperature detection mode to detect individual LED errors ( $R_{\text{ext}} < 3 \text{ k}\Omega$ )
- 1 MHz Fast-mode Plus compatible I<sup>2</sup>C-bus interface with 30 mA high drive capability on SDA output for driving high capacitive buses
- 256-step (8-bit) linear programmable brightness per LED output varying from fully off (default) to maximum brightness using a 31.25 kHz PWM signal
- 256-step group brightness control allows general dimming (using a 122 Hz PWM signal) from fully off to maximum brightness (default)
- 256-step group blinking with frequency programmable from 15 Hz to 16.8 s and duty cycle from 0 % to 99.6 %
- Output state change programmable on the Acknowledge or the STOP Command to update outputs byte-by-byte or all at the same time (default to 'Change on STOP').
- Active LOW Output Enable ( $\overline{\text{OE}}$ ) input pin allows for hardware blinking and dimming of the LEDs
- Three quinary hardware address pins allow 125 PCA9956B devices to be connected to the same I<sup>2</sup>C-bus and to be individually programmed
- Four software programmable I<sup>2</sup>C-bus addresses (one LED Group Call address and three LED Sub Call addresses) allow groups of devices to be addressed at the same time in any combination (for example, one register used for 'All Call' so that all the PCA9956Bs on the I<sup>2</sup>C-bus can be addressed at the same time and the second register used for three different addresses so that  $\frac{1}{3}$  of all devices on the bus can be addressed at the same time in a group). Software enable and disable for each programmable I<sup>2</sup>C-bus address.
- Unique power-up default Sub Call address allows mixing of devices with different channel widths
- Software Reset feature (SWRST Call) allows the device to be reset through the I<sup>2</sup>C-bus
- 8 MHz internal oscillator requires no external components
- Internal power-on reset
- Noise filter on SDA/SCL inputs
- No glitch on LEDn outputs on power-up
- Low standby current
- Operating power supply voltage ( $V_{\text{DD}}$ ) range of 3 V to 5.5 V

- 5.5 V tolerant inputs on non-LED pins
- -40 °C to +85 °C operation
- ESD protection exceeds 3000 V HBM per JESD22-A114
- Latch-up testing is done to JEDEC Standard JESD78 which exceeds 100 mA
- Packages offered: HTSSOP38

### 3. Applications

- Amusement products
- RGB or RGBA LED drivers
- LED status information
- LED displays
- LCD backlights
- Keypad backlights for cellular phones or handheld devices

### 4. Ordering information

Table 1. Ordering information

Type number	Topside mark	Package		
		Name	Description	Version
PCA9956BTW	PCA9956BTW	HTSSOP38	plastic thermal enhanced thin shrink small outline package; 38 leads; body width 4.4 mm; lead pitch 0.5 mm; exposed die pad	SOT1331-1

#### 4.1 Ordering options

Table 2. Ordering options

Type number	Orderable part number	Package	Packing method	Minimum order quantity	Temperature
PCA9956BTW	PCA9956BTWY	HTSSOP38	Reel 13" Q1/T1 *Standard mark SMD dry pack	2500	T <sub>amb</sub> = -40 °C to +85 °C

5. Block diagram

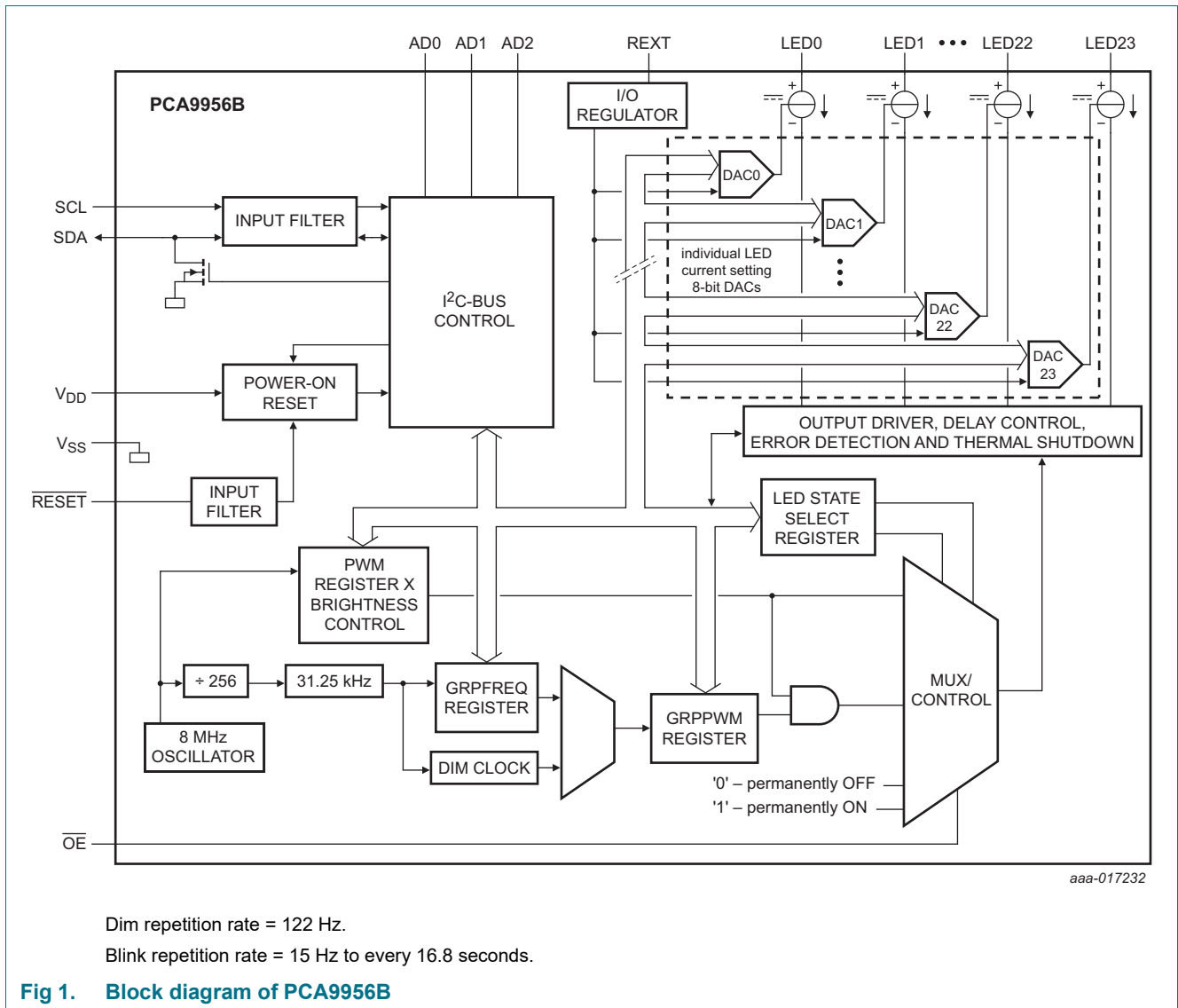

Dim repetition rate = 122 Hz.  
 Blink repetition rate = 15 Hz to every 16.8 seconds.

Fig 1. Block diagram of PCA9956B

## 6. Pinning information

### 6.1 Pinning

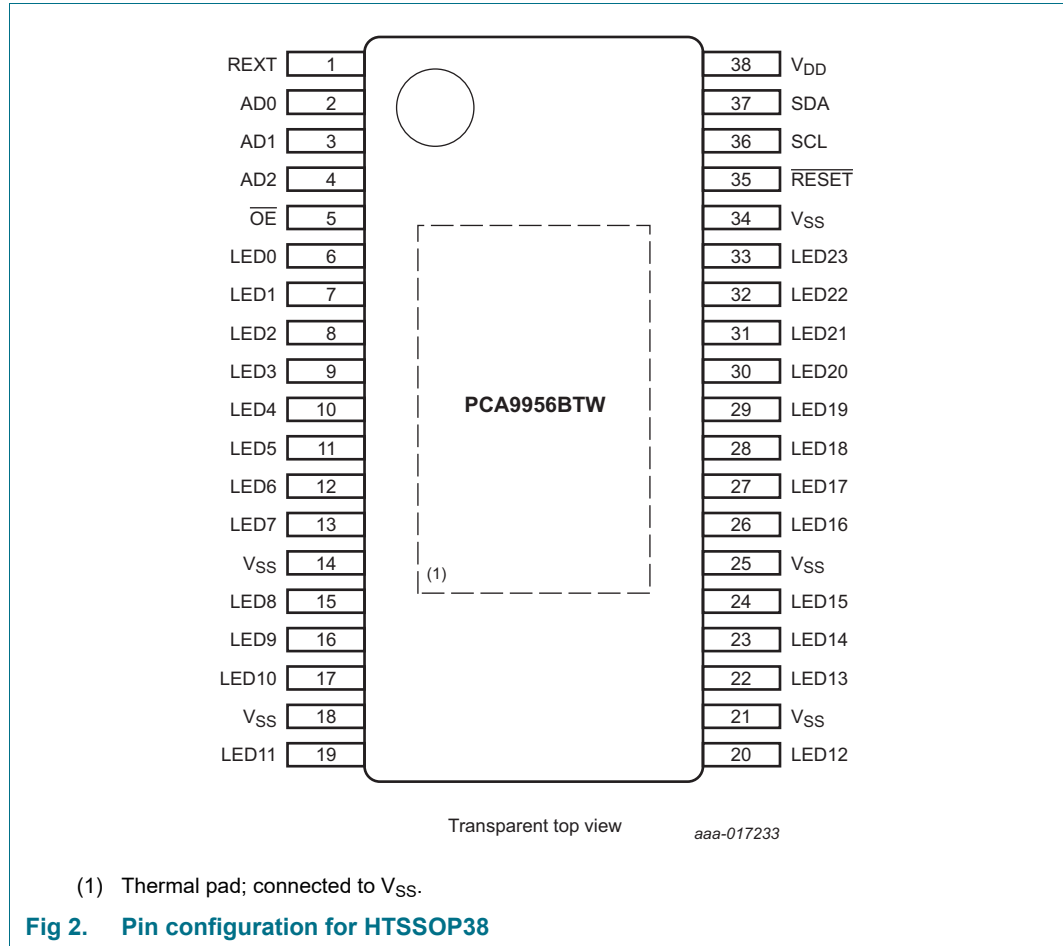

## 6.2 Pin description

Table 3. Pin description

Symbol	Pin	Type	Description
REXT	1	I	current set resistor input; resistor to ground
AD0	2	I	address input 0
AD1	3	I	address input 1
AD2	4	I	address input 2
$\overline{OE}$	5	I	active LOW output enable for LEDs
LED0	6	O	LED driver 0
LED1	7	O	LED driver 1
LED2	8	O	LED driver 2
LED3	9	O	LED driver 3
LED4	10	O	LED driver 4
LED5	11	O	LED driver 5
LED6	12	O	LED driver 6
LED7	13	O	LED driver 7
LED8	15	O	LED driver 8
LED9	16	O	LED driver 9
LED10	17	O	LED driver 10
LED11	19	O	LED driver 11
LED12	20	O	LED driver 12
LED13	22	O	LED driver 13
LED14	23	O	LED driver 14
LED15	24	O	LED driver 15
LED16	26	O	LED driver 16
LED17	27	O	LED driver 17
LED18	28	O	LED driver 18
LED19	29	O	LED driver 19
LED20	30	O	LED driver 20
LED21	31	O	LED driver 21
LED22	32	O	LED driver 22
LED23	33	O	LED driver 23
$\overline{RESET}$	35	I	active LOW reset input with external 10 k $\Omega$ pull-up resistor
SCL	36	I	serial clock line
SDA	37	I/O	serial data line
V <sub>SS</sub>	14, 18, 21, 25, 34 <a href="#">[1]</a>	ground	supply ground
V <sub>DD</sub>	38	power supply	supply voltage

[1] HTSSOP38 package supply ground is connected to both V<sub>SS</sub> pins and exposed center pad. V<sub>SS</sub> pins must be connected to supply ground for proper device operation. For enhanced thermal, electrical, and board level performance, the exposed pad needs to be soldered to the board using a corresponding thermal pad on the board and for proper heat conduction through the board, thermal vias need to be incorporated in the printed-circuit board in the thermal pad region.

## 7. Functional description

Refer to [Figure 1 “Block diagram of PCA9956B”](#).

### 7.1 Device addresses

Following a START condition, the bus master must output the address of the slave it is accessing.

For PCA9956B there are a maximum of 125 possible programmable addresses using the three quinary hardware address pins.

#### 7.1.1 Regular I<sup>2</sup>C-bus slave address

The I<sup>2</sup>C-bus slave address of the PCA9956B is shown in [Figure 3](#). The 7-bit slave address is determined by the quinary input pads AD0, AD1 and AD2. Each pad can have one of five states (GND, pull-up, floating, pull-down, and V<sub>DD</sub>) based on how the input pad is connected on the board. At power-up or hardware/software reset, the quinary input pads are sampled and set the slave address of the device internally. To conserve power, once the slave address is determined, the quinary input pads are turned off and will not be sampled until the next time the device is power cycled. [Table 4](#) lists the five possible connections for the quinary input pads along with the external resistor values that must be used.

**Table 4. Quinary input pad connection**

Pad connection (pins AD2, AD1, AD0) <sup>[1]</sup>	Mnemonic	External resistor (kΩ)	
		Min.	Max.
tie to ground	GND	0	17.9
resistor pull-down to ground	PD	34.8	270
open (floating)	FLT	503	∞
resistor pull-up to V <sub>DD</sub>	PU	31.7	340
tie to V <sub>DD</sub>	V <sub>DD</sub>	0	22.1

[1] These AD[2:0] inputs must be stable before the supply V<sub>DD</sub> to the chip.

[Table 5](#) lists all 125 possible slave addresses of the device based on all combinations of the five states connected to three address input pins AD0, AD1 and AD2.

**Table 5. I<sup>2</sup>C-bus slave address**

Hardware selectable input pins			I <sup>2</sup> C-bus slave address for PCA9956B			
AD2	AD1	AD0	Decimal	Hex	Binary (A[6:0])	Address (R/W = 0)
GND	GND	GND	1	01	0000001 <sup>[1]</sup>	02h
GND	GND	PD	2	02	0000010 <sup>[1]</sup>	04h
GND	GND	FLT	3	03	0000011 <sup>[1]</sup>	06h
GND	GND	PU	4	04	0000100 <sup>[1]</sup>	08h
GND	GND	V <sub>DD</sub>	5	05	0000101 <sup>[1]</sup>	0Ah
GND	PD	GND	6	06	0000110 <sup>[1]</sup>	0Ch
GND	PD	PD	7	07	0000111 <sup>[1]</sup>	0Eh
GND	PD	FLT	8	08	0001000	10h
GND	PD	PU	9	09	0001001	12h

Table 5. I<sup>2</sup>C-bus slave address ...continued

Hardware selectable input pins			I <sup>2</sup> C-bus slave address for PCA9956B			
AD2	AD1	AD0	Decimal	Hex	Binary (A[6:0])	Address (R/W = 0)
GND	PD	V <sub>DD</sub>	10	0A	0001010	14h
GND	FLT	GND	11	0B	0001011	16h
GND	FLT	PD	12	0C	0001100	18h
GND	FLT	FLT	13	0D	0001101	1Ah
GND	FLT	PU	14	0E	0001110	1Ch
GND	FLT	V <sub>DD</sub>	15	0F	0001111	1Eh
GND	PU	GND	16	10	0010000	20h
GND	PU	PD	17	11	0010001	22h
GND	PU	FLT	18	12	0010010	24h
GND	PU	PU	19	13	0010011	26h
GND	PU	V <sub>DD</sub>	20	14	0010100	28h
GND	V <sub>DD</sub>	GND	21	15	0010101	2Ah
GND	V <sub>DD</sub>	PD	22	16	0010110	2Ch
GND	V <sub>DD</sub>	FLT	23	17	0010111	2Eh
GND	V <sub>DD</sub>	PU	24	18	0011000	30h
GND	V <sub>DD</sub>	V <sub>DD</sub>	25	19	0011001	32h
PD	GND	GND	26	1A	0011010	34h
PD	GND	PD	27	1B	0011011	36h
PD	GND	FLT	28	1C	0011100	38h
PD	GND	PU	29	1D	0011101	3Ah
PD	GND	V <sub>DD</sub>	30	1E	0011110	3Ch
PD	PD	GND	31	1F	0011111	3Eh
PD	PD	PD	32	20	0100000	40h
PD	PD	FLT	33	21	0100001	42h
PD	PD	PU	34	22	0100010	44h
PD	PD	V <sub>DD</sub>	35	23	0100011	46h
PD	FLT	GND	36	24	0100100	48h
PD	FLT	PD	37	25	0100101	4Ah
PD	FLT	FLT	38	26	0100110	4Ch
PD	FLT	PU	39	27	0100111	4Eh
PD	FLT	V <sub>DD</sub>	40	28	0101000	50h
PD	PU	GND	41	29	0101001	52h
PD	PU	PD	42	2A	0101010	54h
PD	PU	FLT	43	2B	0101011	56h
PD	PU	PU	44	2C	0101100	58h
PD	PU	V <sub>DD</sub>	45	2D	0101101	5Ah
PD	V <sub>DD</sub>	GND	46	2E	0101110	5Ch
PD	V <sub>DD</sub>	PD	47	2F	0101111	5Eh
PD	V <sub>DD</sub>	FLT	48	30	0110000	60h
PD	V <sub>DD</sub>	PU	49	31	0110001	62h



Table 5. I<sup>2</sup>C-bus slave address ...continued

Hardware selectable input pins			I <sup>2</sup> C-bus slave address for PCA9956B			
AD2	AD1	AD0	Decimal	Hex	Binary (A[6:0])	Address (R/W = 0)
PD	V <sub>DD</sub>	V <sub>DD</sub>	50	32	0110010	64h
FLT	GND	GND	51	33	0110011	66h
FLT	GND	PD	52	34	0110100	68h
FLT	GND	FLT	53	35	0110101	6Ah
FLT	GND	PU	54	36	0110110	6Ch
FLT	GND	V <sub>DD</sub>	55	37	0110111	6Eh
FLT	PD	GND	56	38	0111000	70h
FLT	PD	PD	57	39	0111001	72h
FLT	PD	FLT	58	3A	0111010	74h
FLT	PD	PU	59	3B	0111011	76h
FLT	PD	V <sub>DD</sub>	60	3C	0111100	78h
FLT	FLT	GND	61	3D	0111101	7Ah
FLT	FLT	PD	62	3E	0111110	7Ch
FLT	FLT	FLT	63	3F	0111111	7Eh
FLT	FLT	PU	64	40	1000000	80h
FLT	FLT	V <sub>DD</sub>	65	41	1000001	82h
FLT	PU	GND	66	42	1000010	84h
FLT	PU	PD	67	43	1000011	86h
FLT	PU	FLT	68	44	1000100	88h
FLT	PU	PU	69	45	1000101	8Ah
FLT	PU	V <sub>DD</sub>	70	46	1000110	8Ch
FLT	V <sub>DD</sub>	GND	71	47	1000111	8Eh
FLT	V <sub>DD</sub>	PD	72	48	1001000	90h
FLT	V <sub>DD</sub>	FLT	73	49	1001001	92h
FLT	V <sub>DD</sub>	PU	74	4A	1001010	94h
FLT	V <sub>DD</sub>	V <sub>DD</sub>	75	4B	1001011	96h
PU	GND	GND	76	4C	1001100	98h
PU	GND	PD	77	4D	1001101	9Ah
PU	GND	FLT	78	4E	1001110	9Ch
PU	GND	PU	79	4F	1001111	9Eh
PU	GND	V <sub>DD</sub>	80	50	1010000	A0h
PU	PD	GND	81	51	1010001	A2h
PU	PD	PD	82	52	1010010	A4h
PU	PD	FLT	83	53	1010011	A6h
PU	PD	PU	84	54	1010100	A8h
PU	PD	V <sub>DD</sub>	85	55	1010101	AAh
PU	FLT	GND	86	56	1010110	ACh
PU	FLT	PD	87	57	1010111	A Eh
PU	FLT	FLT	88	58	1011000	B0h
PU	FLT	PU	89	59	1011001	B2h

Table 5. I<sup>2</sup>C-bus slave address ...continued

Hardware selectable input pins			I <sup>2</sup> C-bus slave address for PCA9956B			
AD2	AD1	AD0	Decimal	Hex	Binary (A[6:0])	Address (R/W = 0)
PU	FLT	V <sub>DD</sub>	90	5A	1011010	B4h
PU	PU	GND	91	5B	1011011	B6h
PU	PU	PD	92	5C	1011100	B8h
PU	PU	FLT	93	5D	1011101	BAh
PU	PU	PU	94	5E	1011110	BCh
PU	PU	V <sub>DD</sub>	95	5F	1011111	BEh
PU	V <sub>DD</sub>	GND	96	60	1100000	C0h
PU	V <sub>DD</sub>	PD	97	61	1100001	C2h
PU	V <sub>DD</sub>	FLT	98	62	1100010	C4h
PU	V <sub>DD</sub>	PU	99	63	1100011	C6h
PU	V <sub>DD</sub>	V <sub>DD</sub>	100	64	1100100	C8h
V <sub>DD</sub>	GND	GND	101	65	1100101	CAh
V <sub>DD</sub>	GND	PD	102	66	1100110	CCh
V <sub>DD</sub>	GND	FLT	103	67	1100111	CEh
V <sub>DD</sub>	GND	PU	104	68	1101000	D0h
V <sub>DD</sub>	GND	V <sub>DD</sub>	105	69	1101001	D2h
V <sub>DD</sub>	PD	GND	106	6A	1101010	D4h
V <sub>DD</sub>	PD	PD	107	6B	1101011	D6h
V <sub>DD</sub>	PD	FLT	108	6C	1101100	D8h
V <sub>DD</sub>	PD	PU	109	6D	1101101	DAh
V <sub>DD</sub>	PD	V <sub>DD</sub>	110	6E	1101110	DCh
V <sub>DD</sub>	FLT	GND	111	6F	1101111	DEh
V <sub>DD</sub>	FLT	PD	112	70	1110000	E0h
V <sub>DD</sub>	FLT	FLT	113	71	1110001	E2h
V <sub>DD</sub>	FLT	PU	114	72	1110010	E4h
V <sub>DD</sub>	FLT	V <sub>DD</sub>	115	73	1110011	E6h
V <sub>DD</sub>	PU	GND	116	74	1110100	E8h
V <sub>DD</sub>	PU	PD	117	75	1110101	EAh
V <sub>DD</sub>	PU	FLT	118	76	1110110	ECh
V <sub>DD</sub>	PU	PU	119	77	1110111	EEh
V <sub>DD</sub>	PU	V <sub>DD</sub>	120	78	1111000 <sup>[1]</sup>	F0h
V <sub>DD</sub>	V <sub>DD</sub>	GND	121	79	1111001 <sup>[1]</sup>	F2h
V <sub>DD</sub>	V <sub>DD</sub>	PD	122	7A	1111010 <sup>[1]</sup>	F4h
V <sub>DD</sub>	V <sub>DD</sub>	FLT	123	7B	1111011 <sup>[1]</sup>	F6h
V <sub>DD</sub>	V <sub>DD</sub>	PU	124	7C	1111100 <sup>[1]</sup>	F8h
V <sub>DD</sub>	V <sub>DD</sub>	V <sub>DD</sub>	125	7D	1111101 <sup>[1]</sup>	FAh

[1] See 'Remark' below.

**Remark:** Reserved I<sup>2</sup>C-bus addresses must be used with caution since they can interfere with:

- ‘reserved for future use’ I<sup>2</sup>C-bus addresses (0000 011, 1111 1XX)
- slave devices that use the 10-bit addressing scheme (1111 0XX)
- slave devices that are designed to respond to the General Call address (0000 000)
- High-speed mode (Hs-mode) master code (0000 1XX)

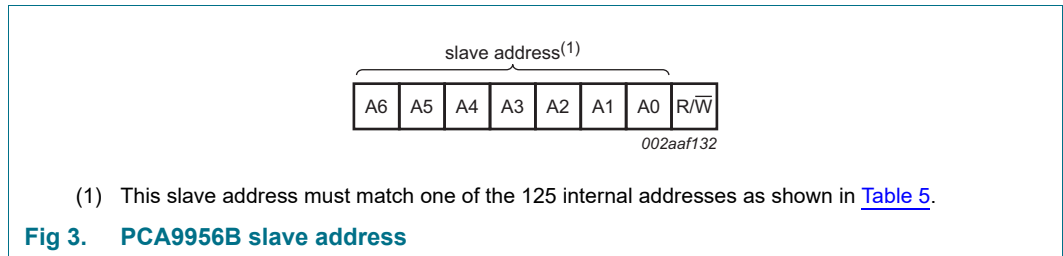

The last bit of the address byte defines the operation to be performed. When set to logic 1 a read is selected, while a logic 0 selects a write operation.

### 7.1.2 LED All Call I<sup>2</sup>C-bus address

- Default power-up value (ALLCALLADR register): E0h or 1110 000X
- Programmable through I<sup>2</sup>C-bus (volatile programming)
- At power-up, LED All Call I<sup>2</sup>C-bus address is enabled. PCA9956B sends an ACK when E0h (R/W = 0) or E1h (R/W = 1) is sent by the master.

See [Section 7.3.10 “ALLCALLADR, LED All Call I<sup>2</sup>C-bus address”](#) for more detail.

**Remark:** The default LED All Call I<sup>2</sup>C-bus address (E0h or 1110 000X) must not be used as a regular I<sup>2</sup>C-bus slave address since this address is enabled at power-up. All of the PCA9956Bs on the I<sup>2</sup>C-bus will acknowledge the address if sent by the I<sup>2</sup>C-bus master.

### 7.1.3 LED Sub Call I<sup>2</sup>C-bus addresses

- Three different I<sup>2</sup>C-bus addresses can be used
- Default power-up values:
  - SUBADR1 register: EEh or 1110 111X
  - SUBADR2 register: EEh or 1110 111X
  - SUBADR3 register: EEh or 1110 111X
- Programmable through I<sup>2</sup>C-bus (volatile programming)
- At power-up, SUBADR1 is enabled while SUBADR2 and SUBADR3 I<sup>2</sup>C-bus addresses are disabled.

**Remark:** At power-up SUBADR1 identifies this device as a 24-channel driver.

See [Section 7.3.9 “LED Sub Call I<sup>2</sup>C-bus addresses for PCA9956B”](#) for more detail.

**Remark:** The default LED Sub Call I<sup>2</sup>C-bus addresses may be used as regular I<sup>2</sup>C-bus slave addresses as long as they are disabled.

## 7.2 Control register

Following the successful acknowledgement of the slave address, LED All Call address or LED Sub Call address, the bus master will send a byte to the PCA9956B, which will be stored in the Control register.

The lowest 7 bits are used as a pointer to determine which register will be accessed (D[6:0]). The highest bit is used as Auto-Increment Flag (AIF).

This bit along with the MODE1 register bit 5 and bit 6 provide the Auto-Increment feature.

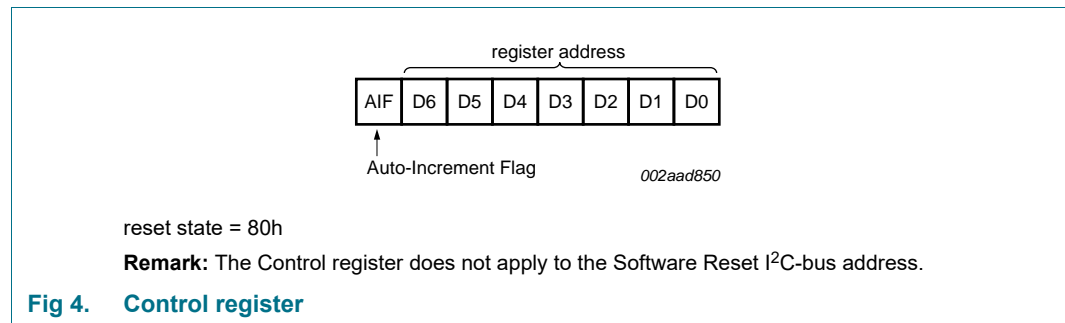

When the Auto-Increment Flag is set (AIF = logic 1), the seven low order bits of the Control register are automatically incremented after a read or write. This allows the user to program the registers sequentially. Four different types of Auto-Increment are possible, depending on AI1 and AI0 values of MODE1 register.

**Table 6. Auto-Increment options**

AIF	AI1[1]	AI0[1]	Function
0	0	0	no Auto-Increment
1	0	0	Auto-Increment for registers (00h to 3Eh). D[6:0] roll over to 00h after the last register 3Eh is accessed.
1	0	1	Auto-Increment for individual brightness registers only (0Ah to 21h). D[6:0] roll over to 0Ah after the last register (21h) is accessed.
1	1	0	Auto-Increment for MODE1 to IREF23 control registers (00h to 39h). D[6:0] roll over to 00h after the last register (39h) is accessed.
1	1	1	Auto-Increment for global control registers and individual brightness registers (08h to 21h). D[6:0] roll over to 08h after the last register (21h) is accessed.

[1] AI1 and AI0 come from MODE1 register.

**Remark:** Other combinations not shown in [Table 6](#) (AIF + AI[1:0] = 001b, 010b and 011b) are reserved and must not be used for proper device operation.

AIF + AI[1:0] = 000b is used when the same register must be accessed several times during a single I<sup>2</sup>C-bus communication, for example, changes the brightness of a single LED. Data is overwritten each time the register is accessed during a write operation.

AIF + AI[1:0] = 100b is used when all the registers must be sequentially accessed, for example, power-up programming.

AIF + AI[1:0] = 101b is used when the 24 LED drivers must be individually programmed with different values during the same I<sup>2</sup>C-bus communication, for example, changing color setting to another color setting.

AIF + AI[1:0] = 110b is used when MODE1 to IREF23 registers must be programmed with different settings during the same I<sup>2</sup>C-bus communication.

AIF + AI[1:0] = 111b is used when the 24 LED drivers must be individually programmed with different values in addition to global programming.

Only the 7 least significant bits D[6:0] are affected by the AIF, AI1 and AI0 bits.

When the Control register is written, the register entry point determined by D[6:0] is the first register that will be addressed (read or write operation), and can be anywhere between 00h and 3Eh (as defined in Table 7). When AIF = 1, the Auto-Increment Flag is set and the rollover value at which the register increment stops and goes to the next one is determined by AIF, AI1 and AI0. See Table 6 for rollover values. For example, if MODE1 register bit AI1 = 0 and AI0 = 1 and if the Control register = 1001 0000, then the register addressing sequence will be (in hexadecimal):

10 → 11 → ... → 21 → 0A → 0B → ... → 21 → 0A → 0B → ... as long as the master keeps sending or reading data.

If MODE1 register bit AI1 = 0 and AI0 = 0 and if the Control register = 1010 0010, then the register addressing sequence will be (in hexadecimal):

22 → 23 → ... → 3E → 00 → 01 → ... → 21 → 0A → 0B → ... as long as the master keeps sending or reading data.

If MODE1 register bit AI1 = 0 and AI0 = 1 and if the Control register = 1000 0101, then the register addressing sequence will be (in hexadecimal):

05 → 06 → ... → 21 → 0A → 0B → ... → 21 → 0A → 0B → ... as long as the master keeps sending or reading data.

**Remark:** Writing to registers marked 'not used' will return NACK.

### 7.3 Register definitions

Table 7. Register summary

Register number (hex)	D6	D5	D4	D3	D2	D1	D0	Name	Type	Function
00h	0	0	0	0	0	0	0	MODE1	read/write	Mode register 1
01h	0	0	0	0	0	0	1	MODE2	read/write	Mode register 2
02h	0	0	0	0	0	1	0	LEDOUT0	read/write	LED output state 0
03h	0	0	0	0	0	1	1	LEDOUT1	read/write	LED output state 1
04h	0	0	0	0	1	0	0	LEDOUT2	read/write	LED output state 2
05h	0	0	0	0	1	0	1	LEDOUT3	read/write	LED output state 3
06h	0	0	0	0	1	1	0	LEDOUT4	read/write	LED output state 4
07h	0	0	0	0	1	1	1	LEDOUT5	read/write	LED output state 5
08h	0	0	0	1	0	0	0	GRPPWM	read/write	group duty cycle control
09h	0	0	0	1	0	0	1	GRPFREQ	read/write	group frequency
0Ah	0	0	0	1	0	1	0	PWM0	read/write	brightness control LED0
0Bh	0	0	0	1	0	1	1	PWM1	read/write	brightness control LED1
0Ch	0	0	0	1	1	0	0	PWM2	read/write	brightness control LED2
0Dh	0	0	0	1	1	0	1	PWM3	read/write	brightness control LED3
0Eh	0	0	0	1	1	1	0	PWM4	read/write	brightness control LED4

Table 7. Register summary ...continued

Register number (hex)	D6	D5	D4	D3	D2	D1	D0	Name	Type	Function
0Fh	0	0	0	1	1	1	1	PWM5	read/write	brightness control LED5
10h	0	0	1	0	0	0	0	PWM6	read/write	brightness control LED6
11h	0	0	1	0	0	0	1	PWM7	read/write	brightness control LED7
12h	0	0	1	0	0	1	0	PWM8	read/write	brightness control LED8
13h	0	0	1	0	0	1	1	PWM9	read/write	brightness control LED9
14h	0	0	1	0	1	0	0	PWM10	read/write	brightness control LED10
15h	0	0	1	0	1	0	1	PWM11	read/write	brightness control LED11
16h	0	0	1	0	1	1	0	PWM12	read/write	brightness control LED12
17h	0	0	1	0	1	1	1	PWM13	read/write	brightness control LED13
18h	0	0	1	1	0	0	0	PWM14	read/write	brightness control LED14
19h	0	0	1	1	0	0	1	PWM15	read/write	brightness control LED15
1Ah	0	0	1	1	0	1	0	PWM16	read/write	brightness control LED16
1Bh	0	0	1	1	0	1	1	PWM17	read/write	brightness control LED17
1Ch	0	0	1	1	1	0	0	PWM18	read/write	brightness control LED18
1Dh	0	0	1	1	1	0	1	PWM19	read/write	brightness control LED19
1Eh	0	0	1	1	1	1	0	PWM20	read/write	brightness control LED20
1Fh	0	0	1	1	1	1	1	PWM21	read/write	brightness control LED21
20h	0	1	1	0	0	0	0	PWM22	read/write	brightness control LED22
21h	0	1	1	0	0	0	1	PWM23	read/write	brightness control LED23
22h	0	1	0	0	0	1	0	IREF0	read/write	output gain control register 0
23h	0	1	0	0	0	1	1	IREF1	read/write	output gain control register 1
24h	0	1	0	0	1	0	0	IREF2	read/write	output gain control register 2
25h	0	1	0	0	1	0	1	IREF3	read/write	output gain control register 3
26h	0	1	0	0	1	1	0	IREF4	read/write	output gain control register 4
27h	0	1	0	0	1	1	1	IREF5	read/write	output gain control register 5
28h	0	1	0	1	0	0	0	IREF6	read/write	output gain control register 6
29h	0	1	0	1	0	0	1	IREF7	read/write	output gain control register 7
2Ah	0	1	0	1	0	1	0	IREF8	read/write	output gain control register 8
2Bh	0	1	0	1	0	1	1	IREF9	read/write	output gain control register 9
2Ch	0	1	0	1	1	0	0	IREF10	read/write	output gain control register 10
2Dh	0	1	0	1	1	0	1	IREF11	read/write	output gain control register 11
2Eh	0	1	0	1	1	1	0	IREF12	read/write	output gain control register 12
2Fh	0	1	0	1	1	1	1	IREF13	read/write	output gain control register 13
30h	0	1	1	0	0	0	0	IREF14	read/write	output gain control register 14
31h	0	1	1	0	0	0	1	IREF15	read/write	output gain control register 15
32h	0	1	1	0	0	1	0	IREF16	read/write	output gain control register 16
33h	0	1	1	0	0	1	1	IREF17	read/write	output gain control register 17
34h	0	1	1	0	1	0	0	IREF18	read/write	output gain control register 18
35h	0	1	1	0	1	0	1	IREF19	read/write	output gain control register 19
36h	0	1	1	0	1	1	0	IREF20	read/write	output gain control register 20

Table 7. Register summary ...continued

Register number (hex)	D6	D5	D4	D3	D2	D1	D0	Name	Type	Function
37h	0	1	1	0	1	1	1	IREF21	read/write	output gain control register 21
38h	0	1	1	1	0	0	0	IREF22	read/write	output gain control register 22
39h	0	1	1	1	0	0	1	IREF23	read/write	output gain control register 23
3Ah	0	1	1	1	0	1	0	OFFSET	read/write	Offset/delay on LEDn outputs
3Bh	0	1	1	1	0	1	1	SUBADR1	read/write	I <sup>2</sup> C-bus subaddress 1
3Ch	0	1	1	1	1	0	0	SUBADR2	read/write	I <sup>2</sup> C-bus subaddress 2
3Dh	0	1	1	1	1	0	1	SUBADR3	read/write	I <sup>2</sup> C-bus subaddress 3
3Eh	0	1	1	1	1	1	0	ALLCALLADR	read/write	All Call I <sup>2</sup> C-bus address
3Fh	0	1	1	1	1	1	1	PWMALL	write only	brightness control for all LEDn
40h	1	0	0	0	0	0	0	IREFALL	write only	output gain control for all registers IREF0 to IREF23
41h	1	0	0	0	0	0	1	EFLAG0	read only	output error flag 0
42h	1	0	0	0	0	1	0	EFLAG1	read only	output error flag 1
43h	1	0	0	0	0	1	1	EFLAG2	read only	output error flag 2
44h	1	0	0	0	1	0	0	EFLAG3	read only	output error flag 3
45h	1	0	0	0	1	0	1	EFLAG4	read only	output error flag 4
46h	1	0	0	0	1	1	0	EFLAG5	read only	output error flag 5
47h to 7Fh								reserved	read only	not used <sup>[1]</sup>

[1] Reserved registers should not be written to and will always read back as zeros.

### 7.3.1 MODE1 — Mode register 1

**Table 8. MODE1 - Mode register 1 (address 00h) bit description**

Legend: \* default value.

Bit	Symbol	Access	Value	Description
7	AIF	read only	0	Register Auto-Increment disabled.
			1*	Register Auto-Increment enabled.
6	AI1	R/W	0*	Auto-Increment bit 1 = 0. Auto-increment range as defined in <a href="#">Table 6</a> .
			1	Auto-Increment bit 1 = 1. Auto-increment range as defined in <a href="#">Table 6</a> .
5	AI0	R/W	0*	Auto-Increment bit 0 = 0. Auto-increment range as defined in <a href="#">Table 6</a> .
			1	Auto-Increment bit 0 = 1. Auto-increment range as defined in <a href="#">Table 6</a> .
4	SLEEP	R/W	0*	Normal mode <sup>[1]</sup> .
			1	Low power mode. Oscillator off <sup>[2][3]</sup> .
3	SUB1	R/W	0	PCA9956B does not respond to I <sup>2</sup> C-bus subaddress 1.
			1*	PCA9956B responds to I <sup>2</sup> C-bus subaddress 1.
2	SUB2	R/W	0*	PCA9956B does not respond to I <sup>2</sup> C-bus subaddress 2.
			1	PCA9956B responds to I <sup>2</sup> C-bus subaddress 2.
1	SUB3	R/W	0*	PCA9956B does not respond to I <sup>2</sup> C-bus subaddress 3.
			1	PCA9956B responds to I <sup>2</sup> C-bus subaddress 3.
0	ALLCALL	R/W	0	PCA9956B does not respond to LED All Call I <sup>2</sup> C-bus address.
			1*	PCA9956B responds to LED All Call I <sup>2</sup> C-bus address.

[1] It takes 500  $\mu$ s max. for the oscillator to be up and running once SLEEP bit has been set to logic 0. Timings on LEDn outputs are not guaranteed if PWMx, GRPPWM or GRPFREQ registers are accessed within the 500  $\mu$ s window.

[2] No blinking or dimming is possible when the oscillator is off.

[3] The device must be reset if the LED driver output state is set to LDRx=11 after the device is set back to Normal mode.

### 7.3.2 MODE2 — Mode register 2

**Table 9. MODE2 - Mode register 2 (address 01h) bit description**

Legend: \* default value.

Bit	Symbol	Access	Value	Description
7	OVERTEMP	read only	0*	O.K.
			1	overtemperature condition
6	ERROR	read only	0*	no error at LED outputs
			1	any open or short-circuit detected in error flag registers (EFLAGn)
5	DMBLNK	R/W	0*	group control = dimming
			1	group control = blinking
4	CLRERR	write only	0*	self clear after write '1'
			1	Write '1' to clear all error status bits in EFLAGn register and ERROR (bit 6). The EFLAGn and ERROR bit will set to '1' if open or short-circuit is detected again.
3	OCH	R/W	0*	outputs change on STOP command
			1	outputs change on ACK



**Table 9. MODE2 - Mode register 2 (address 01h) bit description ...continued**  
 Legend: \* default value.

Bit	Symbol	Access	Value	Description
2	-	read only	1*	reserved
1	-	read only	0*	reserved
0	-	read only	1*	reserved

### 7.3.3 LEDOUT0 to LEDOUT5, LED driver output state

**Table 10. LEDOUT0 to LEDOUT5 - LED driver output state registers (address 02h to 07h) bit description**  
 Legend: \* default value.

Address	Register	Bit	Symbol	Access	Value	Description
02h	LEDOUT0	7:6	LDR3	R/W	10*	LED3 output state control
		5:4	LDR2	R/W	10*	LED2 output state control
		3:2	LDR1	R/W	10*	LED1 output state control
		1:0	LDR0	R/W	10*	LED0 output state control
03h	LEDOUT1	7:6	LDR7	R/W	10*	LED7 output state control
		5:4	LDR6	R/W	10*	LED6 output state control
		3:2	LDR5	R/W	10*	LED5 output state control
		1:0	LDR4	R/W	10*	LED4 output state control
04h	LEDOUT2	7:6	LDR11	R/W	10*	LED11 output state control
		5:4	LDR10	R/W	10*	LED10 output state control
		3:2	LDR9	R/W	10*	LED9 output state control
		1:0	LDR8	R/W	10*	LED8 output state control
05h	LEDOUT3	7:6	LDR15	R/W	10*	LED15 output state control
		5:4	LDR14	R/W	10*	LED14 output state control
		3:2	LDR13	R/W	10*	LED13 output state control
		1:0	LDR12	R/W	10*	LED12 output state control
06h	LEDOUT4	7:6	LDR19	R/W	10*	LED19 output state control
		5:4	LDR18	R/W	10*	LED18 output state control
		3:2	LDR17	R/W	10*	LED17 output state control
		1:0	LDR16	R/W	10*	LED16 output state control
07h	LEDOUT5	7:6	LDR23	R/W	10*	LED23 output state control
		5:4	LDR22	R/W	10*	LED22 output state control
		3:2	LDR21	R/W	10*	LED21 output state control
		1:0	LDR20	R/W	10*	LED20 output state control

**LDRx = 00** — LED driver x is off (x = 0 to 23).

**LDRx = 01** — LED driver x is fully on (individual brightness and group dimming/blinking not controlled). The OE pin can be used as external dimming/blinking control in this state.

**LDRx = 10** — LED driver x individual brightness can be controlled through its PWMx register (default power-up state) or PWMALL register for all LEDn outputs.

**LDRx = 11** — LED driver x individual brightness and group dimming/blinking can be controlled through its PWMx register and the GRPPWM registers.

**Remark:** Setting the device in low power mode while being on group dimming/blinking mode may cause the LED output state to be in an unknown state after the device is set back to normal mode. The device must be reset and all register values reprogrammed.

### 7.3.4 GRPPWM, group duty cycle control

**Table 11. GRPPWM - Group brightness control register (address 08h) bit description**

Legend: \* default value

Address	Register	Bit	Symbol	Access	Value	Description
08h	GRPPWM	7:0	GDC[7:0]	R/W	1111 1111*	GRPPWM register

When DMBLNK bit (MODE2 register) is programmed with logic 0, a 122 Hz fixed frequency signal is superimposed with the 31.25 kHz individual brightness control signal. GRPPWM is then used as a global brightness control allowing the LED outputs to be dimmed with the same value. The value in GRPFREQ is then a 'Don't care'.

General brightness for the 24 outputs is controlled through 256 linear steps from 00h (0 % duty cycle = LED output off) to FFh (99.6 % duty cycle = maximum brightness). Applicable to LED outputs programmed with LDRx = 11 (LEDOUT0 to LEDOUT5 registers).

When DMBLNK bit is programmed with logic 1, GRPPWM and GRPFREQ registers define a global blinking pattern, where GRPFREQ contains the blinking period (from 67 ms to 16.8 s) and GRPPWM the duty cycle (ON/OFF ratio in %).

$$duty\ cycle = \frac{GDC[7:0]}{256} \tag{1}$$

### 7.3.5 GRPFREQ, group frequency

**Table 12. GRPFREQ - Group frequency register (address 09h) bit description**

Legend: \* default value.

Address	Register	Bit	Symbol	Access	Value	Description
09h	GRPFREQ	7:0	GFRQ[7:0]	R/W	0000 0000*	GRPFREQ register

GRPFREQ is used to program the global blinking period when DMBLNK bit (MODE2 register) is equal to 1. Value in this register is a 'Don't care' when DMBLNK = 0. Applicable to LED outputs programmed with LDRx = 11 (LEDOUT0 to LEDOUT5 registers).

Blinking period is controlled through 256 linear steps from 00h (67 ms, frequency 15 Hz) to FFh (16.8 s).

$$global\ blinking\ period = \frac{GFRQ[7:0] + 1}{15.26} (s) \tag{2}$$

7.3.6 PWM0 to PWM23, individual brightness control

Table 13. PWM0 to PWM23 - PWM registers 0 to 23 (address 0Ah to 21h) bit description  
 Legend: \* default value.

Address	Register	Bit	Symbol	Access	Value	Description
0Ah	PWM0	7:0	IDC0[7:0]	R/W	0000 0000*	PWM0 Individual Duty Cycle
0Bh	PWM1	7:0	IDC1[7:0]	R/W	0000 0000*	PWM1 Individual Duty Cycle
0Ch	PWM2	7:0	IDC2[7:0]	R/W	0000 0000*	PWM2 Individual Duty Cycle
0Dh	PWM3	7:0	IDC3[7:0]	R/W	0000 0000*	PWM3 Individual Duty Cycle
0Eh	PWM4	7:0	IDC4[7:0]	R/W	0000 0000*	PWM4 Individual Duty Cycle
0Fh	PWM5	7:0	IDC5[7:0]	R/W	0000 0000*	PWM5 Individual Duty Cycle
10h	PWM6	7:0	IDC6[7:0]	R/W	0000 0000*	PWM6 Individual Duty Cycle
11h	PWM7	7:0	IDC7[7:0]	R/W	0000 0000*	PWM7 Individual Duty Cycle
12h	PWM8	7:0	IDC8[7:0]	R/W	0000 0000*	PWM8 Individual Duty Cycle
13h	PWM9	7:0	IDC9[7:0]	R/W	0000 0000*	PWM9 Individual Duty Cycle
14h	PWM10	7:0	IDC10[7:0]	R/W	0000 0000*	PWM10 Individual Duty Cycle
15h	PWM11	7:0	IDC11[7:0]	R/W	0000 0000*	PWM11 Individual Duty Cycle
16h	PWM12	7:0	IDC12[7:0]	R/W	0000 0000*	PWM12 Individual Duty Cycle
17h	PWM13	7:0	IDC13[7:0]	R/W	0000 0000*	PWM13 Individual Duty Cycle
18h	PWM14	7:0	IDC14[7:0]	R/W	0000 0000*	PWM14 Individual Duty Cycle
19h	PWM15	7:0	IDC15[7:0]	R/W	0000 0000*	PWM15 Individual Duty Cycle
1Ah	PWM16	7:0	IDC16[7:0]	R/W	0000 0000*	PWM16 Individual Duty Cycle
1Bh	PWM17	7:0	IDC17[7:0]	R/W	0000 0000*	PWM17 Individual Duty Cycle
1Ch	PWM18	7:0	IDC18[7:0]	R/W	0000 0000*	PWM18 Individual Duty Cycle
1Dh	PWM19	7:0	IDC19[7:0]	R/W	0000 0000*	PWM19 Individual Duty Cycle
1Eh	PWM20	7:0	IDC20[7:0]	R/W	0000 0000*	PWM20 Individual Duty Cycle
1Fh	PWM21	7:0	IDC21[7:0]	R/W	0000 0000*	PWM21 Individual Duty Cycle
20h	PWM22	7:0	IDC22[7:0]	R/W	0000 0000*	PWM22 Individual Duty Cycle
21h	PWM23	7:0	IDC23[7:0]	R/W	0000 0000*	PWM23 Individual Duty Cycle

A 31.25 kHz fixed frequency signal is used for each output. Duty cycle is controlled through 256 linear steps from 00h (0 % duty cycle = LED output off) to FFh (99.6 % duty cycle = LED output at maximum brightness). Applicable to LED outputs programmed with LDRx = 10 or 11 (LEDOUT0 to LEDOUT5 registers).

$$duty\ cycle = \frac{IDC_x[7:0]}{256} \tag{3}$$

**Remark:** The first lower end 8 steps of PWM and the last (higher end) steps of PWM will not have effective brightness control of LEDs due to edge rate control of LED output pins.

### 7.3.7 IREF0 to IREF23, LED output current value registers

These registers reflect the gain settings for output current for LED0 to LED23.

**Table 14. IREF0 to IREF23 - LED output gain control registers (address 22h to 39h) bit description**

Legend: \* default value.

Address	Register	Bit	Access	Value	Description
22h	IREF0	7:0	R/W	00h*	LED0 output current setting
23h	IREF1	7:0	R/W	00h*	LED1 output current setting
24h	IREF2	7:0	R/W	00h*	LED2 output current setting
25h	IREF3	7:0	R/W	00h*	LED3 output current setting
26h	IREF4	7:0	R/W	00h*	LED4 output current setting
27h	IREF5	7:0	R/W	00h*	LED5 output current setting
28h	IREF6	7:0	R/W	00h*	LED6 output current setting
29h	IREF7	7:0	R/W	00h*	LED7 output current setting
2Ah	IREF8	7:0	R/W	00h*	LED8 output current setting
2Bh	IREF9	7:0	R/W	00h*	LED9 output current setting
2Ch	IREF10	7:0	R/W	00h*	LED10 output current setting
2Dh	IREF11	7:0	R/W	00h*	LED11 output current setting
2Eh	IREF12	7:0	R/W	00h*	LED12 output current setting
2Fh	IREF13	7:0	R/W	00h*	LED13 output current setting
30h	IREF14	7:0	R/W	00h*	LED14 output current setting
31h	IREF15	7:0	R/W	00h*	LED15 output current setting
32h	IREF16	7:0	R/W	00h*	LED16 output current setting
33h	IREF17	7:0	R/W	00h*	LED17 output current setting
34h	IREF18	7:0	R/W	00h*	LED18 output current setting
35h	IREF19	7:0	R/W	00h*	LED19 output current setting
36h	IREF20	7:0	R/W	00h*	LED20 output current setting
37h	IREF21	7:0	R/W	00h*	LED21 output current setting
38h	IREF22	7:0	R/W	00h*	LED22 output current setting
39h	IREF23	7:0	R/W	00h*	LED23 output current setting

### 7.3.8 OFFSET — LEDn output delay offset register

**Table 15. OFFSET - LEDn output delay offset register (address 3Ah) bit description**

Legend: \* default value.

Address	Register	Bit	Access	Value	Description
3Ah	OFFSET	7:4	read only	0000*	not used
		3:0	R/W	1000*	LEDn output delay offset factor

The PCA9956B can be programmed to have turn-on delay between LED outputs. This helps to reduce peak current for the V<sub>DD</sub> supply and reduces EMI.

The order in which the LED outputs are enabled will always be the same (channel 0 will enable first and channel 23 will enable last).

OFFSET control register bits [3:0] determine the delay used between the turn-on times as follows:

0000 = no delay between outputs (all on, all off at the same time)  
0001 = delay of 1 clock cycle (125 ns) between successive outputs  
0010 = delay of 2 clock cycles (250 ns) between successive outputs  
0011 = delay of 3 clock cycles (375 ns) between successive outputs  
:  
0111 = delay of 7 clock cycles (875 ns) between successive outputs  
1000 = delay of 8 clock cycles (1  $\mu$ s) between successive outputs  
1001 = delay of 9 clock cycles (1.125  $\mu$ s) between successive outputs  
1010 = delay of 10 clock cycles (1.25  $\mu$ s) between successive outputs  
1011 = delay of 11 clock cycles (1.375  $\mu$ s) between successive outputs  
1100 to 1111 = reserved and do not use

**Example:** If the value in the OFFSET register is 1000 the corresponding delay =  $8 \times 125 \text{ ns} = 1 \mu\text{s}$  delay between successive outputs.

channel 0 turns on at time 0  $\mu$ s  
channel 1 turns on at time 1  $\mu$ s  
channel 2 turns on at time 2  $\mu$ s  
channel 3 turns on at time 3  $\mu$ s  
channel 4 turns on at time 4  $\mu$ s  
channel 5 turns on at time 5  $\mu$ s  
channel 6 turns on at time 6  $\mu$ s  
channel 7 turns on at time 7  $\mu$ s  
channel 8 turns on at time 8  $\mu$ s  
channel 9 turns on at time 9  $\mu$ s  
channel 10 turns on at time 10  $\mu$ s  
channel 11 turns on at time 11  $\mu$ s  
channel 12 turns on at time 12  $\mu$ s  
channel 13 turns on at time 13  $\mu$ s  
channel 14 turns on at time 14  $\mu$ s  
channel 15 turns on at time 15  $\mu$ s  
channel 16 turns on at time 16  $\mu$ s  
channel 17 turns on at time 17  $\mu$ s  
channel 18 turns on at time 18  $\mu$ s  
channel 19 turns on at time 19  $\mu$ s  
channel 20 turns on at time 20  $\mu$ s  
channel 21 turns on at time 21  $\mu$ s  
channel 22 turns on at time 22  $\mu$ s  
channel 23 turns on at time 23  $\mu$ s

### 7.3.9 LED Sub Call I<sup>2</sup>C-bus addresses for PCA9956B

**Table 16. SUBADR1 to SUBADR3 - I<sup>2</sup>C-bus subaddress registers 1 to 3 (address 3Bh to 3Dh) bit description**

Legend: \* default value.

Address	Register	Bit	Symbol	Access	Value	Description
3Bh	SUBADR1	7:1	A1[7:1]	R/W	1110 111*	I <sup>2</sup> C-bus subaddress 1
		0	A1[0]	R only	0*	reserved
3Ch	SUBADR2	7:1	A2[7:1]	R/W	1110 111*	I <sup>2</sup> C-bus subaddress 2
		0	A2[0]	R only	0*	reserved
3Dh	SUBADR3	7:1	A3[7:1]	R/W	1110 111*	I <sup>2</sup> C-bus subaddress 3
		0	A3[0]	R only	0*	reserved

Default power-up values are EEh, EEh, EEh. At power-up, SUBADR1 is enabled while SUBADR2 and SUBADR3 are disabled. The power-up default bit subaddress of EEh indicates that this device is a 24-channel LED driver.

All three subaddresses are programmable. Once subaddresses have been programmed to their right values, SUBx bits need to be set to logic 1 in order to have the device acknowledging these addresses (MODE1 register) (0). When SUBx is set to logic 1, the corresponding I<sup>2</sup>C-bus subaddress can be used during either an I<sup>2</sup>C-bus read or write sequence.

### 7.3.10 ALLCALLADR, LED All Call I<sup>2</sup>C-bus address

**Table 17. ALLCALLADR - LED All Call I<sup>2</sup>C-bus address register (address 3Eh) bit description**

Legend: \* default value.

Address	Register	Bit	Symbol	Access	Value	Description
3Eh	ALLCALLADR	7:1	AC[7:1]	R/W	1110 000*	ALLCALL I <sup>2</sup> C-bus address register
		0	AC[0]	R only	0*	reserved

The LED All Call I<sup>2</sup>C-bus address allows all the PCA9956Bs on the bus to be programmed at the same time (ALLCALL bit in register MODE1 must be equal to logic 1 [power-up default state]). This address is programmable through the I<sup>2</sup>C-bus and can be used during either an I<sup>2</sup>C-bus read or write sequence. The register address can also be programmed as a Sub Call.

Only the 7 MSBs representing the All Call I<sup>2</sup>C-bus address are valid. The LSB in ALLCALLADR register is a read-only bit (0).

If ALLCALL bit = 0 in MODE1 register, the device does not acknowledge the address programmed in register ALLCALLADR.

### 7.3.11 PWMALL — brightness control for all LEDn outputs

When programmed, the value in this register will be used for PWM duty cycle for all the LEDn outputs and will be reflected in PWM 0 through PWM23 registers.

**Table 18. PWMALL - brightness control for all LEDn outputs register (address 3Fh) bit description**

Legend: \* default value.

Address	Register	Bit	Access	Value	Description
3Fh	PWMALL	7:0	write only	0000 0000*	duty cycle for all LEDn outputs

**Remark:** Write to any of the PWM0 to PWM23 registers will overwrite the value in corresponding PWMn register programmed by PWMALL.

### 7.3.12 IREFALL register: output current value for all LED outputs

The output current setting for all outputs is held in this register. When this register is written to or updated, all LED outputs will be set to a current corresponding to this register value.

Writes to IREF0 to IREF23 will overwrite the output current settings.

**Table 19. IREFALL - Output gain control for all LED outputs (address 40h) bit description**

Legend: \* default value.

Address	Register	Bit	Access	Value	Description
40h	IREFALL	7:0	write only	00h*	Current gain setting for all LED outputs.

### 7.3.13 LED driver constant current outputs

In LED display applications, PCA9956B provides nearly no current variations from channel to channel and from device to device. The maximum current skew between channels is less than ±4 % and less than ±6 % between devices.

#### 7.3.13.1 Adjusting output current

The PCA9956B scales up the reference current ( $I_{ref}$ ) set by the external resistor ( $R_{ext}$ ) to sink the output current ( $I_O$ ) at each output port. The maximum output current for the outputs can be set using  $R_{ext}$ . In addition, the constant value for current drive at each of the outputs is independently programmable using command registers IREF0 to IREF23. Alternatively, programming the IREFALL register allows all outputs to be set at one current value determined by the value in IREFALL register.

[Equation 4](#) and [Equation 5](#) can be used to calculate the minimum and maximum constant current values that can be programmed for the outputs for a chosen  $R_{ext}$ .

$$I_{O\_LED\_MIN} = \frac{900 \text{ mV}}{R_{ext}} \times \frac{1}{4} \text{ (minimum constant current)} \tag{4}$$

$$I_{O\_LED\_MAX} = (255 \times I_{O\_LED\_MIN}) = \left( \frac{900 \text{ mV}}{R_{ext}} \times \frac{255}{4} \right) \tag{5}$$

For a given IREFx setting,  $I_{O\_LED} = IREFx \times \frac{900 \text{ mV}}{R_{ext}} \times \frac{1}{4}$ .

**Remark:** The open/short circuit source voltage is influenced by the external resistor  $R_{ext}$  and may falsely trigger the open condition if  $R_{ext}$  is bigger than 3.6 k $\Omega$ . Use 3 k $\Omega$  or smaller  $R_{ext}$  to guarantee no false open triggers; if smaller analog currents are required with  $R_{ext}$  larger than 3 k $\Omega$  then don't use the open/short detection.

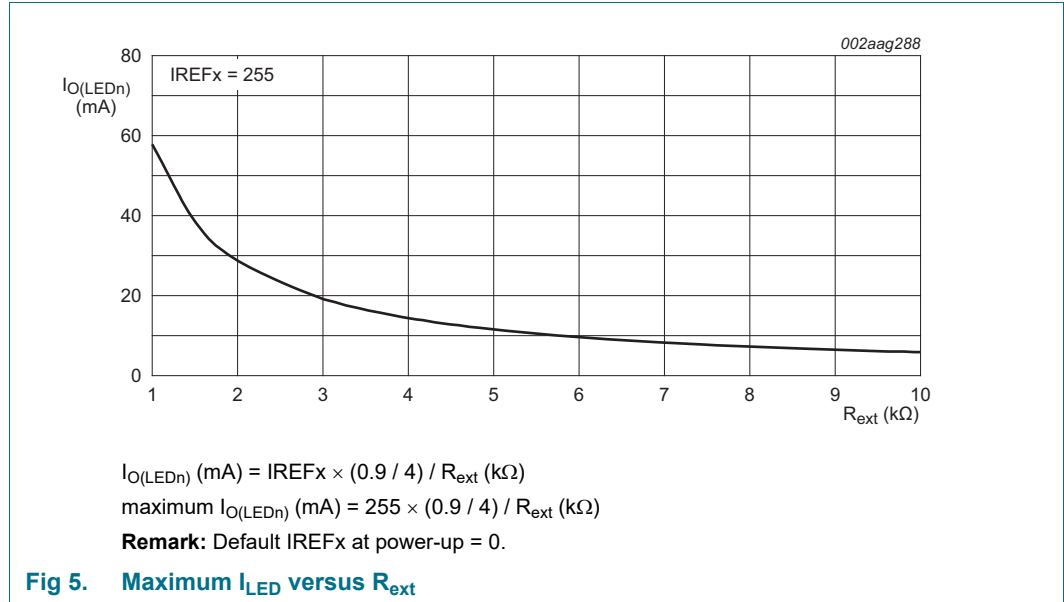

**Example 1:** If  $R_{ext} = 1 \text{ k}\Omega$ ,  $I_{O\_LED\_MIN} = 225 \mu\text{A}$ ,  $I_{O\_LED\_MAX} = 57.375 \text{ mA}$  (as shown in [Figure 6](#)).

So each channel can be programmed with its individual  $I_{REFx}$  in 256 steps and in 225  $\mu\text{A}$  increments to a maximum output current of 57.375 mA independently.

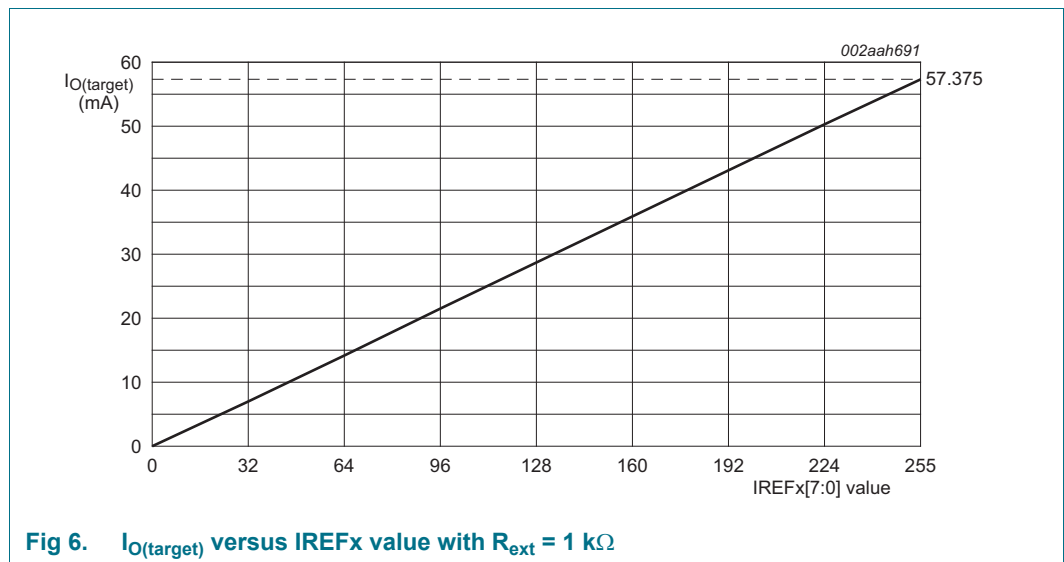

**Example 2:** If  $R_{ext} = 2 \text{ k}\Omega$ ,  $I_{O\_LED\_MIN} = 112.5 \mu\text{A}$ ,  $I_{O\_LED\_MAX} = 28.687 \text{ mA}$  (as shown in [Figure 7](#)).

So each channel can be programmed with its individual  $I_{REFx}$  in 256 steps and in 112.5  $\mu\text{A}$  increments to a maximum output channel of 28.687 mA independently.



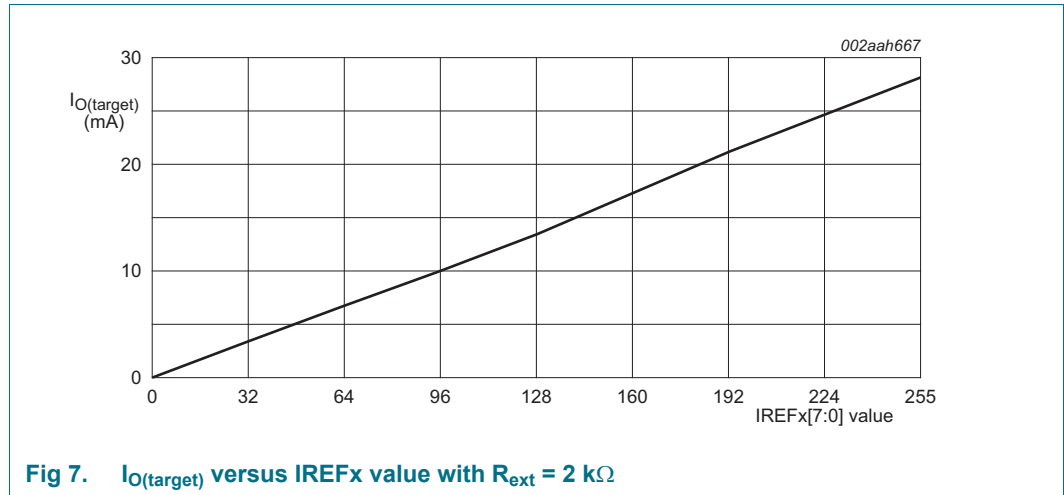

Fig 7. I<sub>O(target)</sub> versus IREFx value with R<sub>ext</sub> = 2 kΩ

### 7.3.14 LED error detection

The PCA9956B is capable of detecting an LED open or a short condition at its open-drain LED outputs. Users will recognize these faults by reading the status of a pair of error bits (ERRx) in error flag registers (EFLAGn) for each channel. Both LDRx value in LEDOUTx registers and IREFx value must be set to '00' for those unused LED output channels. If the output is selected to be fully on, individual dim, or individual and group dim, that channel will be tested.

The user can poll the ERROR status bit (bit 6 in MODE2 register) to check if there is a fault condition in any of the 24 channels. The EFLAGn registers can then be read to determine which channels are at fault and the type of fault in those channels. The error status reported by the EFLAGn register is real time information that will get self cleared once the error is fixed and write '1' to CLRERR (bit 4 in MODE2 register).

**Remark:** Checks for open and short-circuit will not occur if the PWM value in PWM0 to PWM23 registers is less than 8.

**Remark:** The open/short circuit source voltage is influenced by the external resistor R<sub>ext</sub> and may falsely trigger the open condition if R<sub>ext</sub> is bigger than 3.6 kΩ. Use 3 kΩ or smaller R<sub>ext</sub> to guarantee no false open triggers; if smaller analog currents are required with R<sub>ext</sub> larger than 3 kΩ then don't use the open/short detection.

Table 20. EFLAG0 to EFLAG5 - Error flag registers (address 41h to 46h) bit description

Legend: \* default value.

Address	Register	Bit	Symbol	Access	Value	Description
41h	EFLAG0	7:6	ERR3	R only	00*	Error status for LED3 output
		5:4	ERR2	R only	00*	Error status for LED2 output
		3:2	ERR1	R only	00*	Error status for LED1 output
		1:0	ERR0	R only	00*	Error status for LED0 output
42h	EFLAG1	7:6	ERR7	R only	00*	Error status for LED7 output
		5:4	ERR6	R only	00*	Error status for LED6 output
		3:2	ERR5	R only	00*	Error status for LED5 output
		1:0	ERR4	R only	00*	Error status for LED4 output

**Table 20. EFLAG0 to EFLAG5 - Error flag registers (address 41h to 46h) bit description**  
...continued

Address	Register	Bit	Symbol	Access	Value	Description
43h	EFLAG2	7:6	ERR11	R only	00*	Error status for LED11 output
		5:4	ERR10	R only	00*	Error status for LED10 output
		3:2	ERR9	R only	00*	Error status for LED9 output
		1:0	ERR8	R only	00*	Error status for LED8 output
44h	EFLAG3	7:6	ERR15	R only	00*	Error status for LED15 output
		5:4	ERR14	R only	00*	Error status for LED14 output
		3:2	ERR13	R only	00*	Error status for LED13 output
		1:0	ERR12	R only	00*	Error status for LED12 output
45h	EFLAG4	7:6	ERR19	R only	00*	Error status for LED19 output
		5:4	ERR18	R only	00*	Error status for LED18 output
		3:2	ERR17	R only	00*	Error status for LED17 output
		1:0	ERR16	R only	00*	Error status for LED16 output
46h	EFLAG5	7:6	ERR23	R only	00*	Error status for LED23 output
		5:4	ERR22	R only	00*	Error status for LED22 output
		3:2	ERR21	R only	00*	Error status for LED21 output
		1:0	ERR20	R only	00*	Error status for LED20 output

**Table 21. ERRx bit description**

LED error detection status	ERRx		Description
	Bit 1	Bit 0	
No error	0	0	In normal operation and no error
Short-circuit	0	1	Detected LED short-circuit condition
Open-circuit	1	0	Detected LED open-circuit condition
DNE (Do Not Exist)	1	1	This condition does not exist

**7.3.14.1 Open-circuit detection principle**

The PCA9956B LED open-circuit detection compares the effective current level  $I_O$  with the open load detection threshold current  $I_{th(det)}$ . If  $I_O$  is below the threshold  $I_{th(det)}$ , the PCA9956B detects an open load condition. This error status can be read out as an error flag through the EFLAGn registers. For open-circuit error detection of an output channel, that channel must be ON.

**Table 22. Open-circuit detection**

State of output port	Condition of output current	Error status code	Description
OFF	$I_O = 0$ mA	0	detection not possible
ON	$I_O < I_{th(det)}$ <sup>[1]</sup>	1	open-circuit
	$I_O \geq I_{th(det)}$ <sup>[1]</sup>	this channel open error status bit is 0	normal

[1]  $I_{th(det)} = 0.5 \times I_{O(target)}$  (typical). This threshold may be different for each I/O and only depends on IREFx and R<sub>ext</sub>.

7.3.14.2 Short-circuit detection principle

The LED short-circuit detection compares the effective output voltage level ( $V_O$ ) with the shorted-load detection threshold voltages  $V_{th(trig)}$ . If  $V_O$  is above the  $V_{th(trig)}$  threshold, the PCA9956B detects a shorted-load condition. If  $V_O$  is below the  $V_{th(trig)}$  threshold, no error is detected and error bit is set to '0'. This error status can be read out as an error flag through the EFLAGn registers. For short-circuit error detection of an output channel, that channel must be ON.

Table 23. Short-circuit detection

State of output port	Condition of output voltage	Error status code	Description
OFF	-	0	detection not possible
ON	$V_O \geq V_{th(trig)}$ <sup>[1]</sup>	1	short-circuit
	$V_O < V_{th(trig)}$ <sup>[1]</sup>	this channel short error status bit is 0	normal

[1]  $V_{th} \approx 2.85 V$ .

**Remark:** The error status distinguishes between an LED short condition and an LED open condition. Upon detecting an LED short or open, the corresponding LED outputs should be turned OFF to prevent heat dissipation for a short in the chip. Although an open event will not be harmful, the outputs should be turned OFF for both occasions to repair the LED string.

7.3.15 Overtemperature protection

If the PCA9956B chip temperature exceeds its limit ( $T_{max}$ , see [Table 26](#)), all output channels will be disabled until the temperature drops below its limit minus a small hysteresis ( $T_{hys}$ , see [Table 26](#)). When an overtemperature situation is encountered, the OVERTEMP flag (bit 7) is set in the MODE2 register. Once the die temperature reduces below the  $T_{max} - T_{hys}$ , the chip will return to the same condition it was prior to the overtemperature event and the OVERTEMP flag will be cleared.

## 7.4 Active LOW output enable input

The active LOW output enable ( $\overline{\text{OE}}$ ) pin on PCA9956B allows to enable or disable all the LED outputs at the same time.

- When a LOW level is applied to  $\overline{\text{OE}}$  pin, all the LED outputs are enabled.
- When a HIGH level is applied to  $\overline{\text{OE}}$  pin, all the LED outputs are high-impedance.

The  $\overline{\text{OE}}$  pin can be used as a synchronization signal to switch on/off several PCA9956B devices at the same time when LED drive output state is set fully ON (LDRx = 01 in LEDOUTx register) in these devices. This requires an external clock reference that provides blinking period and the duty cycle.

The  $\overline{\text{OE}}$  pin can also be used as an external dimming control signal. The frequency of the external clock must be high enough not to be seen by the human eye, and the duty cycle value determines the brightness of the LEDs.

**Remark:** Do not use  $\overline{\text{OE}}$  as an external blinking control signal when internal global blinking is selected (DMBLNK = 1, MODE2 register) since it will result in an undefined blinking pattern. Do not use  $\overline{\text{OE}}$  as an external dimming control signal when internal global dimming is selected (DMBLNK = 0, MODE2 register) since it will result in an undefined dimming pattern.

## 7.5 Power-on reset

When power is applied to  $V_{\text{DD}}$ , an internal power-on reset holds the PCA9956B in a reset condition until  $V_{\text{DD}}$  has reached  $V_{\text{POR}}$ . At this point, the reset condition is released and the PCA9956B registers and I<sup>2</sup>C-bus state machine are initialized to their default states (all zeroes) causing all the channels to be deselected. Thereafter,  $V_{\text{DD}}$  must be pulled lower than 1 V and stay LOW for longer than 20  $\mu\text{s}$ . The device will reset itself, and allow 2 ms for the device to fully wake up.

## 7.6 Hardware reset recovery

When a reset of PCA9956B is activated using an active LOW input on the  $\overline{\text{RESET}}$  pin, a reset pulse width of 2.5  $\mu\text{s}$  minimum is required. The maximum wait time after  $\overline{\text{RESET}}$  pin is released is 1.5 ms.

### 7.7 Software reset

The Software Reset Call (SWRST Call) allows all the devices in the I<sup>2</sup>C-bus to be reset to the power-up state value through a specific formatted I<sup>2</sup>C-bus command. To be performed correctly, it implies that the I<sup>2</sup>C-bus is functional and that there is no device hanging the bus.

The maximum wait time after software reset is 1 ms.

The SWRST Call function is defined as the following:

1. A START command is sent by the I<sup>2</sup>C-bus master.
2. The reserved General Call address '0000 000' with the R/W bit set to '0' (write) is sent by the I<sup>2</sup>C-bus master.
3. The PCA9956B device(s) acknowledge(s) after seeing the General Call address '0000 0000' (00h) only. If the R/W bit is set to '1' (read), no acknowledge is returned to the I<sup>2</sup>C-bus master.
4. Once the General Call address has been sent and acknowledged, the master sends 1 byte with 1 specific value (SWRST data byte 1):
  - a. Byte 1 = 06h: the PCA9956B acknowledges this value only. If byte 1 is not equal to 06h, the PCA9956B does not acknowledge it.

If more than 1 byte of data is sent, the PCA9956B does not acknowledge any more.
5. Once the correct byte (SWRST data byte 1) has been sent and correctly acknowledged, the master sends a STOP command to end the SWRST function: the PCA9956B then resets to the default value (power-up value) and is ready to be addressed again within the specified bus free time (t<sub>BUF</sub>).

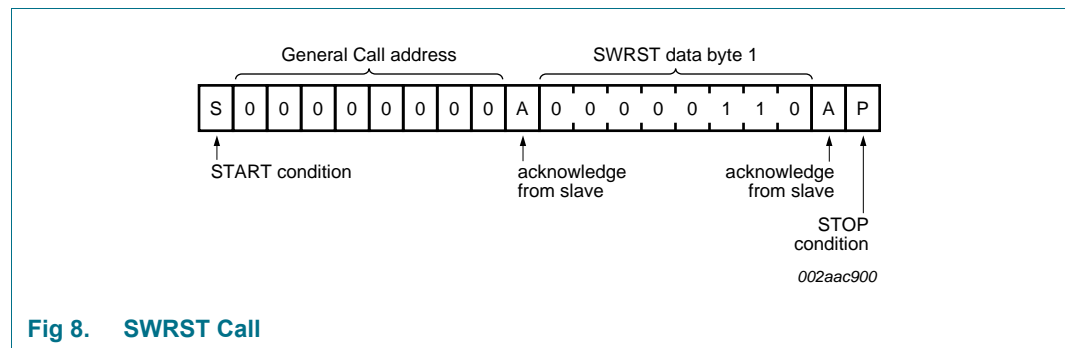

The I<sup>2</sup>C-bus master must interpret a non-acknowledge from the PCA9956B (at any time) as a 'SWRST Call Abort'. The PCA9956B does not initiate a reset of its registers. This happens only when the format of the SWRST Call sequence is not correct.

### 7.8 Individual brightness control with group dimming/blinking

A 31.25 kHz fixed frequency signal with programmable duty cycle (8 bits, 256 steps) is used to control individually the brightness for each LED.

On top of this signal, one of the following signals can be superimposed (this signal can be applied to the 24 LED outputs LED0 to LED23).

- A lower 122 Hz fixed frequency signal with programmable duty cycle (8 bits, 256 steps) is used to provide a global brightness control.
- A programmable frequency signal from 15 Hz to every 16.8 seconds (8 bits, 256 steps) with programmable duty cycle (8 bits, 256 steps) is used to provide a global blinking control.

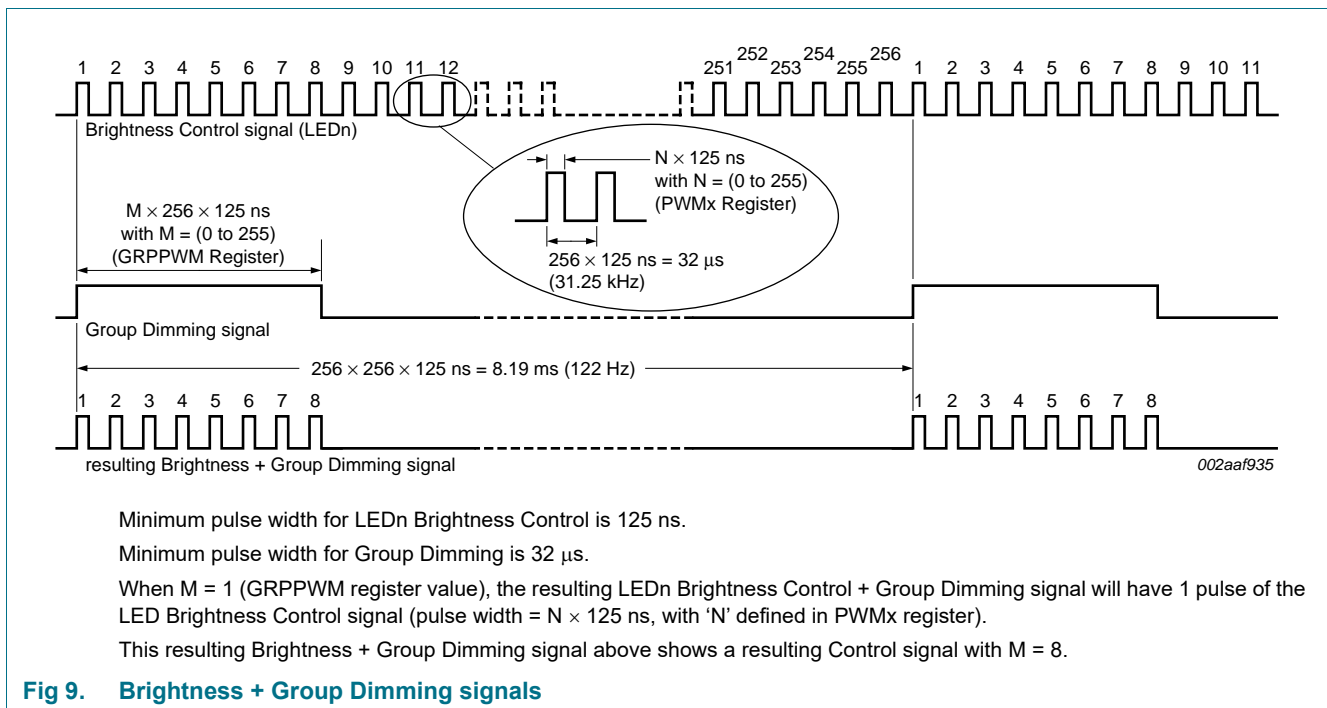

Fig 9. Brightness + Group Dimming signals

## 8. Characteristics of the I<sup>2</sup>C-bus

The I<sup>2</sup>C-bus is for 2-way, 2-line communication between different ICs or modules. The two lines are a serial data line (SDA) and a serial clock line (SCL). Both lines must be connected to a positive supply via a pull-up resistor when connected to the output stages of a device. Data transfer may be initiated only when the bus is not busy.

### 8.1 Bit transfer

One data bit is transferred during each clock pulse. The data on the SDA line must remain stable during the HIGH period of the clock pulse as changes in the data line at this time will be interpreted as control signals (see [Figure 10](#)).

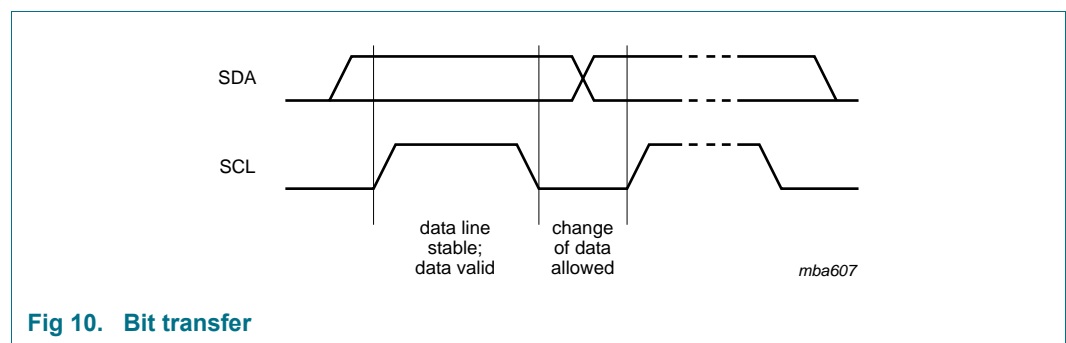

Fig 10. Bit transfer

#### 8.1.1 START and STOP conditions

Both data and clock lines remain HIGH when the bus is not busy. A HIGH-to-LOW transition of the data line while the clock is HIGH is defined as the START condition (S). A LOW-to-HIGH transition of the data line while the clock is HIGH is defined as the STOP condition (P) (see [Figure 11](#)).

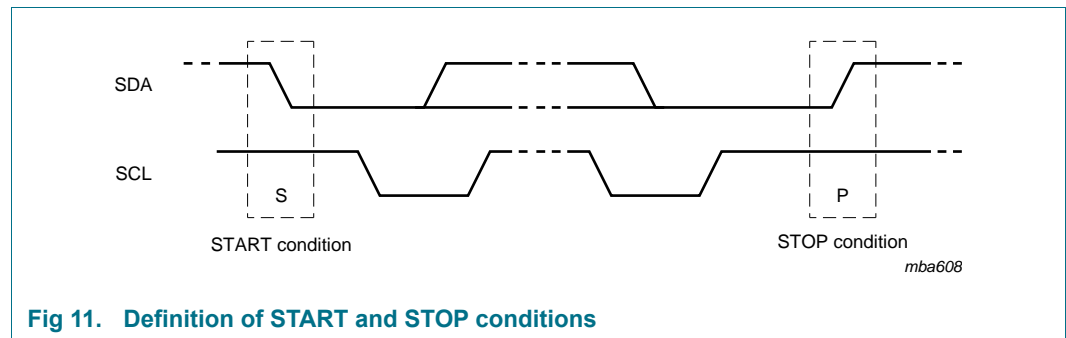

Fig 11. Definition of START and STOP conditions

### 8.2 System configuration

A device generating a message is a 'transmitter'; a device receiving is the 'receiver'. The device that controls the message is the 'master' and the devices which are controlled by the master are the 'slaves' (see [Figure 12](#)).

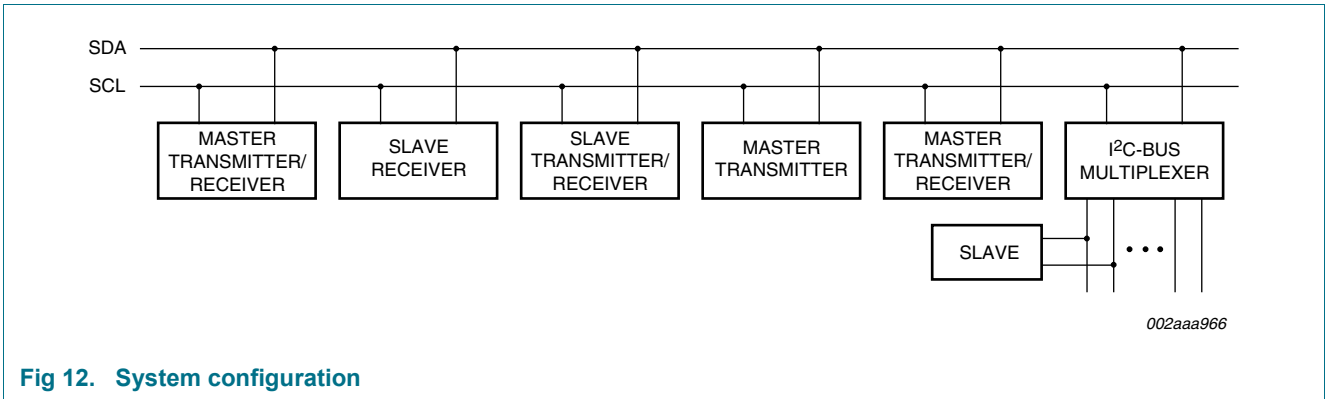

Fig 12. System configuration

### 8.3 Acknowledge

The number of data bytes transferred between the START and the STOP conditions from transmitter to receiver is not limited. Each byte of eight bits is followed by one acknowledge bit. The acknowledge bit is a HIGH level put on the bus by the transmitter, whereas the master generates an extra acknowledge related clock pulse.

A slave receiver which is addressed must generate an acknowledge after the reception of each byte. Also a master must generate an acknowledge after the reception of each byte that has been clocked out of the slave transmitter. The device that acknowledges has to pull down the SDA line during the acknowledge clock pulse, so that the SDA line is stable LOW during the HIGH period of the acknowledge related clock pulse; set-up time and hold time must be taken into account.

A master receiver must signal an end of data to the transmitter by not generating an acknowledge on the last byte that has been clocked out of the slave. In this event, the transmitter must leave the data line HIGH to enable the master to generate a STOP condition.

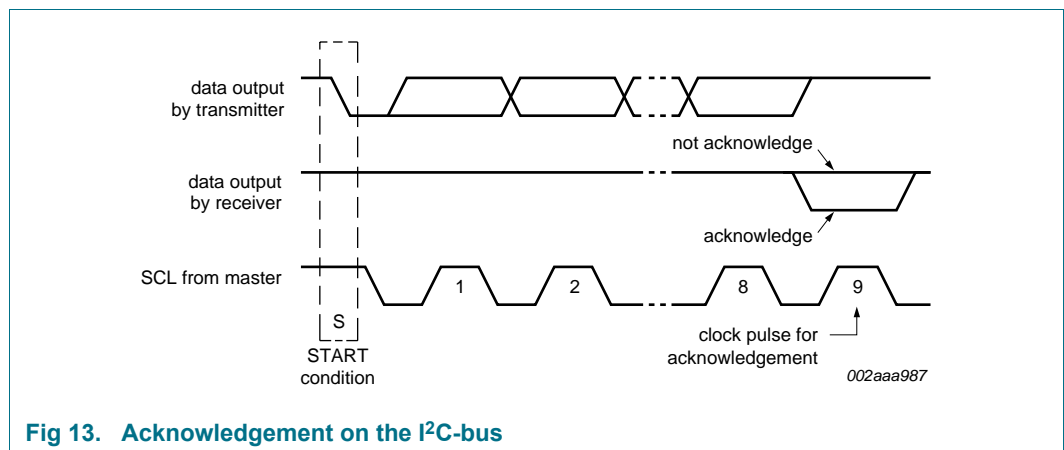
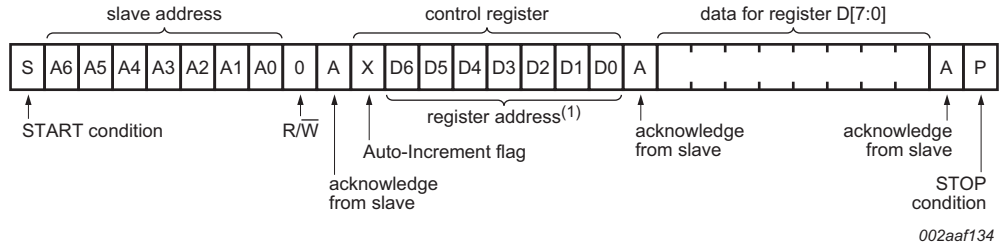

Fig 13. Acknowledgement on the I<sup>2</sup>C-bus



## 9. Bus transactions



(1) See [Table 7](#) for register definition.

**Fig 14. Write to a specific register**

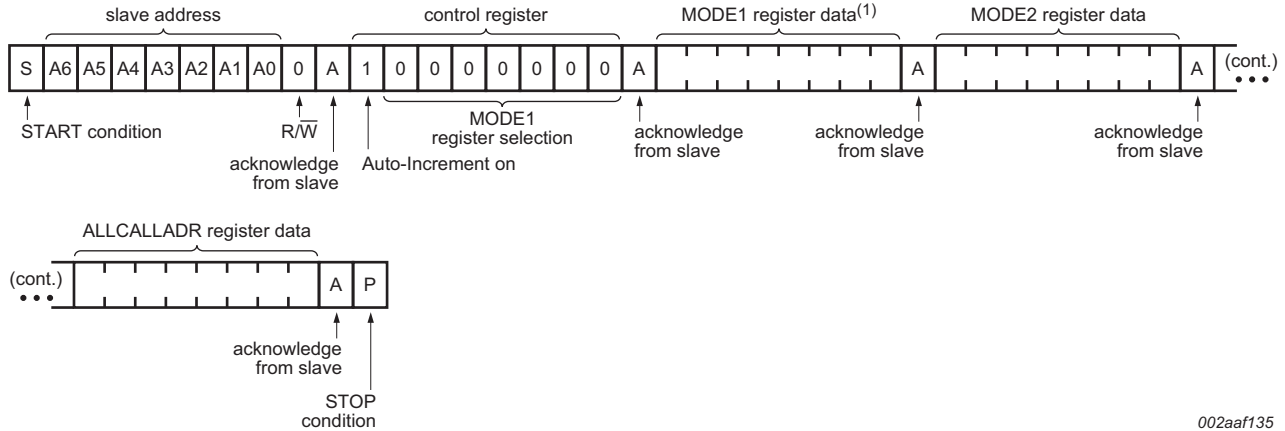

(1) AI1, AI0 = 00. See [Table 6](#) for Auto-Increment options.

**Remark:** Care should be taken to load the appropriate value here in the AI1 and AI0 bits of the MODE1 register for programming the part with the required Auto-Increment options.

**Fig 15. Write to all registers using the Auto-Increment feature**

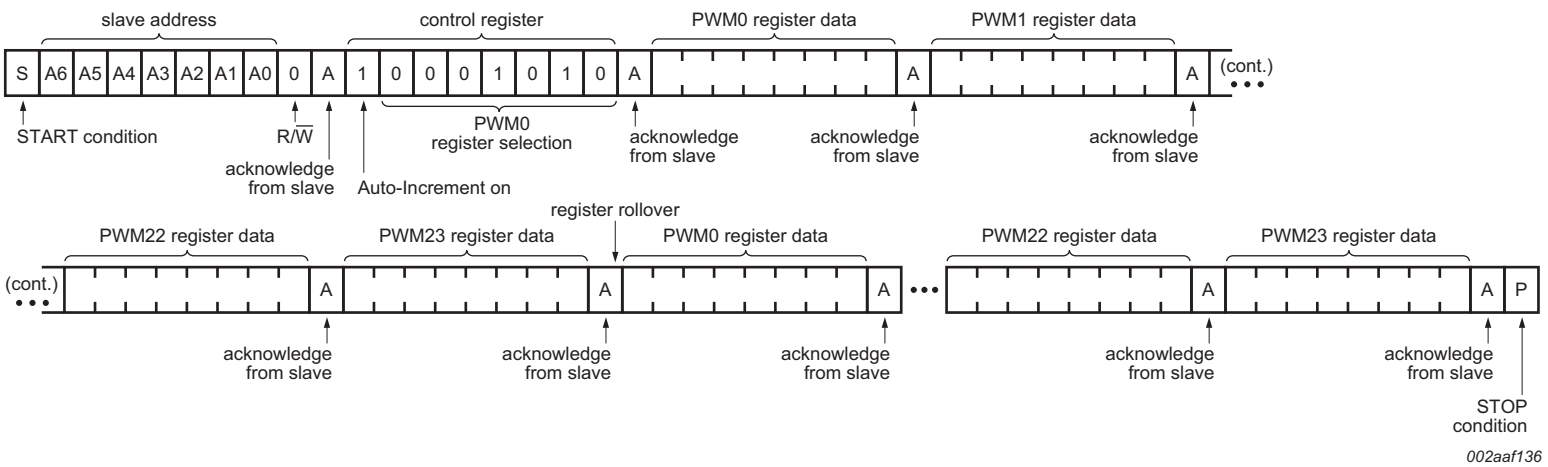

This example assumes that AIF + AI[1:0] = 101b.

**Fig 16. Multiple writes to Individual Brightness registers only using the Auto-Increment feature**

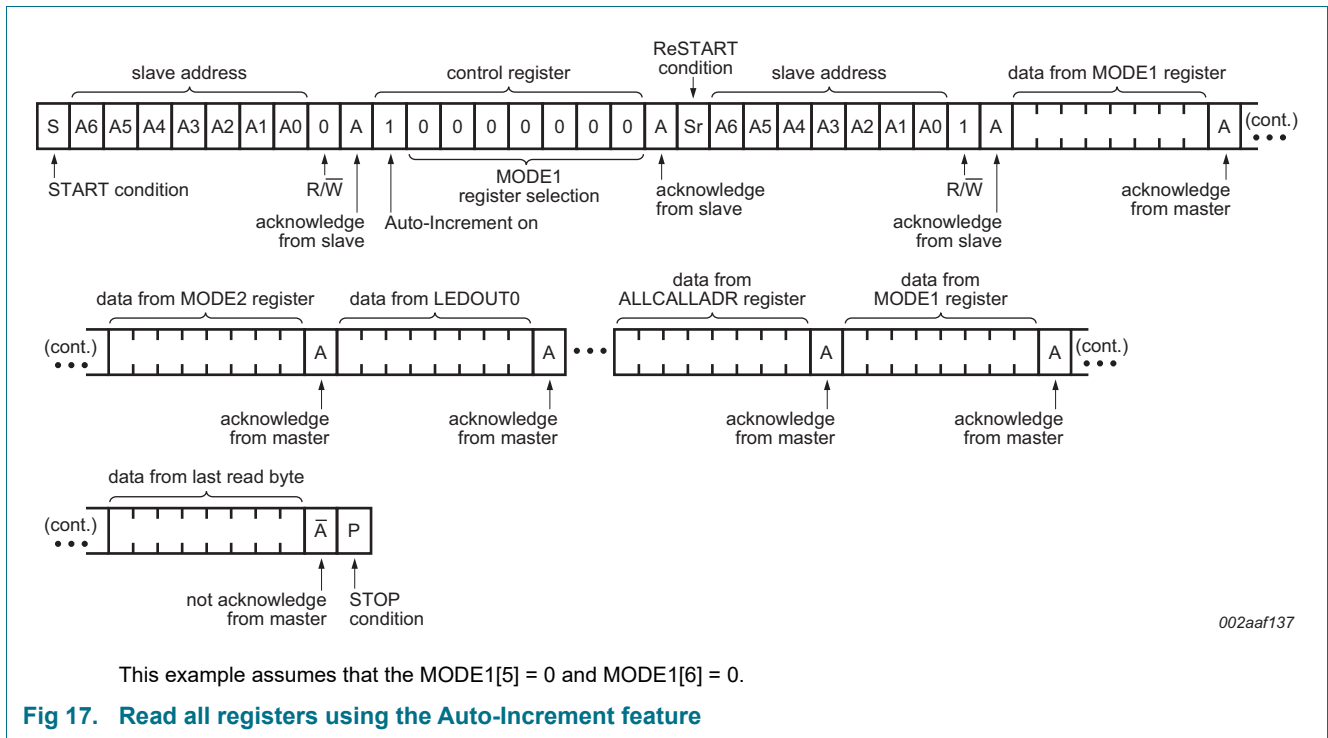
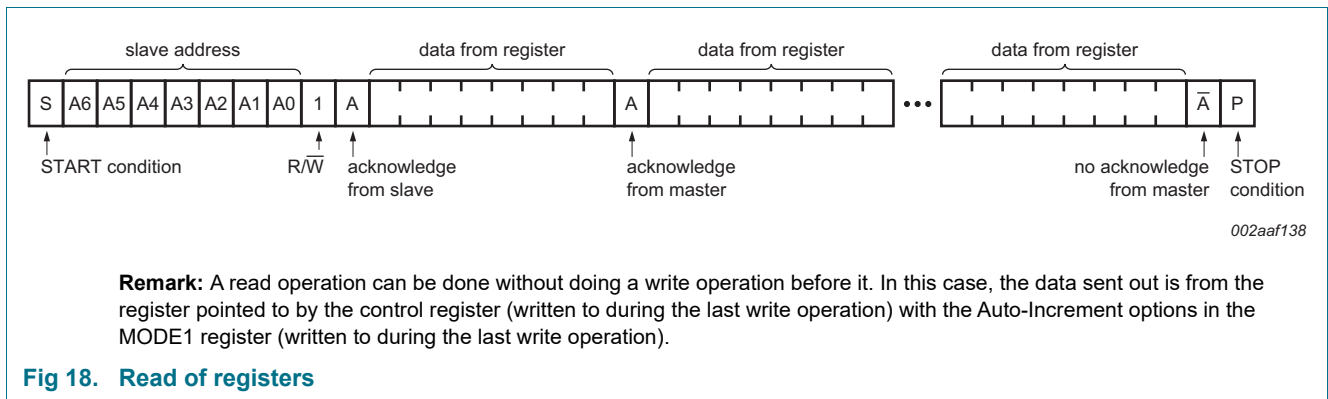
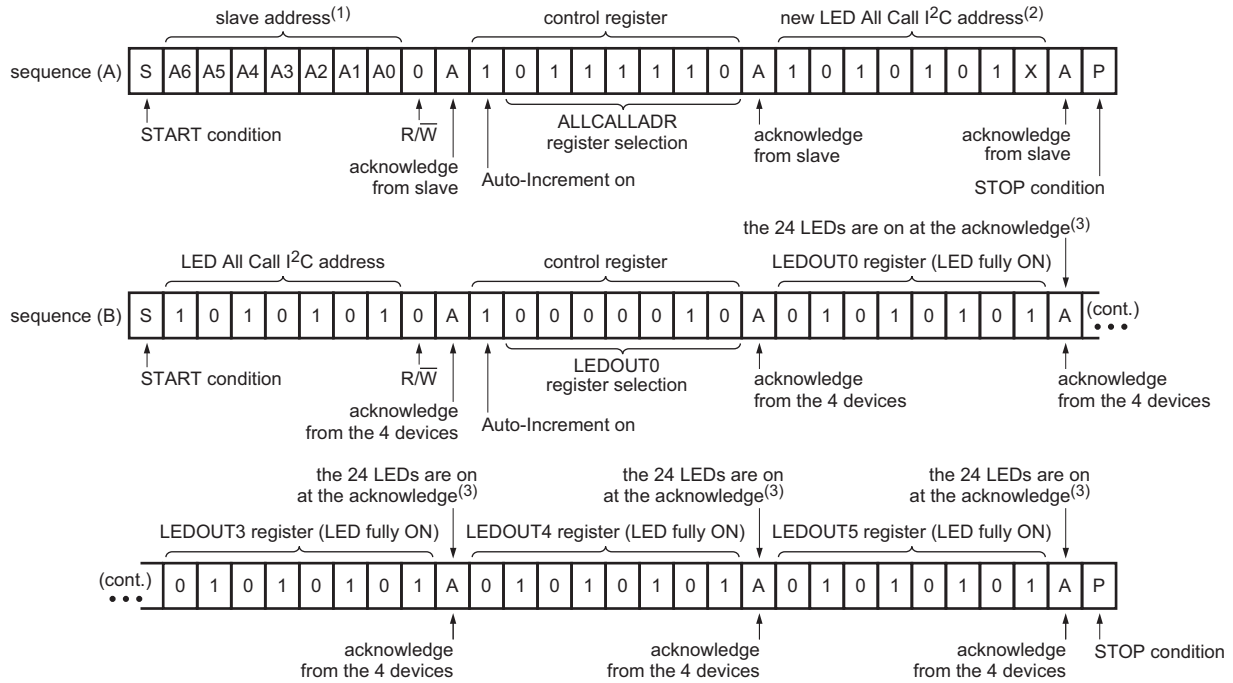

Fig 17. Read all registers using the Auto-Increment feature



**Remark:** A read operation can be done without doing a write operation before it. In this case, the data sent out is from the register pointed to by the control register (written to during the last write operation) with the Auto-Increment options in the MODE1 register (written to during the last write operation).

Fig 18. Read of registers



002aaf139

- (1) In this example, several PCA9956Bs are used and the same sequence (A) (above) is sent to each of them.
- (2) ALLCALL bit in MODE1 register is previously set to 1 for this example.
- (3) OCH bit in MODE2 register is previously set to 1 for this example.

**Fig 19. LED All Call I<sup>2</sup>C-bus address programming and LED All Call sequence example**

## 10. Application design-in information

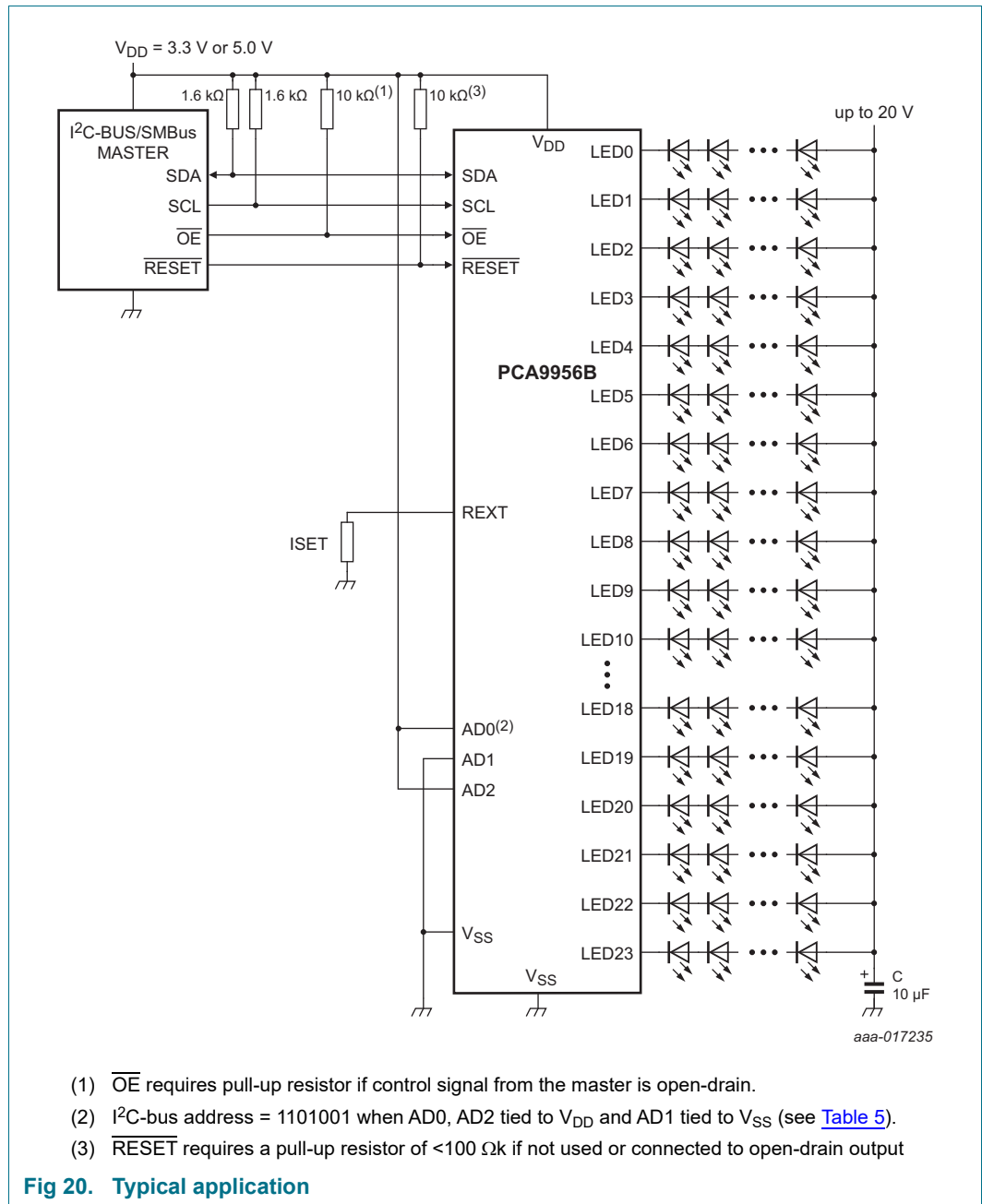

### 10.1 Thermal considerations

Since the PCA9956B device integrates 24 linear current sources, thermal considerations should be taken into account to prevent overheating, which can cause the device to go into thermal shutdown.

Perhaps the major contributor for device's overheating is the LED forward voltage mismatch. This is because it can cause significant voltage differences between the LED strings of the same type (e.g., 2 V to 3 V), which ultimately translates into higher power

dissipation in the device. The voltage drop across the LED channels of the device is given by the difference between the supply voltage and the LED forward voltage of each LED string. Reducing this to a minimum (e.g., 0.8 V) helps to keep the power dissipation down. Therefore LEDs binning is recommended to minimize LED voltage forward variation and reduce power dissipation in the device.

In order to ensure that the device will not go into thermal shutdown when operating under certain application conditions, its junction temperature ( $T_j$ ) should be calculated to ensure that is below the overtemperature threshold limit (130 °C). The  $T_j$  of the device depends on the ambient temperature ( $T_{amb}$ ), device's total power dissipation ( $P_{tot}$ ), and thermal resistance.

The device junction temperature can be calculated by using the following equation:

$$T_j = T_{amb} + R_{th(j-a)} \times P_{tot} \quad (6)$$

where:

$T_j$  = junction temperature

$T_{amb}$  = ambient temperature

$R_{th(j-a)}$  = junction to ambient thermal resistance

$P_{tot}$  = (device) total power dissipation

An example of this calculation is show below:

**Conditions:**

$T_{amb} = 50 \text{ °C}$

$R_{th(j-a)} = 33.9 \text{ °C/W}$  (per JEDEC 51 standard for multilayer PCB)

$I_{LED} = 30 \text{ mA / channel}$

$I_{DD(max)} = 20 \text{ mA}$

$V_{DD} = 5 \text{ V}$

LEDs per channel = 5 LEDs / channel

LED  $V_{F(typ)} = 3 \text{ V}$  per LED (15 V total for 5 LEDs in series)

LED  $V_F$  mismatch = 0.2 V per LED (1 V total for 5 LEDs in series)

$V_{reg(drv)} = 0.8 \text{ V}$  (This will be present only in the LED string with the highest LED forward voltage.)

$V_{sup} = \text{LED } V_{F(typ)} + \text{LED } V_F \text{ mismatch} + V_{reg(drv)} = 15 \text{ V} + 1 \text{ V} + 0.8 \text{ V} = 16.8 \text{ V}$

**P<sub>tot</sub> calculation:**

$$P_{\text{tot}} = \text{IC\_power} + \text{LED drivers\_power};$$

$$\text{IC\_power} = (I_{\text{DD}} \times V_{\text{DD}}) + (\text{SDA\_V}_{\text{OL}} \times I_{\text{OL}})$$

$$\text{IC\_power} = (0.02 \text{ A} \times 5 \text{ V}) + (0.4 \text{ V} \times 0.03 \text{ A}) = 0.112 \text{ W}$$

$$\text{LED drivers\_power} = [(24 - 1) \times (I_{\text{LED}}) \times (\text{LED } V_{\text{F}} \text{ mismatch} + V_{\text{reg(drv)}})] + (I_{\text{LED}} \times V_{\text{reg(drv)}})$$

$$\text{LED drivers\_power} = [23 \times 0.03 \text{ A} \times (1 \text{ V} + 0.8 \text{ V})] + (0.03 \text{ A} \times 0.8 \text{ V}) = 1.266 \text{ W}$$

$$P_{\text{tot}} = 0.112 \text{ W} + 1.266 \text{ W} = 1.378 \text{ W}$$

**T<sub>j</sub> calculation:**

$$T_{\text{j}} = T_{\text{amb}} + R_{\text{th(j-a)}} \times P_{\text{tot}}$$

$$T_{\text{j}} = 50 \text{ }^{\circ}\text{C} + (33.9 \text{ }^{\circ}\text{C/W} \times 1.378 \text{ W}) = 96.71 \text{ }^{\circ}\text{C}$$

This confirms that the junction temperature is below the minimum overtemperature threshold of 130 °C, which ensures the device will not go into thermal shutdown under these conditions.

It is important to mention that the value of the thermal resistance junction-to-ambient ( $R_{\text{th(j-a)}}$ ) strongly depends in the PCB design. Therefore, the thermal pad of the device should be attached to a big enough PCB copper area to ensure proper thermal dissipation (similar to JEDEC 51 standard). Several thermal vias in the PCB thermal pad should be used as well to increase the effectiveness of the heat dissipation (e.g., 15 thermal vias). The thermal vias should be distributed evenly in the PCB thermal pad.

Finally, it is important to point out that this calculation should be taken as a reference only and therefore evaluations should still be performed under the application environment and conditions to confirm proper system operation.

## 11. Limiting values

**Table 24. Limiting values**

In accordance with the Absolute Maximum Rating System (IEC 60134).

Symbol	Parameter	Conditions	Min	Max	Unit
V <sub>DD</sub>	supply voltage		-0.5	+6.0	V
V <sub>I/O</sub>	voltage on an input/output pin		V <sub>SS</sub> - 0.5	5.5	V
V <sub>drv(LED)</sub>	LED driver voltage		V <sub>SS</sub> - 0.5	20	V
I <sub>O(LEDn)</sub>	output current on pin LEDn		-	65	mA
I <sub>SS</sub>	ground supply current		-	2.5	A
P <sub>tot</sub>	total power dissipation	T <sub>amb</sub> = 25 °C	-	2.95	W
		T <sub>amb</sub> = 85 °C	-	1.18	W
T <sub>stg</sub>	storage temperature		-65	+150	°C
T <sub>amb</sub>	ambient temperature	operating	-40	+85	°C
T <sub>j</sub>	junction temperature		-40	+125	°C

## 12. Thermal characteristics

**Table 25. Thermal characteristics**

Symbol	Parameter	Conditions	Typ	Unit
R <sub>th(j-a)</sub>	thermal resistance from junction to ambient	HTSSOP38	[1] 33.9	°C/W

[1] Per JEDEC 51 standard for multilayer PCB and Wind Speed (m/s) = 0.



### 13. Static characteristics

**Table 26. Static characteristics**

$V_{DD} = 3\text{ V to }5.5\text{ V}$ ;  $V_{SS} = 0\text{ V}$ ;  $T_{amb} = -40\text{ °C to }+85\text{ °C}$ ; unless otherwise specified.

Symbol	Parameter	Conditions	Min	Typ <sup>[1]</sup>	Max	Unit
<b>Supply</b>						
$V_{DD}$	supply voltage		3	-	5.5	V
$I_{DD}$	supply current	on pin $V_{DD}$ ; operating mode; $f_{SCL} = 1\text{ MHz}$				
		$R_{ext} = 2\text{ k}\Omega$ ; LED[23:0] = off; IREF <sub>x</sub> = 00h	-	11	12	mA
		$R_{ext} = 1\text{ k}\Omega$ ; LED[23:0] = off; IREF <sub>x</sub> = 00h	-	13	14	mA
		$R_{ext} = 2\text{ k}\Omega$ ; LED[23:0] = on; IREF <sub>x</sub> = FFh	-	15	19	mA
		$R_{ext} = 1\text{ k}\Omega$ ; LED[23:0] = on; IREF <sub>x</sub> = FFh	-	17	21	mA
$I_{stb}$	standby current	on pin $V_{DD}$ ; no load; $f_{SCL} = 0\text{ Hz}$ ; MODE1[4] = 1; $V_I = V_{DD}$				
		$V_{DD} = 3.3\text{ V}$	-	100	600	$\mu\text{A}$
		$V_{DD} = 5.5\text{ V}$	-	100	700	$\mu\text{A}$
$V_{POR}$	power-on reset voltage	no load; $V_I = V_{DD}$ or $V_{SS}$	-	2	-	V
$V_{PDR}$	power-down reset voltage	no load; $V_I = V_{DD}$ or $V_{SS}$	<sup>[2][3]</sup> -	1	-	V
<b>Input SCL; input/output SDA</b>						
$V_{IL}$	LOW-level input voltage		-0.5	-	+0.3 $V_{DD}$	V
$V_{IH}$	HIGH-level input voltage		0.7 $V_{DD}$	-	5.5	V
$I_{OL}$	LOW-level output current	$V_{OL} = 0.4\text{ V}$ ; $V_{DD} = 3\text{ V}$	20	-	-	mA
		$V_{OL} = 0.4\text{ V}$ ; $V_{DD} = 5\text{ V}$	30	-	-	mA
$I_L$	leakage current	$V_I = V_{DD}$ or $V_{SS}$	-1	-	+1	$\mu\text{A}$
$C_i$	input capacitance	$V_I = V_{SS}$	-	6	10	pF
<b>Current controlled outputs (LED[23:0])</b>						
$I_{O(LEDn)}$	output current on pin LED <sub>n</sub>	$V_O = 0.8\text{ V}$ ; IREF <sub>x</sub> = 80h; $R_{ext} = 1\text{ k}\Omega$	25	-	30	mA
		$V_O = 0.8\text{ V}$ ; IREF <sub>x</sub> = FFh; $R_{ext} = 1\text{ k}\Omega$	<sup>[3]</sup> 50	-	60	mA
$\Delta I_O$	output current variation	$V_{DD} = 3.0\text{ V}$ ; $T_{amb} = 25\text{ °C}$ ; $V_O = 0.8\text{ V}$ ; IREF <sub>x</sub> = 80h; $R_{ext} = 1\text{ k}\Omega$ ; guaranteed by design				
		between bits (different ICs, same channel)	<sup>[4]</sup> -	-	$\pm 6$	%
		between bits (2 channels, same IC)	<sup>[5]</sup> -	-	$\pm 4$	%
$V_{reg(drv)}$	driver regulation voltage	minimum regulation voltage; IREF <sub>x</sub> = FFh; $R_{ext} = 1\text{ k}\Omega$	0.8	1	20	V
$I_{L(off)}$	off-state leakage current	$V_O = 20\text{ V}$	-	-	1	$\mu\text{A}$
$V_{trip}$	trip voltage	short LED protection; Error flag will trip during verification test if $V_O \geq V_{trip}$ ; $R_{ext} = 1\text{ k}\Omega$	2.7	2.85	-	V

**Table 26. Static characteristics ...continued**

V<sub>DD</sub> = 3 V to 5.5 V; V<sub>SS</sub> = 0 V; T<sub>amb</sub> = -40 °C to +85 °C; unless otherwise specified.

Symbol	Parameter	Conditions	Min	Typ <sup>[1]</sup>	Max	Unit	
<b>OE input, RESET input</b>							
V <sub>IL</sub>	LOW-level input voltage		-0.5	-	+0.3V <sub>DD</sub>	V	
V <sub>IH</sub>	HIGH-level input voltage		0.7V <sub>DD</sub>	-	5.5	V	
I <sub>LI</sub>	input leakage current		-1	-	+1	μA	
C <sub>i</sub>	input capacitance		[3]	-	3.7	pF	
<b>Address inputs AD2, AD1, AD0</b>							
V <sub>I</sub>	input voltage	voltage on an input pin	-0.5	-	5.5	V	
I <sub>LI</sub>	input leakage current		-1	-	+1	μA	
C <sub>i</sub>	input capacitance		[3]	-	3.7	pF	
<b>Overtemperature protection</b>							
T <sub>th(otp)</sub>	overtemperature protection threshold temperature	rising	[3]	130	-	150	°C
		hysteresis	[3]	15	-	30	°C

- [1] Typical limits at V<sub>DD</sub> = 3.3 V, T<sub>amb</sub> = 25 °C.
- [2] V<sub>DD</sub> must be lowered to 1 V in order to reset part.
- [3] Value not tested in production, but guaranteed by design and characterization.
- [4] Part-to-part mismatch is calculated:

$$\Delta\% = \left( \frac{\left( \frac{I_{O(LED0)} + I_{O(LED1)} + \dots + I_{O(LED22)} + I_{O(LED23)}}{24} - \text{ideal output current} \right)}{\text{ideal output current}} \right) \times 100$$

where 'ideal output current' = 28.68 mA (R<sub>ext</sub> = 1 kΩ, IREFx = 80h).

- [5] Channel-to-channel mismatch is calculated:

$$\Delta\% = \left( \frac{I_{O(LEDn)} \text{ (where n = 0 to 23)}}{\left( \frac{I_{O(LED0)} + I_{O(LED1)} + \dots + I_{O(LED22)} + I_{O(LED23)}}{24} \right)} - 1 \right) \times 100$$

## 14. Dynamic characteristics

Table 27. Dynamic characteristics

Symbol	Parameter	Conditions	Standard-mode I <sup>2</sup> C-bus		Fast-mode I <sup>2</sup> C-bus		Fast-mode Plus I <sup>2</sup> C-bus		Unit
			Min	Max	Min	Max	Min	Max	
f <sub>SCL</sub>	SCL clock frequency		0	100	0	400	0	1000	kHz
t <sub>BUF</sub>	bus free time between a STOP and START condition		4.7	-	1.3	-	0.5	-	μs
t <sub>HD,STA</sub>	hold time (repeated) START condition		4.0	-	0.6	-	0.26	-	μs
t <sub>SU,STA</sub>	set-up time for a repeated START condition		4.7	-	0.6	-	0.26	-	μs
t <sub>SU,STO</sub>	set-up time for STOP condition		4.0	-	0.6	-	0.26	-	μs
t <sub>HD,DAT</sub>	data hold time		0	-	0	-	0	-	ns
t <sub>VD,ACK</sub>	data valid acknowledge time	[1]	0.3	3.45	0.1	0.9	0.05	0.45	μs
t <sub>VD,DAT</sub>	data valid time	[2]	0.3	3.45	0.1	0.9	0.05	0.45	μs
t <sub>SU,DAT</sub>	data set-up time		250	-	100	-	50	-	ns
t <sub>LOW</sub>	LOW period of the SCL clock		4.7	-	1.3	-	0.5	-	μs
t <sub>HIGH</sub>	HIGH period of the SCL clock		4.0	-	0.6	-	0.26	-	μs
t <sub>f</sub>	fall time of both SDA and SCL signals	[3][4]	-	300	20 + 0.1C <sub>b</sub> [5]	300	-	120	ns
t <sub>r</sub>	rise time of both SDA and SCL signals		-	1000	20 + 0.1C <sub>b</sub> [5]	300	-	120	ns
t <sub>SP</sub>	pulse width of spikes that must be suppressed by the input filter	[6]	-	50	-	50	-	50	ns
t <sub>w(rst)</sub>	reset pulse width		2.5	-	2.5	-	2.5	-	μs

[1] t<sub>VD,ACK</sub> = time for Acknowledgement signal from SCL LOW to SDA (out) LOW.

[2] t<sub>VD,DAT</sub> = minimum time for SDA data out to be valid following SCL LOW.

[3] A master device must internally provide a hold time of at least 300 ns for the SDA signal (refer to the V<sub>IL</sub> of the SCL signal) in order to bridge the undefined region of SCL's falling edge.

[4] The maximum t<sub>f</sub> for the SDA and SCL bus lines is specified at 300 ns. The maximum fall time (t<sub>f</sub>) for the SDA output stage is specified at 250 ns. This allows series protection resistors to be connected between the SDA and the SCL pins and the SDA/SCL bus lines without exceeding the maximum specified t<sub>f</sub>.

[5] C<sub>b</sub> = total capacitance of one bus line in pF.

[6] Input filters on the SDA and SCL inputs suppress noise spikes less than 50 ns.

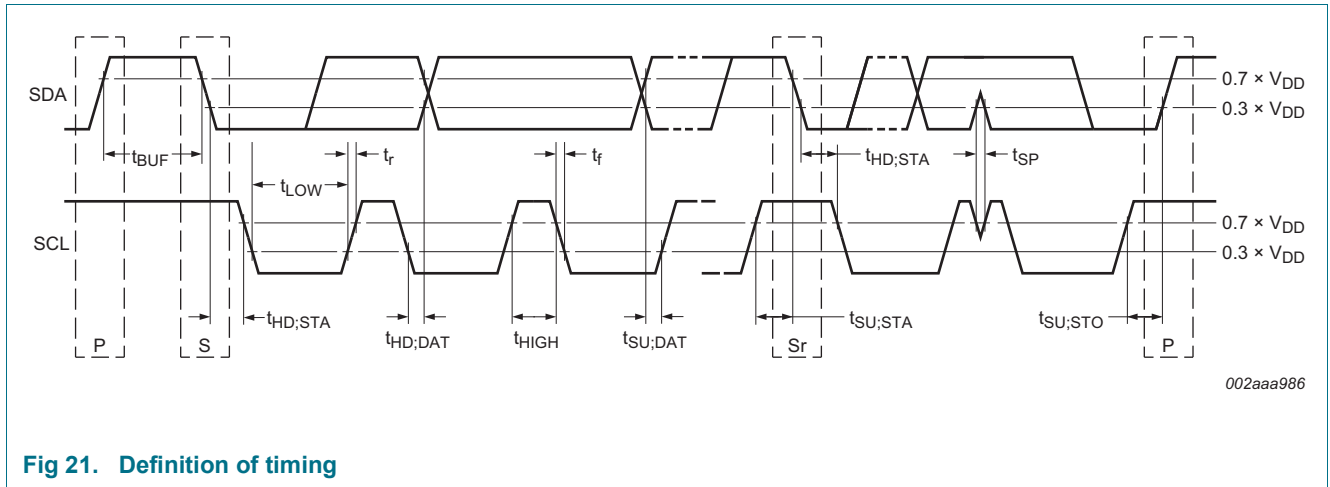

Fig 21. Definition of timing

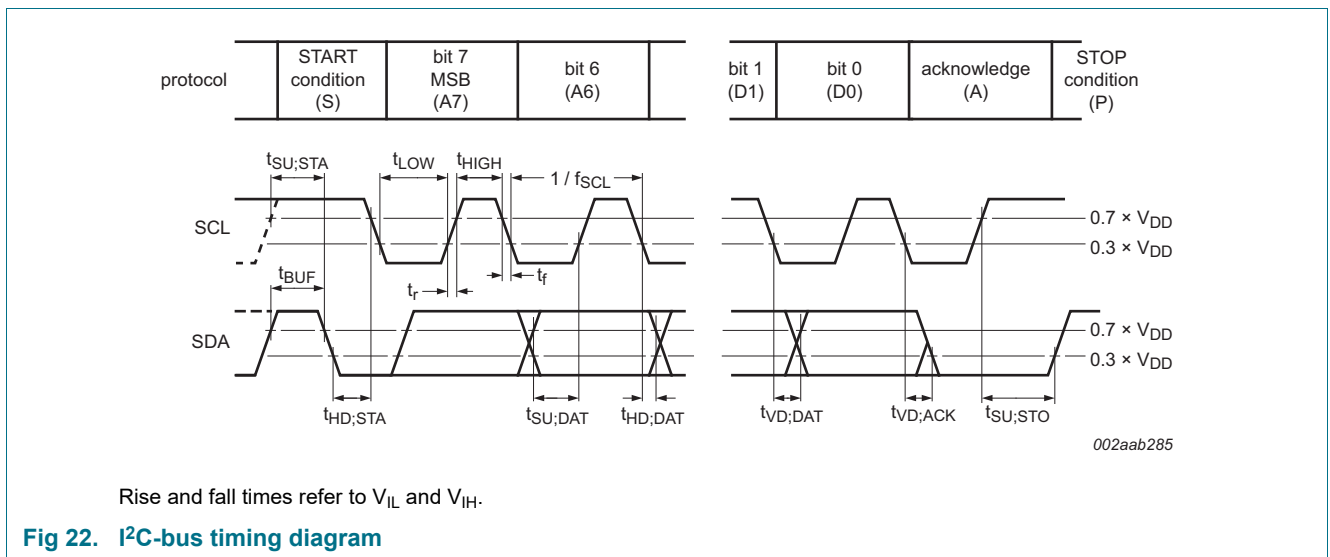

Fig 22. I<sup>2</sup>C-bus timing diagram

## 15. Test information

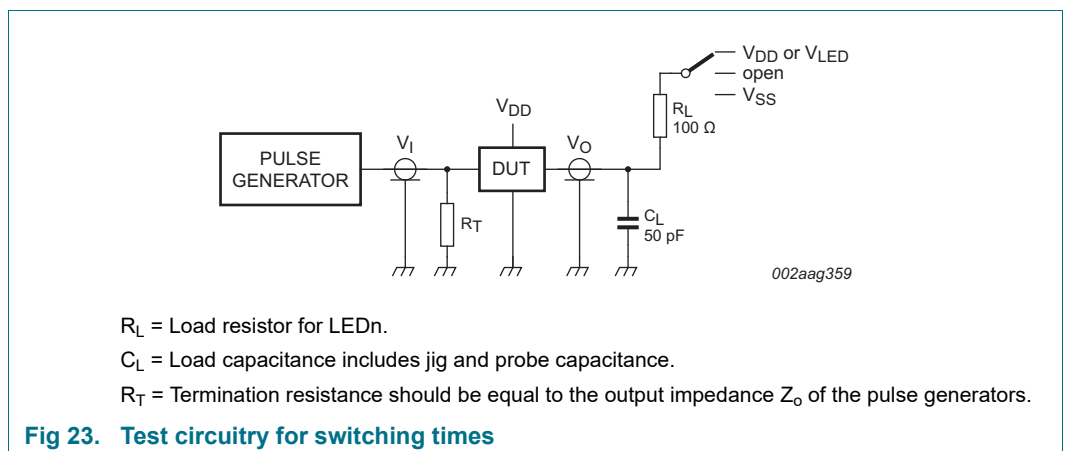

Fig 23. Test circuitry for switching times

16. Package outline

HTSSOP38: plastic thermal enhanced thin shrink small outline package; 38 leads; body with 4.4 mm; lead pitch 0.5 mm; exposed die pad

SOT1331-1

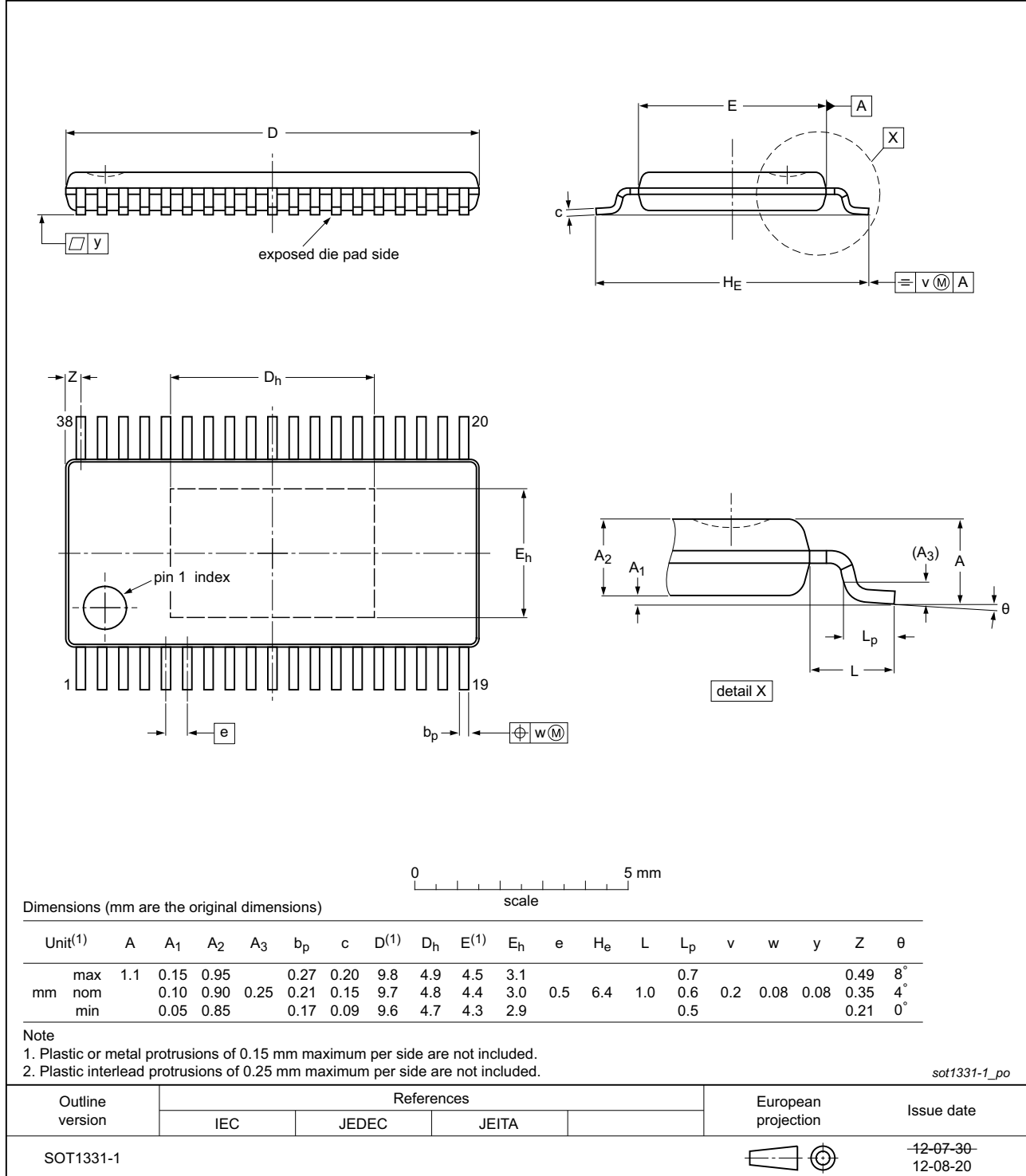

Fig 24. Package outline SOT1331-1 (HTSSOP38)

## 17. Handling information

---

All input and output pins are protected against ElectroStatic Discharge (ESD) under normal handling. When handling ensure that the appropriate precautions are taken as described in *JESD625-A* or equivalent standards.

## 18. Soldering of SMD packages

---

This text provides a very brief insight into a complex technology. A more in-depth account of soldering ICs can be found in Application Note *AN10365 "Surface mount reflow soldering description"*.

### 18.1 Introduction to soldering

Soldering is one of the most common methods through which packages are attached to Printed Circuit Boards (PCBs), to form electrical circuits. The soldered joint provides both the mechanical and the electrical connection. There is no single soldering method that is ideal for all IC packages. Wave soldering is often preferred when through-hole and Surface Mount Devices (SMDs) are mixed on one printed wiring board; however, it is not suitable for fine pitch SMDs. Reflow soldering is ideal for the small pitches and high densities that come with increased miniaturization.

### 18.2 Wave and reflow soldering

Wave soldering is a joining technology in which the joints are made by solder coming from a standing wave of liquid solder. The wave soldering process is suitable for the following:

- Through-hole components
- Leaded or leadless SMDs, which are glued to the surface of the printed circuit board

Not all SMDs can be wave soldered. Packages with solder balls, and some leadless packages which have solder lands underneath the body, cannot be wave soldered. Also, leaded SMDs with leads having a pitch smaller than ~0.6 mm cannot be wave soldered, due to an increased probability of bridging.

The reflow soldering process involves applying solder paste to a board, followed by component placement and exposure to a temperature profile. Leaded packages, packages with solder balls, and leadless packages are all reflow solderable.

Key characteristics in both wave and reflow soldering are:

- Board specifications, including the board finish, solder masks and vias
- Package footprints, including solder thieves and orientation
- The moisture sensitivity level of the packages
- Package placement
- Inspection and repair
- Lead-free soldering versus SnPb soldering

### 18.3 Wave soldering

Key characteristics in wave soldering are:

- Process issues, such as application of adhesive and flux, clinching of leads, board transport, the solder wave parameters, and the time during which components are exposed to the wave
- Solder bath specifications, including temperature and impurities

### 18.4 Reflow soldering

Key characteristics in reflow soldering are:

- Lead-free versus SnPb soldering; note that a lead-free reflow process usually leads to higher minimum peak temperatures (see [Figure 25](#)) than a SnPb process, thus reducing the process window
- Solder paste printing issues including smearing, release, and adjusting the process window for a mix of large and small components on one board
- Reflow temperature profile; this profile includes preheat, reflow (in which the board is heated to the peak temperature) and cooling down. It is imperative that the peak temperature is high enough for the solder to make reliable solder joints (a solder paste characteristic). In addition, the peak temperature must be low enough that the packages and/or boards are not damaged. The peak temperature of the package depends on package thickness and volume and is classified in accordance with [Table 28](#) and [29](#)

**Table 28. SnPb eutectic process (from J-STD-020D)**

Package thickness (mm)	Package reflow temperature (°C)	
	Volume (mm <sup>3</sup> )	
	< 350	≥ 350
< 2.5	235	220
≥ 2.5	220	220

**Table 29. Lead-free process (from J-STD-020D)**

Package thickness (mm)	Package reflow temperature (°C)		
	Volume (mm <sup>3</sup> )		
	< 350	350 to 2000	> 2000
< 1.6	260	260	260
1.6 to 2.5	260	250	245
> 2.5	250	245	245

Moisture sensitivity precautions, as indicated on the packing, must be respected at all times.

Studies have shown that small packages reach higher temperatures during reflow soldering, see [Figure 25](#).

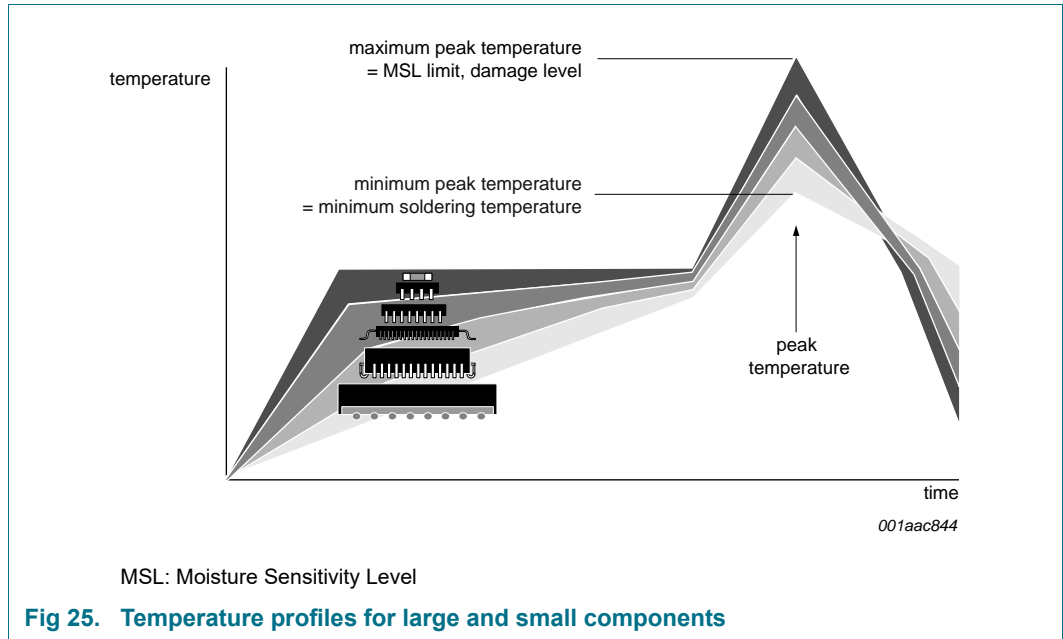

For further information on temperature profiles, refer to Application Note AN10365 “Surface mount reflow soldering description”.



### 19. Soldering: PCB footprints

Footprint information for reflow soldering of HTSSOP38 package

SOT1331-1

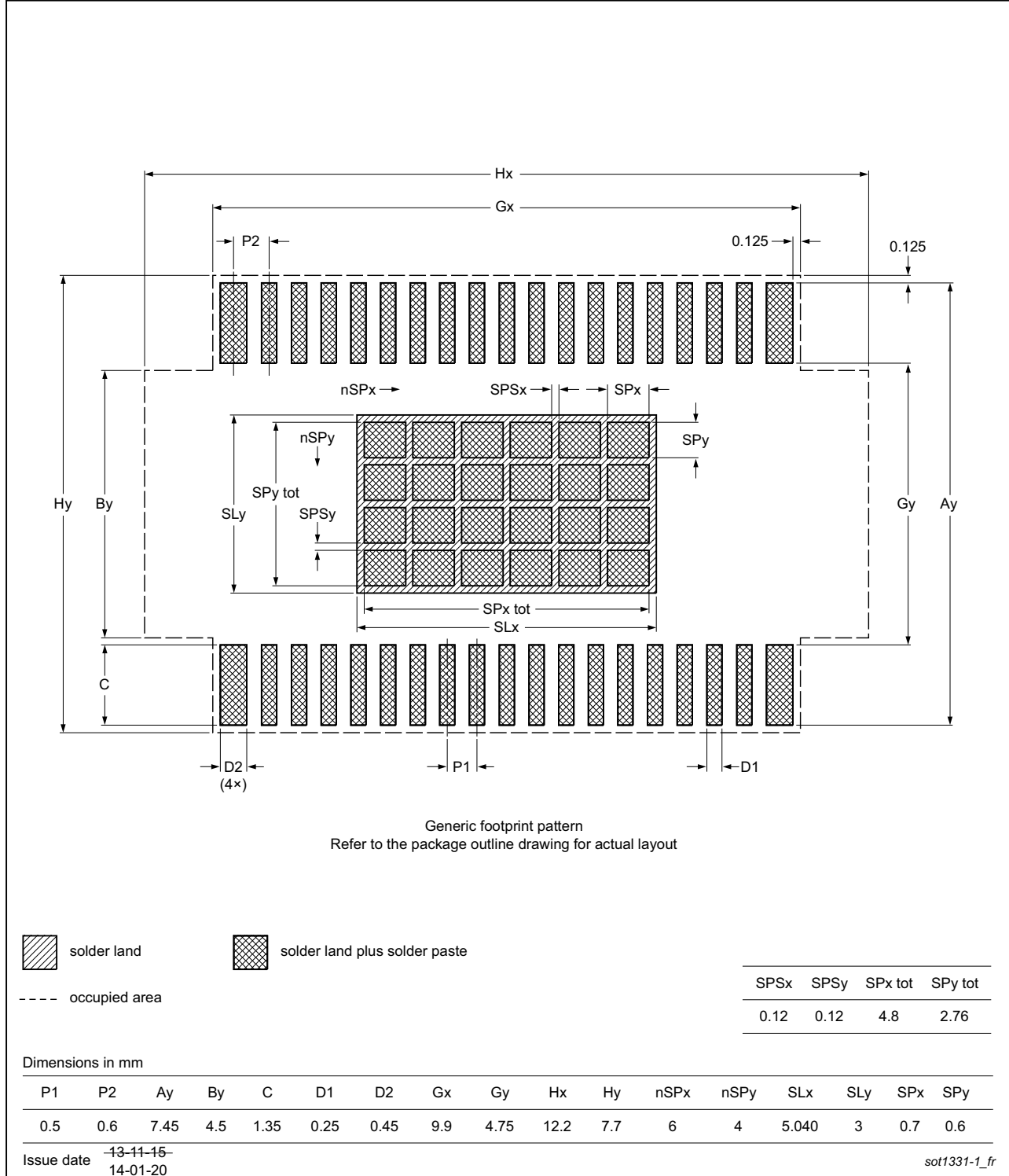

Fig 26. PCB footprint for SOT1331-1 (HTSSOP38); reflow soldering

## 20. Abbreviations

Table 30. Abbreviations

Acronym	Description
ACK	Acknowledge
CDM	Charged-Device Model
DUT	Device Under Test
ESD	ElectroStatic Discharge
FET	Field-Effect Transistor
HBM	Human Body Model
I <sup>2</sup> C-bus	Inter-Integrated Circuit bus
LED	Light Emitting Diode
LSB	Least Significant Bit
MSB	Most Significant Bit
NMOS	Negative-channel Metal-Oxide Semiconductor
PCB	Printed-Circuit Board
PMOS	Positive-channel Metal-Oxide Semiconductor
PWM	Pulse Width Modulation
RGB	Red/Green/Blue
RGBA	Red/Green/Blue/Amber
SMBus	System Management Bus

## 21. Revision history

Table 31. Revision history

Document ID	Release date	Data sheet status	Change notice	Supersedes
PCA9956B v.1.2	20200610	Product data sheet	202005012I	PCA9956B v.1.1
Modifications:	<ul style="list-style-type: none"> <li>• <a href="#">Section 2</a>, <a href="#">Section 7.3.13.1</a>, <a href="#">Section 7.3.14</a>: Added clarification regarding size of R<sub>ext</sub> at which the LED open/short detection no longer works</li> </ul>			
PCA9956B v.1.1	20151215	Product data sheet	-	PCA9956B v.1
Modifications:	<ul style="list-style-type: none"> <li>• <a href="#">Figure 1</a>: Removed 200 kΩ resistor</li> <li>• <a href="#">Table 3</a>: Updated description for pin 35</li> <li>• <a href="#">Figure 20</a>: Changed value for <math>\overline{\text{RESET}}</math> resistor from 1.1 kΩ to 10 kΩ; added note <a href="#">[3]</a>.</li> </ul>			
PCA9956B v.1	20150831	Product data sheet	-	-

## 22. Legal information

### 22.1 Data sheet status

Document status <sup>[1][2]</sup>	Product status <sup>[3]</sup>	Definition
Objective [short] data sheet	Development	This document contains data from the objective specification for product development.
Preliminary [short] data sheet	Qualification	This document contains data from the preliminary specification.
Product [short] data sheet	Production	This document contains the product specification.

[1] Please consult the most recently issued document before initiating or completing a design.

[2] The term 'short data sheet' is explained in section "Definitions".

[3] The product status of device(s) described in this document may have changed since this document was published and may differ in case of multiple devices. The latest product status information is available on the Internet at URL <http://www.nxp.com>.

### 22.2 Definitions

**Draft** — The document is a draft version only. The content is still under internal review and subject to formal approval, which may result in modifications or additions. NXP Semiconductors does not give any representations or warranties as to the accuracy or completeness of information included herein and shall have no liability for the consequences of use of such information.

**Short data sheet** — A short data sheet is an extract from a full data sheet with the same product type number(s) and title. A short data sheet is intended for quick reference only and should not be relied upon to contain detailed and full information. For detailed and full information see the relevant full data sheet, which is available on request via the local NXP Semiconductors sales office. In case of any inconsistency or conflict with the short data sheet, the full data sheet shall prevail.

**Product specification** — The information and data provided in a Product data sheet shall define the specification of the product as agreed between NXP Semiconductors and its customer, unless NXP Semiconductors and customer have explicitly agreed otherwise in writing. In no event however, shall an agreement be valid in which the NXP Semiconductors product is deemed to offer functions and qualities beyond those described in the Product data sheet.

### 22.3 Disclaimers

**Limited warranty and liability** — Information in this document is believed to be accurate and reliable. However, NXP Semiconductors does not give any representations or warranties, expressed or implied, as to the accuracy or completeness of such information and shall have no liability for the consequences of use of such information. NXP Semiconductors takes no responsibility for the content in this document if provided by an information source outside of NXP Semiconductors.

In no event shall NXP Semiconductors be liable for any indirect, incidental, punitive, special or consequential damages (including - without limitation - lost profits, lost savings, business interruption, costs related to the removal or replacement of any products or rework charges) whether or not such damages are based on tort (including negligence), warranty, breach of contract or any other legal theory.

Notwithstanding any damages that customer might incur for any reason whatsoever, NXP Semiconductors' aggregate and cumulative liability towards customer for the products described herein shall be limited in accordance with the *Terms and conditions of commercial sale* of NXP Semiconductors.

**Right to make changes** — NXP Semiconductors reserves the right to make changes to information published in this document, including without limitation specifications and product descriptions, at any time and without notice. This document supersedes and replaces all information supplied prior to the publication hereof.

**Suitability for use** — NXP Semiconductors products are not designed, authorized or warranted to be suitable for use in life support, life-critical or safety-critical systems or equipment, nor in applications where failure or malfunction of an NXP Semiconductors product can reasonably be expected to result in personal injury, death or severe property or environmental damage. NXP Semiconductors and its suppliers accept no liability for inclusion and/or use of NXP Semiconductors products in such equipment or applications and therefore such inclusion and/or use is at the customer's own risk.

**Applications** — Applications that are described herein for any of these products are for illustrative purposes only. NXP Semiconductors makes no representation or warranty that such applications will be suitable for the specified use without further testing or modification.

Customers are responsible for the design and operation of their applications and products using NXP Semiconductors products, and NXP Semiconductors accepts no liability for any assistance with applications or customer product design. It is customer's sole responsibility to determine whether the NXP Semiconductors product is suitable and fit for the customer's applications and products planned, as well as for the planned application and use of customer's third party customer(s). Customers should provide appropriate design and operating safeguards to minimize the risks associated with their applications and products.

NXP Semiconductors does not accept any liability related to any default, damage, costs or problem which is based on any weakness or default in the customer's applications or products, or the application or use by customer's third party customer(s). Customer is responsible for doing all necessary testing for the customer's applications and products using NXP Semiconductors products in order to avoid a default of the applications and the products or of the application or use by customer's third party customer(s). NXP does not accept any liability in this respect.

**Limiting values** — Stress above one or more limiting values (as defined in the Absolute Maximum Ratings System of IEC 60134) will cause permanent damage to the device. Limiting values are stress ratings only and (proper) operation of the device at these or any other conditions above those given in the Recommended operating conditions section (if present) or the Characteristics sections of this document is not warranted. Constant or repeated exposure to limiting values will permanently and irreversibly affect the quality and reliability of the device.

**Terms and conditions of commercial sale** — NXP Semiconductors products are sold subject to the general terms and conditions of commercial sale, as published at <http://www.nxp.com/profile/terms>, unless otherwise agreed in a valid written individual agreement. In case an individual agreement is concluded only the terms and conditions of the respective agreement shall apply. NXP Semiconductors hereby expressly objects to applying the customer's general terms and conditions with regard to the purchase of NXP Semiconductors products by customer.

**No offer to sell or license** — Nothing in this document may be interpreted or construed as an offer to sell products that is open for acceptance or the grant, conveyance or implication of any license under any copyrights, patents or other industrial or intellectual property rights.

**Export control** — This document as well as the item(s) described herein may be subject to export control regulations. Export might require a prior authorization from competent authorities.

**Non-automotive qualified products** — Unless this data sheet expressly states that this specific NXP Semiconductors product is automotive qualified, the product is not suitable for automotive use. It is neither qualified nor tested in accordance with automotive testing or application requirements. NXP Semiconductors accepts no liability for inclusion and/or use of non-automotive qualified products in automotive equipment or applications.

In the event that customer uses the product for design-in and use in automotive applications to automotive specifications and standards, customer (a) shall use the product without NXP Semiconductors' warranty of the product for such automotive applications, use and specifications, and (b) whenever customer uses the product for automotive applications beyond NXP Semiconductors' specifications such use shall be solely at customer's

own risk, and (c) customer fully indemnifies NXP Semiconductors for any liability, damages or failed product claims resulting from customer design and use of the product for automotive applications beyond NXP Semiconductors' standard warranty and NXP Semiconductors' product specifications.

**Translations** — A non-English (translated) version of a document is for reference only. The English version shall prevail in case of any discrepancy between the translated and English versions.

## 22.4 Trademarks

Notice: All referenced brands, product names, service names and trademarks are the property of their respective owners.

**I<sup>2</sup>C-bus** — logo is a trademark of NXP B.V.

## 23. Contact information

---

For more information, please visit: <http://www.nxp.com>

For sales office addresses, please send an email to: [salesaddresses@nxp.com](mailto:salesaddresses@nxp.com)

24. Contents

<b>1</b>	<b>General description</b> . . . . .	<b>1</b>	<b>8</b>	<b>Characteristics of the I<sup>2</sup>C-bus</b> . . . . .	<b>31</b>
<b>2</b>	<b>Features and benefits</b> . . . . .	<b>2</b>	8.1	Bit transfer . . . . .	31
<b>3</b>	<b>Applications</b> . . . . .	<b>3</b>	8.1.1	START and STOP conditions . . . . .	31
<b>4</b>	<b>Ordering information</b> . . . . .	<b>3</b>	8.2	System configuration . . . . .	31
4.1	Ordering options . . . . .	3	8.3	Acknowledge . . . . .	32
<b>5</b>	<b>Block diagram</b> . . . . .	<b>4</b>	<b>9</b>	<b>Bus transactions</b> . . . . .	<b>33</b>
<b>6</b>	<b>Pinning information</b> . . . . .	<b>5</b>	<b>10</b>	<b>Application design-in information</b> . . . . .	<b>37</b>
6.1	Pinning . . . . .	5	10.1	Thermal considerations . . . . .	38
6.2	Pin description . . . . .	6	<b>11</b>	<b>Limiting values</b> . . . . .	<b>40</b>
<b>7</b>	<b>Functional description</b> . . . . .	<b>7</b>	<b>12</b>	<b>Thermal characteristics</b> . . . . .	<b>40</b>
7.1	Device addresses . . . . .	7	<b>13</b>	<b>Static characteristics</b> . . . . .	<b>41</b>
7.1.1	Regular I <sup>2</sup> C-bus slave address . . . . .	7	<b>14</b>	<b>Dynamic characteristics</b> . . . . .	<b>43</b>
7.1.2	LED All Call I <sup>2</sup> C-bus address . . . . .	11	<b>15</b>	<b>Test information</b> . . . . .	<b>44</b>
7.1.3	LED Sub Call I <sup>2</sup> C-bus addresses . . . . .	11	<b>16</b>	<b>Package outline</b> . . . . .	<b>45</b>
7.2	Control register . . . . .	12	<b>17</b>	<b>Handling information</b> . . . . .	<b>46</b>
7.3	Register definitions . . . . .	13	<b>18</b>	<b>Soldering of SMD packages</b> . . . . .	<b>46</b>
7.3.1	MODE1 — Mode register 1 . . . . .	16	18.1	Introduction to soldering . . . . .	46
7.3.2	MODE2 — Mode register 2 . . . . .	16	18.2	Wave and reflow soldering . . . . .	46
7.3.3	LEDOUT0 to LEDOUT5, LED driver output state . . . . .	17	18.3	Wave soldering . . . . .	46
7.3.4	GRPPWM, group duty cycle control . . . . .	18	18.4	Reflow soldering . . . . .	47
7.3.5	GRPFREQ, group frequency . . . . .	18	<b>19</b>	<b>Soldering: PCB footprints</b> . . . . .	<b>49</b>
7.3.6	PWM0 to PWM23, individual brightness control . . . . .	19	<b>20</b>	<b>Abbreviations</b> . . . . .	<b>50</b>
7.3.7	IREF0 to IREF23, LED output current value registers . . . . .	20	<b>21</b>	<b>Revision history</b> . . . . .	<b>50</b>
7.3.8	OFFSET — LEDn output delay offset register . . . . .	20	<b>22</b>	<b>Legal information</b> . . . . .	<b>51</b>
7.3.9	LED Sub Call I <sup>2</sup> C-bus addresses for PCA9956B . . . . .	22	22.1	Data sheet status . . . . .	51
7.3.10	ALLCALLADR, LED All Call I <sup>2</sup> C-bus address . . . . .	22	22.2	Definitions . . . . .	51
7.3.11	PWMALL — brightness control for all LEDn outputs . . . . .	23	22.3	Disclaimers . . . . .	51
7.3.12	IREFALL register: output current value for all LED outputs . . . . .	23	22.4	Trademarks . . . . .	52
7.3.13	LED driver constant current outputs . . . . .	23	<b>23</b>	<b>Contact information</b> . . . . .	<b>52</b>
7.3.13.1	Adjusting output current . . . . .	23	<b>24</b>	<b>Contents</b> . . . . .	<b>53</b>
7.3.14	LED error detection . . . . .	25			
7.3.14.1	Open-circuit detection principle . . . . .	26			
7.3.14.2	Short-circuit detection principle . . . . .	27			
7.3.15	Overtemperature protection . . . . .	27			
7.4	Active LOW output enable input . . . . .	28			
7.5	Power-on reset . . . . .	28			
7.6	Hardware reset recovery . . . . .	28			
7.7	Software reset . . . . .	29			
7.8	Individual brightness control with group dimming/blinking . . . . .	30			

Please be aware that important notices concerning this document and the product(s) described herein, have been included in section 'Legal information'.

© NXP Semiconductors B.V. 2020. All rights reserved.

For more information, please visit: <http://www.nxp.com>  
 For sales office addresses, please send an email to: [salesaddresses@nxp.com](mailto:salesaddresses@nxp.com)

Date of release: 10 June 2020  
 Document identifier: PCA9956B