



PCA9538A

Low-voltage 8-bit I²C-bus I/O port with interrupt and reset

Rev. 1 — 28 September 2012

Product data sheet

1. General description

The PCA9538A is a low-voltage 8-bit General Purpose Input/Output (GPIO) expander with interrupt and reset for I²C-bus/SMBus applications. NXP I/O expanders provide a simple solution when additional I/Os are needed while keeping interconnections to a minimum, for example, in ACPI power switches, sensors, push buttons, LEDs, fan control, etc.

In addition to providing a flexible set of GPIOs, the wide V_{DD} range of 1.65 V to 5.5 V allows the PCA9538A to interface with next-generation microprocessors and microcontrollers where supply levels are dropping down to conserve power.

The PCA9538A contains the PCA9538A register set of four 8-bit Configuration, Input, Output, and Polarity Inversion registers.

The PCA9538A is a pin-to-pin replacement for the PCA9538 and other industry-standard devices. A more fully functional device, the PCAL9538A, is available with Agile I/O features. See the respective data sheet for more details.

The PCA9538A open-drain interrupt (\overline{INT}) output is activated when any input state differs from its corresponding Input Port register state and is used to indicate to the system master that an input state has changed.

\overline{INT} can be connected to the interrupt input of a microcontroller. By sending an interrupt signal on this line, the remote I/O can inform the microcontroller if there is incoming data on its ports without having to communicate via the I²C-bus. Thus, the PCA9538A can remain a simple slave device.

The device outputs have 25 mA sink capabilities for directly driving LEDs while consuming low device current.

The power-on reset sets the registers to their default values and initializes the device state machine. In the PCA9538A, the \overline{RESET} pin causes the same reset/default I/O input configuration to occur without de-powering the device, holding the registers and I²C-bus state machine in their default state until the \overline{RESET} input is once again HIGH. This input requires a pull-up to V_{DD} .

Two hardware pins (A0, A1) select the fixed I²C-bus address and allow up to four devices to share the same I²C-bus/SMBus.



2. Features and benefits

- I²C-bus to parallel port expander
- Operating power supply voltage range of 1.65 V to 5.5 V
- Low standby current consumption:
 - ◆ 1.5 μ A (typical at 5 V V_{DD})
 - ◆ 1.0 μ A (typical at 3.3 V V_{DD})
- Schmitt-trigger action allows slow input transition and better switching noise immunity at the SCL and SDA inputs
 - ◆ $V_{hys} = 0.10 \times V_{DD}$ (typical)
- 5 V tolerant I/Os
- Active LOW reset input (\overline{RESET})
- Open-drain active LOW interrupt output (\overline{INT})
- 400 kHz Fast-mode I²C-bus
- Internal power-on reset
- Power-up with all channels configured as inputs
- No glitch on power-up
- Latched outputs with 25 mA drive maximum capability for directly driving LEDs
- Latch-up performance exceeds 100 mA per JESD78, Class II
- ESD protection exceeds JESD22
 - ◆ 2000 V Human Body Model (A114-A)
 - ◆ 1000 V Charged-Device Model (C101)
- Packages offered: TSSOP16 and HVQFN16

3. Ordering information

Table 1. Ordering information

| Type number | Topside mark | Package | | |
|-------------|--------------|---------|--|----------|
| | | Name | Description | Version |
| PCA9538ABS | P3A | HVQFN16 | plastic thermal enhanced very thin quad flat package; no leads; 16 terminals; body 3 × 3 × 0.85 mm | SOT758-1 |
| PCA9538APW | PA9538A | TSSOP16 | plastic thin shrink small outline package; 16 leads; body width 4.4 mm | SOT403-1 |

3.1 Ordering options

Table 2. Ordering options

| Type number | Orderable part number | Package | Packing method | Minimum order quantity | Temperature |
|-------------|-----------------------|---------|---------------------------------|------------------------|--|
| PCA9538ABS | PCA9538ABSHP | HVQFN16 | Reel pack, SMD, 13-inch, Turned | 6000 | $T_{amb} = -40\text{ }^{\circ}\text{C to }+85\text{ }^{\circ}\text{C}$ |
| PCA9538APW | PCA9538APWJ | TSSOP16 | Reel pack, SMD, 13-inch | 2500 | $T_{amb} = -40\text{ }^{\circ}\text{C to }+85\text{ }^{\circ}\text{C}$ |

4. Block diagram

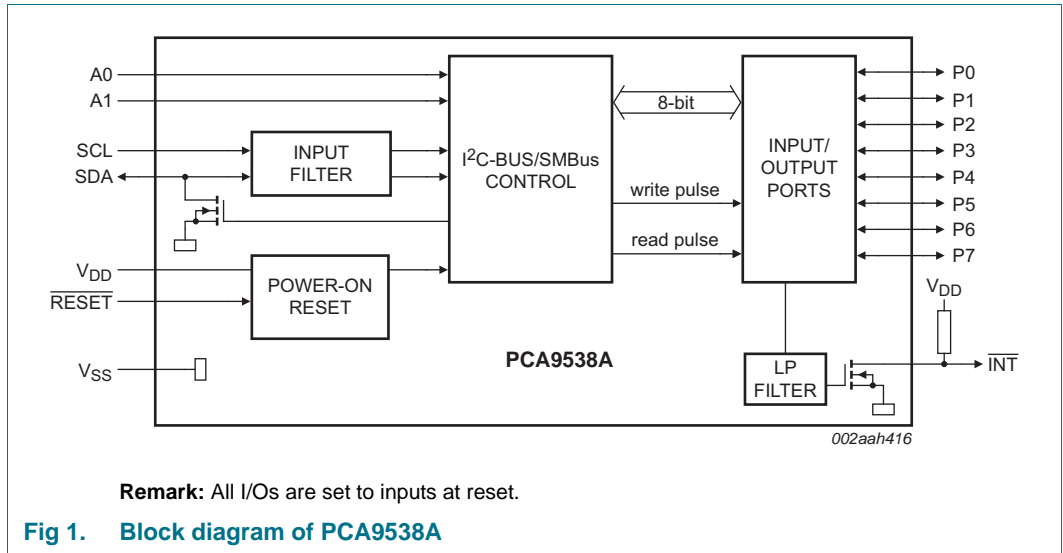
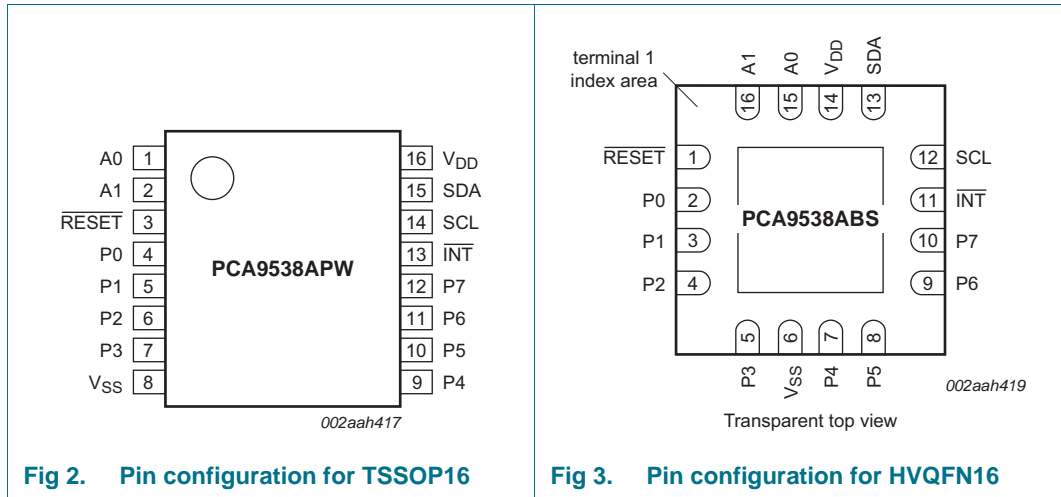

Fig 1. Block diagram of PCA9538A

5. Pinning information

5.1 Pinning



5.2 Pin description

Table 3. Pin description

| Symbol | Pin | | Description |
|-------------------|---------|------------------|-------------------------------|
| | TSSOP16 | HVQFN16 | |
| A0 | 1 | 15 | address input 0 |
| A1 | 2 | 16 | address input 1 |
| RESET | 3 | 1 | active LOW reset input |
| P0 ^[1] | 4 | 2 | Port P input/output 0 |
| P1 ^[1] | 5 | 3 | Port P input/output 1 |
| P2 ^[1] | 6 | 4 | Port P input/output 2 |
| P3 ^[1] | 7 | 5 | Port P input/output 3 |
| V _{SS} | 8 | 6 ^[2] | supply ground |
| P4 ^[1] | 9 | 7 | Port P input/output 4 |
| P5 ^[1] | 10 | 8 | Port P input/output 5 |
| P6 ^[1] | 11 | 9 | Port P input/output 6 |
| P7 ^[1] | 12 | 10 | Port P input/output 7 |
| INT | 13 | 11 | interrupt output (open-drain) |
| SCL | 14 | 12 | serial clock line |
| SDA | 15 | 13 | serial data line |
| V _{DD} | 16 | 14 | supply voltage |

[1] All I/O are configured as input at power-on.

[2] HVQFN16 package die supply ground is connected to both the V_{SS} pin and the exposed center pad. The V_{SS} pin must be connected to supply ground for proper device operation. For enhanced thermal, electrical, and board-level performance, the exposed pad needs to be soldered to the board using a corresponding thermal pad on the board, and for proper heat conduction through the board thermal vias need to be incorporated in the printed-circuit board in the thermal pad region.

6. Functional description

Refer to [Figure 1 “Block diagram of PCA9538A”](#).

6.1 Device address

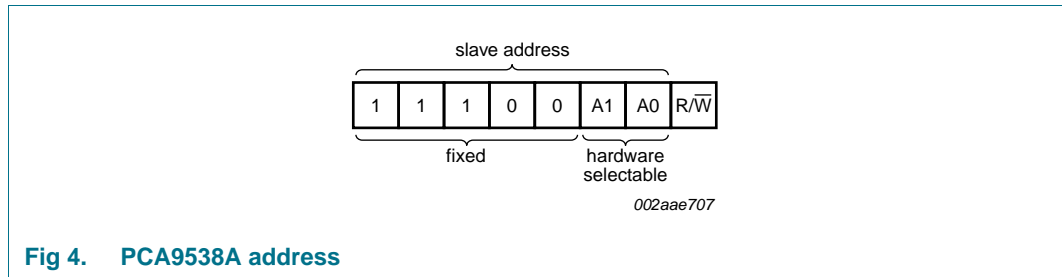

A1 and A0 are the hardware address package pins and are held to either HIGH (logic 1) or LOW (logic 0) to assign one of the four possible slave addresses. The last bit of the slave address ($\overline{R/W}$) defines the operation (read or write) to be performed. A HIGH (logic 1) selects a read operation, while a LOW (logic 0) selects a write operation.

6.2 Pointer register and command byte

Following the successful acknowledgement of the address byte, the bus master sends a command byte, which is stored in the Pointer register in the PCA9538A. Two bits of this data byte state the operation (read or write) and the internal registers (Input, Output, Polarity Inversion, or Configuration) that will be affected. Bit 6 in conjunction with the lower three bits of the Command byte are used to point to the extended features of the device (Agile I/O). This register is write only.

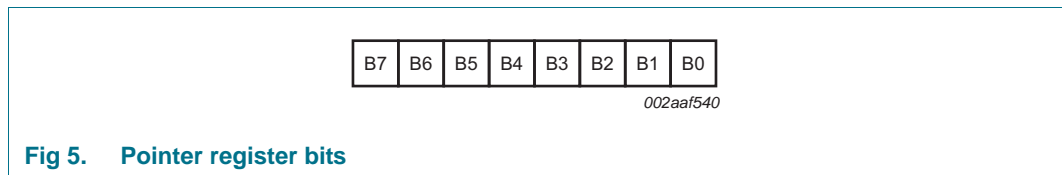

Table 4. Command byte

| Pointer register bits | | | | | | | | Command byte (hexadecimal) | Register | Protocol | Power-up default |
|-----------------------|----|----|----|----|----|----|----|----------------------------|--------------------|-----------------|--------------------------|
| B7 | B6 | B5 | B4 | B3 | B2 | B1 | B0 | | | | |
| 0 | 0 | 0 | 0 | 0 | 0 | 0 | 0 | 00h | Input port | read byte | xxxx xxxx ^[1] |
| 0 | 0 | 0 | 0 | 0 | 0 | 0 | 1 | 01h | Output port | read/write byte | 1111 1111 |
| 0 | 0 | 0 | 0 | 0 | 0 | 1 | 0 | 02h | Polarity Inversion | read/write byte | 0000 0000 |
| 0 | 0 | 0 | 0 | 0 | 0 | 1 | 1 | 03h | Configuration | read/write byte | 1111 1111 |

[1] Undefined.

6.3 Interface definition

Table 5. Interface definition

| Byte | Bit | | | | | | | |
|------------------------------------|---------|----|----|----|----|----|----|---------|
| | 7 (MSB) | 6 | 5 | 4 | 3 | 2 | 1 | 0 (LSB) |
| I ² C-bus slave address | H | H | H | L | L | A1 | A0 | R/W |
| I/O data bus | P7 | P6 | P5 | P4 | P3 | P2 | P1 | P0 |

6.4 Register descriptions

6.4.1 Input port register (00h)

The Input port register (register 0) reflects the incoming logic levels of the pins, regardless of whether the pin is defined as an input or an output by the Configuration register. The Input port register is read only; writes to this register have no effect. The default value 'X' is determined by the externally applied logic level. An Input port register read operation is performed as described in [Section 7.2 "Read commands"](#).

Table 6. Input port register (address 00h)

| Bit | 7 | 6 | 5 | 4 | 3 | 2 | 1 | 0 |
|---------|----|----|----|----|----|----|----|----|
| Symbol | I7 | I6 | I5 | I4 | I3 | I2 | I1 | I0 |
| Default | X | X | X | X | X | X | X | X |

6.4.2 Output port register (01h)

The Output port register (register 1) shows the outgoing logic levels of the pins defined as outputs by the Configuration register. Bit values in these registers have no effect on pins defined as inputs. In turn, reads from this register reflect the value that was written to this register, **not** the actual pin value.

Table 7. Output port register (address 01h)

| Bit | 7 | 6 | 5 | 4 | 3 | 2 | 1 | 0 |
|---------|----|----|----|----|----|----|----|----|
| Symbol | O7 | O6 | O5 | O4 | O3 | O2 | O1 | O0 |
| Default | 1 | 1 | 1 | 1 | 1 | 1 | 1 | 1 |

6.4.3 Polarity inversion register (02h)

The Polarity inversion register (register 2) allows polarity inversion of pins defined as inputs by the Configuration register. If a bit in this register is set (written with '1'), the corresponding port pin's polarity is inverted. If a bit in this register is cleared (written with a '0'), the corresponding port pin's original polarity is retained.

Table 8. Polarity inversion register (address 02h)

| Bit | 7 | 6 | 5 | 4 | 3 | 2 | 1 | 0 |
|---------|----|----|----|----|----|----|----|----|
| Symbol | N7 | N6 | N5 | N4 | N3 | N2 | N1 | N0 |
| Default | 0 | 0 | 0 | 0 | 0 | 0 | 0 | 0 |

6.4.4 Configuration register (03h)

The Configuration register (register 3) configures the direction of the I/O pins. If a bit in this register is set to 1, the corresponding port pin is enabled as a high-impedance input. If a bit in this register is cleared to 0, the corresponding port pin is enabled as an output.

Table 9. Configuration register (address 03h)

| Bit | 7 | 6 | 5 | 4 | 3 | 2 | 1 | 0 |
|---------|----|----|----|----|----|----|----|----|
| Symbol | C7 | C6 | C5 | C4 | C3 | C2 | C1 | C0 |
| Default | 1 | 1 | 1 | 1 | 1 | 1 | 1 | 1 |

6.5 I/O port

When an I/O is configured as an input, FETs Q1 and Q2 are off, which creates a high-impedance input. The input voltage may be raised above V_{DD} to a maximum of 5.5 V.

If the I/O is configured as an output, Q1 or Q2 is enabled, depending on the state of the Output port register. In this case, there are low-impedance paths between the I/O pin and either V_{DD} or V_{SS}. The external voltage applied to this I/O pin should not exceed the recommended levels for proper operation.

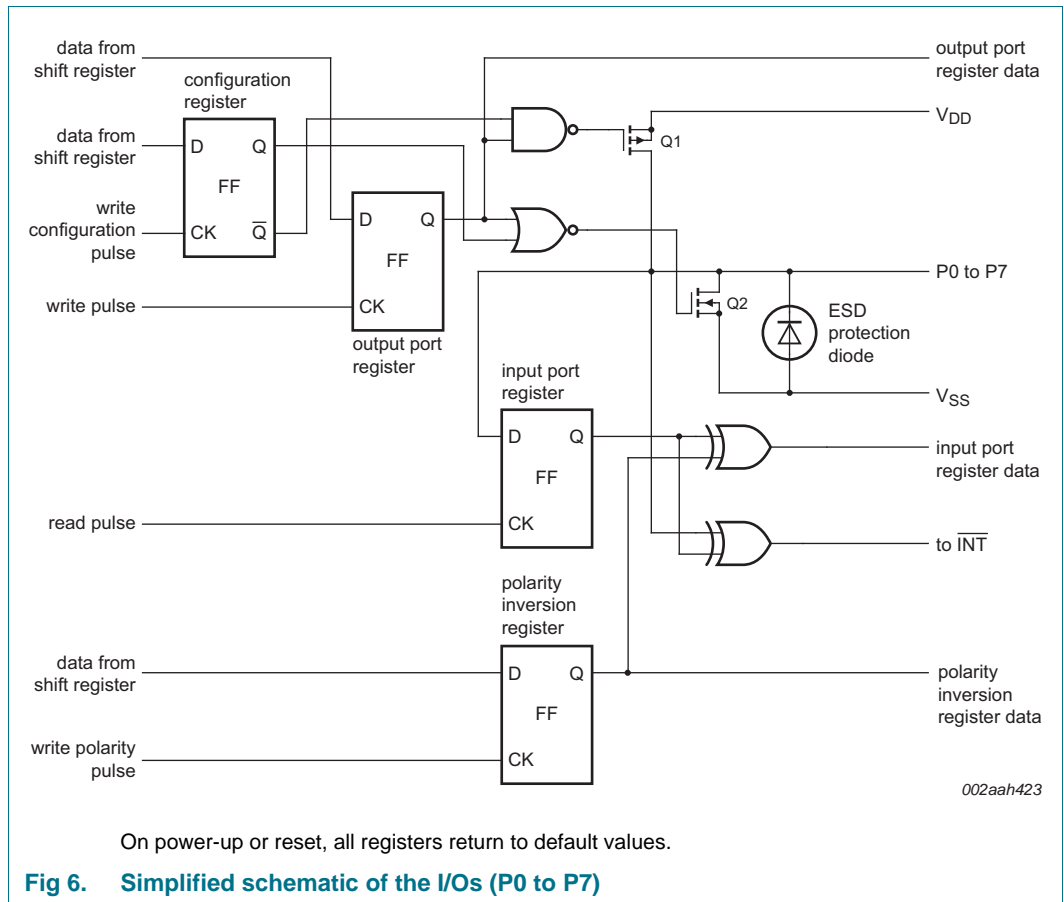

6.6 Power-on reset

When power (from 0 V) is applied to V_{DD} , an internal power-on reset holds the PCA9538A in a reset condition until V_{DD} has reached V_{POR} . At that time, the reset condition is released and the PCA9538A registers and I²C-bus/SMBus state machine initialize to their default states. After that, V_{DD} must be lowered to below V_{PORF} and back up to the operating voltage for a power-reset cycle. See [Section 8.3 “Power-on reset requirements”](#).

6.7 Reset input ($\overline{\text{RESET}}$)

The $\overline{\text{RESET}}$ input can be asserted to initialize the system while keeping the V_{DD} at its operating level. A reset can be accomplished by holding the $\overline{\text{RESET}}$ pin LOW for a minimum of $t_{w(\text{rst})}$. The PCA9538A registers and I²C-bus/SMBus state machine are changed to their default state once $\overline{\text{RESET}}$ is LOW (0). When $\overline{\text{RESET}}$ is HIGH (1), the I/O levels at the P port can be changed externally or through the master. This input requires a pull-up resistor to V_{DD} if no active connection is used.

6.8 Interrupt output ($\overline{\text{INT}}$)

An interrupt is generated by any rising or falling edge of the port inputs in the Input mode. After time $t_{v(\text{INT})}$, the signal $\overline{\text{INT}}$ is valid. Resetting the interrupt circuit is achieved when data on the port is changed to the original setting or when data is read from the port that generated the interrupt (see [Figure 10](#)). Resetting occurs in the Read mode at the acknowledge (ACK) or not acknowledge (NACK) bit after the rising edge of the SCL signal. Interrupts that occur during the ACK or NACK clock pulse can be lost (or be very short) due to the resetting of the interrupt during this pulse. Each change of the I/Os after resetting is detected and is transmitted as $\overline{\text{INT}}$.

A pin configured as an output cannot cause an interrupt. Changing an I/O from an output to an input may cause a false interrupt to occur, if the state of the pin does not match the contents of the Input port register.

The $\overline{\text{INT}}$ output has an open-drain structure and requires a pull-up resistor to V_{DD} . $\overline{\text{INT}}$ should be connected to the voltage source of the device that requires the interrupt information. When using the input latch feature, the input pin state is latched. The interrupt is reset only when data is read from the port that generated the interrupt. The reset occurs in the Read mode at the acknowledge (ACK) or not acknowledge (NACK) bit after the rising edge of the SCL signal.

7. Bus transactions

The PCA9538A is an I²C-bus slave device. Data is exchanged between the master and PCA9538A through write and read commands using I²C-bus. The two communication lines are a serial data line (SDA) and a serial clock line (SCL). Both lines must be connected to a positive supply via a pull-up resistor when connected to the output stages of a device. Data transfer may be initiated only when the bus is not busy.

7.1 Write commands

Data is transmitted to the PCA9538A by sending the device address and setting the Least Significant Bit (LSB) to a logic 0 (see [Figure 4](#) for device address). The command byte is sent after the address and determines which register receives the data that follows the command byte. There is no limitation on the number of data bytes sent in one write transmission.

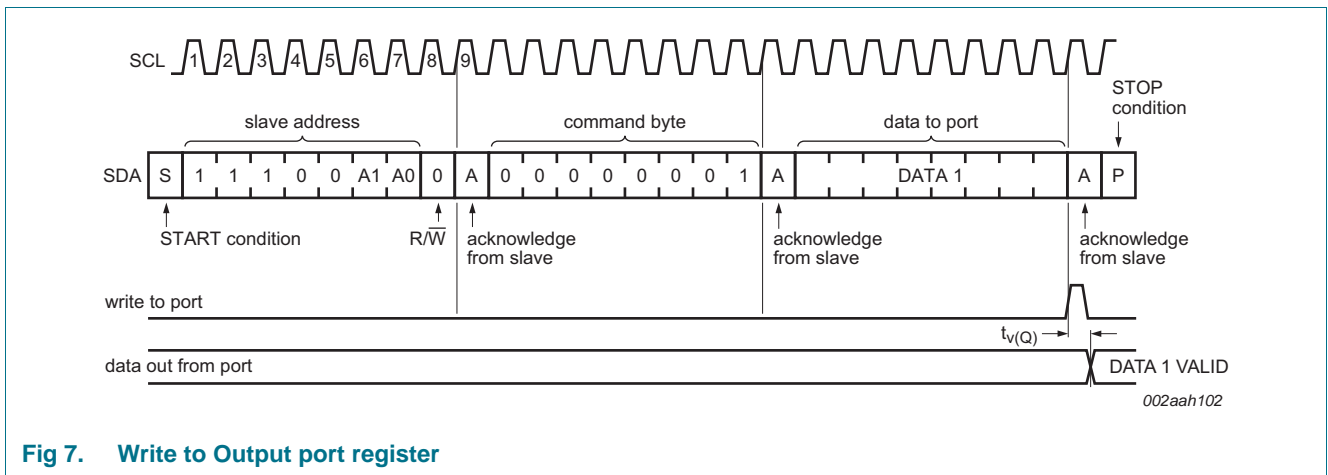

Fig 7. Write to Output port register

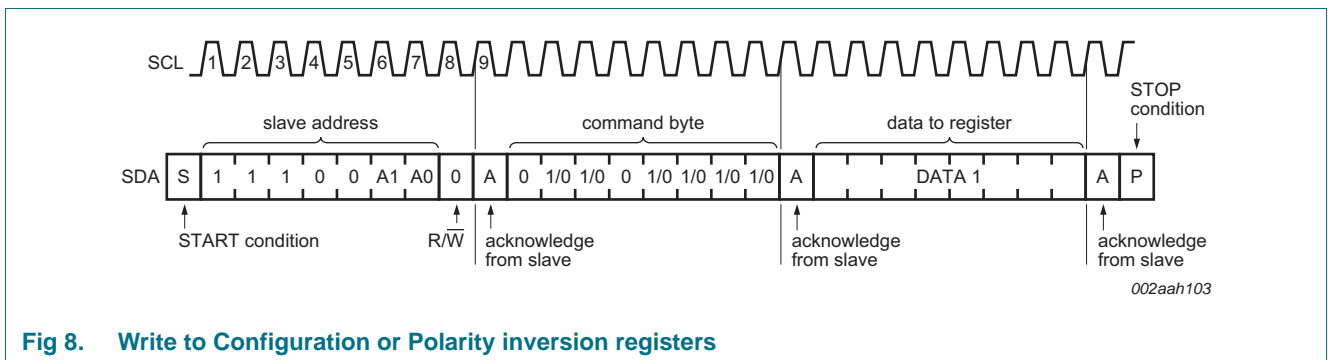

Fig 8. Write to Configuration or Polarity inversion registers

7.2 Read commands

To read data from the PCA9538A, the bus master must first send the PCA9538A address with the least significant bit set to a logic 0 (see [Figure 4](#) for device address). The command byte is sent after the address and determines which register is to be accessed.

After a restart the device address is sent again, but this time the LSB is set to a logic 1. Data from the register defined by the command byte then is sent by the PCA9538A (see [Figure 9](#) and [Figure 10](#)).

Data is clocked into the register on the rising edge of the ACK clock pulse. There is no limit on the number of data bytes received in one read transmission, but on the final byte received the bus master must not acknowledge the data.

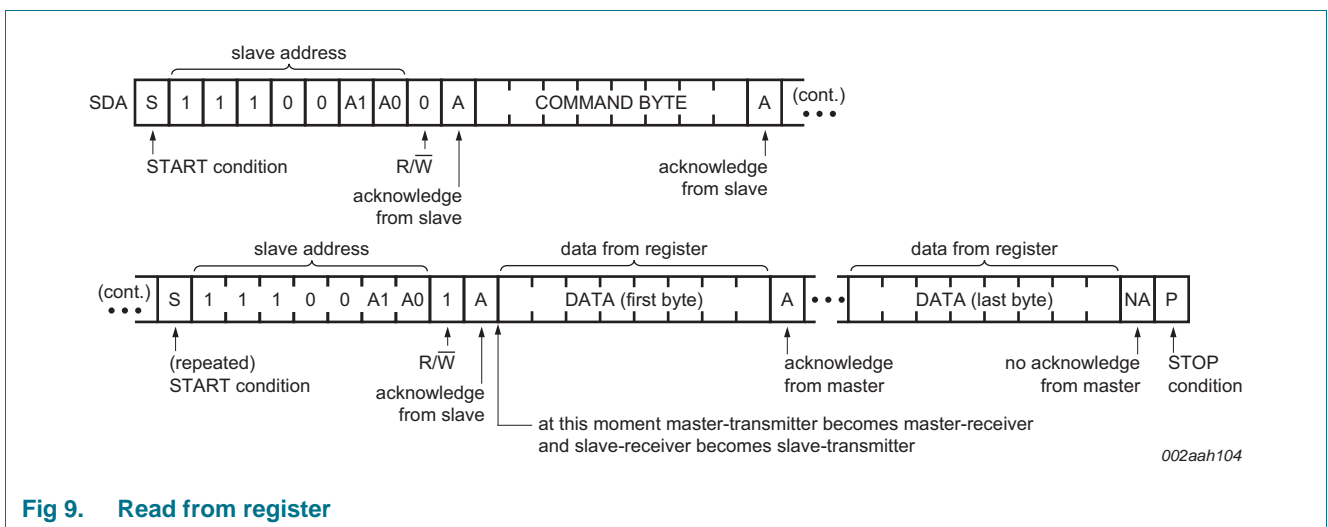
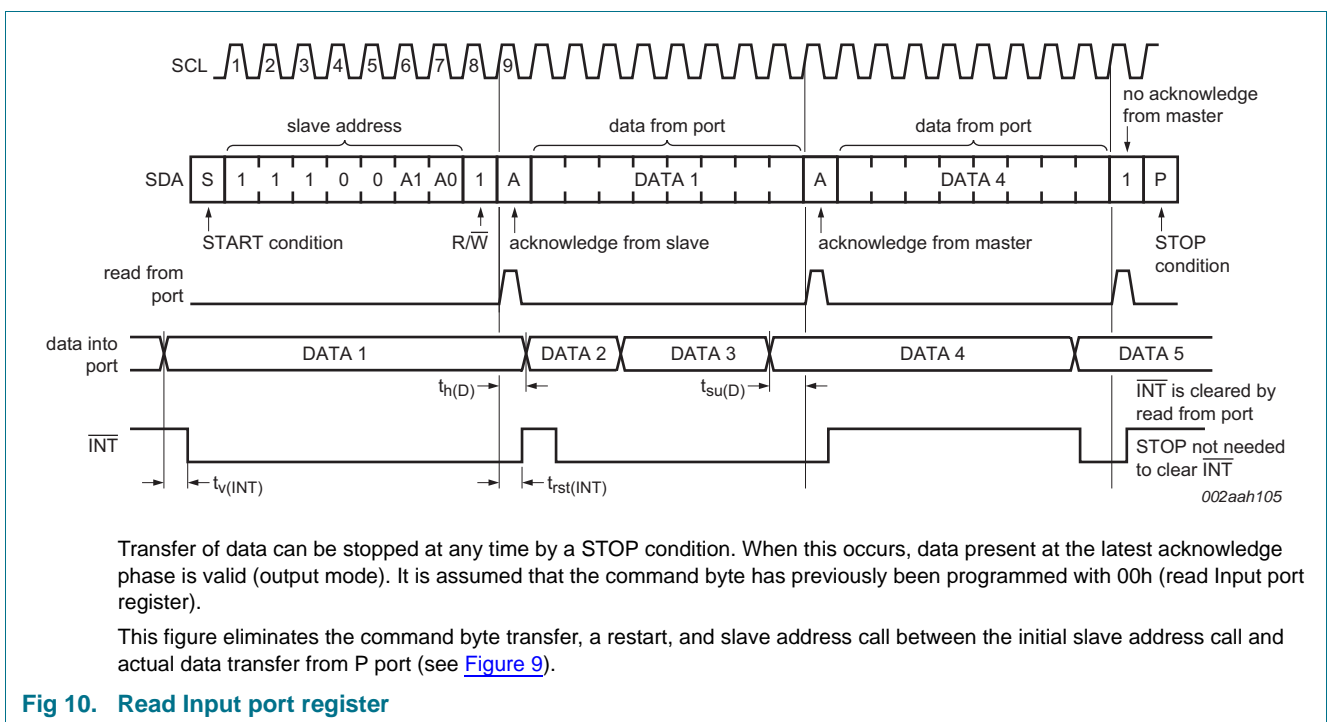

Fig 9. Read from register



Transfer of data can be stopped at any time by a STOP condition. When this occurs, data present at the latest acknowledge phase is valid (output mode). It is assumed that the command byte has previously been programmed with 00h (read Input port register).

This figure eliminates the command byte transfer, a restart, and slave address call between the initial slave address call and actual data transfer from P port (see [Figure 9](#)).

Fig 10. Read Input port register

8. Application design-in information

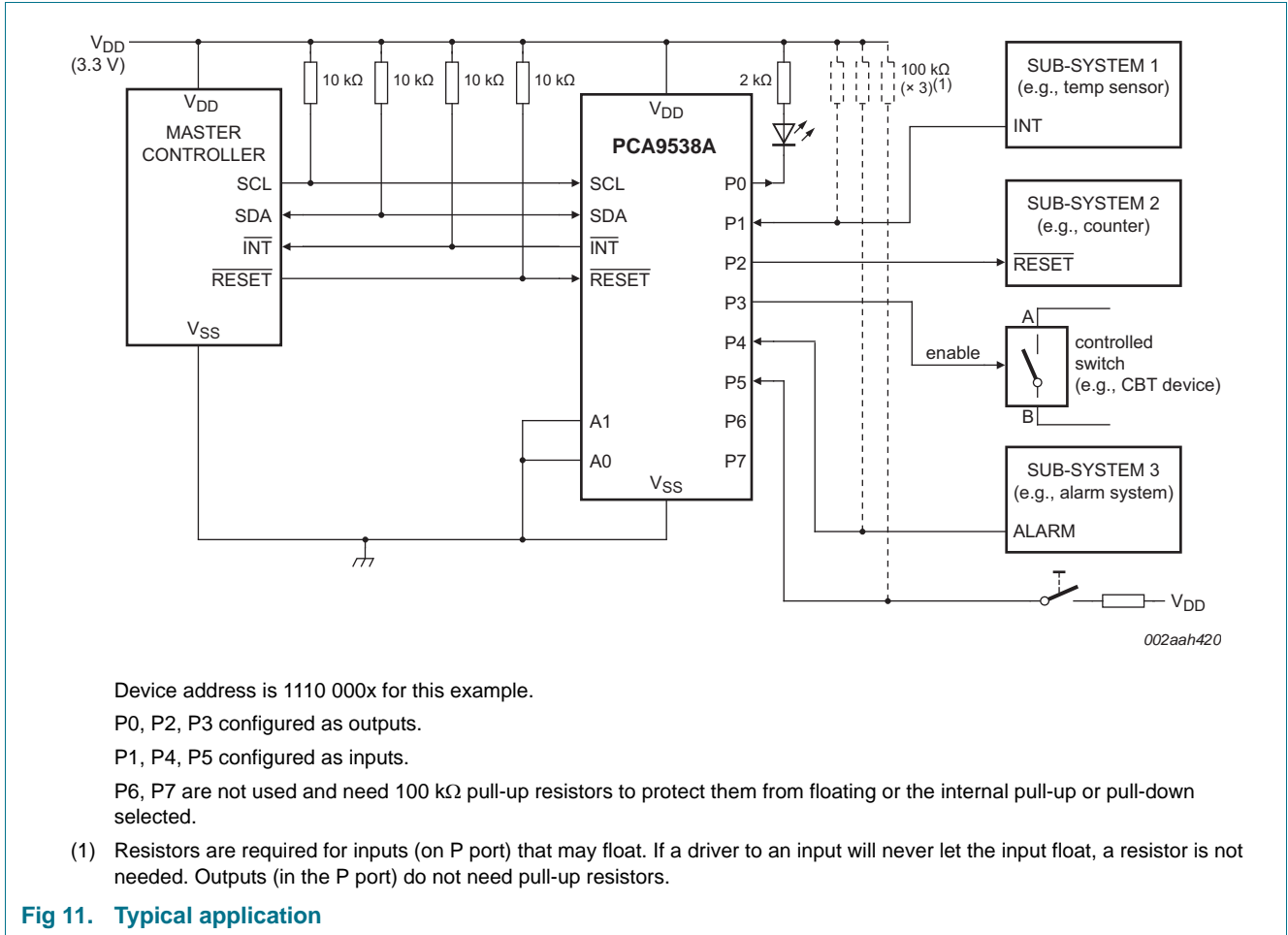

8.1 Minimizing I_{DD} when the I/Os are used to control LEDs

When the I/Os are used to control LEDs, they are normally connected to V_{DD} through a resistor as shown in [Figure 11](#). Since the LED acts as a diode, when the LED is off the I/O V_I is about 1.2 V less than V_{DD}. The supply current, I_{DD}, increases as V_I becomes lower than V_{DD}.

Designs needing to minimize current consumption, such as battery power applications, should consider maintaining the I/O pins greater than or equal to V_{DD} when the LED is off. [Figure 12](#) shows a high value resistor in parallel with the LED. [Figure 13](#) shows V_{DD} less than the LED supply voltage by at least 1.2 V. Both of these methods maintain the I/O V_I at or above V_{DD} and prevents additional supply current consumption when the LED is off.

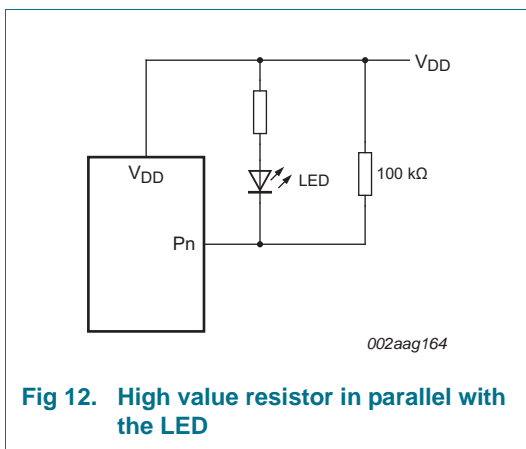

Fig 12. High value resistor in parallel with the LED

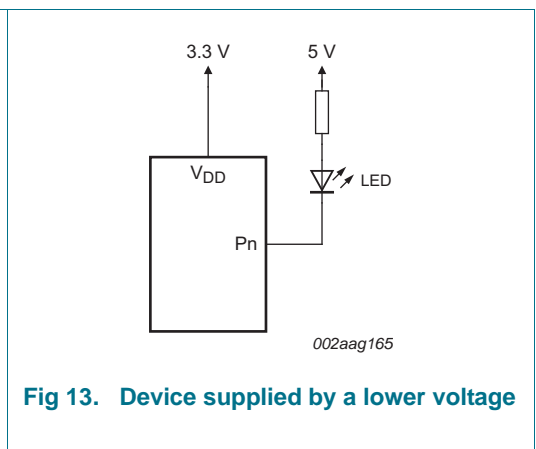

Fig 13. Device supplied by a lower voltage

8.2 12 V tolerant I/Os

The PCA9538A device SCR group reference diode can go up to 10 V before latch back to 8 V. The ESD gate oxide will protect the device, but not if used continually. Therefore, to achieve 12 V tolerant I/Os, the external protection circuitry (diode) must be used as shown in [Figure 14](#).

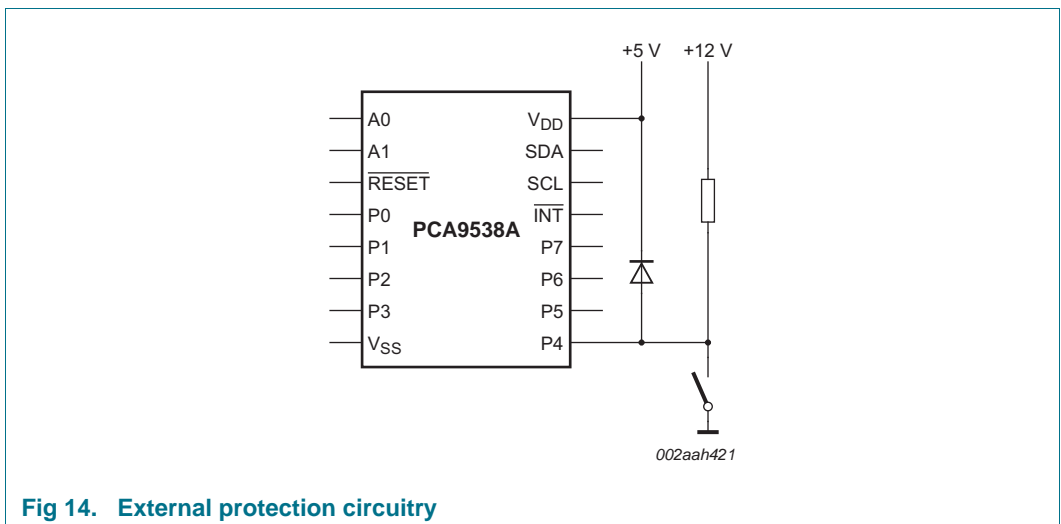

Fig 14. External protection circuitry

8.3 Power-on reset requirements

In the event of a glitch or data corruption, PCA9538A can be reset to its default conditions by using the power-on reset feature. Power-on reset requires that the device go through a power cycle to be completely reset. This reset also happens when the device is powered on for the first time in an application.

The two types of power-on reset are shown in [Figure 15](#) and [Figure 16](#).

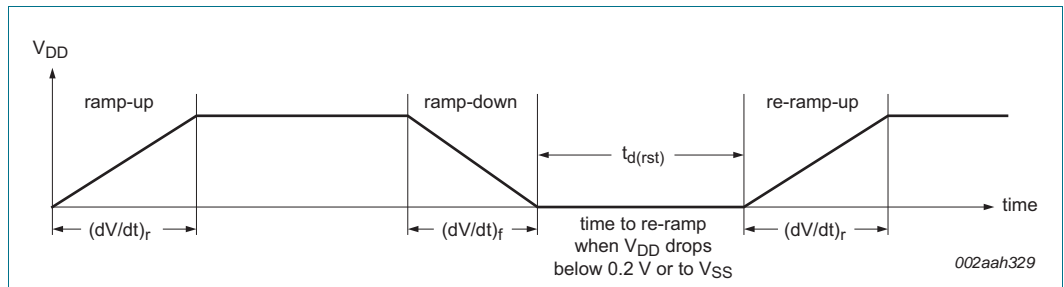

Fig 15. V_{DD} is lowered below 0.2 V or 0 V and then ramped up to V_{DD}

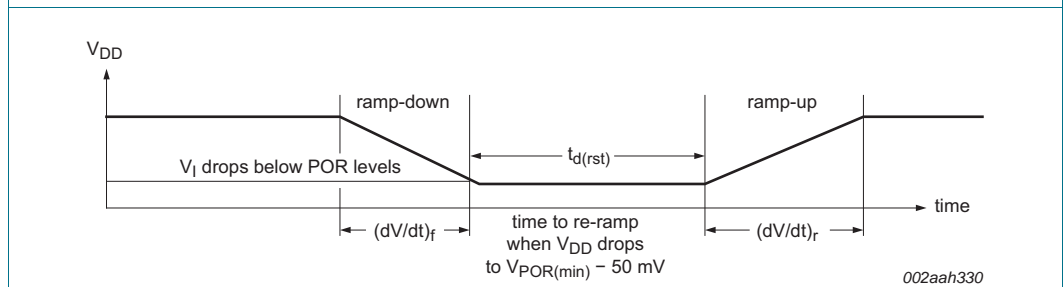

Fig 16. V_{DD} is lowered below the POR threshold, then ramped back up to V_{DD}

[Table 10](#) specifies the performance of the power-on reset feature for PCA9538A for both types of power-on reset.

Table 10. Recommended supply sequencing and ramp rates

T_{amb} = 25 °C (unless otherwise noted). Not tested; specified by design.

| Symbol | Parameter | Condition | Min | Typ | Max | Unit |
|------------------------|-----------------------------------|--|-----|-----|------|------|
| (dV/dt) _f | fall rate of change of voltage | Figure 15 | 0.1 | - | 2000 | ms |
| (dV/dt) _r | rise rate of change of voltage | Figure 15 | 0.1 | - | 2000 | ms |
| t _{d(rst)} | reset delay time | Figure 15 ; re-ramp time when V _{DD} drops to V _{SS} | 1 | - | - | μs |
| | | Figure 16 ; re-ramp time when V _{DD} drops to V _{POR(min)} - 50 mV | 1 | - | - | μs |
| ΔV _{DD(gl)} | glitch supply voltage difference | Figure 17 | [1] | - | 1.0 | V |
| t _{w(gl)VDD} | supply voltage glitch pulse width | Figure 17 | [2] | - | 10 | μs |
| V _{POR(trip)} | power-on reset trip voltage | falling V _{DD} | 0.7 | - | - | V |
| | | rising V _{DD} | - | - | 1.4 | V |

[1] Level that V_{DD} can glitch down to, but not cause a functional disruption when t_{w(gl)VDD} < 1 μs.

[2] Glitch width that will not cause a functional disruption when ΔV_{DD(gl)} = 0.5 × V_{DD}.

Glitches in the power supply can also affect the power-on reset performance of this device. The glitch width ($t_{w(g)VD D}$) and glitch height ($\Delta V_{DD(gl)}$) are dependent on each other. The bypass capacitance, source impedance, and device impedance are factors that affect power-on reset performance. [Figure 17](#) and [Table 10](#) provide more information on how to measure these specifications.

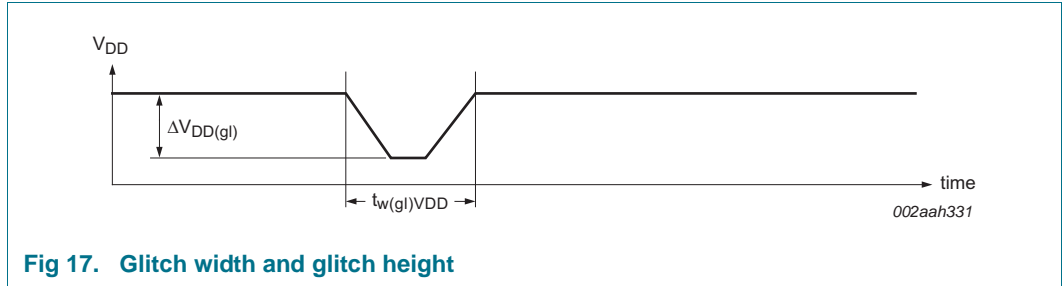

Fig 17. Glitch width and glitch height

V_{POR} is critical to the power-on reset. V_{POR} is the voltage level at which the reset condition is released and all the registers and the I²C-bus/SMBus state machine are initialized to their default states. The value of V_{POR} differs based on the V_{DD} being lowered to or from 0 V. [Figure 18](#) and [Table 10](#) provide more details on this specification.

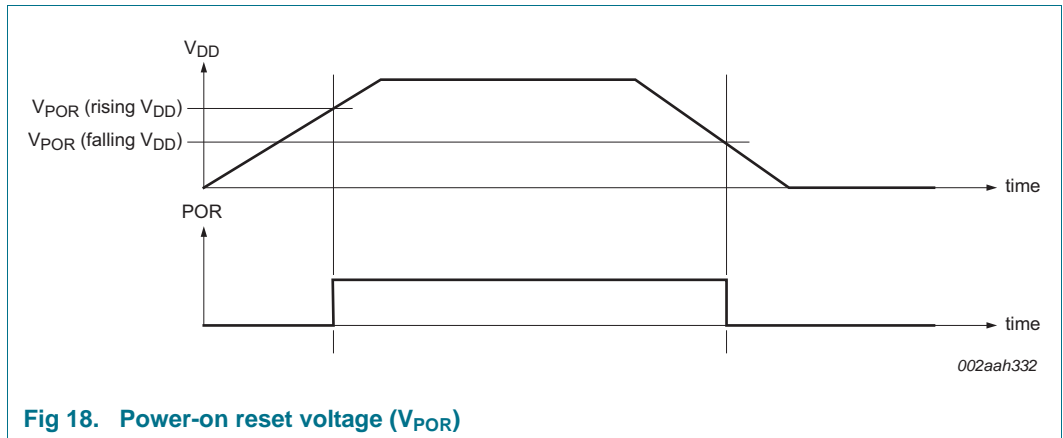

Fig 18. Power-on reset voltage (V_{POR})

9. Limiting values

Table 11. Limiting values

In accordance with the Absolute Maximum Rating System (IEC 60134).

| Symbol | Parameter | Conditions | Min | Max | Unit |
|---------------------|-------------------------------|--|----------|------|------|
| V _{DD} | supply voltage | | -0.5 | +6.5 | V |
| V _I | input voltage | | [1] -0.5 | +6.5 | V |
| V _O | output voltage | | [1] -0.5 | +6.5 | V |
| I _{IK} | input clamping current | A0, A1, $\overline{\text{RESET}}$, SCL; V _I < 0 V | - | ±20 | mA |
| I _{OK} | output clamping current | $\overline{\text{INT}}$; V _O < 0 V | - | ±20 | mA |
| I _{IOK} | input/output clamping current | P port; V _O < 0 V or V _O > V _{DD} | - | ±20 | mA |
| | | SDA; V _O < 0 V or V _O > V _{DD} | - | ±20 | mA |
| I _{OL} | LOW-level output current | continuous; I/O port | - | 50 | mA |
| | | continuous; SDA, $\overline{\text{INT}}$ | - | 25 | mA |
| I _{OH} | HIGH-level output current | continuous; P port | - | 25 | mA |
| I _{DD} | supply current | | - | 160 | mA |
| I _{SS} | ground supply current | | - | 200 | mA |
| P _{tot} | total power dissipation | | - | 200 | mW |
| T _{stg} | storage temperature | | -65 | +150 | °C |
| T _{j(max)} | maximum junction temperature | | - | 125 | °C |

[1] The input negative-voltage and output voltage ratings may be exceeded if the input and output current ratings are observed.

10. Recommended operating conditions

Table 12. Operating conditions

| Symbol | Parameter | Conditions | Min | Max | Unit |
|------------------|---------------------------|-------------------------------------|-----------------------|-----------------------|------|
| V _{DD} | supply voltage | | 1.65 | 5.5 | V |
| V _{IH} | HIGH-level input voltage | SCL, SDA, $\overline{\text{RESET}}$ | 0.7 × V _{DD} | 5.5 | V |
| | | A0, A1, P port | 0.7 × V _{DD} | 5.5 | V |
| V _{IL} | LOW-level input voltage | SCL, SDA, $\overline{\text{RESET}}$ | -0.5 | 0.3 × V _{DD} | V |
| | | A0, A1, P port | -0.5 | 0.3 × V _{DD} | V |
| I _{OH} | HIGH-level output current | P port | - | 10 | mA |
| I _{OL} | LOW-level output current | P port | - | 25 | mA |
| T _{amb} | ambient temperature | operating in free air | -40 | +85 | °C |

11. Thermal characteristics

Table 13. Thermal characteristics

| Symbol | Parameter | Conditions | Max | Unit |
|----------------------|--|-----------------|---------|------|
| Z _{th(j-a)} | transient thermal impedance from junction to ambient | HVQFN16 package | [1] 53 | K/W |
| | | TSSOP16 package | [1] 108 | K/W |

[1] The package thermal impedance is calculated in accordance with JESD 51-7.

12. Static characteristics

Table 14. Static characteristics
 $T_{amb} = -40\text{ }^{\circ}\text{C to }+85\text{ }^{\circ}\text{C}; V_{DD} = 1.65\text{ V to }5.5\text{ V};$ unless otherwise specified.

| Symbol | Parameter | Conditions | Min | Typ ^[1] | Max | Unit |
|--|---------------------------|---|--------------------|--------------------|-----|------|
| V _{IK} | input clamping voltage | I _I = -18 mA | -1.2 | - | - | V |
| V _{POR} | power-on reset voltage | V _I = V _{DD} or V _{SS} ; I _O = 0 mA | - | 1.1 | 1.4 | V |
| I _{OL} | LOW-level output current | V _{OL} = 0.4 V; V _{DD} = 1.65 V to 5.5 V | | | | |
| | | SDA | 3 | - | - | mA |
| | | $\overline{\text{INT}}$ | 3 | 15 ^[2] | - | mA |
| | | P port | | | | |
| | | V _{OL} = 0.5 V; V _{DD} = 1.65 V | ^[3] 8 | 10 | - | mA |
| | | V _{OL} = 0.7 V; V _{DD} = 1.65 V | ^[3] 10 | 13 | - | mA |
| | | V _{OL} = 0.5 V; V _{DD} = 2.3 V | ^[3] 8 | 10 | - | mA |
| | | V _{OL} = 0.7 V; V _{DD} = 2.3 V | ^[3] 10 | 13 | - | mA |
| | | V _{OL} = 0.5 V; V _{DD} = 3.0 V | ^[3] 8 | 14 | - | mA |
| | | V _{OL} = 0.7 V; V _{DD} = 3.0 V | ^[3] 10 | 19 | - | mA |
| V _{OH} | HIGH-level output voltage | P port | | | | |
| | | I _{OH} = -8 mA; V _{DD} = 1.65 V | ^[4] 1.2 | - | - | V |
| | | I _{OH} = -10 mA; V _{DD} = 1.65 V | ^[4] 1.1 | - | - | V |
| | | I _{OH} = -8 mA; V _{DD} = 2.3 V | ^[4] 1.8 | - | - | V |
| | | I _{OH} = -10 mA; V _{DD} = 2.3 V | ^[4] 1.7 | - | - | V |
| | | I _{OH} = -8 mA; V _{DD} = 3.0 V | ^[4] 2.6 | - | - | V |
| | | I _{OH} = -10 mA; V _{DD} = 3.0 V | ^[4] 2.5 | - | - | V |
| | | I _{OH} = -8 mA; V _{DD} = 4.75 V | ^[4] 4.1 | - | - | V |
| I _{OH} = -10 mA; V _{DD} = 4.75 V | ^[4] 4.0 | - | - | V | | |
| I _I | input current | V _{DD} = 1.65 V to 5.5 V | | | | |
| | | SCL, SDA, $\overline{\text{RESET}}$; V _I = V _{DD} or V _{SS} | - | - | 0.1 | μA |
| | | A0, A1; V _I = V _{DD} or V _{SS} | - | - | ±1 | μA |
| I _{IH} | HIGH-level input current | P port; V _I = V _{DD} ; V _{DD} = 1.65 V to 5.5 V | - | - | 1 | μA |
| I _{IL} | LOW-level input current | P port; V _I = V _{SS} ; V _{DD} = 1.65 V to 5.5 V | - | - | 1 | μA |

Table 14. Static characteristics ...continued

$T_{amb} = -40\text{ }^{\circ}\text{C}$ to $+85\text{ }^{\circ}\text{C}$; $V_{DD} = 1.65\text{ V}$ to 5.5 V ; unless otherwise specified.

| Symbol | Parameter | Conditions | Min | Typ ^[1] | Max | Unit | |
|---|--------------------------|---|-------------------------------------|---|-----|---------------|----|
| I_{DD} | supply current | SDA, P port, A0, A1, $\overline{\text{RESET}}$; V_I on SDA, $\overline{\text{RESET}} = V_{DD}$ or V_{SS} ; V_I on P port and A0, A1, A2 = V_{DD} ; $I_O = 0\text{ mA}$; I/O = inputs; $f_{SCL} = 400\text{ kHz}$ | | | | | |
| | | $V_{DD} = 3.6\text{ V}$ to 5.5 V | - | 10 | 25 | μA | |
| | | $V_{DD} = 2.3\text{ V}$ to 3.6 V | - | 6.5 | 15 | μA | |
| | | $V_{DD} = 1.65\text{ V}$ to 2.3 V | - | 4 | 9 | μA | |
| | | SCL, SDA, P port, A0, A1, $\overline{\text{RESET}}$; V_I on SCL, SDA, $\overline{\text{RESET}} = V_{DD}$ or V_{SS} ; V_I on P port and A0, A1, A2 = V_{DD} ; $I_O = 0\text{ mA}$; I/O = inputs; $f_{SCL} = 0\text{ kHz}$ | | | | | |
| | | $V_{DD} = 3.6\text{ V}$ to 5.5 V | - | 1.5 | 7 | μA | |
| | | $V_{DD} = 2.3\text{ V}$ to 3.6 V | - | 1 | 3.2 | μA | |
| | | $V_{DD} = 1.65\text{ V}$ to 2.3 V | - | 0.5 | 1.7 | μA | |
| | | ΔI_{DD} | additional quiescent supply current | SCL, SDA, $\overline{\text{RESET}}$; one input at $V_{DD} - 0.6\text{ V}$, other inputs at V_{DD} or V_{SS} ; $V_{DD} = 1.65\text{ V}$ to 5.5 V | - | - | 25 |
| P port, A0, A1, $\overline{\text{RESET}}$; one input at $V_{DD} - 0.6\text{ V}$, other inputs at V_{DD} or V_{SS} ; $V_{DD} = 1.65\text{ V}$ to 5.5 V | - | | | - | 80 | μA | |
| C_i | input capacitance | $V_I = V_{DD}$ or V_{SS} ; $V_{DD} = 1.65\text{ V}$ to 5.5 V | - | 6 | 7 | pF | |
| C_{iO} | input/output capacitance | $V_{I/O} = V_{DD}$ or V_{SS} ; $V_{DD} = 1.65\text{ V}$ to 5.5 V | - | 7 | 8 | pF | |
| | | $V_{I/O} = V_{DD}$ or V_{SS} ; $V_{DD} = 1.65\text{ V}$ to 5.5 V | - | 7.5 | 8.5 | pF | |

- [1] For I_{DD} , all typical values are at nominal supply voltage (1.8 V, 2.5 V, 3.3 V, 3.6 V or 5 V V_{DD}) and $T_{amb} = 25\text{ }^{\circ}\text{C}$. Except for I_{DD} , the typical values are at $V_{DD} = 3.3\text{ V}$ and $T_{amb} = 25\text{ }^{\circ}\text{C}$.
- [2] Typical value for $T_{amb} = 25\text{ }^{\circ}\text{C}$. $V_{OL} = 0.4\text{ V}$ and $V_{DD} = 3.3\text{ V}$. Typical value for $V_{DD} < 2.5\text{ V}$, $V_{OL} = 0.6\text{ V}$.
- [3] Each I/O must be externally limited to a maximum of 25 mA and the device must be limited to a maximum current of 100 mA.
- [4] The total current sourced by all I/Os must be limited to 85 mA.

12.1 Typical characteristics

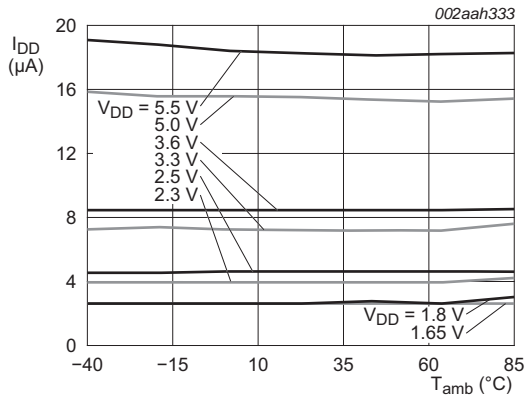

Fig 19. Supply current versus ambient temperature

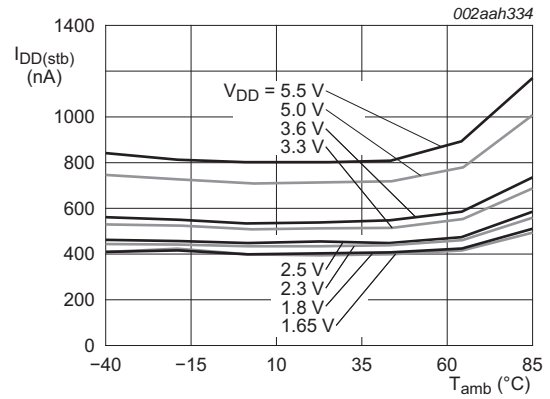
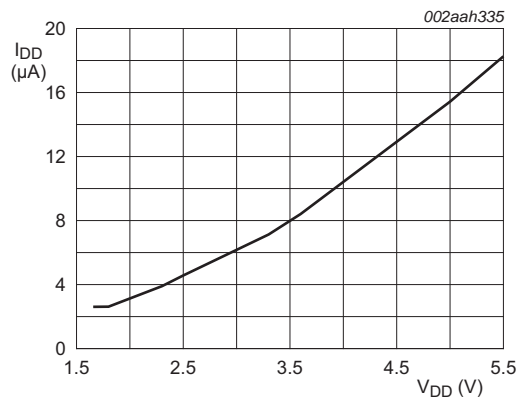
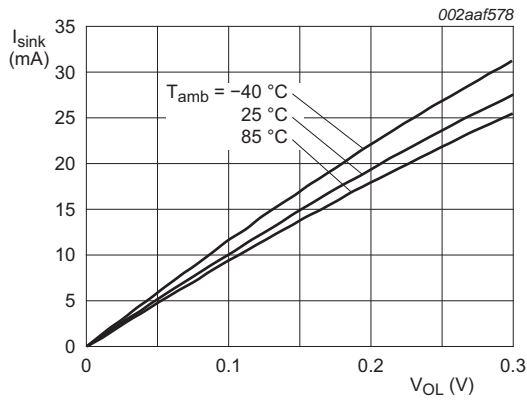

Fig 20. Standby supply current versus ambient temperature



T_{amb} = 25 °C

Fig 21. Supply current versus supply voltage



a. $V_{DD} = 1.65 \text{ V}$

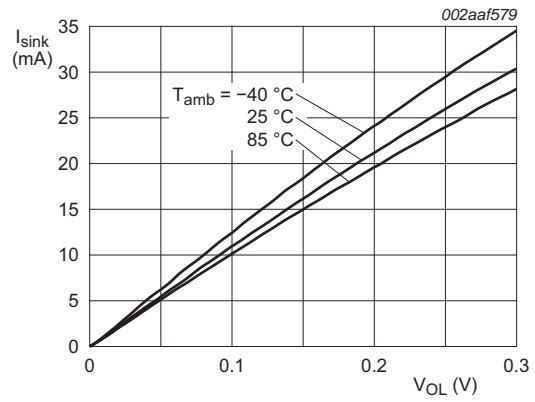

b. $V_{DD} = 1.8 \text{ V}$

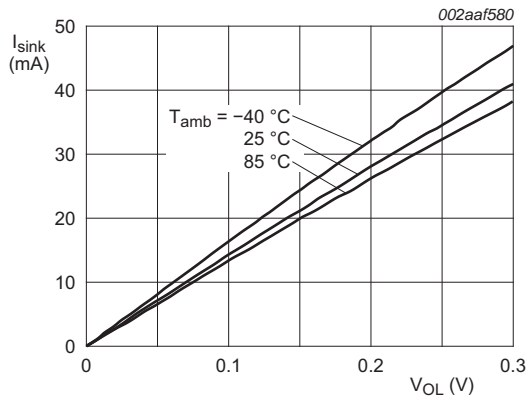

c. $V_{DD} = 2.5 \text{ V}$

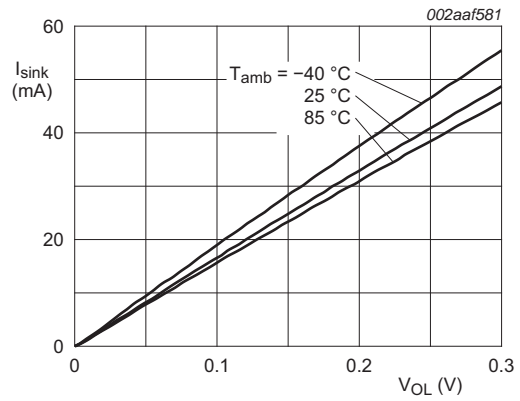

d. $V_{DD} = 3.3 \text{ V}$

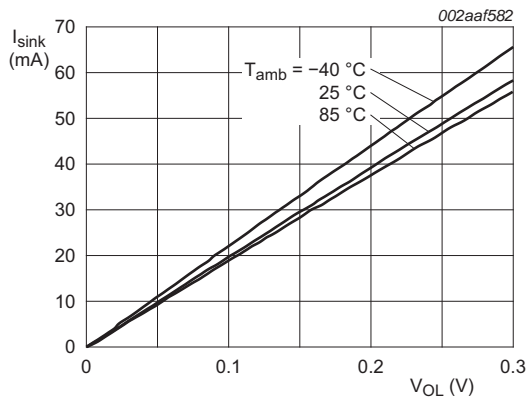

e. $V_{DD} = 5.0 \text{ V}$

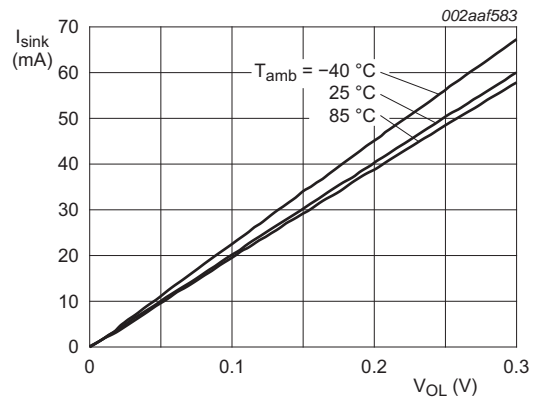

f. $V_{DD} = 5.5 \text{ V}$

Fig 22. I/O sink current versus LOW-level output voltage

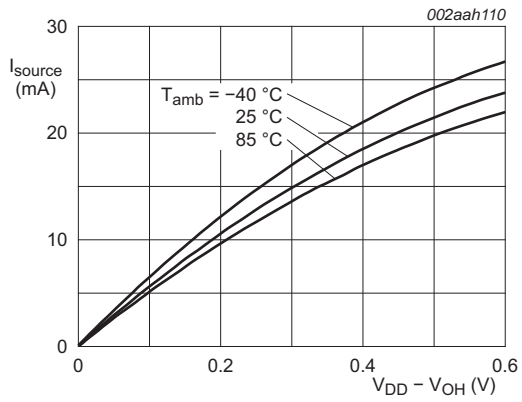

a. $V_{DD} = 1.65\text{ V}$

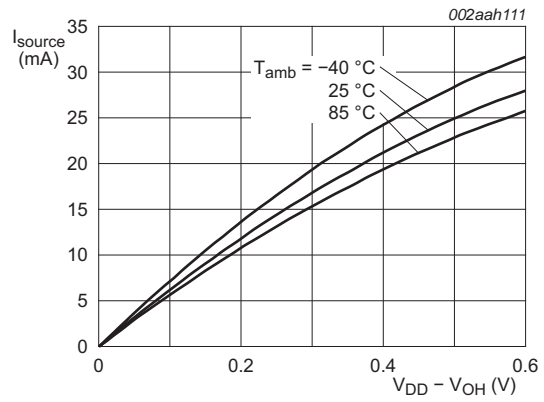

b. $V_{DD} = 1.8\text{ V}$

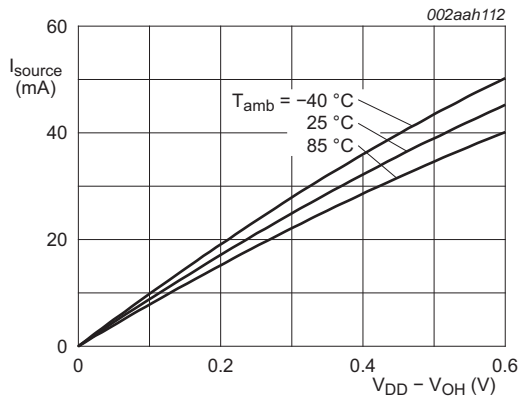

c. $V_{DD} = 2.5\text{ V}$

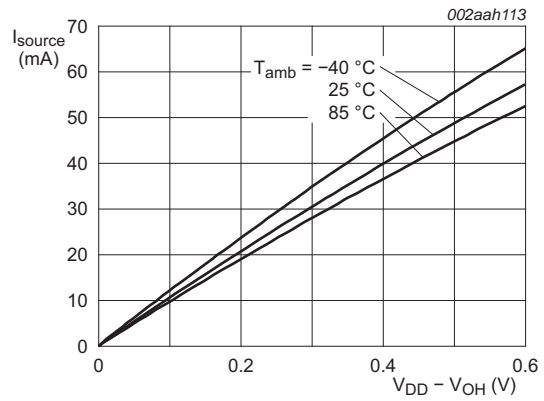

d. $V_{DD} = 3.3\text{ V}$

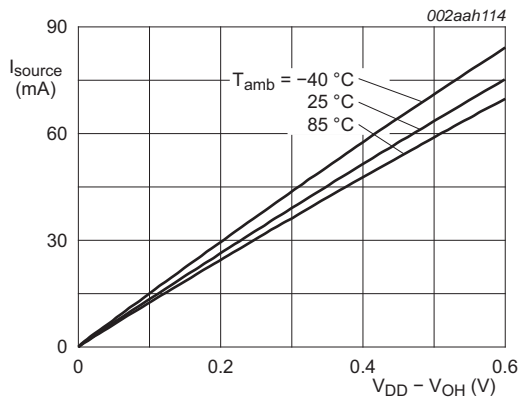

e. $V_{DD} = 5.0\text{ V}$

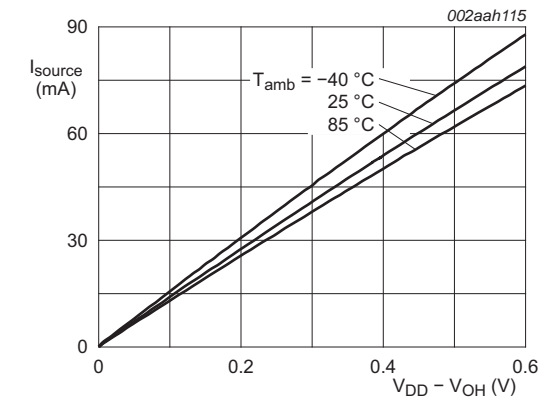

f. $V_{DD} = 5.5\text{ V}$

Fig 23. I/O source current versus HIGH-level output voltage

Low-voltage 8-bit I²C-bus I/O port with interrupt and reset

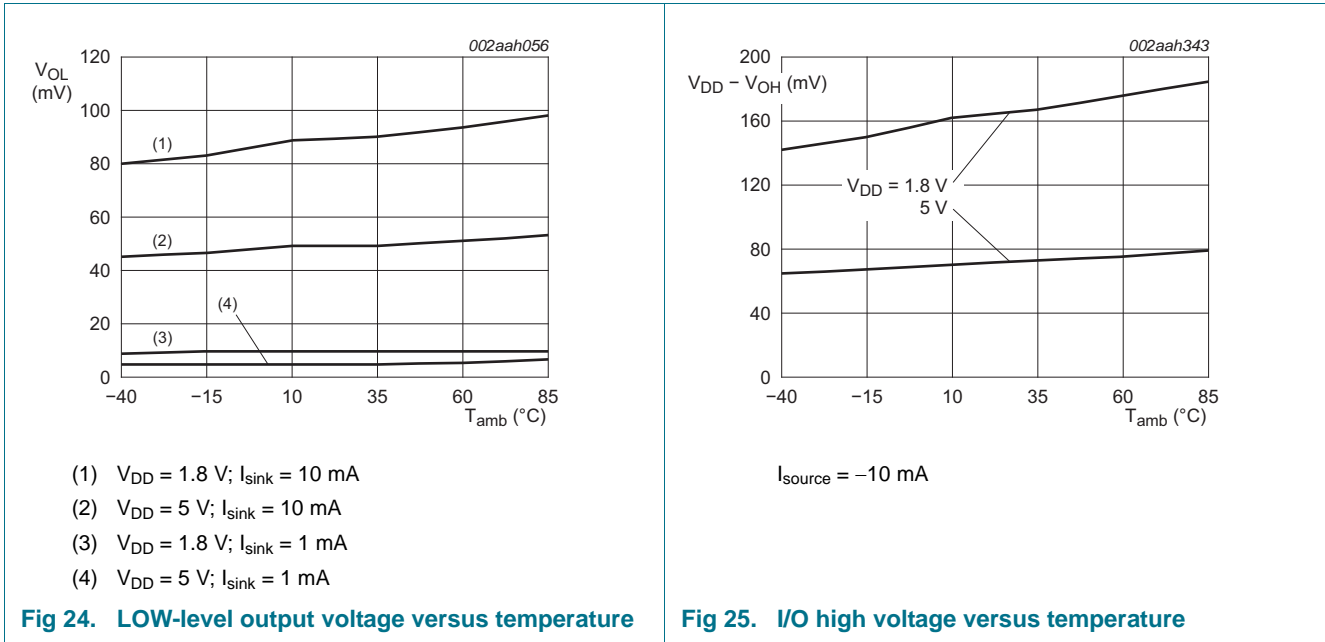

13. Dynamic characteristics

Table 15. I²C-bus interface timing requirements

Over recommended operating free air temperature range, unless otherwise specified. See [Figure 26](#).

| Symbol | Parameter | Conditions | Standard-mode I ² C-bus | | Fast-mode I ² C-bus | | Unit |
|---------------------|---|--|------------------------------------|------|-----------------------------------|-----|------|
| | | | Min | Max | Min | Max | |
| f _{SCL} | SCL clock frequency | | 0 | 100 | 0 | 400 | kHz |
| t _{HIGH} | HIGH period of the SCL clock | | 4 | - | 0.6 | - | μs |
| t _{LOW} | LOW period of the SCL clock | | 4.7 | - | 1.3 | - | μs |
| t _{SP} | pulse width of spikes that must be suppressed by the input filter | | 0 | 50 | 0 | 50 | ns |
| t _{SU;DAT} | data set-up time | | 250 | - | 100 | - | ns |
| t _{HD;DAT} | data hold time | | 0 | - | 0 | - | ns |
| t _r | rise time of both SDA and SCL signals | | - | 1000 | 20 | 300 | ns |
| t _f | fall time of both SDA and SCL signals | | - | 300 | 20 × (V _{DD} / 5.5 V) | 300 | ns |
| t _{BUF} | bus free time between a STOP and START condition | | 4.7 | - | 1.3 | - | μs |
| t _{SU;STA} | set-up time for a repeated START condition | | 4.7 | - | 0.6 | - | μs |
| t _{HD;STA} | hold time (repeated) START condition | | 4 | - | 0.6 | - | μs |
| t _{SU;STO} | set-up time for STOP condition | | 4 | - | 0.6 | - | μs |
| t _{VD;DAT} | data valid time | SCL LOW to SDA output valid | - | 3.45 | - | 0.9 | μs |
| t _{VD;ACK} | data valid acknowledge time | ACK signal from SCL LOW to SDA (out) LOW | - | 3.45 | - | 0.9 | μs |

Table 16. Reset timing requirements

Over recommended operating free air temperature range, unless otherwise specified. See [Figure 29](#).

| Symbol | Parameter | Conditions | Standard-mode I ² C-bus | | Fast-mode I ² C-bus | | Unit |
|-----------------------|---------------------|------------|------------------------------------|-----|--------------------------------|-----|------|
| | | | Min | Max | Min | Max | |
| t _{w(rst)} | reset pulse width | | 30 | - | 30 | - | ns |
| t _{rec(rst)} | reset recovery time | | 200 | - | 200 | - | ns |
| t _{rst} | reset time | [1] | 600 | - | 600 | - | ns |

[1] Minimum time for SDA to become HIGH or minimum time to wait before doing a START.

Table 17. Switching characteristics

Over recommended operating free air temperature range; $C_L \leq 100$ pF; unless otherwise specified. See [Figure 26](#).

| Symbol | Parameter | Conditions | Standard-mode I ² C-bus | | Fast-mode I ² C-bus | | Unit |
|----------------|------------------------------------|---------------------------------|------------------------------------|-----|--------------------------------|-----|---------|
| | | | Min | Max | Min | Max | |
| $t_{v(INT)}$ | valid time on pin \overline{INT} | from P port to \overline{INT} | - | 1 | - | 1 | μ s |
| $t_{rst(INT)}$ | reset time on pin \overline{INT} | from SCL to \overline{INT} | - | 1 | - | 1 | μ s |
| $t_{v(Q)}$ | data output valid time | from SCL to P port | - | 400 | - | 400 | ns |
| $t_{su(D)}$ | data input set-up time | from P port to SCL | 0 | - | 0 | - | ns |
| $t_{h(D)}$ | data input hold time | from P port to SCL | 300 | - | 300 | - | ns |

14. Parameter measurement information

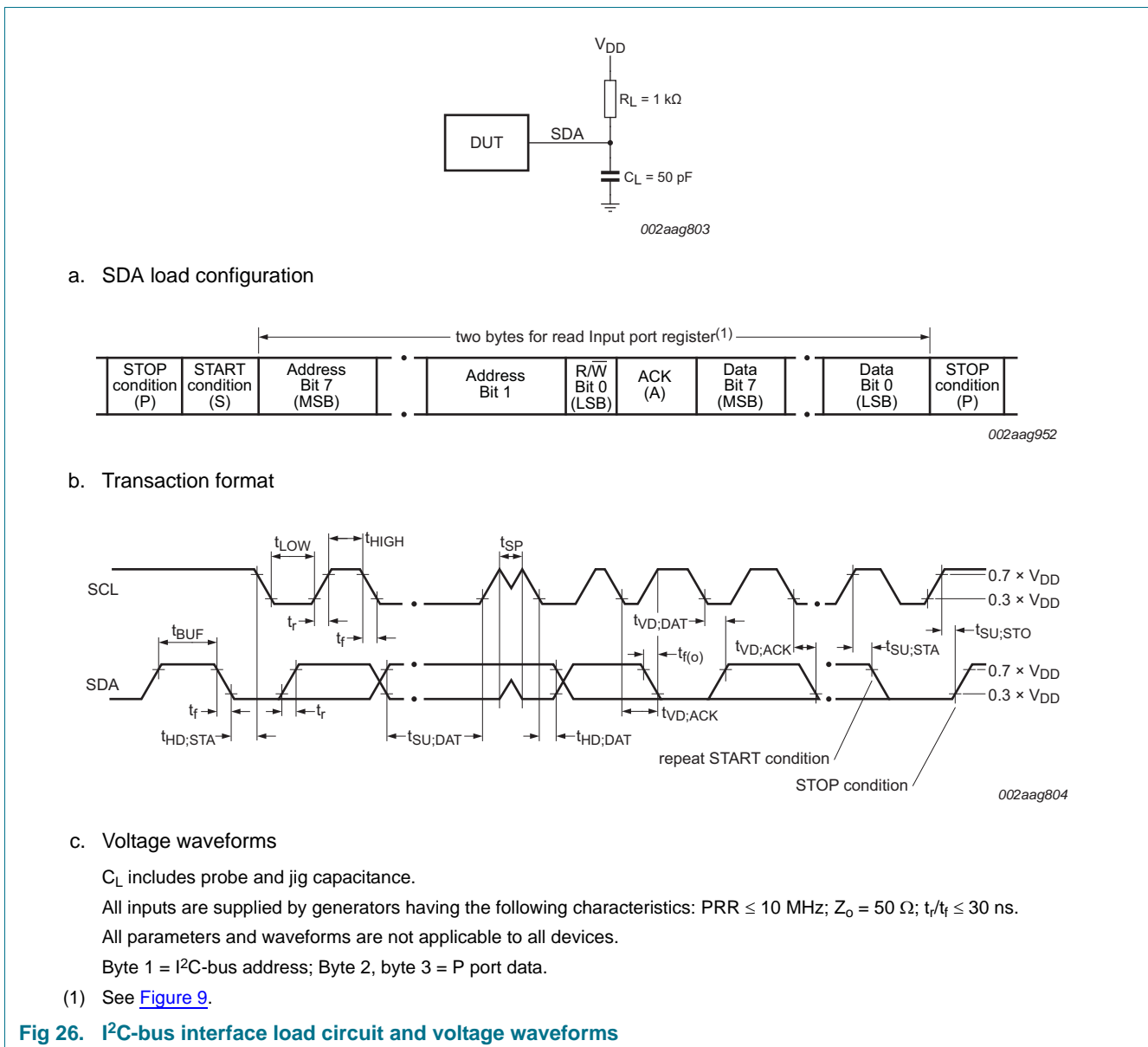

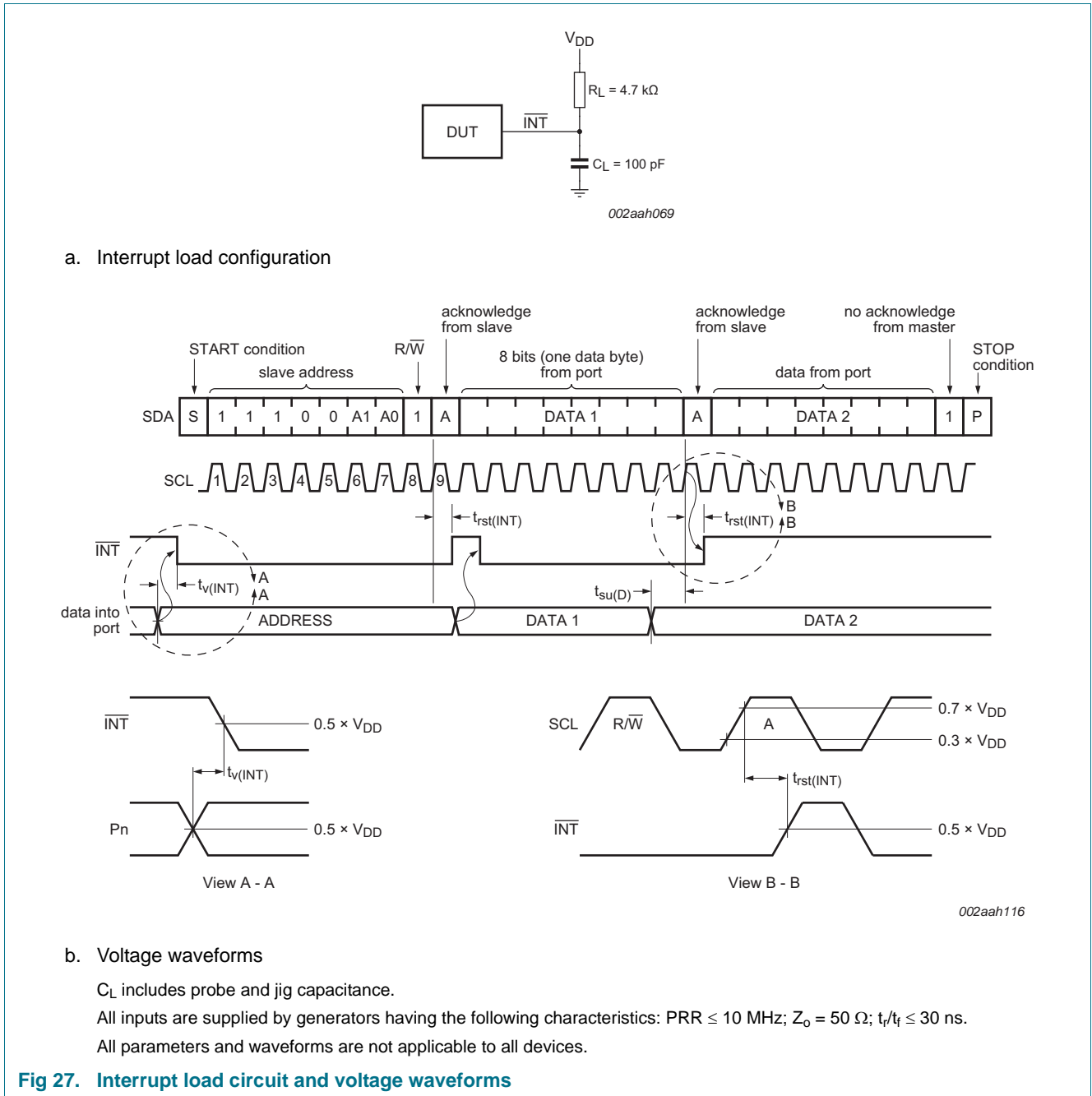
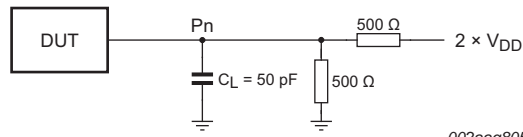
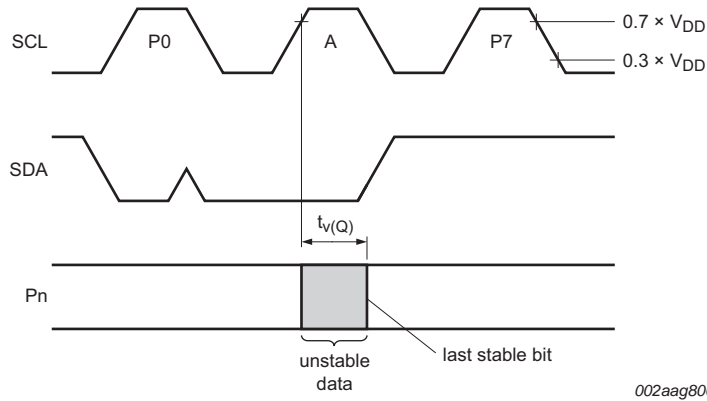

Fig 27. Interrupt load circuit and voltage waveforms



a. P port load configuration



b. Write mode ($\overline{R/\overline{W}} = 0$)

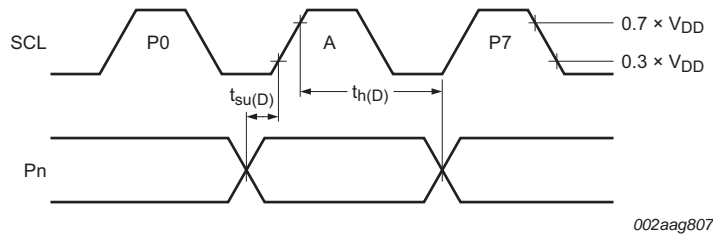

c. Read mode ($\overline{R/\overline{W}} = 1$)

C_L includes probe and jig capacitance.

$t_{V(Q)}$ is measured from $0.7 \times V_{DD}$ on SCL to 50 % I/O (P_n) output.

All inputs are supplied by generators having the following characteristics: PRR \leq 10 MHz; $Z_o = 50 \Omega$; $t_r/t_f \leq 30$ ns.

The outputs are measured one at a time, with one transition per measurement.

All parameters and waveforms are not applicable to all devices.

Fig 28. P port load circuit and voltage waveforms

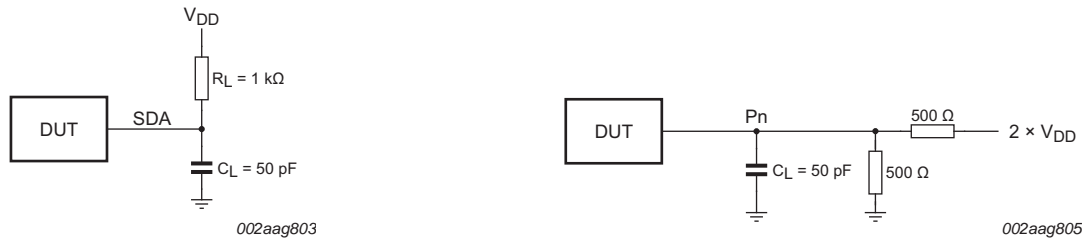

a. SDA load configuration

b. P port load configuration

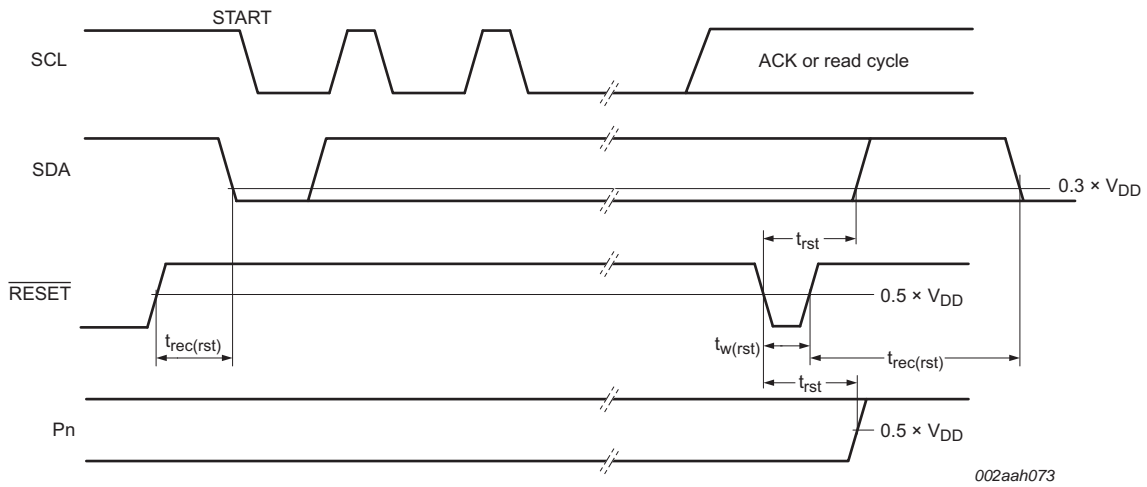

c. RESET timing

C_L includes probe and jig capacitance.

All inputs are supplied by generators having the following characteristics: $PRR \leq 10\text{ MHz}$; $Z_o = 50\ \Omega$; $t_r/t_f \leq 30\text{ ns}$.

The outputs are measured one at a time, with one transition per measurement.

I/Os are configured as inputs.

All parameters and waveforms are not applicable to all devices.

Fig 29. Reset load circuits and voltage waveforms

15. Package outline

TSSOP16: plastic thin shrink small outline package; 16 leads; body width 4.4 mm

SOT403-1

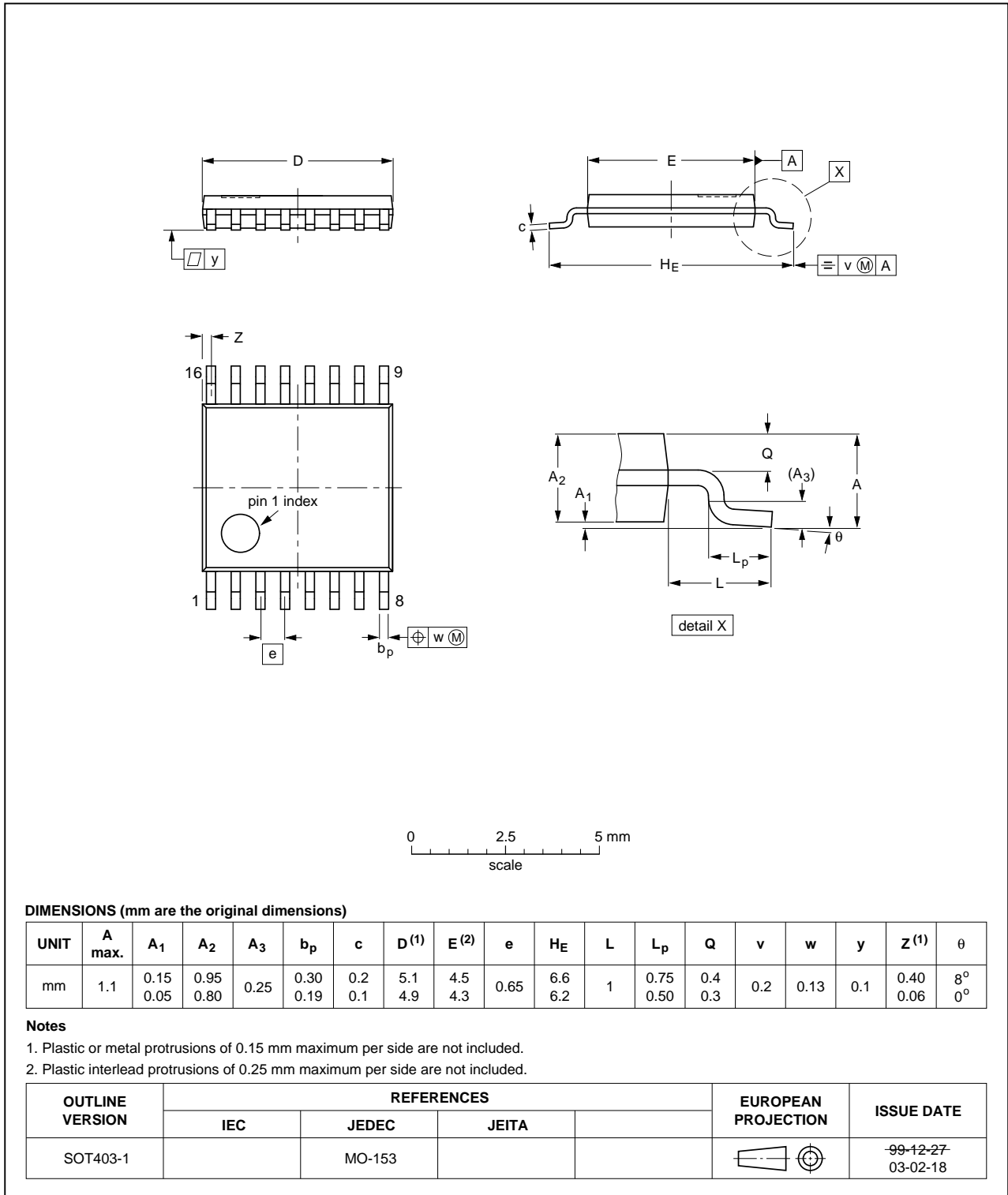

Fig 30. Package outline SOT403-1 (TSSOP16)

HVQFN16: plastic thermal enhanced very thin quad flat package; no leads; 16 terminals; body 3 x 3 x 0.85 mm

SOT758-1

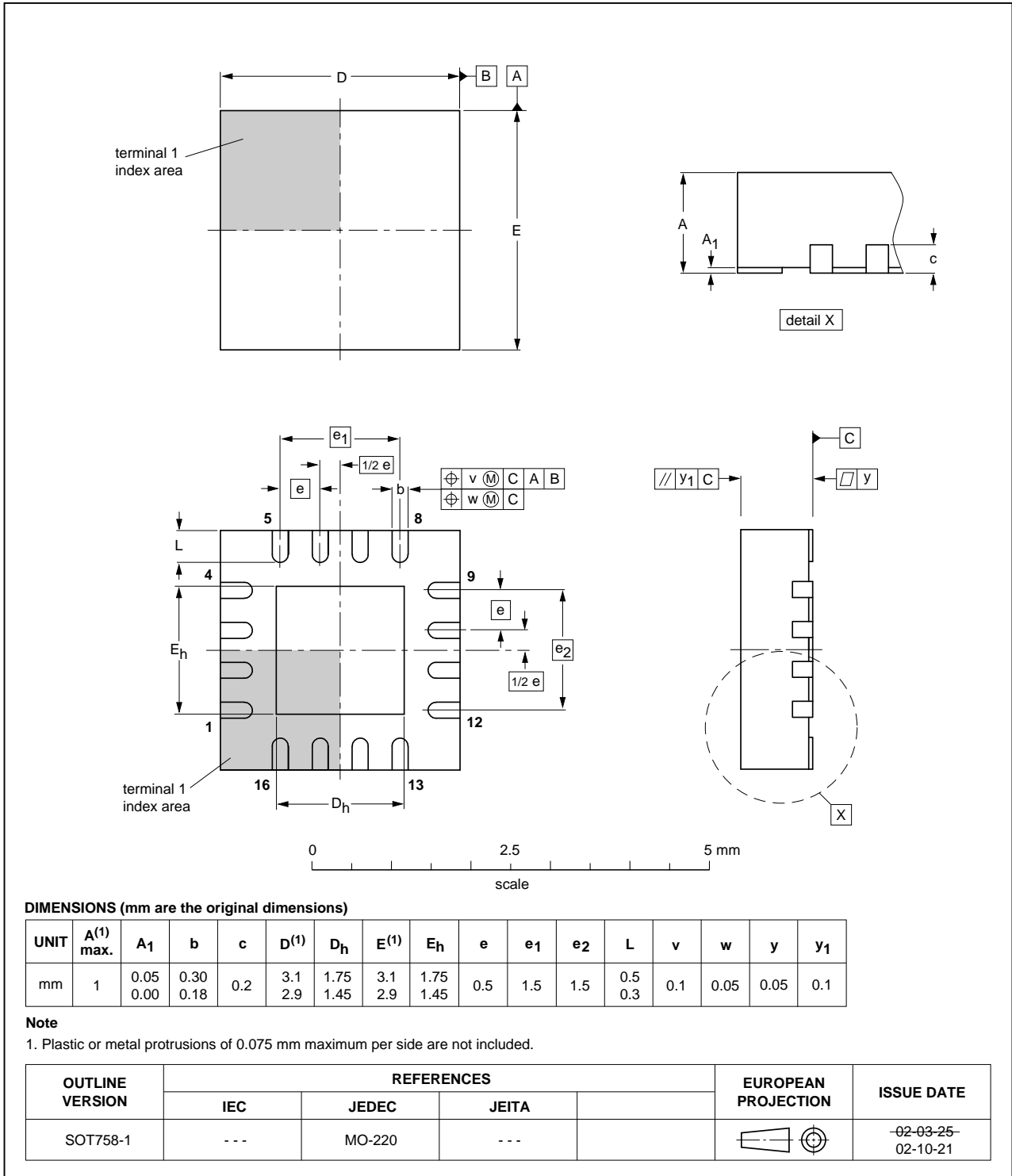

Fig 31. Package outline SOT758-1 (HVQFN16)

16. Handling information

All input and output pins are protected against ElectroStatic Discharge (ESD) under normal handling. When handling ensure that the appropriate precautions are taken as described in *JESD625-A* or equivalent standards.

17. Soldering of SMD packages

This text provides a very brief insight into a complex technology. A more in-depth account of soldering ICs can be found in Application Note *AN10365 "Surface mount reflow soldering description"*.

17.1 Introduction to soldering

Soldering is one of the most common methods through which packages are attached to Printed Circuit Boards (PCBs), to form electrical circuits. The soldered joint provides both the mechanical and the electrical connection. There is no single soldering method that is ideal for all IC packages. Wave soldering is often preferred when through-hole and Surface Mount Devices (SMDs) are mixed on one printed wiring board; however, it is not suitable for fine pitch SMDs. Reflow soldering is ideal for the small pitches and high densities that come with increased miniaturization.

17.2 Wave and reflow soldering

Wave soldering is a joining technology in which the joints are made by solder coming from a standing wave of liquid solder. The wave soldering process is suitable for the following:

- Through-hole components
- Leaded or leadless SMDs, which are glued to the surface of the printed circuit board

Not all SMDs can be wave soldered. Packages with solder balls, and some leadless packages which have solder lands underneath the body, cannot be wave soldered. Also, leaded SMDs with leads having a pitch smaller than ~0.6 mm cannot be wave soldered, due to an increased probability of bridging.

The reflow soldering process involves applying solder paste to a board, followed by component placement and exposure to a temperature profile. Leaded packages, packages with solder balls, and leadless packages are all reflow solderable.

Key characteristics in both wave and reflow soldering are:

- Board specifications, including the board finish, solder masks and vias
- Package footprints, including solder thieves and orientation
- The moisture sensitivity level of the packages
- Package placement
- Inspection and repair
- Lead-free soldering versus SnPb soldering

17.3 Wave soldering

Key characteristics in wave soldering are:

- Process issues, such as application of adhesive and flux, clinching of leads, board transport, the solder wave parameters, and the time during which components are exposed to the wave
- Solder bath specifications, including temperature and impurities

17.4 Reflow soldering

Key characteristics in reflow soldering are:

- Lead-free versus SnPb soldering; note that a lead-free reflow process usually leads to higher minimum peak temperatures (see [Figure 32](#)) than a SnPb process, thus reducing the process window
- Solder paste printing issues including smearing, release, and adjusting the process window for a mix of large and small components on one board
- Reflow temperature profile; this profile includes preheat, reflow (in which the board is heated to the peak temperature) and cooling down. It is imperative that the peak temperature is high enough for the solder to make reliable solder joints (a solder paste characteristic). In addition, the peak temperature must be low enough that the packages and/or boards are not damaged. The peak temperature of the package depends on package thickness and volume and is classified in accordance with [Table 18](#) and [19](#)

Table 18. SnPb eutectic process (from J-STD-020C)

| Package thickness (mm) | Package reflow temperature (°C) | |
|------------------------|---------------------------------|-------|
| | Volume (mm ³) | |
| | < 350 | ≥ 350 |
| < 2.5 | 235 | 220 |
| ≥ 2.5 | 220 | 220 |

Table 19. Lead-free process (from J-STD-020C)

| Package thickness (mm) | Package reflow temperature (°C) | | |
|------------------------|---------------------------------|-------------|--------|
| | Volume (mm ³) | | |
| | < 350 | 350 to 2000 | > 2000 |
| < 1.6 | 260 | 260 | 260 |
| 1.6 to 2.5 | 260 | 250 | 245 |
| > 2.5 | 250 | 245 | 245 |

Moisture sensitivity precautions, as indicated on the packing, must be respected at all times.

Studies have shown that small packages reach higher temperatures during reflow soldering, see [Figure 32](#).

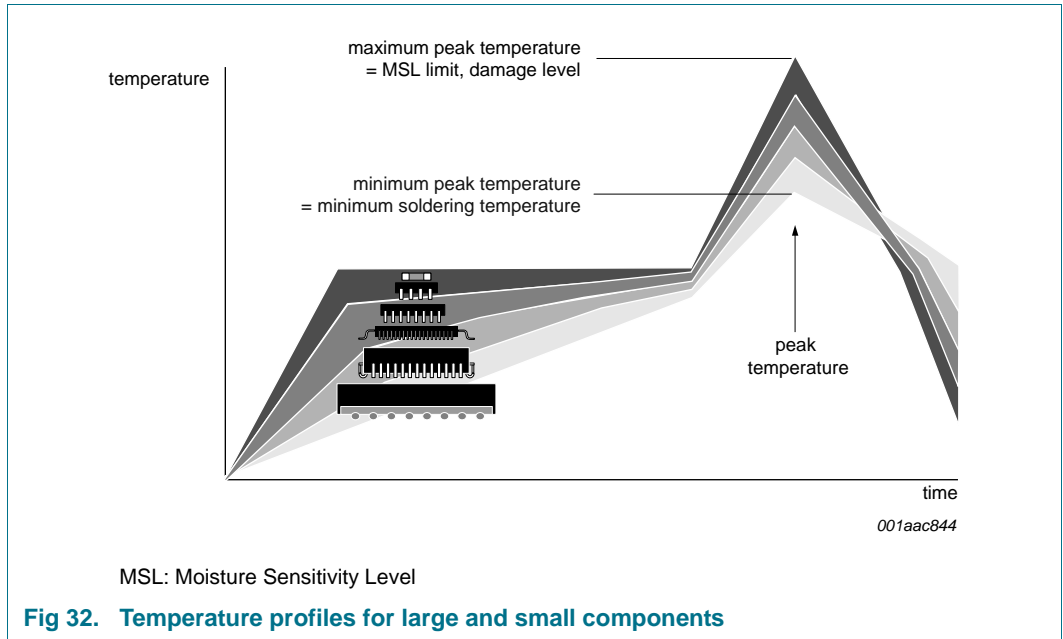

For further information on temperature profiles, refer to Application Note AN10365 “Surface mount reflow soldering description”.

18. Soldering: PCB footprints

Footprint information for reflow soldering of HVQFN16 package

SOT758-1

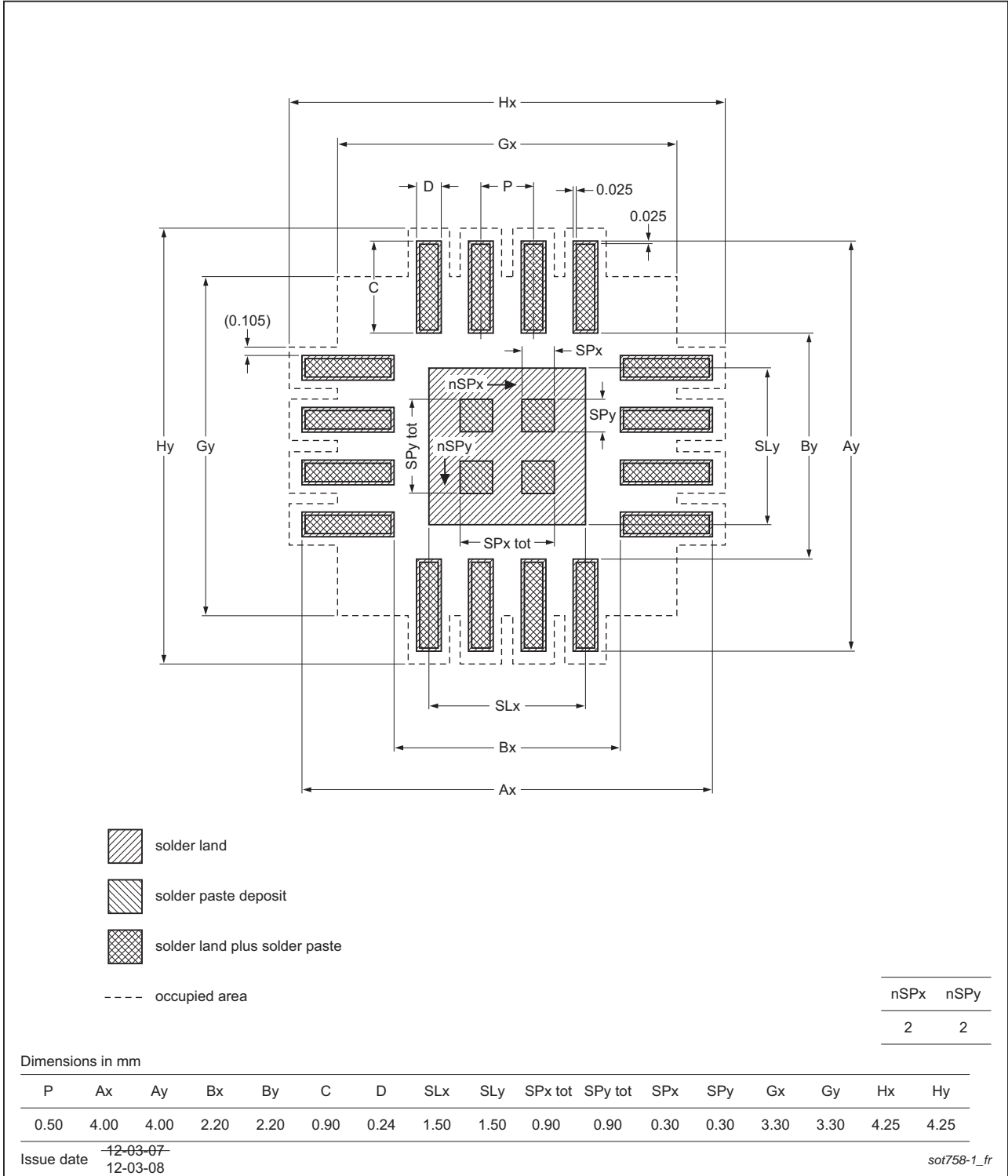

Fig 33. PCB footprint for SOT758-1 (HVQFN16); reflow soldering

Footprint information for reflow soldering of TSSOP16 package

SOT403-1

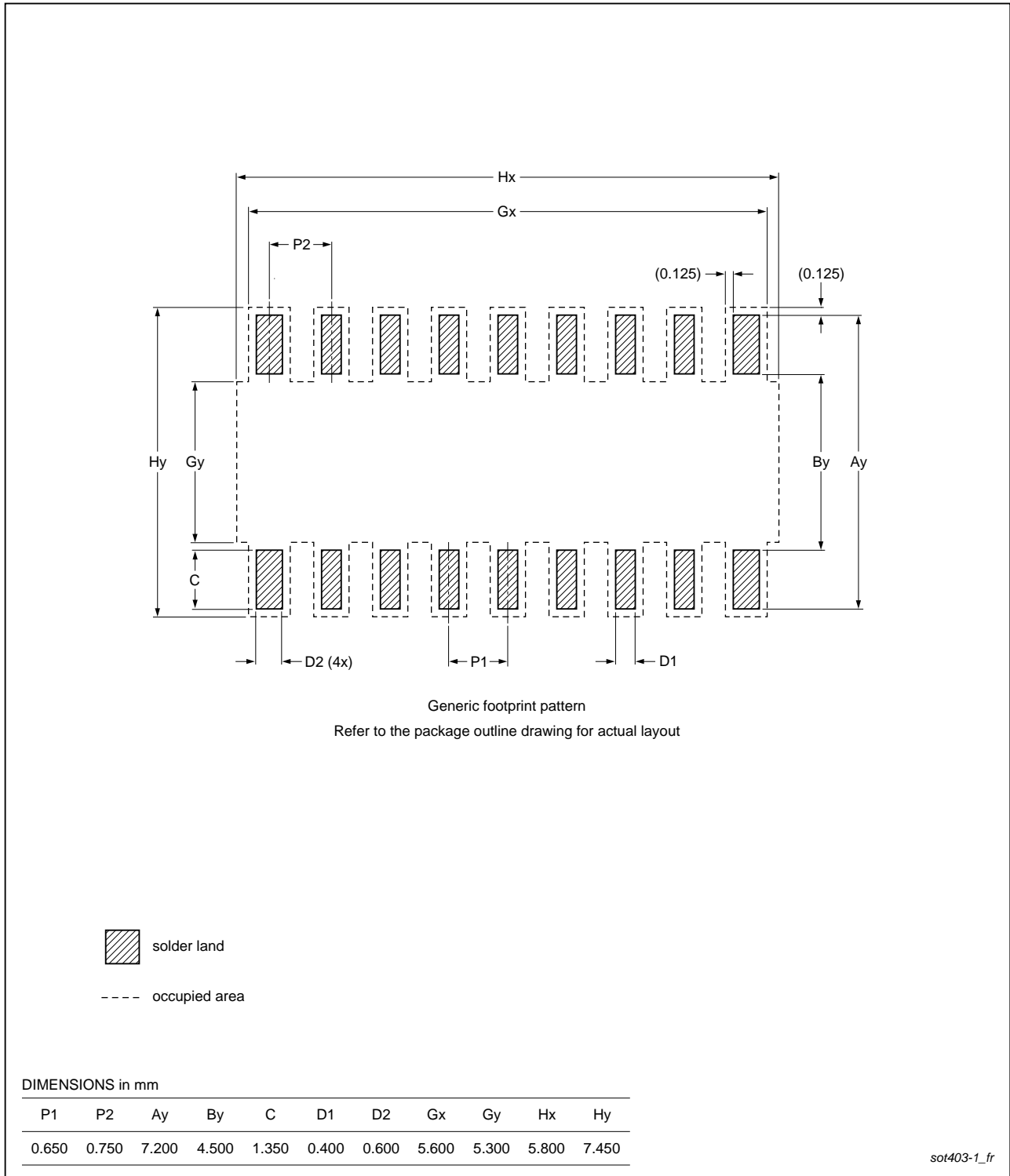

Fig 34. PCB footprint for SOT403-1 (TSSOP16); reflow soldering

19. Abbreviations

Table 20. Abbreviations

| Acronym | Description |
|----------------------|--|
| ACPI | Advanced Configuration and Power Interface |
| CBT | Cross-Bar Technology |
| CDM | Charged-Device Model |
| CMOS | Complementary Metal-Oxide Semiconductor |
| DUT | Device Under Test |
| ESD | ElectroStatic Discharge |
| FET | Field-Effect Transistor |
| FF | Flip-Flop |
| GPIO | General Purpose Input/Output |
| HBM | Human Body Model |
| I ² C-bus | Inter-Integrated Circuit bus |
| I/O | Input/Output |
| LED | Light Emitting Diode |
| LP | Low-Pass |
| LSB | Least Significant Bit |
| MSB | Most Significant Bit |
| PCB | Printed-Circuit Board |
| POR | Power-On Reset |
| PRR | Pulse Repetition Rate |
| SCR | Silicon Controlled Rectifier |
| SMBus | System Management Bus |

20. Revision history

Table 21. Revision history

| Document ID | Release date | Data sheet status | Change notice | Supersedes |
|--------------|--------------|--------------------|---------------|------------|
| PCA9538A v.1 | 20120928 | Product data sheet | - | - |

21. Legal information

21.1 Data sheet status

| Document status ^{[1][2]} | Product status ^[3] | Definition |
|-----------------------------------|-------------------------------|---|
| Objective [short] data sheet | Development | This document contains data from the objective specification for product development. |
| Preliminary [short] data sheet | Qualification | This document contains data from the preliminary specification. |
| Product [short] data sheet | Production | This document contains the product specification. |

[1] Please consult the most recently issued document before initiating or completing a design.

[2] The term 'short data sheet' is explained in section "Definitions".

[3] The product status of device(s) described in this document may have changed since this document was published and may differ in case of multiple devices. The latest product status information is available on the Internet at URL <http://www.nxp.com>.

21.2 Definitions

Draft — The document is a draft version only. The content is still under internal review and subject to formal approval, which may result in modifications or additions. NXP Semiconductors does not give any representations or warranties as to the accuracy or completeness of information included herein and shall have no liability for the consequences of use of such information.

Short data sheet — A short data sheet is an extract from a full data sheet with the same product type number(s) and title. A short data sheet is intended for quick reference only and should not be relied upon to contain detailed and full information. For detailed and full information see the relevant full data sheet, which is available on request via the local NXP Semiconductors sales office. In case of any inconsistency or conflict with the short data sheet, the full data sheet shall prevail.

Product specification — The information and data provided in a Product data sheet shall define the specification of the product as agreed between NXP Semiconductors and its customer, unless NXP Semiconductors and customer have explicitly agreed otherwise in writing. In no event however, shall an agreement be valid in which the NXP Semiconductors product is deemed to offer functions and qualities beyond those described in the Product data sheet.

21.3 Disclaimers

Limited warranty and liability — Information in this document is believed to be accurate and reliable. However, NXP Semiconductors does not give any representations or warranties, expressed or implied, as to the accuracy or completeness of such information and shall have no liability for the consequences of use of such information. NXP Semiconductors takes no responsibility for the content in this document if provided by an information source outside of NXP Semiconductors.

In no event shall NXP Semiconductors be liable for any indirect, incidental, punitive, special or consequential damages (including - without limitation - lost profits, lost savings, business interruption, costs related to the removal or replacement of any products or rework charges) whether or not such damages are based on tort (including negligence), warranty, breach of contract or any other legal theory.

Notwithstanding any damages that customer might incur for any reason whatsoever, NXP Semiconductors' aggregate and cumulative liability towards customer for the products described herein shall be limited in accordance with the *Terms and conditions of commercial sale* of NXP Semiconductors.

Right to make changes — NXP Semiconductors reserves the right to make changes to information published in this document, including without limitation specifications and product descriptions, at any time and without notice. This document supersedes and replaces all information supplied prior to the publication hereof.

Suitability for use — NXP Semiconductors products are not designed, authorized or warranted to be suitable for use in life support, life-critical or safety-critical systems or equipment, nor in applications where failure or malfunction of an NXP Semiconductors product can reasonably be expected to result in personal injury, death or severe property or environmental damage. NXP Semiconductors and its suppliers accept no liability for inclusion and/or use of NXP Semiconductors products in such equipment or applications and therefore such inclusion and/or use is at the customer's own risk.

Applications — Applications that are described herein for any of these products are for illustrative purposes only. NXP Semiconductors makes no representation or warranty that such applications will be suitable for the specified use without further testing or modification.

Customers are responsible for the design and operation of their applications and products using NXP Semiconductors products, and NXP Semiconductors accepts no liability for any assistance with applications or customer product design. It is customer's sole responsibility to determine whether the NXP Semiconductors product is suitable and fit for the customer's applications and products planned, as well as for the planned application and use of customer's third party customer(s). Customers should provide appropriate design and operating safeguards to minimize the risks associated with their applications and products.

NXP Semiconductors does not accept any liability related to any default, damage, costs or problem which is based on any weakness or default in the customer's applications or products, or the application or use by customer's third party customer(s). Customer is responsible for doing all necessary testing for the customer's applications and products using NXP Semiconductors products in order to avoid a default of the applications and the products or of the application or use by customer's third party customer(s). NXP does not accept any liability in this respect.

Limiting values — Stress above one or more limiting values (as defined in the Absolute Maximum Ratings System of IEC 60134) will cause permanent damage to the device. Limiting values are stress ratings only and (proper) operation of the device at these or any other conditions above those given in the Recommended operating conditions section (if present) or the Characteristics sections of this document is not warranted. Constant or repeated exposure to limiting values will permanently and irreversibly affect the quality and reliability of the device.

Terms and conditions of commercial sale — NXP Semiconductors products are sold subject to the general terms and conditions of commercial sale, as published at <http://www.nxp.com/profile/terms>, unless otherwise agreed in a valid written individual agreement. In case an individual agreement is concluded only the terms and conditions of the respective agreement shall apply. NXP Semiconductors hereby expressly objects to applying the customer's general terms and conditions with regard to the purchase of NXP Semiconductors products by customer.

No offer to sell or license — Nothing in this document may be interpreted or construed as an offer to sell products that is open for acceptance or the grant, conveyance or implication of any license under any copyrights, patents or other industrial or intellectual property rights.

Export control — This document as well as the item(s) described herein may be subject to export control regulations. Export might require a prior authorization from competent authorities.

Non-automotive qualified products — Unless this data sheet expressly states that this specific NXP Semiconductors product is automotive qualified, the product is not suitable for automotive use. It is neither qualified nor tested in accordance with automotive testing or application requirements. NXP Semiconductors accepts no liability for inclusion and/or use of non-automotive qualified products in automotive equipment or applications.

In the event that customer uses the product for design-in and use in automotive applications to automotive specifications and standards, customer (a) shall use the product without NXP Semiconductors' warranty of the product for such automotive applications, use and specifications, and (b) whenever customer uses the product for automotive applications beyond NXP Semiconductors' specifications such use shall be solely at customer's

own risk, and (c) customer fully indemnifies NXP Semiconductors for any liability, damages or failed product claims resulting from customer design and use of the product for automotive applications beyond NXP Semiconductors' standard warranty and NXP Semiconductors' product specifications.

Translations — A non-English (translated) version of a document is for reference only. The English version shall prevail in case of any discrepancy between the translated and English versions.

21.4 Trademarks

Notice: All referenced brands, product names, service names and trademarks are the property of their respective owners.

I²C-bus — logo is a trademark of NXP B.V.

22. Contact information

For more information, please visit: <http://www.nxp.com>

For sales office addresses, please send an email to: salesaddresses@nxp.com

23. Contents

| | | | | | |
|-----------|---|-----------|-----------|----------------------------------|-----------|
| 1 | General description | 1 | 19 | Abbreviations | 34 |
| 2 | Features and benefits | 2 | 20 | Revision history | 34 |
| 3 | Ordering information | 2 | 21 | Legal information | 35 |
| 3.1 | Ordering options | 2 | 21.1 | Data sheet status | 35 |
| 4 | Block diagram | 3 | 21.2 | Definitions | 35 |
| 5 | Pinning information | 4 | 21.3 | Disclaimers | 35 |
| 5.1 | Pinning | 4 | 21.4 | Trademarks | 36 |
| 5.2 | Pin description | 4 | 22 | Contact information | 36 |
| 6 | Functional description | 5 | 23 | Contents | 37 |
| 6.1 | Device address | 5 | | | |
| 6.2 | Pointer register and command byte | 5 | | | |
| 6.3 | Interface definition | 6 | | | |
| 6.4 | Register descriptions | 6 | | | |
| 6.4.1 | Input port register (00h) | 6 | | | |
| 6.4.2 | Output port register (01h) | 6 | | | |
| 6.4.3 | Polarity inversion register (02h) | 6 | | | |
| 6.4.4 | Configuration register (03h) | 7 | | | |
| 6.5 | I/O port | 7 | | | |
| 6.6 | Power-on reset | 8 | | | |
| 6.7 | Reset input ($\overline{\text{RESET}}$) | 8 | | | |
| 6.8 | Interrupt output (INT) | 8 | | | |
| 7 | Bus transactions | 9 | | | |
| 7.1 | Write commands | 9 | | | |
| 7.2 | Read commands | 10 | | | |
| 8 | Application design-in information | 11 | | | |
| 8.1 | Minimizing I _{DD} when the I/Os are used to control LEDs | 12 | | | |
| 8.2 | 12 V tolerant I/Os | 12 | | | |
| 8.3 | Power-on reset requirements | 13 | | | |
| 9 | Limiting values | 15 | | | |
| 10 | Recommended operating conditions | 15 | | | |
| 11 | Thermal characteristics | 15 | | | |
| 12 | Static characteristics | 16 | | | |
| 12.1 | Typical characteristics | 18 | | | |
| 13 | Dynamic characteristics | 22 | | | |
| 14 | Parameter measurement information | 23 | | | |
| 15 | Package outline | 27 | | | |
| 16 | Handling information | 29 | | | |
| 17 | Soldering of SMD packages | 29 | | | |
| 17.1 | Introduction to soldering | 29 | | | |
| 17.2 | Wave and reflow soldering | 29 | | | |
| 17.3 | Wave soldering | 29 | | | |
| 17.4 | Reflow soldering | 30 | | | |
| 18 | Soldering: PCB footprints | 32 | | | |

Please be aware that important notices concerning this document and the product(s) described herein, have been included in section 'Legal information'.

© NXP B.V. 2012.

All rights reserved.

For more information, please visit: <http://www.nxp.com>

For sales office addresses, please send an email to: salesaddresses@nxp.com

Date of release: 28 September 2012

Document identifier: PCA9538A