

PCA9450

Power management IC for i.MX 8M application processor family

Rev. 2.2 — 15 September 2021

Product data sheet

1 General description

PCA9450 is a single chip Power Management IC (PMIC) specifically designed to support i.MX 8M family processor in both 1 cell Li-Ion and Li-polymer battery portable application and 5 V adapter non-portable applications. It supports various memory types (DDR4/LPDDR4/DDR3L, etc.) via system UBOOT configuration, which does not require hardware change.

The device provides six high efficiency step-down regulators, five LDOs, one 400 mA load switch, 2-channel level translator and 32.768 kHz crystal oscillator driver. Three buck regulators support Dynamic Voltage Scaling (DVS) feature along with programmable ramping up and down time and those buck regulators support remote sense to compensate IR drop to load from buck regulator. This device is characterized across -40 °C to 105 °C ambient temperature range.

Six step-down regulators are designed to provide power for i.MX 8M application processor and DRAM memory. Two LDOs, LDO1 and LDO2, feature very low quiescent current to provide power for Secure Non-Volatile Storage (SNVS) since these LDOs are always ON when input voltage is valid.

PCA9450 integrates logic translator which is a 2-bit, dual supply translating transceiver with auto direction sensing. It enables bidirectional voltage level translation. It can be used as I²C level translator. 400 mA load switch is to supply 3.3 V power supply to SD card, which has internal discharge resistor.

PCA9450 has three versions: PCA9450AA is companion PMIC for (i.MX 8M Mini), PCA9450B is companion PMIC for i.MX 8M Nano and PCA9450C is companion PMIC for i.MX 8M Plus.

The PCA9450 is offered in 56-pin HVQFN package, 7 mm x 7 mm, 0.4 mm pitch.

2 Features and benefits

- Six high-efficiency step-down regulators
 - Three 3 A buck regulators with DVS feature and remote sense
 - PCA9450AA – Three 3 A buck regulators
 - PCA9450B – Two 3 A buck regulators
 - PCA9450C – 6 A dual-phase buck regulator and 3 A buck regulator
- One 3 A buck regulator
- Two 2 A buck regulators
- Five linear regulators
 - Two 10 mA LDOs
 - One 150 mA LDO
 - One 200 mA LDO
 - One 300 mA LDO



- Support various memory types: DDR4/LPDDR4/DDR3L via system UBOOT configuration, no hardware change required
- 400 mA load switch with built-in active discharge resistor
- 32.768 kHz crystal oscillator driver and buffer output
- Two channel logic level translator
- Power control IO
 - Power ON/OFF control
 - Standby/run mode control
- Fm+ 1 MHz I²C-bus interface
- ESD protection
 - Human Body Model (HBM) : +/- 2000 V
 - Charged Device Model (CDM) : +/-500 V
- 7 mm x 7 mm, 56-pin HVQFN with 0.4 mm pitch

3 Applications

- IoT Devices
- Tablet
- Electronic Point of Sale (ePOS)
- Industrial application

4 Ordering information

Table 1. Ordering information

Type number	Topside marking	AP platform	Package		
			Name	Description	Version
PCA9450AAHN	PCA9450AA	i.MX 8M Mini	HVQFN56	thermal enhanced very thin quad flat package; no leads; 56 terminals; 0.4 mm pitch, 7 mm x 7 mm x 0.85 mm body	SOT949-6
PCA9450BHN	PCA9450B	i.MX 8M Nano	HVQFN56	thermal enhanced very thin quad flat package; no leads; 56 terminals; 0.4 mm pitch, 7 mm x 7 mm x 0.85 mm body	SOT949-6
PCA9450CHN	PCA9450C	i.MX 8M Plus	HVQFN56	thermal enhanced very thin quad flat package; no leads; 56 terminals; 0.4 mm pitch, 7 mm x 7 mm x 0.85 mm body	SOT949-6

Table 2. Ordering options

Type number	Orderable part number	Package	Packing method	Minimum order quantity	Temperature range (T _{amb})	Recommended temperature range (T _J)
PCA9450AAHN	PCA9450AAHNY	HVQFN56	REEL 13" Q1 DP	2000	-40 °C to +105 °C	-40 °C to +125 °C
PCA9450BHN	PCA9450BHNY	HVQFN56	REEL 13" Q1 DP	2000	-40 °C to +105 °C	-40 °C to +125 °C
PCA9450CHN	PCA9450CHNY	HVQFN56	REEL 13" Q1 DP	2000	-40 °C to +105 °C	-40 °C to +125 °C

5 Block diagram

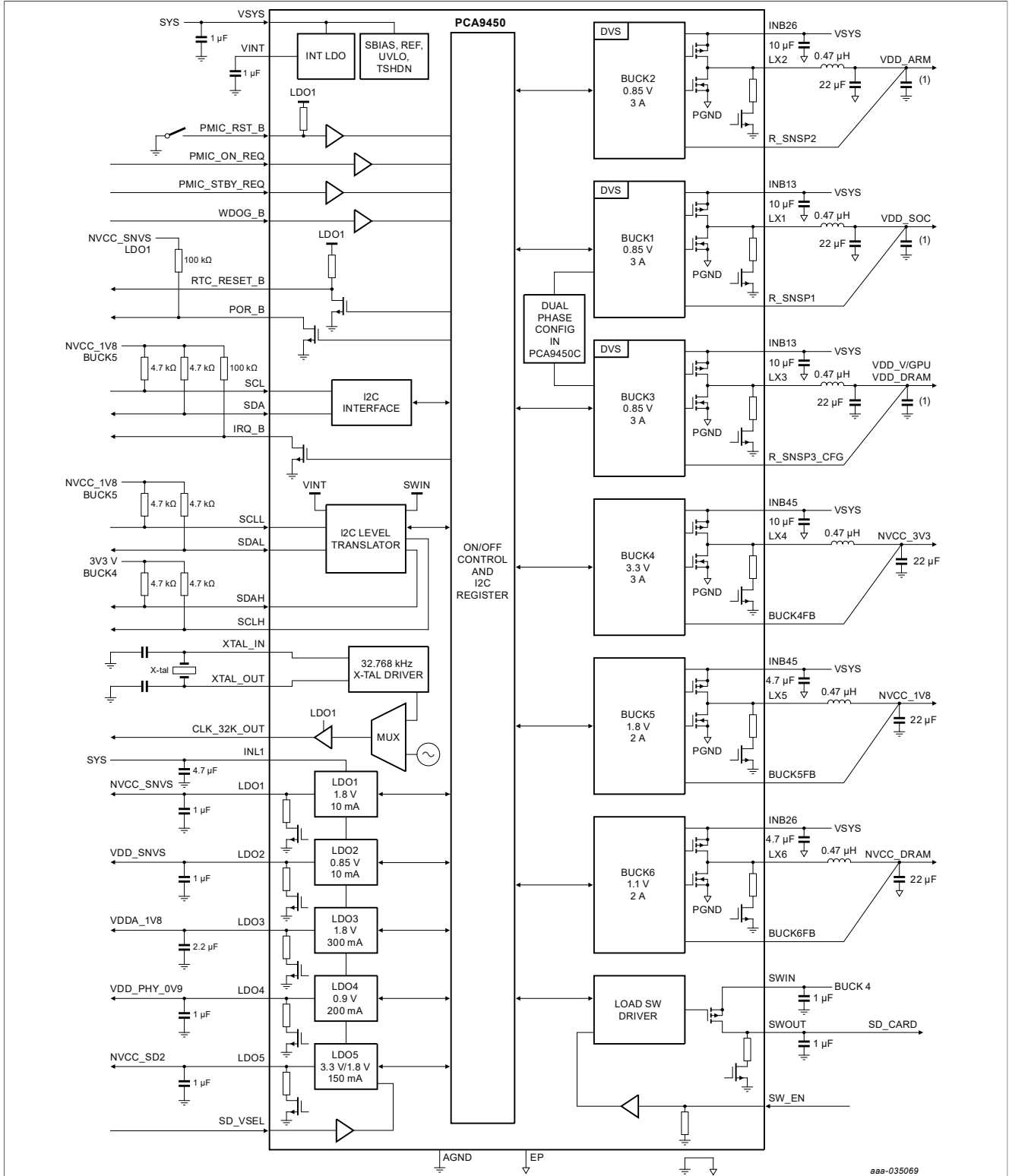

(1) This capacitor is decoupling capacitor in MCU side.

Figure 1. Block diagram

6 Pinning information

6.1 Pinning

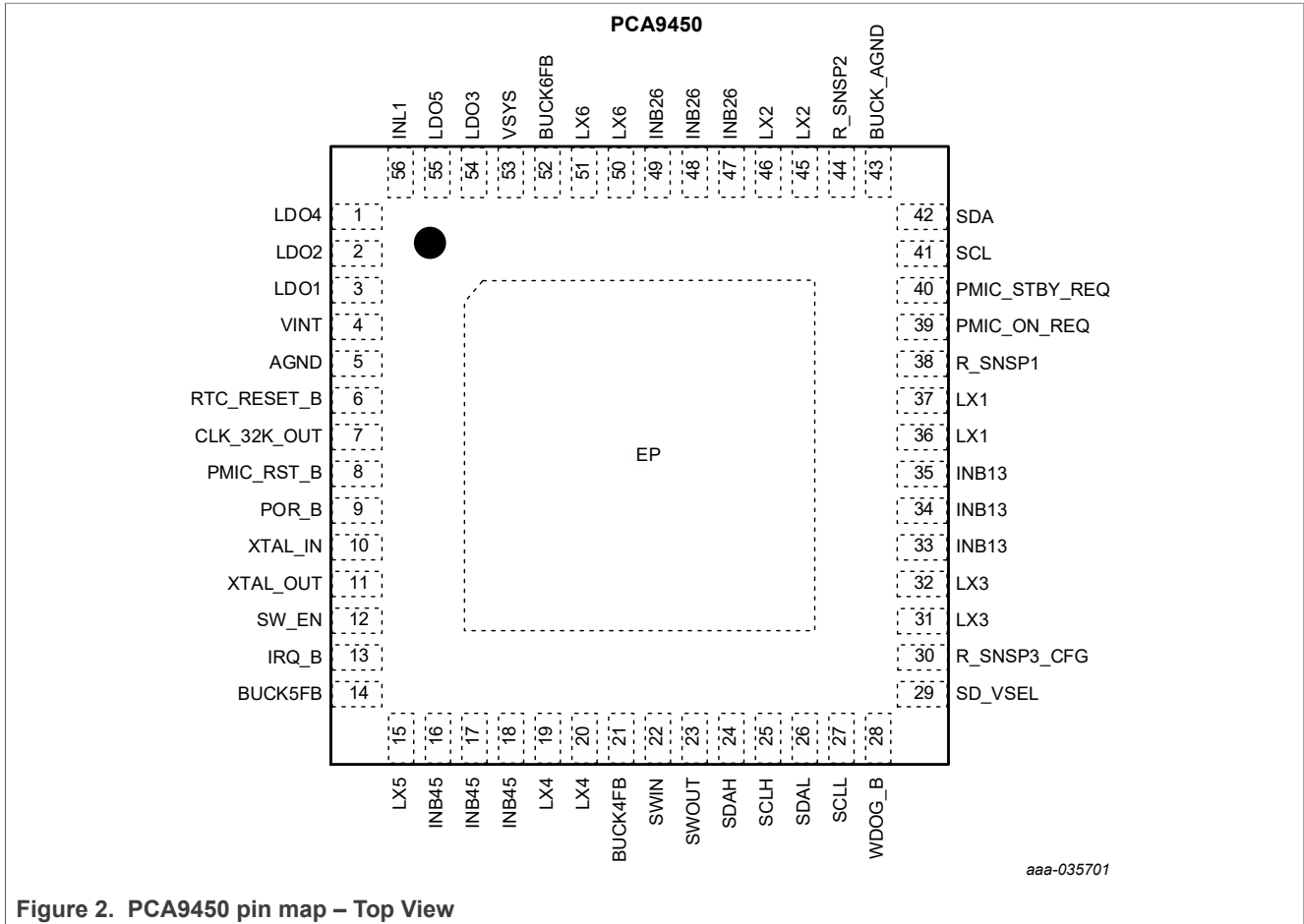

Figure 2. PCA9450 pin map – Top View

6.2 Pin description

Table 3. Pin description

Pin description			
Symbol	Pin	Type	Description
LDO4	1	P	LDO4 output. Bypass with a 1 μ F to Ground.
LDO2	2	P	LDO2 output. Bypass with a 1 μ F to Ground.
LDO1	3	P	LDO1 output. Bypass with a 1 μ F to Ground.
VINT	4	P	Internal Power supply output pin. Bypass with 1 μ F to Ground.
AGND	5	GND	Analog ground pin. It should be connected to ground plane through Via. Do not short to EP directly on top layer

Table 3. Pin description...continued

Pin description			
Symbol	Pin	Type	Description
RTC_RESET_B	6	DO	Reset output pin. It is High-Z after both LDO1 and LDO2 voltage are good. It is internally pulled up with LDO1 power rail
CLK_32K_OUT	7	DO	32.768 kHz clock CMOS output with LDO1 power rail.
PMIC_RST_B	8	DI	PMIC reset input pin. It is internally pulled up with LDO1 power rail. Once it is asserted low, PMIC performs reset.
POR_B	9	DO	Power On reset output pin. Open drain output requiring external pull up resistor.
XTAL_IN	10	AI	32.768 kHz crystal oscillator input, tie to GND if X-tal is not used
XTAL_OUT	11	AO	32.768 kHz crystal oscillator output, leave floating if X-tal is not used
SW_EN	12	DI	Load switch enable input pin. It has internal 1.5 M Ω pull down resistor.
IRQ_B	13	DO	Open drain output to indicate Interrupt issued. It requires external pull up resistor.
BUCK5FB	14	AI	BUCK5 output voltage sensing pin. If BUCK5 is not used, tie to INB45.
LX5	15	P	BUCK5 switching node. If BUCK5 is not used, leave it floating.
INB45	16,17,18	P	BUCK4 / BUCK5 Input pins. Bypass with 10 μ F and 4.7 μ F to Ground
LX4	19,20	P	BUCK4 switching node. If BUCK4 is not used, leave them floating.
BUCK4FB	21	AI	BUCK4 output voltage sensing pin. If BUCK4 is not used, tie to INB45.
SWIN	22	P	Load switch input pin. Bypass with a 1 μ F to Ground. Leave it floating if not used (must connect to BUCK4, 3.3 V, if I ² C level translator is used).
SWOUT	23	P	Load switch output pin. Bypass with a 1 μ F to Ground. Leave it floating if not used.
SDAH	24	DIO	Level translator high voltage IO pin, SDA referenced to SWIN, 3.3 V
SCLH	25	DO	Level translator high voltage IO pin, SCL referenced to SWIN, 3.3 V
SDAL	26	DIO	Level translator low voltage IO pin, SDA referenced to VINT, 1.8 V
SCLL	27	DO	Level translator low voltage IO pin, SCL referenced to VINT, 1.8 V
WDOG_B	28	DI	Active low watchdog reset input pin from application processor.

Table 3. Pin description...continued

Pin description			
Symbol	Pin	Type	Description
SD_VSEL	29	DI	LDO5 voltage selection input pin. LDO5 output is 3.3 V when it is driven low and 1.8 V when driven high. VSEL pin should be tied low or high. Do not leave it floating.
R_SNSP3_CFG	30	AI	BUCK3 output voltage remote sense pin in PCA9450AA. Logic input pin in PCA9450B/C. This pin should be tied to SYS in PCA9450B, where BUCK3 is disabled. This pin is tied to GND in PCA9450C, where BUCK1 and BUCK3 are configured as dual phase buck regulator.
LX3	31,32	P	BUCK3 switching node If BUCK3 is not used by shorting R_SNSP3_CFG to VSYS, leave LX3 pins floating.
INB13	33,34,35	P	BUCK1 / BUCK3 Input. Bypass with two 10 μ F to Ground
LX1	36,37	P	BUCK1 switching node. Leave it floating if not used.
R_SNSP1	38	AI	BUCK1 output voltage remote sensing pin. Tie to INB13 if not used.
PMIC_ON_REQ	39	DI	PMIC ON input from Application processor. When it is asserted high, the device starts power on sequence.
PMIC_STBY_REQ	40	DI	Standby mode input from Application processor. When it is asserted high, device enters STANDBY mode.
SCL	41	DI	I2C serial clock pin
SDA	42	DIO	I2C serial data pin
BUCK_AGND	43	GND	Buck reference GND for BUCK1,2,3. It should be connected to ground plane through Via. Do not short to EP directly on top layer
R_SNSP2	44	AI	BUCK2 output voltage remote sensing pin. Tie to INB26 if not used.
LX2	45,46	P	BUCK2 switching node. Leave them floating if not used.
INB26	47,48,49	P	BUCK2 / BUCK6 Input. Bypass with 10 μ F and 4.7 μ F to Ground
LX6	50,51	P	BUCK6 switching node. Leave it floating if not used.
BUCK6FB	52	AI	BUCK6 output voltage sensing pin. Tie to INB26 if not used.
VSYS	53	P	Internal power input. Bypass with a 1 μ F to Ground
LDO3	54	P	LDO3 output. Bypass with a 2.2 μ F to Ground.
LDO5	55	P	LDO5 output. Bypass with a 1 μ F to Ground.
INL1	56	P	Power input pin for LDO1, LDO2, LDO3, LDO4 and LDO5. Bypass with a 4.7 μ F to Ground.
EP		GND	Exposed PAD. All buck PGNDs are internally connected.

7 Functional description

7.1 Features

The PCA9450 is a power management integrated circuit (PMIC) designed to be the primary power management for NXP application processors, i.MX 8M Mini, Nano and Plus.

- Buck regulators
 - BUCK1, BUCK2, BUCK3 : 0.6 V to 2.1875 V, 12.5 mV step, 3000 mA
 - BUCK4 : 0.6 V to 3.4 V, 25 mV step, 3000 mA
 - BUCK5, BUCK6 : 0.6 V to 3.4 V, 25 mV step, 2000 mA
 - Dynamic Voltage scaling on BUCK1, BUCK2 and BUCK3
 - Support remote sensing on BUCK1, BUCK2 and BUCK3
 - BUCK1-BUCK3 configurable as a 6 A dual phase regulator (PCA9450C)
 - Monitor fault condition
- LDO regulators
 - LDO1, 1.6 V to 1.9 V, 3.0 V to 3.3 V 100 mV step, 10 mA
 - LDO2, 0.8 V to 1.15 V with 50 mV step, 10 mA
 - LDO3, 0.8 V to 3.3 V with 100 mV step, 300 mA
 - LDO4, 0.8 V to 3.3 V with 100 mV step, 200 mA
 - LDO5, 0.8 V to 3.3 V with 100 mV step, 150 mA, Voltage selection through SD_VSEL pin
 - Monitor fault condition
- Support various memory types: DDR4/LPDDR4/DDR3L via system UBOOT configuration, no hardware change required
- 400 mA Load switch for SD card
 - Built-in OCP protection
 - GPIO/I2C control
 - Built-in Active discharge resistor
- Two Channel logic level translator
- 32.768 kHz Crystal Oscillator driver
 - Mux output with internal 32 kHz output
- Protection and Monitoring: Soft start, Power Rails Fault detection, UVLO, Thermal Shutdown
- Configurable reset behavior from WDOGB, PMIC_RST_B and SW_RST Register
- Power control IO
 - PMIC_ON_REQ, PMIC_STBY_REQ
- Fm+ 1 MHz I²C-bus interface
- Type3 PCB applicable

7.2 Functional diagram

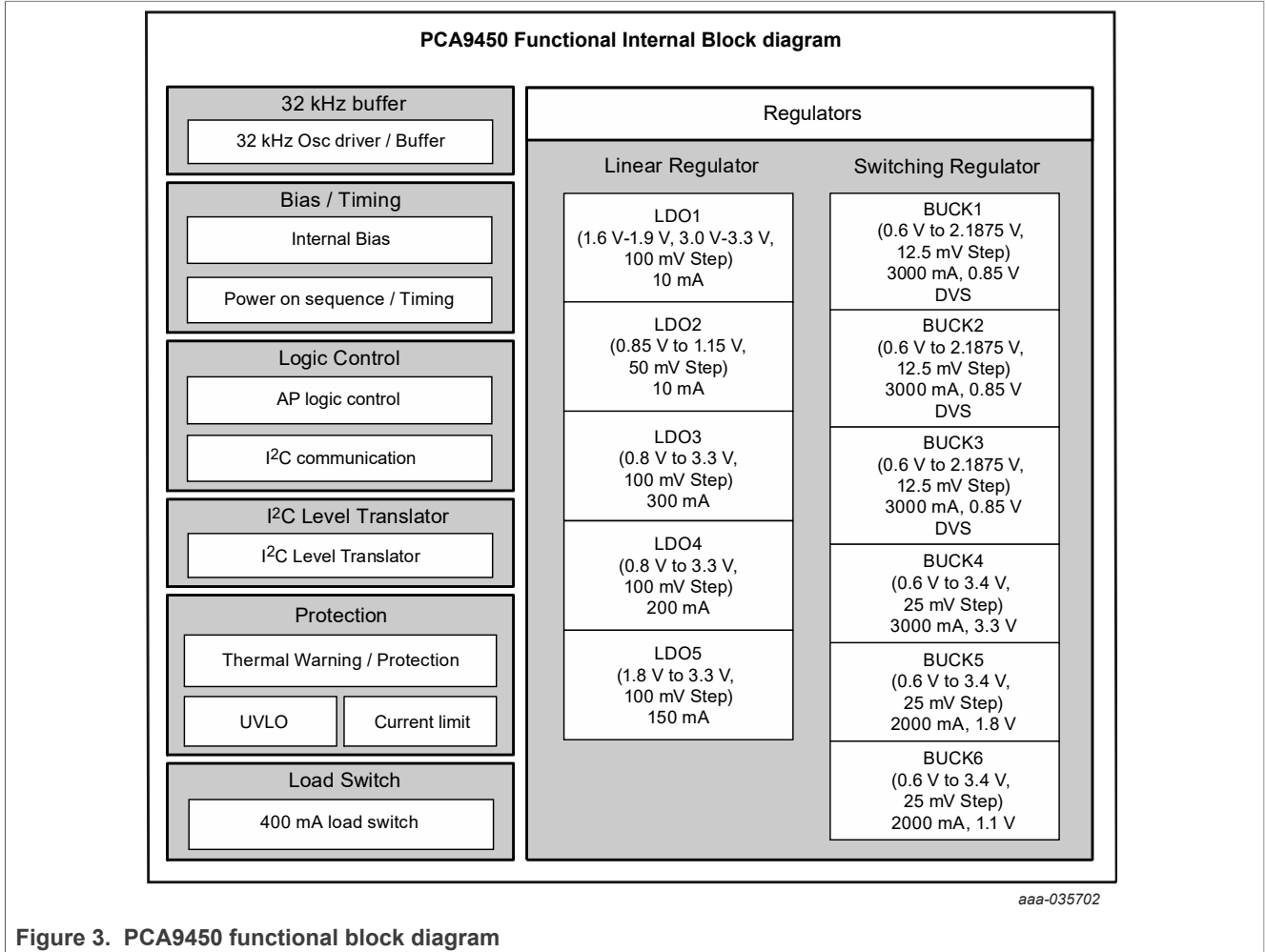

Figure 3. PCA9450 functional block diagram

The PCA9450 is a single chip Power Management IC (PMIC) specifically designed to support i.MX 8M family processor in both 1 cell Li-Ion and Li-polymer battery portable application and 5 V adapter non-portable applications.

PCA9450 is provided in three versions: PCA9450AA, PCA9450B and PCA9450C depending on target application processor. [Table 4](#) shows the selection guide.

Table 4. PCA9450 selection guide

Part number	AP Platform	BUCK1	BUCK3	LDO4	R_SNSP3_CFG
PCA9450AA	i.MX 8M Mini	3 A for SOC (ON by default)	3 A for VPU/GPU/ DRAM (ON by default)	0.9 V for VDDA (ON by default)	R_SNSP3_CFG is feedback of BUCK 3
PCA9450B	i.MX 8M Nano	3 A for SOC / VPU/GPU/DRAM (ON by default)	Disabled	OFF by default	R_SNSP3_CFG = VSYS
PCA9450C	i.MX 8M Plus	6 A Dual phase for SOC/VPU/GPU/ DRAM (ON by default)		OFF by default	R_SNSP3_CFG = GND

7.3 Power modes

PCA9450 has eight power modes: OFF, READY, SNVS, RUN, STADNBY, PWRDN, PWRUP and FAULT_SD. Figure 4 shows the state transition diagram showing the conditions to enter and exit each state.

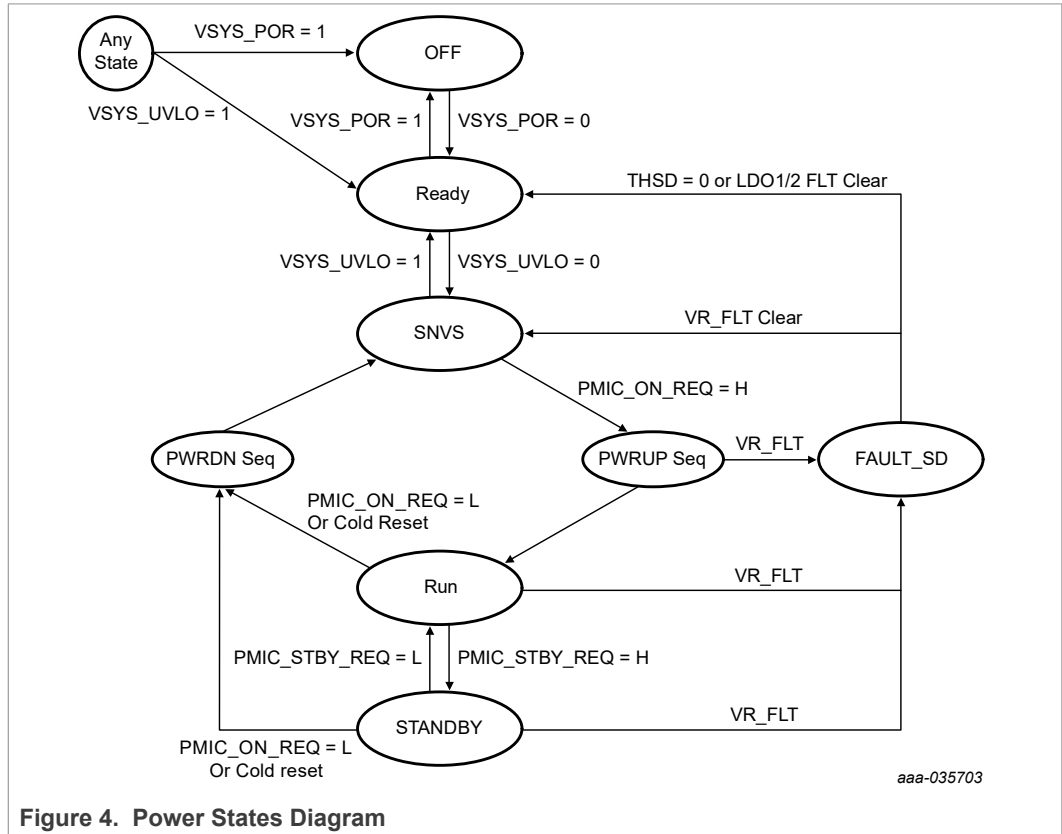

7.3.1 Off mode

PCA9450 enters OFF mode from any state when VSYS falls below V_{SYS_POR} threshold. All regulators are off and all registers get reset in this mode.

7.3.2 READY mode

PCA9450 enters READY mode from OFF mode when VSYS is higher than V_{SYS_POR} . Internal LDO VINT is enabled and loads Multiple Time Program (MTP) data to registers. Once MTP loading is done, it is ready to transition to SNVS mode.

7.3.3 SNVS mode

PCA9450 enters Secure Non-Volatile Storage mode (SNVS) when VSYS exceeds V_{SYS_UVLO} threshold. LDO1 and LDO2 are powered up and 32.768 kHz buffer starts running. RTC_RESET_B is pulled high in t_{RTC_RST} after both LDO1 and LDO2 voltage come up.

PMIC_ON_REQ input is masked until RTC_RESET_B is released. PCA9450 starts power up sequence if PMIC_ON_REQ is asserted high in this mode.

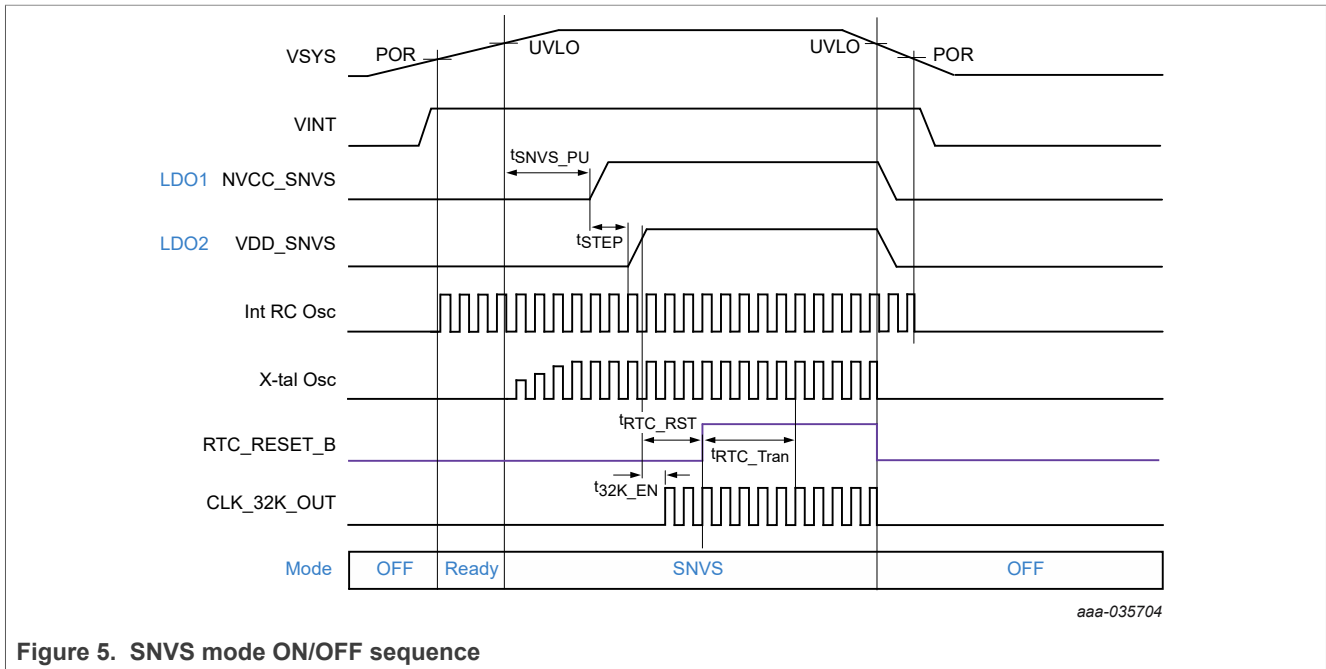

Figure 5. SNVS mode ON/OFF sequence

Table 5. SNVS mode

Time	Description	Value
t _{SNVS_PU}	Time to LDO1 turn on from VSYS UVLO detected	20 ms
t _{STEP}	Time to LDO2 ON from LDO1 POK	2 ms
t _{RTC_RST}	Time to RTC_RESET_B release from LDO2 POK	20 ms
T _{32K_EN}	Time to 32k buffer Enable from LDO2 POK	10 ms
t _{RTC_Tran}	Time to transition to Xtal output from RC osc after RTC_RESET_B release	1 sec

7.3.4 PWRUP mode

After RTC_RESET_B is released in SNVS mode, it starts power up with pre-defined sequence when PMIC_ON_REQ is asserted high for longer than debounce time, t_{ON_DEB}, which is programmable in PWR_CTRL reg. BUCK1 begins turning ON at first and then each power rail is followed with t_{step} after POK of predecessor power rail. During PWRUP mode, PMIC_STBY_REQ signal is masked until POR_B is released. The PWRUP mode ends up releasing POR_B and PCA9450 is transitioned to RUN mode. [Figure 6](#) shows Power on sequence of PCA9450AA.

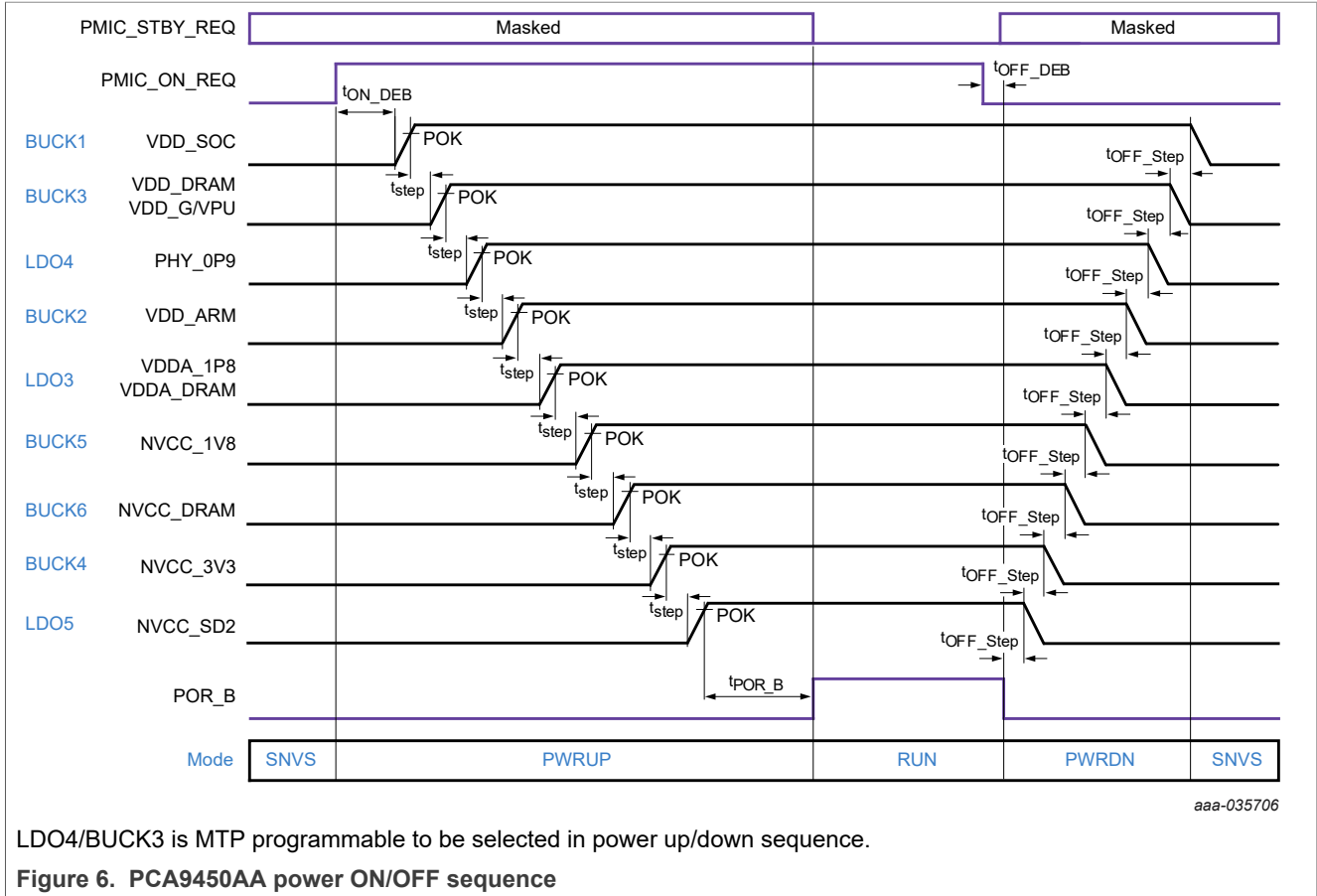

BUCK3 and LDO4 are OFF by default in PCA9450B and PCA9450C. Those regulators are removed in the power up sequence, shown in [Figure 7](#).

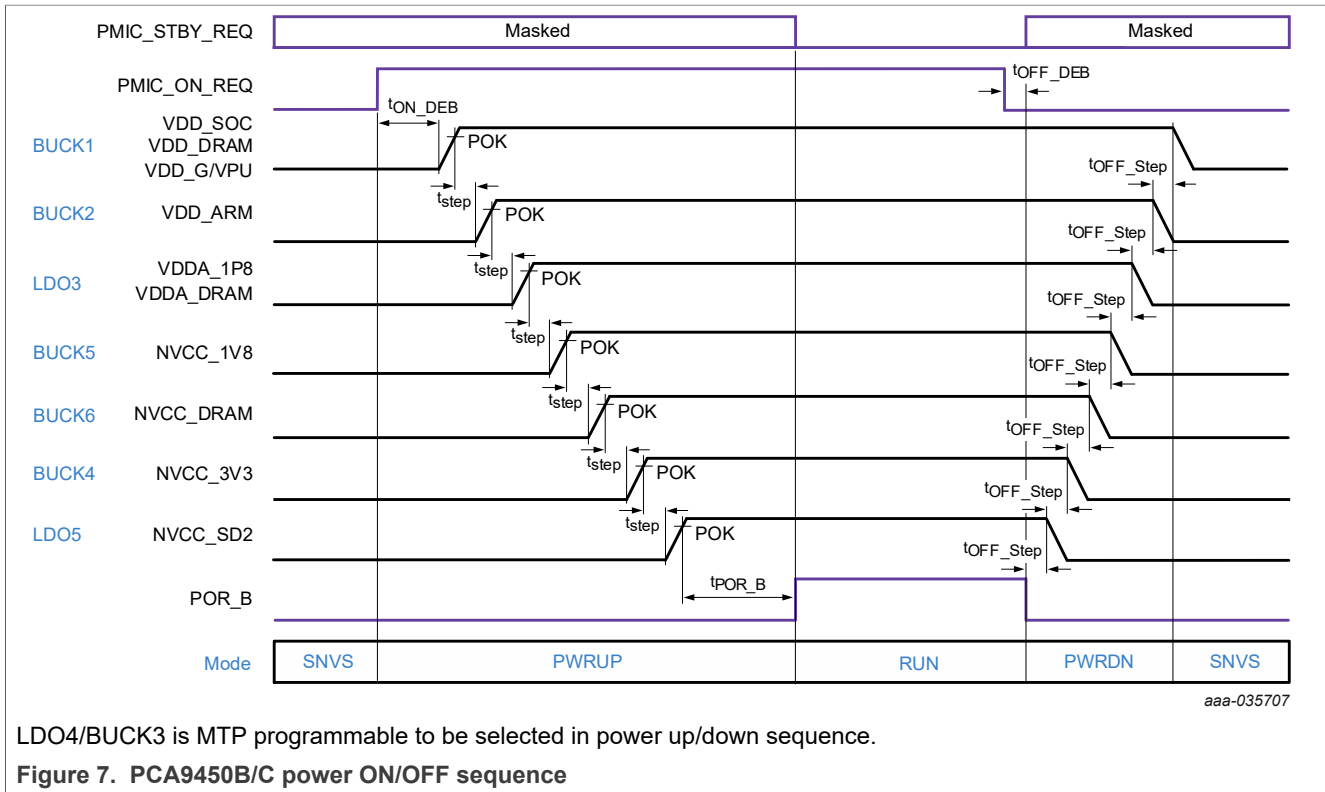

Table 6. PWRUP mode

Time	Description	Value
t_{ON_DEB}	Time to power-on start from PMIC_ON_REQ high	20 ms
t_{STEP}	Time to next power rail ON from prev rail POK	2 ms
t_{PORB}	Time to POR_B release from the last rail POK	20 ms
t_{OFF_STEP}	Time to next power rail off from prev rail off	8 ms
t_{OFF_DEB}	Time to POR_B low from PMIC_ON_REQ falling	120 μ s

If any of regulators doesn't generate POK within $t_{FLT_SH_PU}$ after receiving digital enable during PWRUP mode, it is transitioned to Fault_SD mode.

7.3.5 PWRDN mode

When PMIC_ON_REQ is low for t_{OFF_DEB} in RUN or STANDBY mode, PCA9450 enters PWRDN mode. It starts with pulling down POR_B and then turning off each power rail in t_{OFF_STEP} and transitions to SNVS mode.

7.3.6 RUN mode

PCA9450 operates in RUN mode when PMIC_ON_REQ is driven high and PMIC_STBY_REQ is driven low. BUCK1, BUCK2 and BUCK3 output voltage are set to BUCK1OUT_DVS0, BUCK2OUT_DVS0 and BUCK3OUT_DVS0 register value, respectively, when PRESET_EN bit in DVS123_DVS register is set to "0". When

PMIC_STBY_REQ is asserted high in this mode, it is transitioned to STANDBY mode.
 PMIC_ON_REQ is asserted low, it moves to PWRDN mode.

7.3.7 STANDBY mode

PCA9450 transitions to STANDBY mode from RUN mode when both PMIC_ON_REQ and PMIC_STBY_REQ are driven high. BUCK1 and BUCK3 output voltage is set to BUCK1OUT_DVS1 and BUCK3OUT_DVS1 and BUCK2 are turned off when DVS_CTRL bit in each BUCKx_CTRL register is configured to 1.

If PMIC_ON_REQ is asserted low, then it transitions to PWRDN mode. If PMIC_STBY_REQ is driven low, then it transitions to RUN mode.

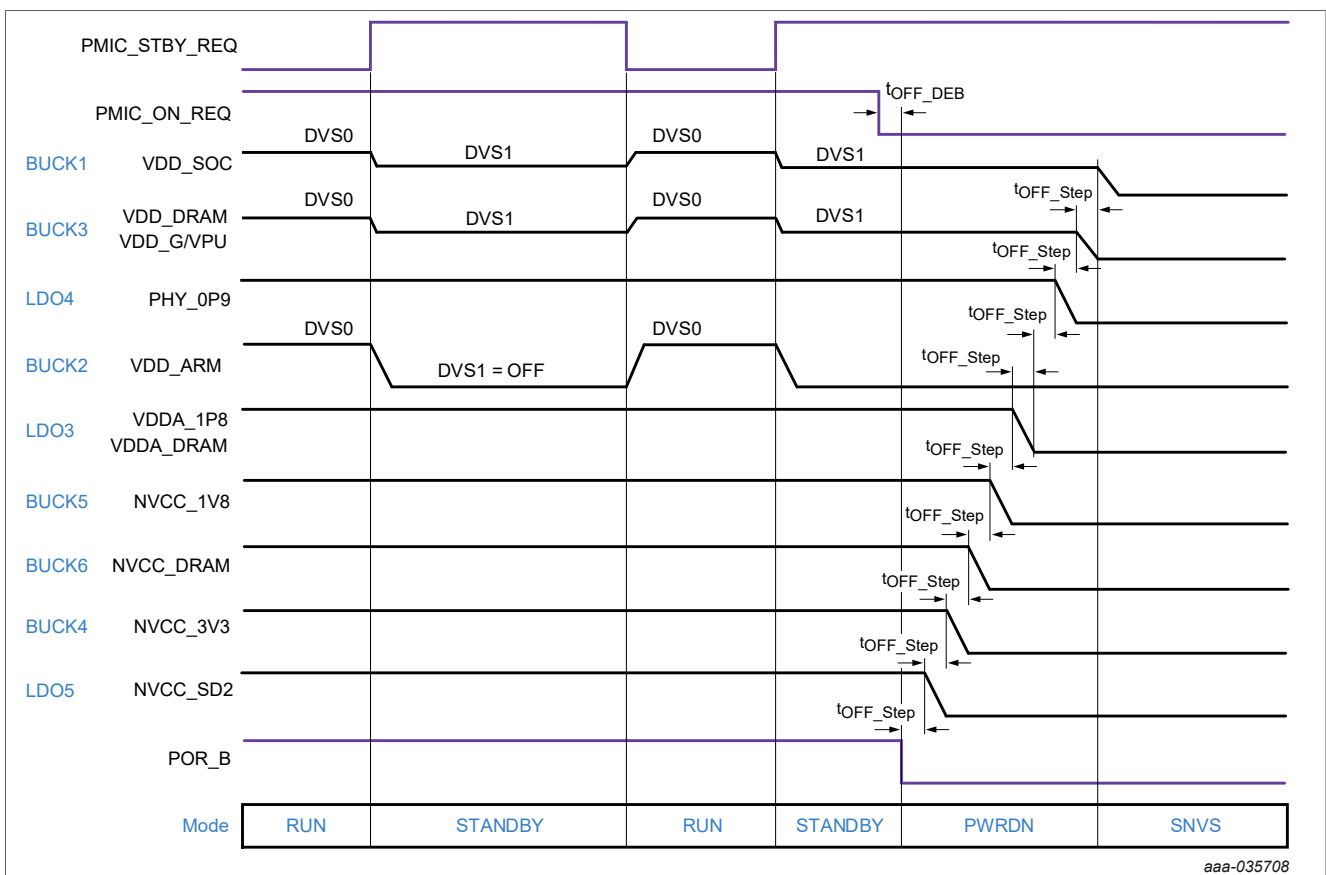

Figure 8. PCA9450AA mode transition

Table 7. Power modes summary

X : Don't care

Power mode	VSYS	PMIC_ON_REQ	PMIC_STBY_REQ
OFF	VSYS < V _{SYS_POR}	X	X
READY	VSYS > V _{SYS_POR}	X	X
SNVS	VSYS > V _{SYS_UVLO}	Low	X
STANDBY	VSYS > V _{SYS_UVLO}	High	High

Table 7. Power modes summary...continued

X : Don't care

Power mode	VSYS	PMIC_ON_REQ	PMIC_STBY_REQ
RUN	$V_{SYS} > V_{SYS_UVLO}$	High	Low

7.3.8 FAULT_SD

PCA9450 has three types of fault sources.

1. **Thermal shutdown** : Transition to SNVS mode or READY mode after FAULT_SD mode.

When junction temperature reaches T_{JSHDN} , it enters FAULT_SD mode after t_{FLT_THSD} where regulators are turned off simultaneously. It stays at FAULT_SD until junction temperature falls below T_{JSHDN} . If the temperature drops below T_{JSHDN} , then it moves to READY state if any of LDO1 and LDO2 fault is triggered when thermal shutdown

happens, and it moves to SNVS mode if neither LDO1 or LDO2 fault is triggered when thermal shutdown happens.

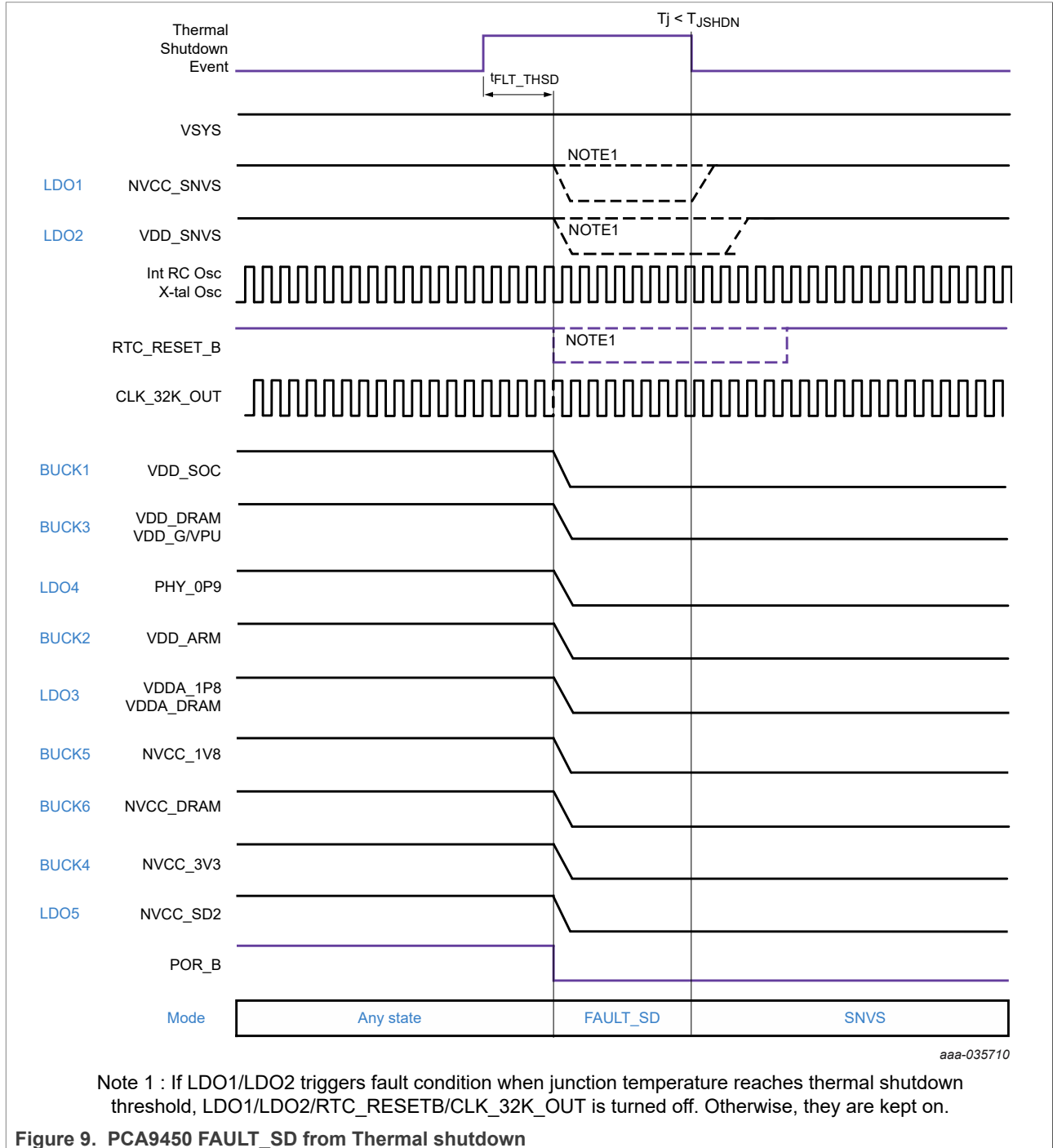

Table 8. t_{FLT_THSD}

Time	Description	Value
t_{FLT_THSD}	Time to reset released from Fault event	120 μ s

2. **Voltage regulator fault during power up:** Transition to READY mode after FAULT_SD mode.
 Any POK of voltage regulators doesn't come up within $t_{FLT_SD_PU}$ after regulator is enabled during power up sequence. It stops power-up sequence and then moves to FAULT_SD where all regulators are turned off. It stays at FAULT_SD for $t_{FLT_SD_STAY}$ and transitions to READY state.
3. **Voltage regulator fault in STANDBY and RUN MODE:** Move to FAULT_SD mode in $t_{FLT_SD_WAIT}$ after Fault is detected. Transition to SNVS mode or READY mode from FAULT_SD mode when fault is removed.
 During RUN and STANDBY mode, VR Fault status bit in VRFLT1_STS and VRFLT2_STS registers is latched to "1" when corresponding regulator voltage falls below POK threshold for t_{DEB_POKB} , or POK doesn't go high within $t_{FLT_POK_MSK}$ after regulator is enabled.
 If the fault status bit is masked in VRFLT1_MASK and VRFLT2_MASK registers, it doesn't enter FAULT_SD mode. Instead, PCA9450 stays at current mode. If the fault register bit is unmasked, it starts $t_{FLT_SD_WAIT}$ timer. Application processor can determine to enter FAULT_SD mode or not, by masking the VR Fault status bit in VRFLTx_MASK registers before the timer expires. PCA9450 enters FAULT_SD mode when the timer expires. PCA9450 stays in FAULT_SD mode for $t_{FLT_SD_STAY}$.

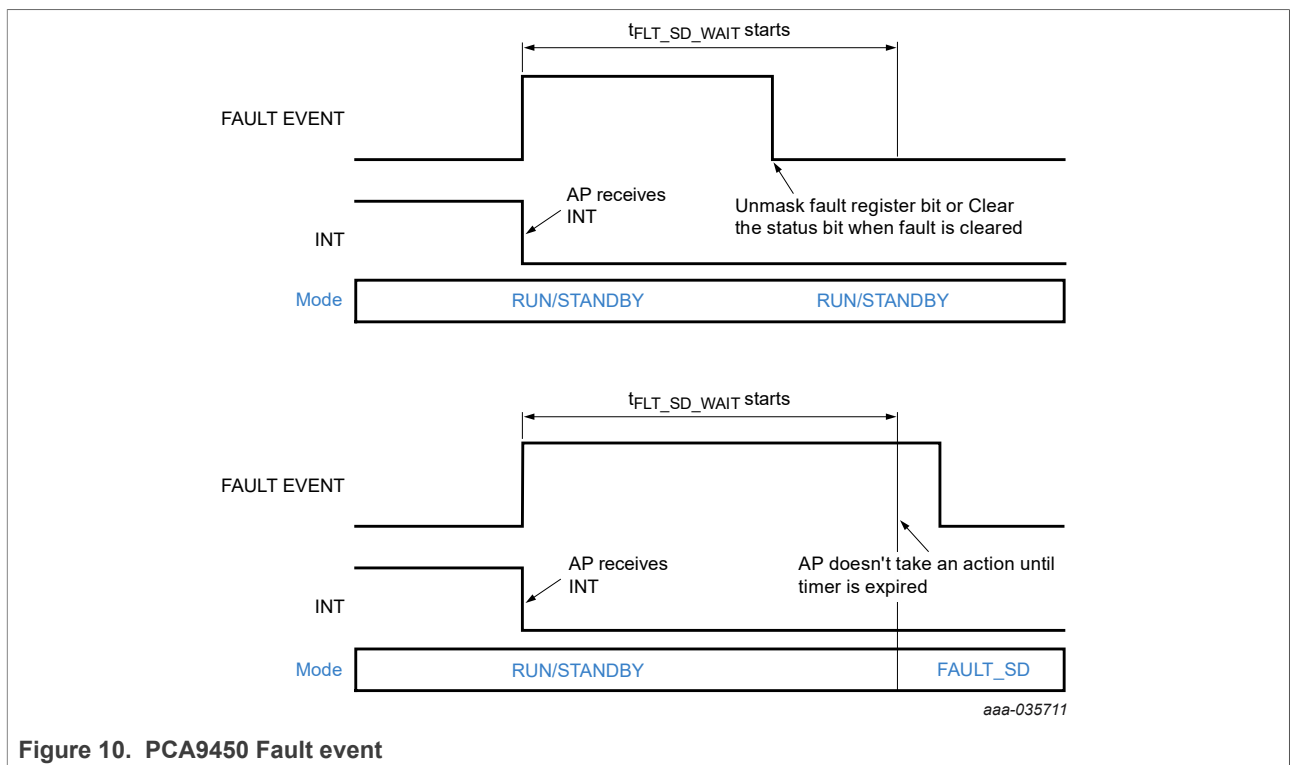

Figure 10. PCA9450 Fault event

PCA9450 moves to READY mode after FAULT_SD mode if the regulator fault is caused by LDO1 or LDO2. Otherwise, it moves to SNVS mode after FAULT_SD.

If either LDO1 or LDO2 has fault in SNVS mode, then it enters FAULT_SD mode regardless of VRFLT1 Mask bit.

PCA9450 doesn't enter FAULT_SD mode from load switch overcurrent fault.

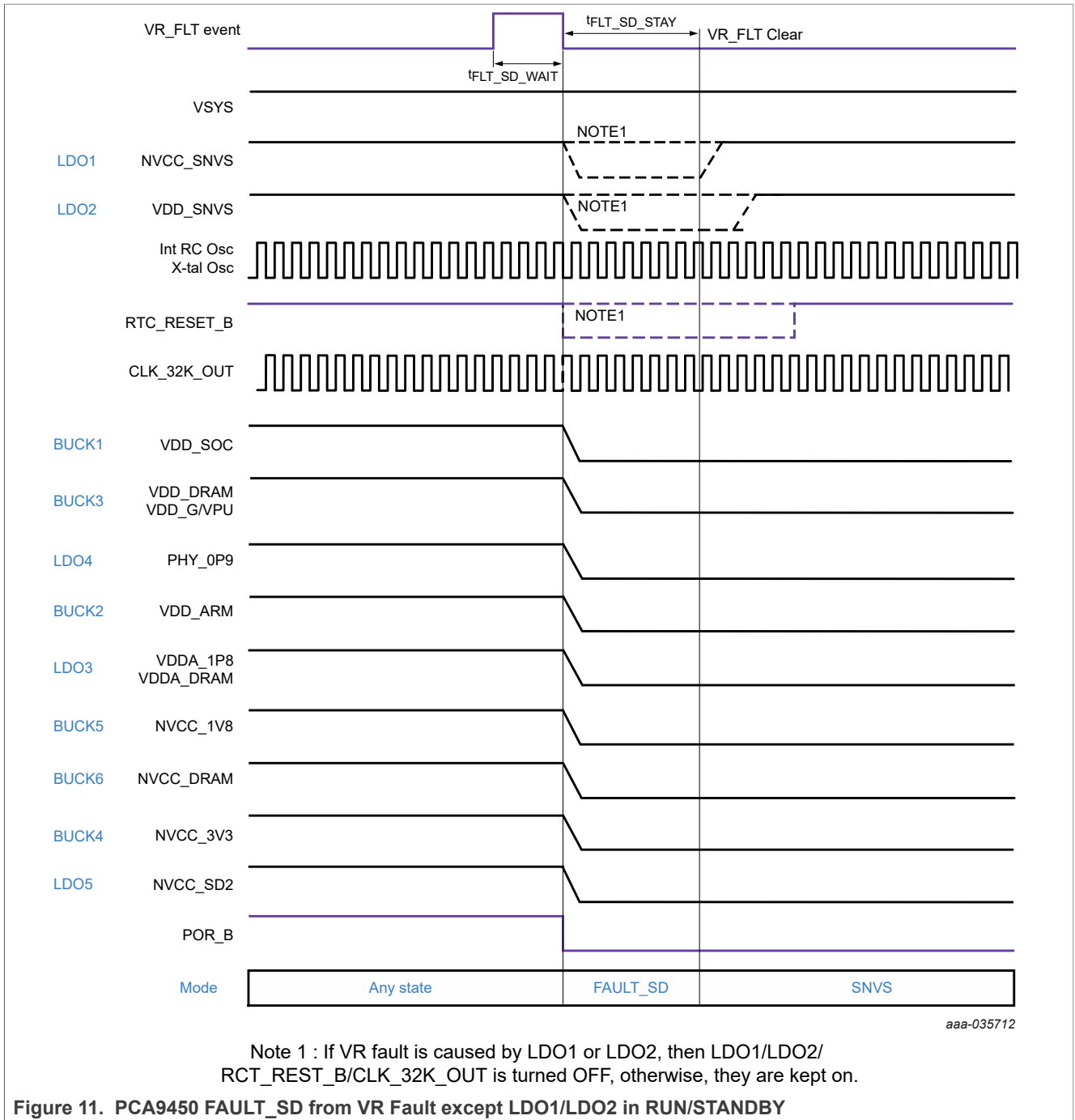

Table 9. t_{FLT_SD_WAIT}

Time	Description	Value
t _{FLT_SD_WAIT}	Time to reset released from Fault event	100 ms

7.4 PMIC reset

PCA9450 has three reset input sources: WDOG_B pin, PMIC_RST_B pin and I2C reset bit.

The reset behavior is configured in RESET_CTRL register for WDOG_B pin and PMIC_RST_B pin. I2C reset behavior is configured in SW_RST register.

Table 10. 0x08 – RESET_CTRL

0x08 – RESET_CTRL				Reset Type	S
Bit	Name	Type	Reset	Description	
7:6	WDOG_B_CFG	R/W	00	When WDOG_B is asserted to L, PMIC behavior 00b = WDOG_B reset is disabled 01b = Warm Reset, POR_B pin is asserted low for 20 ms 10b = Cold Reset, All voltage regulators are recycled except LDO1/LDO2 11b = Cold Reset, All voltage regulators are recycled	
5:4	PMIC_RST_CFG	R/W	10	When PMIC_RST_B is asserted to L, PMIC behavior 00b = PMIC_RST_B reset is disabled 01b = Warm Reset, POR_B pin is asserted low for 20 ms 10b = Cold Reset, All voltage regulators are recycled except LDO1/LDO2 11b = Cold Reset, All voltage regulators are recycled	

Table 11. 0x06 – SW_RST

0x06 – SW_RST				Reset Type	O
Bit	Name	Type	Reset	Description	
7:0	SW_RST	R/W	0x00	Software reset register. This register read back to “0x00” right after writing the value. 0x00 = No action 0x05 = Reset all registers to default value 0x14 = Cold reset (Power recycle all regulators except LDO1, LDO2 and CLK_32K_OUT) 0x35 = Warm Reset (Toggle POR_B for 20 ms) 0x64 = Cold reset (Power recycle all regulators) Others = No action	

WDOG_B is asserted low, and gets reset depending on WDOG_B_CFG bit configuration. When the bits are set to 2b00, the reset by WDOG_B pin is disabled. If the bits are set to 2b01, warm reset is performed, where POR_B is pulled low for 20 ms and resets I2C O type registers to default value keeping power rails remaining ON. If the bits are set to 2b11, it performs Cold reset, where all voltage regulators except LDO1 and LDO2 are power recycled and I2C O type registers get reset to default value.

When PMIC_RST_B is asserted low, it also gets reset depending on PMIC_RST_CFG bits configuration. When the bits are set to 2b00, any reset by PMIC_RST_B pin is disabled. If the bits are set to 2b01, warm reset is performed, in which pulling POR_B low for 20 ms and reset I2C O type registers to default value keeping power rails remaining ON.

Cold reset event is generated by either of I2C reset, WDOG_B falling edge or PMIC_RST_B falling edge after debounce time. Once it is detected, POR_B is pulled low and takes power down sequence. For cold reset from WDOG_B and I2C reset, PCA9450 stays at RESET for $t_{RESTART}$ and then starts power on sequence even though WDOG_B pin is still low. For cold reset from PMIC_RST_B, $t_{RESTART}$ timer starts after PMIC_RST_B is asserted high; in other words, PCA9450 starts power on sequence in $t_{RESTART}$ after PMIC_RST_B pin is released high.

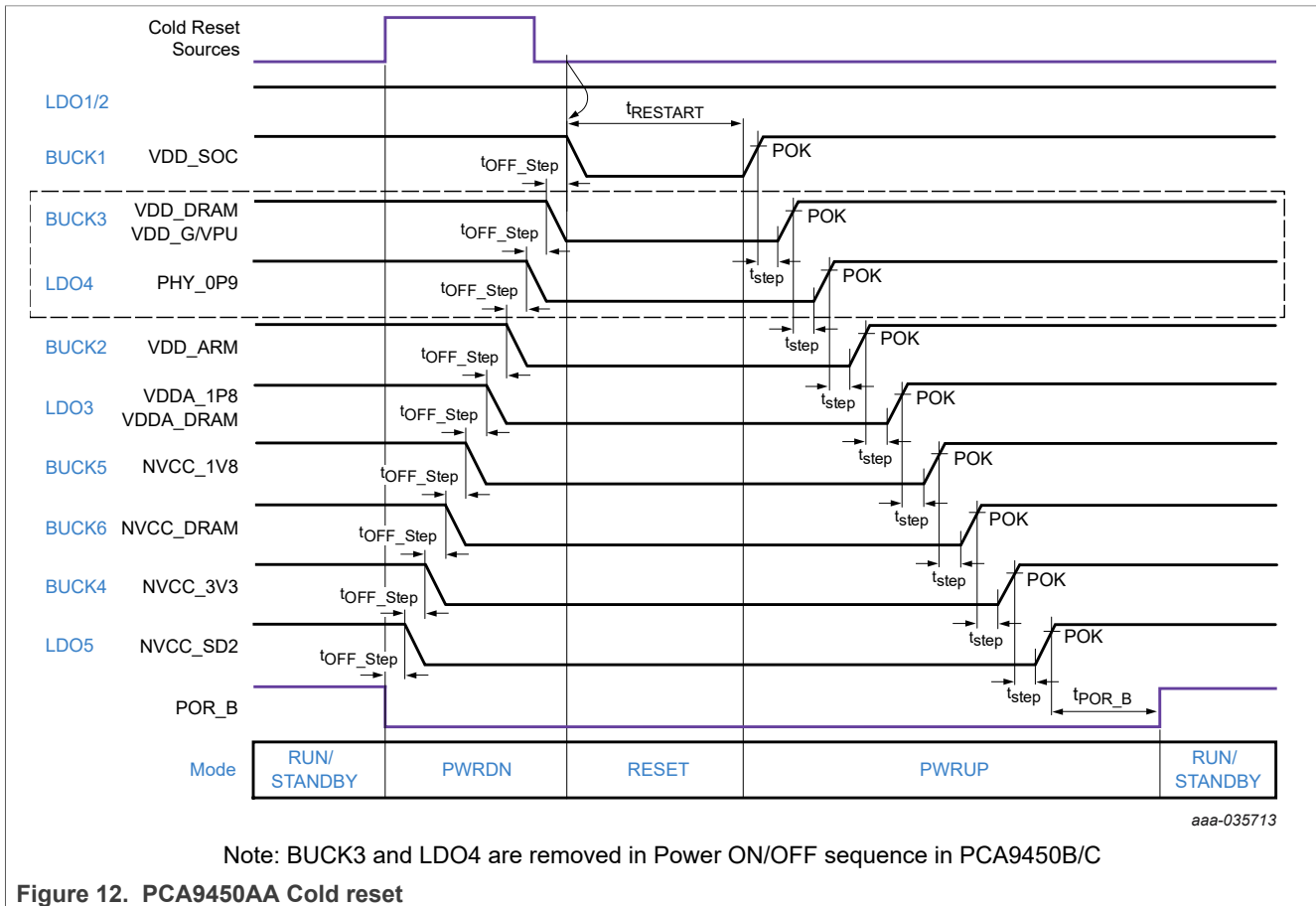

Note: BUCK3 and LDO4 are removed in Power ON/OFF sequence in PCA9450B/C

Figure 12. PCA9450AA Cold reset

Table 12. $t_{RESTART}$

Time	Description	Value
$t_{RESTART}$	Time to power ON seq from end of power OFF seq during cold reset	250 ms

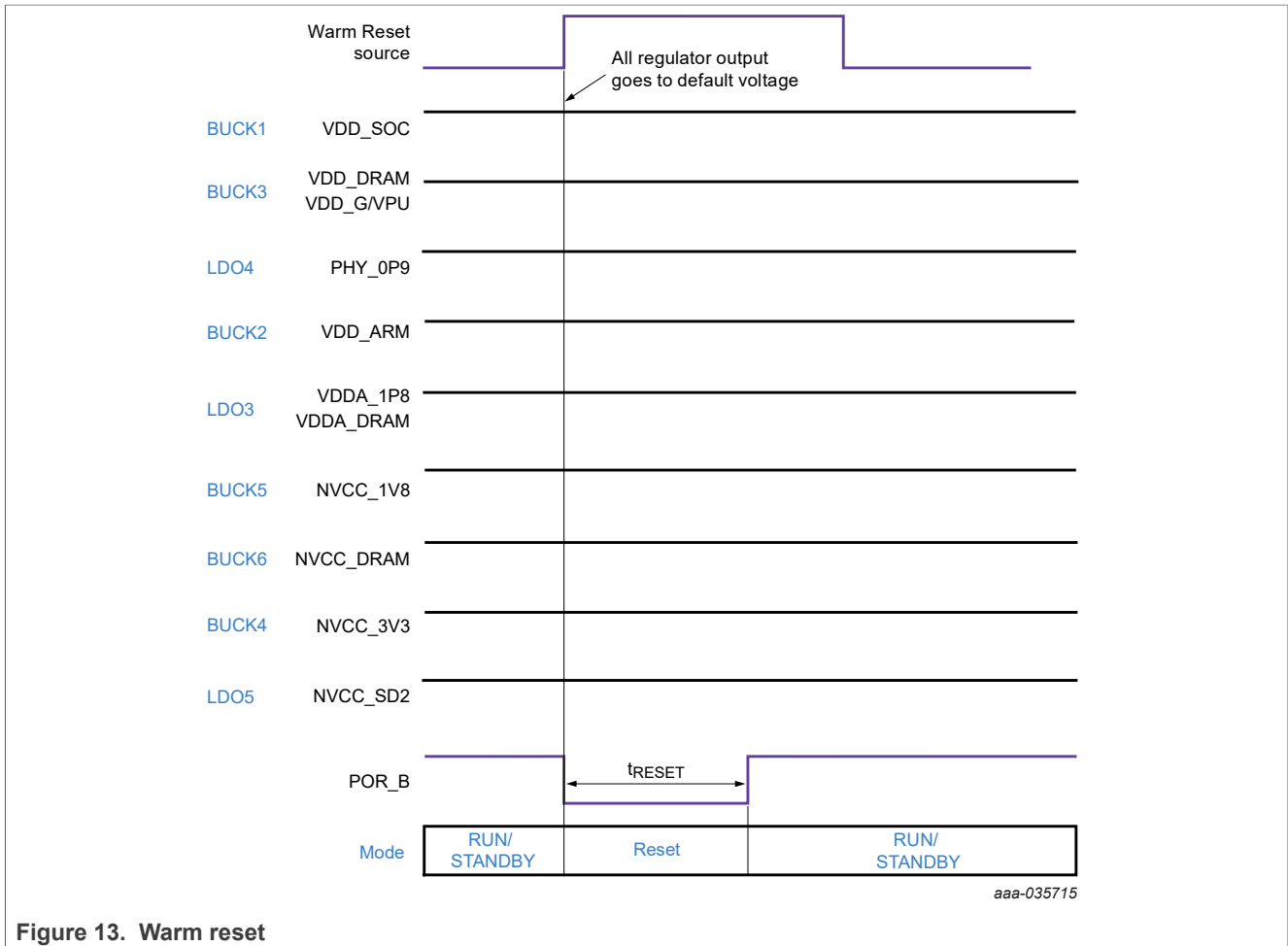

Figure 13. Warm reset

Table 13. t_{RESET}

Time	Description	Value
t _{RESET}	POR_B low time at Warm reset	20 ms

7.5 Regulator control in each power mode

Table 14 shows PCA9450AA regulator ON/OFF control in each power mode by default. It can be reconfigured through I2C registers.

Table 14. PCA9450AA Regulator Control summary

Power Rail		Default Voltage	OFF	SNVS	STANDBY	RUN
LDO1	NVCC_SNVS	1.8 V	OFF	ON	ON	ON
LDO2	VDD_SNVS	0.85 V	OFF	ON	ON	ON
BUCK1	VDD_SOC	0.85 V	OFF	OFF	ON	ON
BUCK3	VDD_DRAM VDD_GPU VDD_VPU	0.85 V	OFF	OFF	ON	ON
LDO4	PHY_0P9	0.9 V	OFF	OFF	ON	ON

Table 14. PCA9450AA Regulator Control summary...continued

Power Rail		Default Voltage	OFF	SNVS	STANDBY	RUN
BUCK2	VDD_ARM	0.85 V	OFF	OFF	OFF	ON
LDO3	VDDA_1P8	1.8 V	OFF	OFF	ON	ON
BUCK5	NVCC_1V8	1.8 V	OFF	OFF	ON	ON
BUCK6	NVCC_DRAM	1.1 V	OFF	OFF	ON	ON
BUCK4	NVCC_3V3	3.3 V	OFF	OFF	ON	ON
LDO5	NVCC_SD2	3.3 V / 1.8 V	OFF	OFF	ON	ON

[Table 15](#) shows PCA9450B/PCA9450C regulator ON/OFF control in each power mode by default. It can be reconfigured through I2C registers.

Table 15. PCA9450B/PCA9450C Regulator Control summary

Power Rail		Default Voltage	OFF	SNVS	STANDBY	RUN
LDO1	NVCC_SNVS	1.8 V	OFF	ON	ON	ON
LDO2	VDD_SNVS	0.85 V	OFF	ON	ON	ON
BUCK1	VDD_SOC VDD_DRAM VDD_GPU VDD_VPU	0.85 V	OFF	OFF	ON	ON
LDO4		0.9 V	OFF	OFF	OFF	OFF
BUCK2	VDD_ARM	0.85 V	OFF	OFF	OFF	ON
LDO3	VDDA_1P8	1.8 V	OFF	OFF	ON	ON
BUCK5	NVCC_1V8	1.8 V	OFF	OFF	ON	ON
BUCK6	NVCC_DRAM	1.1 V	OFF	OFF	ON	ON
BUCK4	NVCC_3V3	3.3 V	OFF	OFF	ON	ON
LDO5	NVCC_SD2	3.3 V / 1.8 V	OFF	OFF	ON	ON

7.6 Regulator summary

The PCA9450 features six buck regulators, five linear regulators and one load switch to supply voltage rails powering the application processor and peripheral devices. The buck regulators are supplied directly from the main input supply. The input to all of the buck regulators must be tied to VSYS, whether they are powered on or off.

7.6.1 BUCK regulator

The PCA9450AA has six high-efficiency low Iq buck regulators. Each buck regulator features soft start and overcurrent protection. Buck regulator operates in two modes: PFM and PWM mode. It automatically transitions from PFM to PWM mode when FPWM bit is set to "0". Internal active discharge resistor is installed in each buck regulator output to discharge voltage on output capacitors when regulator is off. It is configurable through I2C register. [Table 16](#) shows buck regulator summary.

BUCK1 and BUCK3 are configured as dual-phase buck regulator in PCA9450C and provide up to 6 A. [Table 17](#) shows PCA9450C buck summary.

Table 16. PCA9450AA Buck Summary

BUCK#	INPUT PIN	Default VOUT [V]	VOUT range [V]	Step size [mV]	Default ON/OFF	Current rating [mA]
BUCK1	INB13	0.85	0.6 - 2.1875	12.5	ON	3000
BUCK2	INB26	0.85	0.6 - 2.1875	12.5	ON	3000
BUCK3	INB13	0.85	0.6 - 2.1875	12.5	ON	3000
BUCK4	INB45	3.3	0.6 - 3.4	25	ON	3000
BUCK5	INB45	1.8	0.6 - 3.4	25	ON	2000
BUCK6	INB26	1.1	0.6 - 3.4	25	ON	2000

Table 17. PCA9450C Buck Summary

Buck#	INPUT PIN	Default VOUT [V]	VOUT range [V]	Step size [mV]	Default ON/OFF	Current rating [mA]
BUCK1	INB13	0.85	0.6 - 2.1875	12.5	ON	6000
BUCK2	INB26	0.85	0.6 - 2.1875	12.5	ON	3000
BUCK4	INB45	3.3	0.6 - 3.4	25	ON	3000
BUCK5	INB45	1.8	0.6 - 3.4	25	ON	2000
BUCK6	INB26	1.1	0.6 - 3.4	25	ON	2000

7.6.1.1 Dynamic voltage scaling

BUCK1, BUCK2 and BUCK3 support DVS (Dynamic Voltage Scaling). If PRESET_EN bit in BUCK123_DVS register is set to 1, BUCK1/BUCK2/BUCK3 outputs are controlled by Bx_DVS_PRESET bits in BUCK123_DVS. It enables those buck outputs to be controlled by writing one register at a time.

If PRESET_EN bit is set to 0, those buck regulators outputs are determined by BUCKxOUT_DVS0 and BUCKxOUT_DVS1 depending on PMIC_STBY_REQ pin. When PMIC_STBY_REQ is asserted low, each buck output voltage is determined by BUCKxOUT_DVS0 register, if the PMIC_STBY_REQ is asserted high, BUCKxOUT_DVS1 register is selected as each buck output voltage. [Figure 14](#) shows the DVS voltage section diagram.

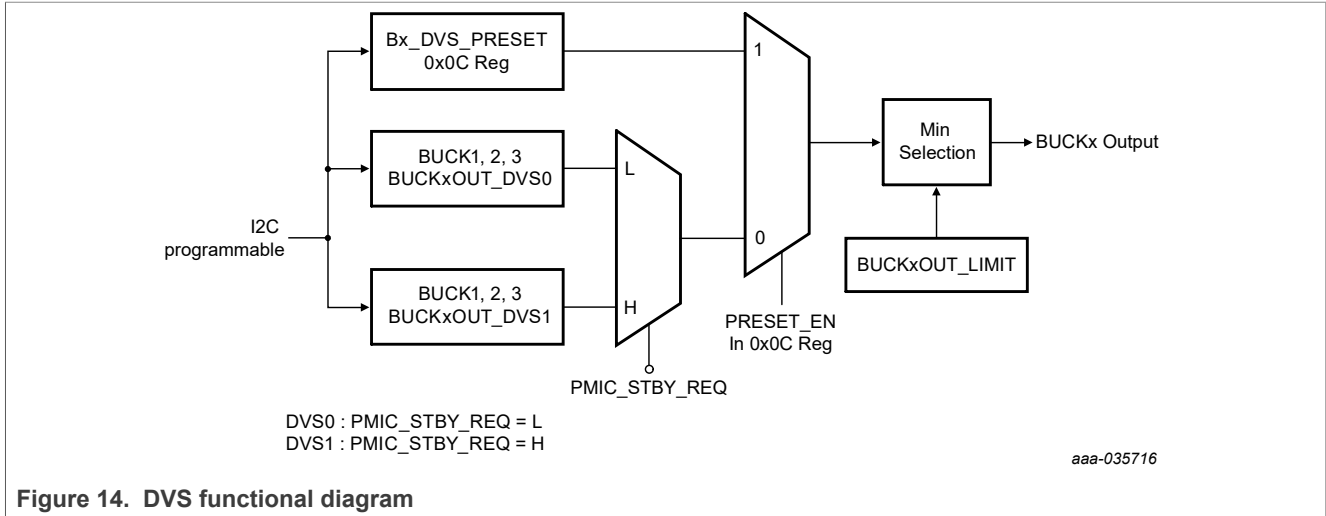

Figure 14. DVS functional diagram

The programmable voltage ramp-up and ramp-down are applied during the DVS voltage transition. The ramp rate is configured by RAMP[7:6] bits in each BUCKxCTRL registers.

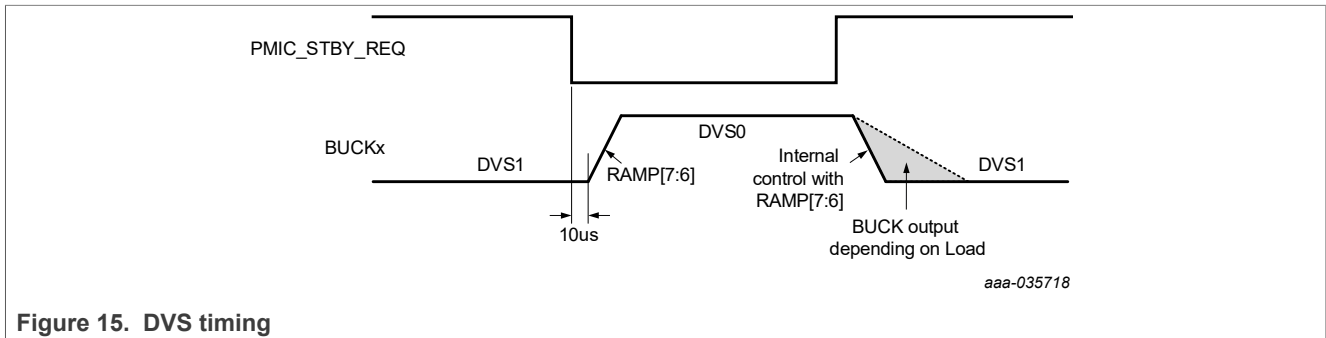

Figure 15. DVS timing

7.6.1.2 BUCK output voltage limiting

Application processor may accidentally write higher voltage than absolute maximum voltage rating of its power input, which may cause significant damage on application processor. PCA9450 has registers to limit the maximum voltage to prevent such an incident.

BUCK1, BUCK2 and BUCK3 maximum output are limited by BUCKxOUT_LIMIT, respectively. Even if buck output is configured to higher than the limit voltage configured in BUCKxOUT_LIMIT register, the actual buck output is clamped to the limiting voltage set by BUCKxOUT_LIMIT register.

7.6.1.3 Dual-phase configuration

BUCK1 and BUCK3 are configured as dual phase buck in PCA9450C by connecting R_SNSP3_CFG pin to GND, where this dual phase buck regulator is controlled through BUCK1 registers. All BUCK3 registers are not responsive under dual-phase configuration.

When R_SNSP3_CFG pin is tied to INB13 in PCA9450B, BUCK3 is disabled. BUCK1 supplies VDD_SOC/VDD_VPU/VDD_GPU/VDD_DRAM in i.MX 8M Nano application processor.

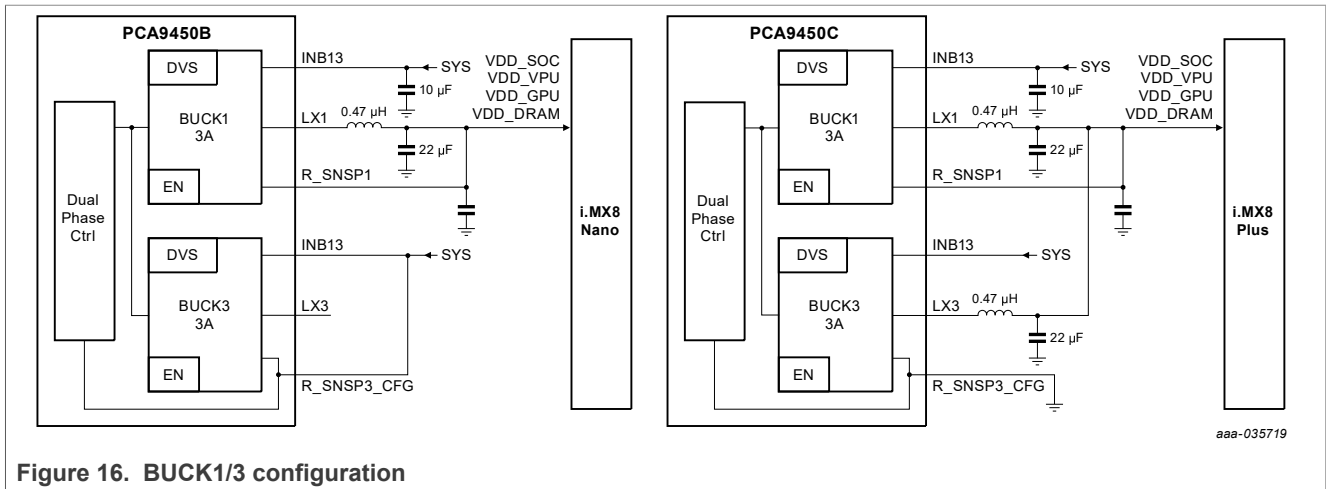

7.6.2 LDO and load switch

The PCA9450 has five LDOs and one load switch. LDO1 and LDO2 are supposed to supply SNVS core in application processor. These two LDOs feature ultra-low quiescent current, 2 μA typical, since they are always ON when V_{SY}S is valid.

For all LDO and the load switch, each has designated active discharge resistor configurable through I2C.

Table 18. LDO summary

LDO#	INPUT PIN	Default VOUT [V]	VOUT range [V]	Step size [mV]	Default ON/OFF	Current rating [mA]
LDO1	INL1	1.8	1.6-1.9, 3.0-3.3	100	ON	10
LDO2	INL1	0.85	0.8 – 1.15	50	ON	10
LDO3	INL1	1.8	0.8 - 3.3	100	ON	300
LDO4	INL1	0.9	0.8 - 3.3	100	ON ^[1]	200
LDO5	INL1	3.3/1.8	1.8 - 3.3	100	ON	150
SW	SWIN	-	-	-	OFF	400

[1] ON by default in PCA9450AA, OFF by default in PCA9450B and PCA9450C

7.7 32 kHz Crystal Oscillator Driver

The PCA9450 consists of a crystal oscillator driver with an external load capacitor and CLK_32K_OUT buffer referenced to LDO1 voltage. When V_{SY}S exceeds POR threshold and internal power V_{INT} is good, internal 32 kHz oscillator and 32.768 kHz crystal oscillator start oscillating. Crystal oscillator typically takes few seconds to be stabilized. PCA9450 outputs the internal 32 kHz RC oscillator initially, while internal counter counts crystal oscillator output in t_{RTC_Tran} after RTC_RESET_B is released. If the counter reaches 100, then CLK_32K_OUT buffer input is switched to the external crystal oscillator from internal 32 kHz oscillator. Clock stretch is applied during this clock source transition to prevent unwanted glitch. If external 32.768 kHz crystal oscillator is not populated, CLK_32K_OUT pin outputs 32 kHz clock from internal 32 kHz oscillator.

For more detailed information on selecting crystal oscillator and load capacitance, refer to [Section 9.2.2](#).

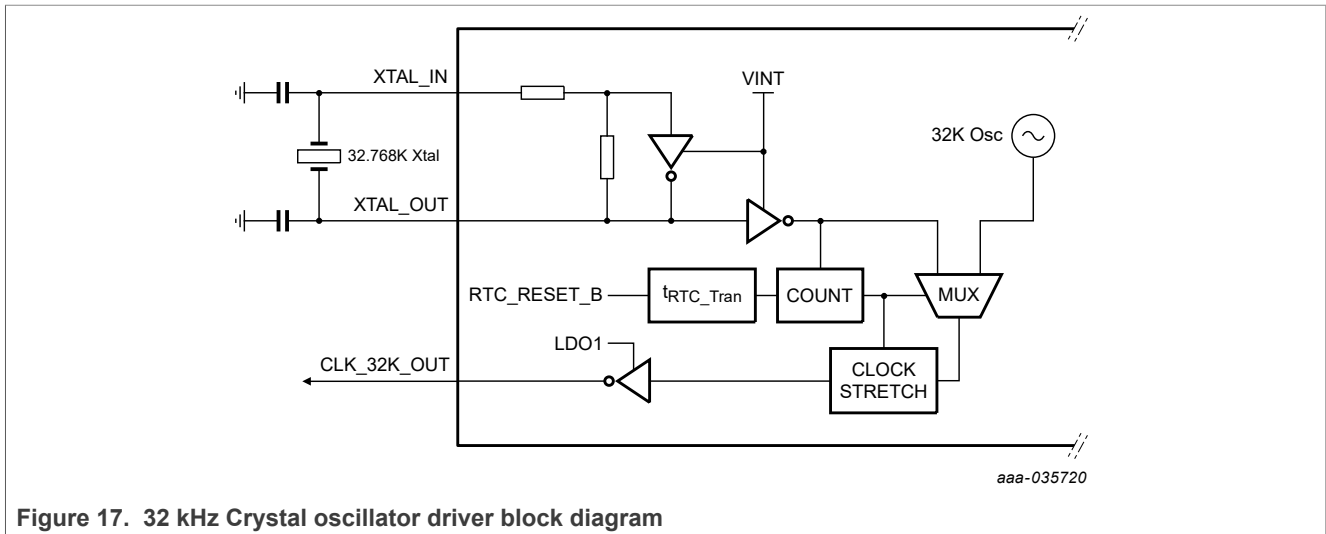

Figure 17. 32 kHz Crystal oscillator driver block diagram

7.8 Load switch

PCA9450 integrates 400 mA load switch which is used to supply SD card VDD. SWIN is connected to BUCK4 output, 3.3 V, in this application. It is enabled by SW_EN pin or SW_EN[1:0] bits in LOADSW_CTRL register. It has soft start feature to reduce inrush current during turn-on. This load switch has overcurrent protection and short circuit protection by monitoring voltage difference between SWIN and SWOUT. When the switch current exceeds overcurrent threshold (I_{OC}) for overcurrent debounce time (t_{OC_DEB}), SW_OCP bit in VRFLT1_STS register is set to 1 and the fault behavior is determined by SW_OC[1:0] configuration in LOADSW_CTRL register. When the switch current exceeds short-circuit current threshold (I_{SC}), SW_OCP bit in VRFLT1_STS register is set to 1 and switch is turned off right away.

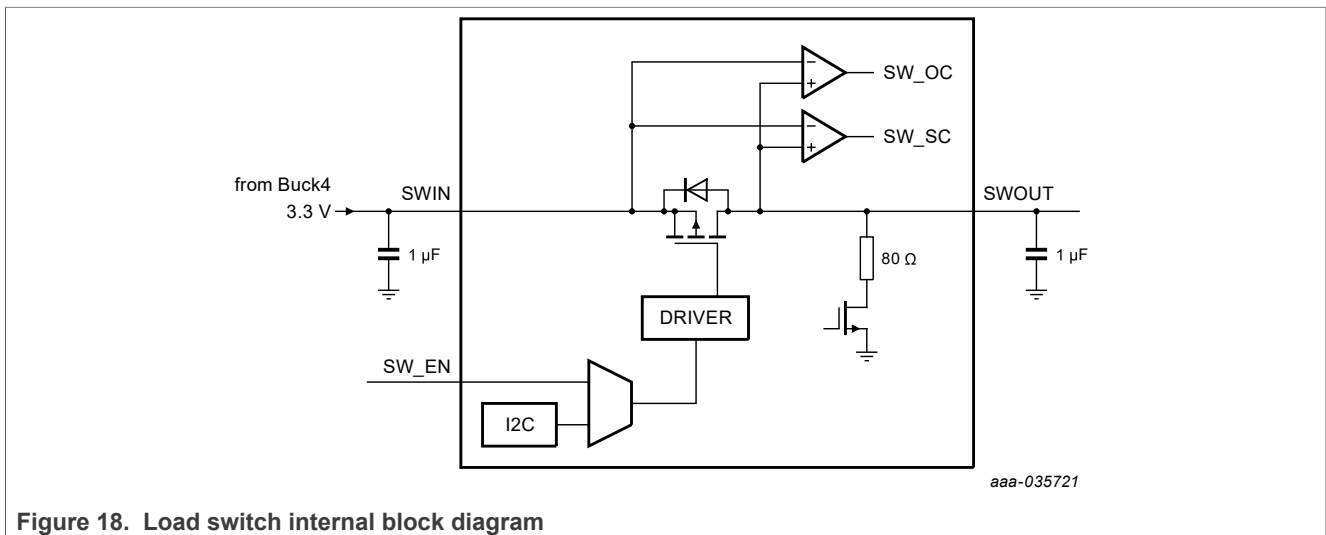

Figure 18. Load switch internal block diagram

7.9 I²C level translator

PCA9450 I²C level translator is a "switch" type voltage translator, and employs two key circuits to enable voltage translation:

1. A pass-gate transistor (N-channel) that ties the ports together.
2. An output edge-rate accelerator that detects and accelerates rising edges on the I/O pins.

The gate bias voltage of the pass gate transistor (T3) is set at approximately one threshold voltage above the VCC level of the low-voltage side. During a LOW-to-HIGH transition the output one-shot accelerates the output transition by switching on the PMOS transistors (T1, T2) bypassing the 10 kΩ pull-up resistors and increasing current drive capability. The one-shot is activated once the input transition reaches approximately VCC/2; it is de-activated approximately 50 ns after the output reaches VCCO/2. During the acceleration time the driver output resistance is between approximately 50 Ω and 70 Ω. To avoid signal contention and minimize dynamic ICC, the user should wait for the one-shot circuit to turn off before applying a signal in the opposite direction. Pull-up resistors are included in the device for DC current sourcing capability.

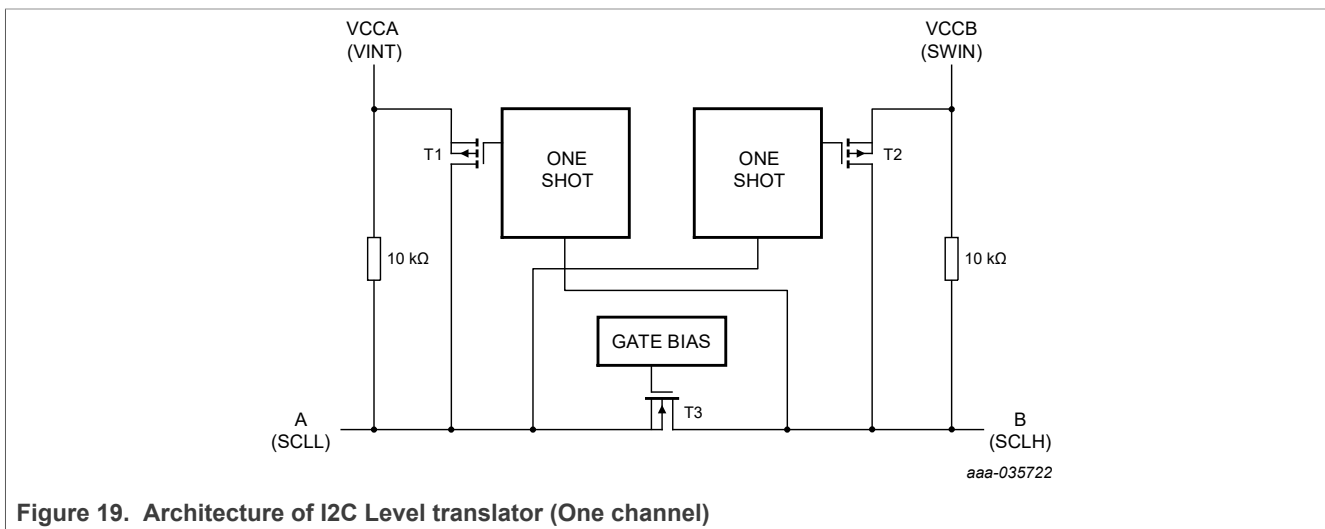

Figure 19. Architecture of I2C Level translator (One channel)

Each A port I/O has an internal 10 kΩ pull-up resistor to VCCA, and each B port I/O has an internal 10 kΩ pull-up resistor to VCCB. If a smaller value of pull-up resistor is required, an external resistor must be added parallel to the internal 10 kΩ, affecting the VOL level. When Level translator is disabled through I2C, the internal pull up resistors are disconnected.

PCA9450 I2C Level translator is controlled by I2C register, CONFIG2 Reg. When it is configured to disabled, all I/Os assume the high-impedance OFF-state. The enable time (ten) indicates the amount of time the user must allow for one one-shot circuitry to become operational after it is enabled.

7.10 Interrupt management

The IRQ_B pin is an interface to the software-controlled system that indicates any interrupt bit status change of INT1 register. The IRQ_B pin is pulled low when any unmasked interrupt bit status is changed and it is released high once application processor reads INT1 register.

The INT1 bits are latched to 1 whenever corresponding STATUS1 bits are changed and the latch is cleared when the INT1 register is read. The INT1_MASK bits are used to enable or disable individual interrupt bits of INT1 register. The STATUS1 register indicates the current status and is not latched.

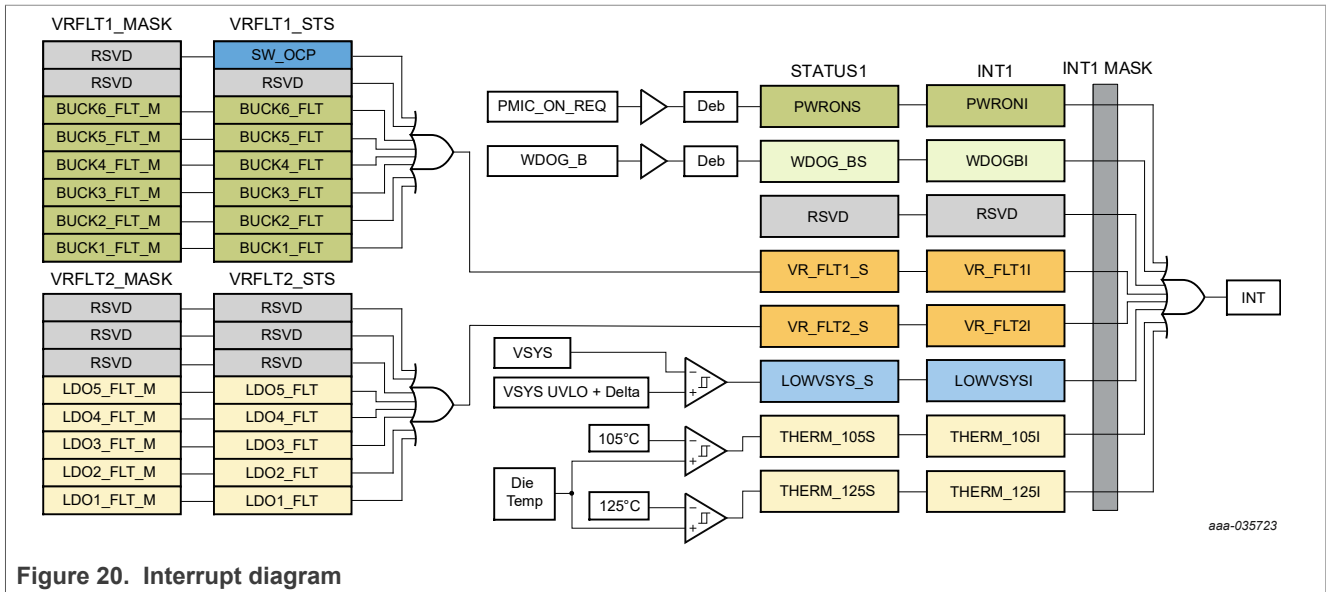

Figure 20. Interrupt diagram

8 Software interface

PCA9450 implements I2C-bus slave interface and it interfaces with the host system. The host processor can issue commands, monitor status and receive response through this bus. A detailed description of the I2C-bus specification, with applications, is given in UM10204, “[I2C-bus specification and user manual](#)” [Ref. 4]. PCA9450 supports I2C-bus data transfers in Standard-mode (100 kbit/s), Fast-mode (400 kbit/s) and Fast-mode plus (1 Mbit/s).

The I2C address at Power-On Reset is shown in [Table 19](#)

Table 19. PCA9450 I2C Slave Address

7-bit Slave Address	8-bit Write Address	8-bit Read Address
0x25, 0b 010 0101	0x4A, 0b 0100 1010	0x4B, 0b 0100 1011

I2C register reset type

Type S1 : Reset condition = $VSYS < V_{SYS_POR}$

Type S : Reset condition = $VSYS < V_{SYS_UVLO}$

Type O : Reset condition = $(VSYS < V_{SYS_UVLO}) \parallel$ (Cold Reset) \parallel (Warm Reset) \parallel (Falling edge of PMIC_ON_REQ) \parallel (SW_RST) \parallel (FAULT_SD)

8.1 Register map

Table 20. Register map

Add	Name	Description								R/W	Reset Type	Reset Value
		B7	B6	B5	B4	B3	B2	B1	B0			
0x00	Device_ID	CHIP_ID				RSVD				R	S	0x11
0x01	INT1	PWERONI	WDOGBI	RSVD	VR_FLT1I	VR_FLT2I	LOWVSYSI	THERM_105I	THERM_125I	R/C	S	0x00
0x02	INT1_MSK	PWRONI_M	WDOGB_M	RSVD	VR_FLT1_M	VR_FLT2_M	LOWVSYSM	THERM_105_M	THERM_125_M	R/W	S	0xFF
0x03	STATUS1	PWRONS	WDOGBS	RSVD	VR_FLT1S	VR_FLT2S	LOWVSYSS	THERM_105S	THERM_125S	R	S	0x00
0x04	STATUS2	RSVD	RSVD	RSVD	RSVD	POWER_STATUS				R	S1	0x00
0x05	PWRON_STAT	PWRON	WDOG	SW_RST	PMIC_RST	RSVD	RSVD	RSVD	RSVD	R/C	S	0x00
0x06	SW_RST	SW_RST								R/W	O	0x00
0x07	PWR_CTRL	Ton_Deb		Toff_Deb	Tstep		Toff_step		Trestart	R/W	S	0x4C
0x08	RESET_CTRL	WDOGB_CFG		PMIC_RST_CFG		RSVD	T_PMIC_RST_DEB			R/W	S	0x21
0x09	CONFIG1	LOW_VSYS		VSYS_UVLO		RSVD	RSVD	tFLT_SD_WAIT	THERM_SD_DIS	R/W	S1	0x50
0x0A	CONFIG2	RSVD	RSVD	RSVD	RSVD	RSVD	RSVD	I2C_LT_EN		R/W	O	0x00
0x0C	BUCK123_DVS	PRESET_EN	B3_DVS_PRESET		B1_DVS_PRESET		B2_DVS_PRESET			R/W	O	0xA9
0x0D	BUCK1OUT_LIMIT	RSVD	B1_LIMIT							R/W	O	0x1C
0x0E	BUCK2OUT_LIMIT	RSVD	B2_LIMIT							R/W	O	0x20
0x0F	BUCK3OUT_LIMIT	RSVD	B3_LIMIT							R/W	O	0x1C
0x10	BUCK1CTRL	RAMP		RSVD	DVS_CTRL	BUCK1AD	FPWM	B1_ENMODE		R/W	O	0x49
0x11	BUCK1OUT_DVS0	RSVD	B1_DVS0							R/W	O	0x14
0x12	BUCK1OUT_DVS1	RSVD	B1_DVS1							R/W	O	0x14
0x13	BUCK2CTRL	RAMP		RSVD	DVS_CTRL	BUCK2AD	FPWM	B2_ENMODE		R/W	O	0x4A
0x14	BUCK2OUT_DVS0	RSVD	B2_DVS0							R/W	O	0x14

Table 20. Register map...continued

Add	Name	Description								R/W	Reset Type	Reset Value	
		B7	B6	B5	B4	B3	B2	B1	B0				
0x15	BUCK2OUT_DVS1	RSVD	B2_DVS1								R/W	O	0x14
0x16	BUCK3CTRL	RAMP		RSVD	DVS_CTRL	BUCK3AD	FPWM	B3_ENMODE		R/W	O	0x49	
0x17	BUCK3OUT_DVS0	RSVD	B3_DVS0								R/W	O	0x14
0x18	BUCK3OUT_DVS1	RSVD	B3_DVS1								R/W	O	0x14
0x19	BUCK4CTRL	RSVD	RSVD	RSVD	RSVD	BUCK4AD	FPWM	B4_ENMODE		R/W	O	0x09	
0x1A	BUCK4OUT	RSVD	B4_OUT								R/W	O	0x6C
0x1B	BUCK5CTRL	RSVD	RSVD	RSVD	RSVD	BUCK5AD	FPWM	B5_ENMODE		R/W	O	0x09	
0x1C	BUCK5OUT	RSVD	B5_OUT								R/W	O	0x30
0x1D	BUCK6CTRL	RSVD	RSVD	RSVD	RSVD	BUCK6AD	FPWM	B6_ENMODE		R/W	O	0x09	
0x1E	BUCK6OUT	RSVD	B6_OUT								R/W	O	0x14
0x20	LDO_AD_CTRL	LDO1_AD	LDO2_AD	LDO3_AD	LDO4_AD	LDO5_AD	RSVD	RSVD	RSVD	R/W	O	0xF8	
0x21	LDO1CTRL	ENMODE		RSVD	RSVD	RSVD	L1_OUT			R/W	O	0xC2	
0x22	LDO2CTRL	ENMODE		RSVD	RSVD	RSVD	L2_OUT			R/W	O	0xC1	
0x23	LDO3CTRL	ENMODE		RSVD	L3_OUT					R/W	O	0x4A	
0x24	LDO4CTRL	ENMODE		RSVD	L4_OUT					R/W	O	0x41	
0x25	LDO5CTRL_L	ENMODE		RSVD	RSVD	L5_OUT_L				R/W	O	0x4F	
0x26	LDO5CTRL_H	RSVD	RSVD	RSVD	RSVD	L5_OUT_H				R/W	O	0x00	
0x27	RSVD	RSVD								R/W	O	0x00	
0x28	RSVD	RSVD								R/W	O	0x00	
0x29	RSVD	RSVD								R/W	O	0x00	
0x2A	LOADSW_CTRL	SW_AD	RSVD	RSVD	SW_SC	SW_OC		SWEN		R/W	O	0x85	
0x2B	VRFLT1_STS	SW_OCP	RSVD	BUCK6_FLT	BUCK5_FLT	BUCK4_FLT	BUCK3_FLT	BUCK2_FLT	BUCK1_FLT	R/W/C	S	0x00	
0x2C	VRFLT2_STS	RSVD	RSVD	RSVD	LDO5_FLT	LDO4_FLT	LDO3_FLT	LDO2_FLT	LDO1_FLT	R/W/C	S	0x00	

Table 20. Register map...continued

Add	Name	Description								R/W	Reset Type	Reset Value
		B7	B6	B5	B4	B3	B2	B1	B0			
0x2D	VRFLT1_MASK	RSVD	RSVD	BUCK6_FLT_M	BUCK5_FLT_M	BUCK4_FLT_M	BUCK3_FLT_M	BUCK2_FLT_M	BUCK1_FLT_M	R/W	S	0x3F
0x2E	VRFLT2_MASK	RSVD	RSVD	RSVD	LDO5_FLT_M	LDO4_FLT_M	LDO3_FLT_M	LDO2_FLT_M	LDO1_FLT_M	R/W	S	0x1F

8.2 Register details

8.2.1 0x00 Device_ID

The device identification code stores a unique identifier for each version and/or revision of a PCA9450, so that the connected processor recognizes it automatically.

Table 21. 0x00 Device_ID

0x00 – Device_ID				Reset Type	S
Bit	Name	Type	Reset	Description	
7:4	CHIP_ID	R	0001	Chip ID 0001b = PCA9450AA 0011b = PCA9450B, PCA9450C	
3:0	RSVD	R	0001	Reserved	

8.2.2 0x01 INT1

Interrupt source register. Either of unmasked register bits is set to 1, IRQ_B pin is pulled low. This register is Read and Clear.

Table 22. 0x01 INT1

0x01 – INT1				Reset Type	S
Bit	Name	Type	Reset	Description	
7	PWRONI	R/C	0	PWRON interrupt bit 0b = PWRONS bit has not been changed 1b = PWRONS bit has been changed	
6	WDOGBI	R/C	0	WDOGB interrupt bit 0b = WDOG_BS bit has not been changed 1b = WDOG_BS bit has been changed	
5	RSVD	R/C	0	Reserved	
4	VR_FLT1I	R/C	0	Voltage regulator Group1 Fault interrupt 0b = VR_FLT1S bit has not been changed 1b = VR_FLT1S bit has been changed	
3	VR_FLT2I	R/C	0	Voltage regulator Group2 Fault interrupt 0b = VR_FLT2S bit has not been changed 1b = VR_FLT2S bit has been changed	
2	LOWVSYSI	R/C	0	Low-SYS Voltage interrupt bit 0b = LOWVSYSS bit has not been changed 1b = LOWVSYSS bit has been changed	
1	THERM_105I	R/C	0	Die temperature 105 °C interrupt 0b = THERM_105S bit has not been changed 1b = THERM_105S bit has been changed	
0	THERM_125I	R/C	0	Die temperature 125 °C interrupt 0b = THERM_125S bit has not been changed 1b = THERM_125S bit has been changed	

8.2.3 0x02 INT1_MSK

The INT1_MSK register enables the masking (disabling) of the different interrupt signals of register INT1. When unmasked, interrupt events trigger the IRQB pin to be pulled low when the matching flag bit in the register INT1 is set.

Table 23. 0x02 INT1_MSK

0x02 – INT1_MSK				Reset Type	S
Bit	Name	Type	Reset	Description	
7	PWRON_M	R/W	1	PWRON interrupt mask bit 0b = Enable PWRON interrupt 1b = Mask PWRON interrupt	
6	WDOGB_M	R/W	1	WDOGBI interrupt mask bit 0b = Enable WDOGBI interrupt 1b = Mask WDOGBI interrupt	
5	RSVD	R/W	1	Reserved	
4	VR_FLT1_M	R/W	1	VR_FLT1I interrupt mask bit 0b = Enable VR_FLT1I interrupt 1b = Mask VR_FLT1I interrupt	
3	VR_FLT2_M	R/W	1	VR_FLT2I interrupt mask bit 0b = Enable VR_FLT2I interrupt 1b = Mask VR_FLT2I interrupt	
2	LOWVSYS_M	R/W	1	LOWVINI interrupt mask bit 0b = Enable LOWVINI interrupt 1b = Mask LOWVINI interrupt	
1	THERM_105_M	R/W	1	THERM_105 interrupt mask bit 0b = Enable THERM_105 interrupt 1b = Mask THERM_105 interrupt	
0	THERM_125_M	R/W	1	THERM_125 interrupt mask bit 0b = Enable THERM_125 interrupt 1b = Mask THERM_125 interrupt	

8.2.4 0x03 STATUS1

STATUS1 register show current status. Any status bit change set corresponding interrupt bit to 1.

Table 24. 0x03 STATUS1

0x03 – STATUS1				Reset Type	S
Bit	Name	Type	Reset	Description	
7	PWRONS	R	0	PMIC_ON_REQ pin status after debounce time 0b = PMIC_ON_REQ pin is low 1b = PMIC_ON_REQ pin is high	
6	WDOG_BS	R	0	WDOG_B pin status 0b = WDOG_B pin is low 1b = WDOG_B pin is high	
5	RSVD	R	0	Reserved	

Table 24. 0x03 STATUS1...continued

0x03 – STATUS1				Reset Type	S
Bit	Name	Type	Reset	Description	
4	VR_FLT1S	R	0	Voltage Regulator Fault status, See 0x2B Register. 0b = All voltage regulators are OK 1b = Either of voltage regulators is in Fault state	
3	VR_FLT2S	R	0	Voltage Regulator POK status, See 0x2C Registers. 0b = All voltage regulators are OK 1b = Either of voltage regulators is in Fault state	
2	LOWVSYS	R	0	VSYS low voltage status 0b = VSYS > Low VSYS threshold 1b = VSYS ≤ Low VSYS threshold	
1	THERM_105S	R	0	Die temperature 105 °C status 0b = Die temperature is below 105 °C 1b = Die temperature is above 105 °C	
0	THERM_125S	R	0	Die temperature 125 °C status 0b = Die temperature is below 125 °C 1b = Die temperature is above 125 °C	

8.2.5 0x04 STATUS2

STATUS2 register shows current PCA9450 power status.

Table 25. 0x04 STATUS2

0x04 – STATUS2				Reset Type	S1
Bit	Name	Type	Reset	Description	
7:4	RSVD	R	0000	Reserved	
3:0	POWER_STATUS	R	0000	Current PCA9450 power status 0000b = OFF 0001b = READY 0010b = SNVS 0011b = PWRUP 0100b = RUN 0101b = STANDBY 0110b = PWRDN 0111b = WARM RESET 1000b = COLD RESET 1001b = FAULT Shutdown 1010b – 1111b = Reserved	

8.2.6 0x05 PWRON_STAT

Power ON source register. It is latched to 1 until the bit is read back.

Table 26. 0x05 PWRON_STAT

0x05 – PWRON_STAT				Reset Type	S
Bit	Name	Type	Reset	Description	
7	PWRON	R/C	0	1b = Power ON triggered by PMIC_ON_REQ. This bit will be set right after completing power up sequence.	
6	WDOG	R/C	0	1b = This bit is set after cold reset by WDOGB pin	
5	SW_RST	R/C	0	1b = This bit is set after cold reset by SW_RST bit	
4	PMIC_RST	R/C	0	1b = This bit is set after cold reset by PMIC_RST_B	
3	RSVD	R/C	0	Reserved	
2	RSVD	R/C	0	Reserved	
1	RSVD	R/C	0	Reserved	
0	RSVD	R/C	0	Reserved	

8.2.7 0x06 SW_RST

Software reset register through I2C.

Table 27. 0x06 SW_RST

0x06 – SW_RST				Reset Type	O
Bit	Name	Type	Reset	Description	
7:0	SW_RST	R/W	0x00	Software reset register. This register is read back to "0x00" right after writing the value. 0x00 = No action 0x05 = Reset all registers to default value 0x14 = Cold reset (Power recycle all regulators except LDO1, LDO2 and CLK_32K_OUT) 0x35 = Warm Reset (Toggle POR_B for 20 ms) 0x64 = Cold reset (Power recycle all regulators) Others = No action	

8.2.8 0x07 PWR_CTRL

Debounce timer configuration register

Table 28. 0x07 PWR_CTRL

0x07 – PWR_CTRL				Reset Type	S
Bit	Name	Type	Reset	Description	
7:6	Ton_Deb	R/W	01	Debounce time for PMIC_ON_REQ high. 00b = 120 μ s 01b = 20 ms 10b = 100 ms 11b = 750 ms	
5	Toff_Deb	R/W	0	Debounce time for PMIC_ON_REQ is asserted low 0b = 120 μs 1b = 2 ms	

Table 28. 0x07 PWR_CTRL...continued

0x07 – PWR_CTRL				Reset Type	S
Bit	Name	Type	Reset	Description	
4:3	Tstep	R/W	01	Time step configuration during power on sequence 00b = 1 ms 01b = 2 ms 10b = 4 ms 11b = 8 ms	
2:1	Toff_step	R/W	10	Time step configuration during power down sequence 00b = 2 ms 01b = 4 ms 10b = 8 ms 11b = 16 ms	
0	Trestart	R/W	0	Time to stay regulators off during Cold reset 0b = 250 ms 1b = 500 ms	

8.2.9 0x08 RESET_CTRL

Reset behavior configuration register through WDOG_B and PMIC_RST_B pin.

Table 29. 0x08 RESET_CTRL

0x08 – RESET_CTRL				Reset Type	S
Bit	Name	Type	Reset	Description	
7:6	WDOG_B_CFG	R/W	00	When WDOG_B is asserted to low, PMIC reset behavior 00b = WDOG_B reset is disabled 01b = Warm Reset, POR_B pin is asserted low for 20 ms 10b = Cold Reset, All voltage regulators are recycled except LDO1/ LDO2 11b = Cold Reset, All voltage regulators are recycled	
5:4	PMIC_RST_CFG	R/W	10	When PMIC_RST_B is asserted to low, PMIC reset behavior 00b = PMIC_RST_B reset is disabled 01b = Warm Reset, POR_B pin is asserted low for 20 ms 10b = Cold Reset, All voltage regulators are recycled except LDO1/LDO2 11b = Cold Reset, All voltage regulators are recycled	
3	RSVD	R/W	0	Reserved	
2:0	T_PMIC_RST_DEB	R/W	001	PMIC_RST_B debounce time 000b = 10 ms 001b = 50 ms 010b = 100 ms 011b = 500 ms 100b = 1 sec 101b = 2 sec 110b = 4 sec 111b = 8 sec	

8.2.10 0x09 CONFIG1

VSYS_UVLO and LOW VSYS configuration register

Table 30. 0x09 CONFIG1

0x09 – CONFIG1				Reset Type	S1
Bit	Name	Type	Reset	Description	
7:6	LOW_VSYS	R/W	01	Low VSYS threshold above V_{SYS_UVLO} 00b = 100 mV 01b = 200 mV 10b = 300 mV 11b = 400 mV	
5:4	VSYS_UVLO	R/W	01	VSYS UVLO Rising threshold 00b = 2.85 V 01b = 3.0 V 10b = 3.15 V 11b = 3.3 V	
3:2	RSVD	R/W	00	Reserved	
1	tFLT_SD_WAIT	R/W	0	Wait time for AP action when regulator fault occurs 0b = 100 ms 1b = 120 μ s	
0	THERM_SD_DIS	R/W	0	Thermal shutdown disable bit 0b = Enable Thermal shutdown 1b = Disable Thermal shutdown	

8.2.11 0x0A CONFIG2

I2C Level translator control register

Table 31. 0x0A CONFIG2

0x0A – CONFIG2				Reset Type	O
Bit	Name	Type	Reset	Description	
7	RSVD	R/W	0	Reserved	
6:4	RSVD	R/W	000	Reserved	
3:2	RSVD	R/W	00	Reserved	
1:0	I2C_LT_EN	R/W	00	I2C level translator enable 00b = Forced Disable 01b = Enable only when STANDBY and RUN mode 10b = Enable only when RUN mode 11b = Forced enable	

8.2.12 0x0C BUCK123_DVS

BUCK1, BUCK2, BUCK3 DVS control register with preset value

Table 32. 0x0C BUCK123_DVS

0x0C – BUCK123_DVS				Reset Type	O
Bit	Name	Type	Reset	Description	
7	PRESET_EN	R/W	1	BUCK123 output voltage selection 0b = BUCK voltage is determined by each BUCKxOUT_DVS0 or BUCKxOUT_DVS1. 1b = BUCK voltage is determined by Bx_DVS_PRESET bits.	
6:5	B3_DVS_PRESET	R/W	01	BUCK3 (VPU/GPU) Preset voltage option, only for PCA9450AA. 00b = 0.8 V 01b = 0.85 V 10b = 0.9 V 11b = 0.95 V	
4:3	B1_DVS_PRESET	R/W	01	BUCK1 (SOC) Preset voltage option 00b = 0.8 V 01b = 0.85 V 10b = 0.9 V 11b = 0.95 V	
2:0	B2_DVS_PRESET	R/W	001	BUCK2 (ARM) Preset voltage option 000b = 0.8 V 001b = 0.85 V 010b = 0.9 V 011b = 0.95 V 100b – 111b = 1.0 V	

8.2.13 0x0D BUCK1OUT_LIMIT

BUCK1 output voltage limit register

Table 33. 0x0D BUCK1OUT_LIMIT

0x0D – BUCK1OUT_LIMIT				Reset Type	O
Bit	Name	Type	Reset	Description	
7	RSVD	R/W	0	Reserved	
6:0	B1_LIMIT	R/W	001 1100	BUCK1 output voltage limit Programmable from 0.60 V to 2.1875 V in 12.5 mV step Default = 0.95 V	

8.2.14 0x0E BUCK2OUT_LIMIT

BUCK2 output voltage limit register

Table 34. 0x0E BUCK2OUT_LIMIT

0x0E – BUCK2OUT_LIMIT				Reset Type	O
Bit	Name	Type	Reset	Description	
7	RSVD	R/W	0	Reserved	

Table 34. 0x0E BUCK2OUT_LIMIT...continued

0x0E – BUCK2OUT_LIMIT				Reset Type	O
Bit	Name	Type	Reset	Description	
6:0	B2_LIMIT	R/W	010 0000	BUCK2 output voltage limit Programmable from 0.60 V to 2.1875 V in 12.5 mV step Default = 1.00 V	

8.2.15 0x0F BUCK3OUT_LIMIT

BUCK3 output voltage limit register. This register is only for PCA9450AA

Table 35. 0x0F BUCK3OUT_LIMIT

0x0F – BUCK3OUT_LIMIT				Reset Type	O
Bit	Name	Type	Reset	Description	
7	RSVD	R/W	0	Reserved	
6:0	B3_LIMIT	R/W	001 1100	BUCK3 output voltage limit Programmable from 0.60 V to 2.1875 V in 12.5 mV step Default = 0.95 V	

8.2.16 0x10 BUCK1CTRL

BUCK1 control register for Ramp, DVS control, Active discharge, FPWM and Enable.

Table 36. 0x10 BUCK1CTRL

0x10 – BUCK1CTRL				Reset Type	O
Bit	Name	Type	Reset	Description	
7:6	RAMP	R/W	01	BUCK1 DVS speed 00b = 25 mV / 1 μ s 01b = 25 mV / 2 μs 10b = 25 mV / 4 μ s 11b = 25 mV / 8 μ s	
5	RSVD	R/W	0	Reserved	
4	DVS_CTRL	R/W	0	DVS Control configuration 0b = BUCK voltage is determined by BUCK1VOUT_DVS0 register regardless of PMIC_STBY_REQ 1b = DVS control through PMIC_STBY_REQ	
3	BUCK1AD	R/W	1	BUCK1 Active discharge 0b = Always disable Active discharge resistor 1b = Enable Active discharge resistor when regulator is OFF	
2	FPWM	R/W	0	Forced PWM mode 0b = Automatic PFM and PWM mode transition 1b = Forced PWM mode	
1:0	B1_ENMODE	R/W	01	BUCK1 enable mode 00b = OFF 01b = ON by PMIC_ON_REQ = H 10b = ON by PMIC_ON_REQ = H && PMIC_STBY_REQ = L 11b = Always ON	

8.2.17 0x11 BUCK1OUT_DVS0

BUCK1 DVS output voltage at PMIC_STBY_REQ = L

Table 37. 0x11 BUCK1OUT_DVS0

0x11 – BUCK1OUT_DVS0				Reset Type	O
Bit	Name	Type	Reset	Description	
7	RSVD	R/W	0	Reserved	
6:0	B1_DVS0	R/W	001 0100	BUCK1 DVS0 Output voltage Programmable from 0.60 V to 2.1875 V in 12.5 mV step. Table 12 Default = 0.85 V	

8.2.18 0x12 BUCK1OUT_DVS1

BUCK1 DVS output voltage at PMIC_STBY_REQ = H

Table 38. 0x12 BUCK1OUT_DVS1

0x12 – BUCK1OUT_DVS1				Reset Type	O
Bit	Name	Type	Reset	Description	
7	RSVD	R/W	0	Reserved	
6:0	B1_DVS1	R/W	001 0100	BUCK1 DVS1 Output voltage Programmable from 0.60 V to 2.1875 V in 12.5 mV step. Table 12 Default = 0.85 V	

8.2.19 0x13 BUCK2CTRL

BUCK2 control register for Ramp, DVS control, Active discharge, FPWM and Enable.

Table 39. 0x13 BUCK2CTRL

0x13 – BUCK2CTRL				Reset Type	O
Bit	Name	Type	Reset	Description	
7:6	RAMP	R/W	01	BUCK2 DVS speed 00b = 25 mV / 1 μ s 01b = 25 mV / 2 μs 10b = 25 mV / 4 μ s 11b = 25 mV / 8 μ s	
5	RSVD	R/W	0	Reserved	
4	DVS_CTRL	R/W	0	DVS Control configuration 0b = BUCK voltage is determined by BUCK2VOUT_DVS0 register regardless of PMIC_STBY_REQ 1b = DVS control through PMIC_STBY_REQ	
3	BUCK2AD	R/W	1	BUCK2 Active discharge 0b = Always disable Active discharge resistor 1b = Enable Active discharge resistor when regulator is OFF	
2	FPWM	R/W	0	Forced PWM mode 0b = Automatic PFM and PWM mode transition 1b = Forced PWM mode	

Table 39. 0x13 BUCK2CTRL...continued

0x13 – BUCK2CTRL				Reset Type	O
Bit	Name	Type	Reset	Description	
1:0	B2_ENMODE	R/W	10	BUCK2 enable mode 00b = OFF 01b = ON by PMIC_ON_REQ = H 10b = ON by PMIC_ON_REQ = H && PMIC_STBY_REQ = L 11b = Always ON	

8.2.20 0x14 BUCK2OUT_DVS0

BUCK2 DVS output voltage at PMIC_STBY_REQ = L

Table 40. 0x14 BUCK2OUT_DVS0

0x14 – BUCK2OUT_DVS0				Reset Type	O
Bit	Name	Type	Reset	Description	
7	RSVD	R/W	0	Reserved	
6:0	B2_DVS0	R/W	001 0100	BUCK2 DVS0 Output voltage Programmable from 0.60 V to 2.1875 V in 12.5 mV step. Table 45 Default = 0.85 V	

8.2.21 0x15 BUCK2OUT_DVS1

BUCK2 DVS output voltage at PMIC_STBY_REQ = H

Table 41. 0x15 BUCK2OUT_DVS1

0x15 – BUCK2OUT_DVS1				Reset Type	O
Bit	Name	Type	Reset	Description	
7	RSVD	R/W	0	Reserved	
6:0	B2_DVS1	R/W	001 0100	BUCK2 DVS1 Output voltage Programmable from 0.60 V to 2.1875 V in 12.5 mV step. Table 45 Default = 0.85 V	

8.2.22 0x16 BUCK3CTRL

BUCK3 control register for Ramp, DVS control, Active discharge, FPWM and Enable.
The registers related to BUCK3 are only for PCA9450AA.

Table 42. 0x16 BUCK3CTRL

0x16 – BUCK3CTRL				Reset Type	O
Bit	Name	Type	Reset	Description	
7:6	RAMP	R/W	01	BUCK3 DVS speed 00b = 25 mV / 1 μ s 01b = 25 mV / 2 μs 10b = 25 mV / 4 μ s 11b = 25 mV / 8 μ s	
5	RSVD	R/W	0	Reserved	

Table 42. 0x16 BUCK3CTRL...continued

0x16 – BUCK3CTRL				Reset Type	O
Bit	Name	Type	Reset	Description	
4	DVS_CTRL	R/W	0	DVS Control configuration 0b = BUCK voltage is determined by BUCK3VOUT_DVS0 register regardless of PMIC_STBY_REQ 1b = DVS control through PMIC_STBY_REQ	
3	BUCK3AD	R/W	1	BUCK3 Active discharge 0b = Always disable Active discharge resistor 1b = Enable Active discharge resistor when regulator is OFF	
2	FPWM	R/W	0	Forced PWM mode 0b = Automatic PFM and PWM mode transition 1b = Forced PWM mode	
1:0	B3_ENMODE	R/W	01	BUCK3 enable mode 00b = OFF 01b = ON by PMIC_ON_REQ = H 10b = ON by PMIC_ON_REQ = H && PMIC_STBY_REQ = L 11b = Always ON	

8.2.23 0x17 BUCK3OUT_DVS0

BUCK3 DVS output voltage at PMIC_STBY_REQ = L

Table 43. 0x17 BUCK3OUT_DVS0

0x17 – BUCK3OUT_DVS0				Reset Type	O
Bit	Name	Type	Reset	Description	
7	RSVD	R/W	0	Reserved	
6:0	B3_DVS0	R/W	001 0100	BUCK3 DVS0 Output voltage Programmable from 0.60 V to 2.1875 V in 12.5 mV step. Table 45 Default = 0.85 V	

8.2.24 0x18 BUCK3OUT_DVS1

BUCK3 DVS output voltage a PMIC_STBY_REQ = H

Table 44. 0x18 BUCK3OUT_DVS1

0x18 – BUCK3OUT_DVS1				Reset Type	O
Bit	Name	Type	Reset	Description	
7	RSVD	R/W	0	Reserved	
6:0	B3_DVS1	R/W	001 0100	BUCK3 DVS1 Output voltage Programmable from 0.60 V to 2.1875 V in 12.5 mV step. Table 45 Default = 0.85 V	

Table 45. BUCK1, BUCK2, BUCK3 Output voltage table

Code	Voltage	Code	Voltage	Code	Voltage	Code	Voltage
0x00	0.6000 V	0x20	1.0000 V	0x40	1.4000 V	0x60	1.8000 V
0x01	0.6125 V	0x21	1.0125 V	0x41	1.4125 V	0x61	1.8125 V
0x02	0.6250 V	0x22	1.0250 V	0x42	1.4250 V	0x62	1.8250 V
0x03	0.6375 V	0x23	1.0375 V	0x43	1.4375 V	0x63	1.8375 V
0x04	0.6500 V	0x24	1.0500 V	0x44	1.4500 V	0x64	1.8500 V
0x05	0.6625 V	0x25	1.0625 V	0x45	1.4625 V	0x65	1.8625 V
0x06	0.6750 V	0x26	1.0750 V	0x46	1.4750 V	0x66	1.8750 V
0x07	0.6875 V	0x27	1.0875 V	0x47	1.4875 V	0x67	1.8875 V
0x08	0.7000 V	0x28	1.1000 V	0x48	1.5000 V	0x68	1.9000 V
0x09	0.7125 V	0x29	1.1125 V	0x49	1.5125 V	0x69	1.9125 V
0x0A	0.7250 V	0x2A	1.1250 V	0x4A	1.5250 V	0x6A	1.9250 V
0x0B	0.7375 V	0x2B	1.1375 V	0x4B	1.5375 V	0x6B	1.9375 V
0x0C	0.7500 V	0x2C	1.1500 V	0x4C	1.5500 V	0x6C	1.9500 V
0x0D	0.7625 V	0x2D	1.1625 V	0x4D	1.5625 V	0x6D	1.9625 V
0x0E	0.7750 V	0x2E	1.1750 V	0x4E	1.5750 V	0x6E	1.9750 V
0x0F	0.7875 V	0x2F	1.1875 V	0x4F	1.5875 V	0x6F	1.9875 V
0x10	0.8000 V	0x30	1.2000 V	0x50	1.6000 V	0x70	2.0000 V
0x11	0.8125 V	0x31	1.2125 V	0x51	1.6125 V	0x71	2.0125 V
0x12	0.8250 V	0x32	1.2250 V	0x52	1.6250 V	0x72	2.0250 V
0x13	0.8375 V	0x33	1.2375 V	0x53	1.6375 V	0x73	2.0375 V
0x14	0.8500 V	0x34	1.2500 V	0x54	1.6500 V	0x74	2.0500 V
0x15	0.8625 V	0x35	1.2625 V	0x55	1.6625 V	0x75	2.0625 V
0x16	0.8750 V	0x36	1.2750 V	0x56	1.6750 V	0x76	2.0750 V
0x17	0.8875 V	0x37	1.2875 V	0x57	1.6875 V	0x77	2.0875 V
0x18	0.9000 V	0x38	1.3000 V	0x58	1.7000 V	0x78	2.1000 V
0x19	0.9125 V	0x39	1.3125 V	0x59	1.7125 V	0x79	2.1125 V
0x1A	0.9250 V	0x3A	1.3250 V	0x5A	1.7250 V	0x7A	2.1250 V
0x1B	0.9375 V	0x3B	1.3375 V	0x5B	1.7375 V	0x7B	2.1375 V
0x1C	0.9500 V	0x3C	1.3500 V	0x5C	1.7500 V	0x7C	2.1500 V
0x1D	0.9625 V	0x3D	1.3625 V	0x5D	1.7625 V	0x7D	2.1625 V
0x1E	0.9750 V	0x3E	1.3750 V	0x5E	1.7750 V	0x7E	2.1750 V
0x1F	0.9875 V	0x3F	1.3875 V	0x5F	1.7875 V	0x7F	2.1875 V

8.2.25 0x19 BUCK4CTRL

BUCK4 control register for Active discharge, FPWM and Enable.

Table 46. 0x19 BUCK4CTRL

0x19 – BUCK4CTRL				Reset Type	O
Bit	Name	Type	Reset	Description	
7:4	RSVD	R/W	0000	Reserved	
3	BUCK4AD	R/W	1	BUCK4 Active discharge 0b = Always disable Active discharge resistor 1b = Enable Active discharge resistor when regulator is OFF	
2	FPWM	R/W	0	Forced PWM mode 0b = Automatic PFM and PWM mode transition 1b = Forced PWM mode	
1:0	B4_ENMODE	R/W	01	BUCK4 enable mode 00b = OFF 01b = ON by PMIC_ON_REQ = H 10b = ON by PMIC_ON_REQ = H && PMIC_STBY_REQ = L 11b = Always ON	

8.2.26 0x1A BUCK4OUT

BUCK4 output voltage configuration register

Table 47. 0x1A BUCK4OUT

0x1A – BUCK4OUT				Reset Type	O
Bit	Name	Type	Reset	Description	
7	RSVD	R/W	0	Reserved	
6:0	B4_OUT	R/W	110 1100	BUCK4 Output voltage Programmable from 0.60 V to 3.40 V in 25 mV step. Table 52 Default = 3.3 V	

8.2.27 0x1B BUCK5CTRL

BUCK5 control register for Active discharge, FPWM and Enable.

Table 48. 0x1B BUCK5CTRL

0x1B – BUCK5CTRL				Reset Type	O
Bit	Name	Type	Reset	Description	
7:4	RSVD	R/W	0000	Reserved	
3	BUCK5AD	R/W	1	BUCK5 Active discharge 0b = Always disable Active discharge resistor 1b = Enable Active discharge resistor when regulator is OFF	
2	FPWM	R/W	0	Forced PWM mode 0b = Automatic PFM and PWM mode transition 1b = Forced PWM mode	
1:0	B5_ENMODE	R/W	01	BUCK5 enable mode 00b = OFF 01b = ON by PMIC_ON_REQ = H 10b = ON by PMIC_ON_REQ = H && PMIC_STBY_REQ = L 11b = Always ON	

8.2.28 0x1C BUCK5OUT

BUCK5 output voltage configuration register

Table 49. 0x1C BUCK5OUT

0x1C – BUCK5OUT				Reset Type	O
Bit	Name	Type	Reset	Description	
7	RSVD	R/W	0	Reserved	
6:0	B5_OUT	R/W	011 0000	BUCK5 Output voltage Programmable from 0.60 V to 3.40 V in 25 mV step. Table 52 Default = 1.8 V	

8.2.29 0x1D BUCK6CTRL

BUCK6 control register for Active discharge, FPWM and Enable.

Table 50. 0x1D BUCK6CTRL

0x1D – BUCK6OUT				Reset Type	O
Bit	Name	Type	Reset	Description	
7:4	RSVD	R/W	0000	Reserved	
3	BUCK6AD	R/W	1	BUCK6 Active discharge 0b = Always disable Active discharge resistor 1b = Enable Active discharge resistor when regulator is OFF	
2	FPWM	R/W	0	Forced PWM mode 0b = Automatic PFM and PWM mode transition 1b = Forced PWM mode	
1:0	B6_ENMODE	R/W	01	BUCK6 enable mode 00b = OFF 01b = ON by PMIC_ON_REQ = H 10b = ON by PMIC_ON_REQ = H && PMIC_STBY_REQ = L 11b = Always ON	

8.2.30 0x1E BUCK6OUT

BUCK6 output voltage configuration register

Table 51. 0x1E BUCK6OUT

0x1E – BUCK6CTRL				Reset Type	O
Bit	Name	Type	Reset	Description	
7	RSVD	R/W	0	Reserved	
6:0	B6_OUT	R/W	001 0100	BUCK6 Output voltage Programmable from 0.60 V to 3.40 V in 25 mV step. Table 52 Default = 1.1 V	

Table 52. BUCK4, BUCK5, BUCK6 Output voltage table

Code	Voltage	Code	Voltage	Code	Voltage	Code	Voltage
0x00	0.600 V	0x20	1.400 V	0x40	2.200 V	0x60	3.000 V
0x01	0.625 V	0x21	1.425 V	0x41	2.225 V	0x61	3.025 V
0x02	0.650 V	0x22	1.450 V	0x42	2.250 V	0x62	3.050 V
0x03	0.675 V	0x23	1.475 V	0x43	2.275 V	0x63	3.075 V
0x04	0.700 V	0x24	1.500 V	0x44	2.300 V	0x64	3.100 V
0x05	0.725 V	0x25	1.525 V	0x45	2.325 V	0x65	3.125 V
0x06	0.750 V	0x26	1.550 V	0x46	2.350 V	0x66	3.150 V
0x07	0.775 V	0x27	1.575 V	0x47	2.375 V	0x67	3.175 V
0x08	0.800 V	0x28	1.600 V	0x48	2.400 V	0x68	3.200 V
0x09	0.825 V	0x29	1.625 V	0x49	2.425 V	0x69	3.225 V
0x0A	0.850 V	0x2A	1.650 V	0x4A	2.450 V	0x6A	3.250 V
0x0B	0.875 V	0x2B	1.675 V	0x4B	2.475 V	0x6B	3.275 V
0x0C	0.900 V	0x2C	1.700 V	0x4C	2.500 V	0x6C	3.300 V
0x0D	0.925 V	0x2D	1.725 V	0x4D	2.525 V	0x6D	3.325 V
0x0E	0.950 V	0x2E	1.750 V	0x4E	2.550 V	0x6E	3.350 V
0x0F	0.975 V	0x2F	1.775 V	0x4F	2.575 V	0x6F	3.375 V
0x10	1.000 V	0x30	1.800 V	0x50	2.600 V	0x70	3.400 V
0x11	1.025 V	0x31	1.825 V	0x51	2.625 V	0x71	3.400 V
0x12	1.050 V	0x32	1.850 V	0x52	2.650 V	0x72	3.400 V
0x13	1.075 V	0x33	1.875 V	0x53	2.675 V	0x73	3.400 V
0x14	1.100 V	0x34	1.900 V	0x54	2.700 V	0x74	3.400 V
0x15	1.125 V	0x35	1.925 V	0x55	2.725 V	0x75	3.400 V
0x16	1.150 V	0x36	1.950 V	0x56	2.750 V	0x76	3.400 V
0x17	1.175 V	0x37	1.975 V	0x57	2.775 V	0x77	3.400 V
0x18	1.200 V	0x38	2.000 V	0x58	2.800 V	0x78	3.400 V
0x19	1.225 V	0x39	2.025 V	0x59	2.825 V	0x79	3.400 V
0x1A	1.250 V	0x3A	2.050 V	0x5A	2.850 V	0x7A	3.400 V
0x1B	1.275 V	0x3B	2.075 V	0x5B	2.875 V	0x7B	3.400 V
0x1C	1.300 V	0x3C	2.100 V	0x5C	2.900 V	0x7C	3.400 V
0x1D	1.325 V	0x3D	2.125 V	0x5D	2.925 V	0x7D	3.400 V
0x1E	1.350 V	0x3E	2.150 V	0x5E	2.950 V	0x7E	3.400 V
0x1F	1.375 V	0x3F	2.175 V	0x5F	2.975 V	0x7F	3.400 V

8.2.31 0x20 LDO_AD_CTRL

LDO active discharge resistor configuration register

Table 53. 0x20 LDO_AD_CTRL

0x20 – LDO_AD_CTRL				Reset Type	O
Bit	Name	Type	Reset	Description	
7	LDO1_AD	R/W	1	LDO1 Active discharge enable 0b = Always disable Active discharge resistor 1b = Enable Active discharge resistor when regulator is OFF	
6	LDO2_AD	R/W	1	LDO2 Active discharge enable 0b = Always disable Active discharge resistor 1b = Enable Active discharge resistor when regulator is OFF	
5	LDO3_AD	R/W	1	LDO3 Active discharge enable 0b = Always disable Active discharge resistor 1b = Enable Active discharge resistor when regulator is OFF	
4	LDO4_AD	R/W	1	LDO4 Active discharge enable 0b = Always disable Active discharge resistor 1b = Enable Active discharge resistor when regulator is OFF	
3	LDO5_AD	R/W	1	LDO5 Active discharge enable 0b = Always disable Active discharge resistor 1b = Enable Active discharge resistor when regulator is OFF	
2	RSVD	R/W	0	Reserved	
1	RSVD	R/W	0	Reserved	
0	RSVD	R/W	0	Reserved	

8.2.32 0x21 LDO1CTRL

LDO1 control register for enable and voltage

Table 54. 0x21 LDO1CTRL

0x21 – LDO1CTRL				Reset Type	O
Bit	Name	Type	Reset	Description	
7:6	ENMODE	R/W	11	LDO1 Enable mode 00b = OFF 01b = ON by PMIC_ON_REQ = H 10b = ON by PMIC_ON_REQ = H && PMIC_STBY_REQ = L 11b = Always ON * When LDO1 is turned off, PCA9450/A transitions to READY mode	
5:3	RSVD	R/W	000	Reserved	

Table 54. 0x21 LDO1CTRL...continued

0x21 – LDO1CTRL				Reset Type	O
Bit	Name	Type	Reset	Description	
2:0	L1_OUT	R/W	010	LDO1 output voltage Programmable from 1.6 V – 1.9 V, 3.0 V – 3.3 V in 100 mV step 000b = 1.6 V 001b = 1.7 V 010b = 1.8 V 011b = 1.9 V 100b = 3.0 V 101b = 3.1 V 110b = 3.2 V 111b = 3.3 V	

8.2.33 0x22 LDO2CTRL

LDO2 control register for enable and voltage

Table 55. 0x22 LDO2CTRL

0x22 – LDO2CTRL				Reset Type	O
Bit	Name	Type	Reset	Description	
7:6	ENMODE	R/W	11	LDO2 Enable mode 00b = OFF 01b = ON by PMIC_ON_REQ = H 10b = ON by PMIC_ON_REQ = H && PMIC_STBY_REQ = L 11b = Always ON * When LDO2 is turned off, PCA9450/A transitions to READY mode	
5:3	RSVD	R/W	000	Reserved	
2:0	L2_OUT	R/W	001	LDO2 output voltage Programmable from 0.8 V to 1.15 V in 50 mV step 000b = 0.8 V 001b = 0.85 V 010b = 0.9 V 011b = 0.95 V 100b = 1.0 V 101b = 1.05 V 110b = 1.1 V 111b = 1.15 V	

8.2.34 0x23 LDO3CTRL

LDO3 control register for enable and voltage

Table 56. 0x23 LDO3CTRL

0x23 – LDO3CTRL				Reset Type	O
Bit	Name	Type	Reset	Description	
7:6	ENMODE	R/W	01	LDO3 Enable mode 00b = OFF 01b = ON by PMIC_ON_REQ = H 10b = ON by PMIC_ON_REQ = H && PMIC_STBY_REQ = L 11b = Always ON	
5	RSVD	R/W	0	Reserved	
4:0	L3_OUT	R/W	0 1010	LDO3 output voltage Programmable from 0.8 V to 3.3 V in 100 mV step, see Table 57	

Table 57. LDO3 output voltage

0x00 : 0.80 V	0x8 : 1.60 V	0x10 : 2.40 V	0x18 : 3.20 V
0x01 : 0.90 V	0x9 : 1.70 V	0x11 : 2.50 V	0x19 : 3.30 V
0x02 : 1.00 V	0xA : 1.80 V	0x12 : 2.60 V	0x1A : 3.30 V
0x03 : 1.10 V	0xB : 1.90 V	0x13 : 2.70 V	0x1B : 3.30 V
0x04 : 1.20 V	0xC : 2.00 V	0x14 : 2.80 V	0x1C : 3.30 V
0x05 : 1.30 V	0xD : 2.10 V	0x15 : 2.90 V	0x1D : 3.30 V
0x06 : 1.40 V	0xE : 2.20 V	0x16 : 3.00 V	0x1E : 3.30 V
0x07 : 1.50 V	0xF : 2.30 V	0x17 : 3.10 V	0x1F : 3.30 V

8.2.35 0x24 LDO4CTRL

LDO4 control register for enable and voltage

Table 58. 0x24 LDO4CTRL

0x24 – LDO4CTRL				Reset Type	O
Bit	Name	Type	Reset	Description	
7:6	ENMODE	R/W	01	LDO4 Enable mode 00b = OFF (PCA9450B/PCA9450C) 01b = ON by PMIC_ON_REQ = H (PCA9450AA) 10b = ON by PMIC_ON_REQ = H && PMIC_STBY_REQ = L 11b = Always ON	
5	RSVD	R/W	0	Reserved	
4:0	L4_OUT	R/W	0 0001	LDO4 output voltage Programmable from 0.8 V to 3.3 V in 100 mV step, see Table 59	

Table 59. LDO4 output voltage

0x00 : 0.80 V	0x8 : 1.60 V	0x10 : 2.40 V	0x18 : 3.20 V
0x01 : 0.90 V	0x9 : 1.70 V	0x11 : 2.50 V	0x19 : 3.30 V
0x02 : 1.00 V	0xA : 1.80 V	0x12 : 2.60 V	0x1A : 3.30 V

Table 59. LDO4 output voltage...continued

0x03 : 1.10 V	0xB : 1.90 V	0x13 : 2.70 V	0x1B : 3.30 V
0x04 : 1.20 V	0xC : 2.00 V	0x14 : 2.80 V	0x1C : 3.30 V
0x05 : 1.30 V	0xD : 2.10 V	0x15 : 2.90 V	0x1D : 3.30 V
0x06 : 1.40 V	0xE : 2.20 V	0x16 : 3.00 V	0x1E : 3.30 V
0x07 : 1.50 V	0xF : 2.30 V	0x17 : 3.10 V	0x1F : 3.30 V

8.2.36 0x25 LDO5CTRL_L

LDO5 control register for enable and voltage when SD_VSEL is low

Table 60. 0x25 LDO5CTRL_L

0x25 – LDO5CTRL_L				Reset Type	O
Bit	Name	Type	Reset	Description	
7:6	ENMODE	R/W	01	LDO5 Enable mode 00b = OFF 01b = ON by PMIC_ON_REQ = H 10b = ON by PMIC_ON_REQ = H && PMIC_STBY_REQ = L 11b = Always ON	
5:4	RSVD	R/W	00	Reserved	
3:0	L5_OUT_L	R/W	1111	LDO5 output voltage when SD_VSEL = Low Programmable from 1.8 V to 3.3 V in 100 mV step, see Table 61	

Table 61. LDO5 output voltage when SD_VSEL = Low

0x00 : 1.80 V	0x4 : 2.20 V	0x8 : 2.60 V	0xC : 3.00 V
0x01 : 1.90 V	0x5 : 2.30 V	0x9 : 2.70 V	0xD : 3.10 V
0x02 : 2.00 V	0x6 : 2.40 V	0xA : 2.80 V	0xE : 3.20 V
0x03 : 2.10 V	0x7 : 2.50 V	0xB : 2.90 V	0xF : 3.30 V

8.2.37 0x26 LDO5CTRL_H

LDO5 control register for enable and voltage when SD_VSEL is High

Table 62. 0x26 LDO5CTRL_H

0x26 – LDO5CTRL_H				Reset Type	O
Bit	Name	Type	Reset	Description	
7:6	RSVD	R/W	00	Reserved	
5:4	RSVD	R/W	00	Reserved	
3:0	L5_OUT_H	R/W	0000	LDO5 output voltage when SD_VSEL = High Programmable from 1.8 V to 3.3 V in 100 mV step, see Table 63	

Table 63. LDO5 output voltage when SD_VSEL = High

0x00 : 1.80 V	0x4 : 2.20 V	0x8 : 2.60 V	0xC : 3.00 V
----------------------	--------------	--------------	--------------

Table 63. LDO5 output voltage when SD_VSEL = High...continued

0x01 : 1.90 V	0x5 : 2.30 V	0x9 : 2.70 V	0xD : 3.10 V
0x02 : 2.00 V	0x6 : 2.40 V	0xA : 2.80 V	0xE : 3.20 V
0x03 : 2.10 V	0x7 : 2.50 V	0xB : 2.90 V	0xF : 3.30 V

8.2.38 0x2A LOADSW_CTRL

Load switch control register for active discharge, short/over current and enable

Table 64. 0x2A LOADSW_CTRL

0x2A – LOADSW_CTRL				Reset Type	O
Bit	Name	Type	Reset	Description	
7	SW_AD	R/W	1	Load switch active discharge 0b = Always disable active discharge resistor 1b = Enable active discharge resistor when it is OFF	
6:5	RSVD	R/W	00	Reserved	
4	SW_SC	R/W	0	When switch detects short circuit current 0b = Turned OFF and set SWEN[1:0] are set to 00b automatically 1b = Turned off and restart in 100 ms	
3:2	SW_OC	R/W	01	When load switch detects over current 00b = Turned OFF and set SWEN[1:0] are set to 00b automatically 01b = Turned off and restart in 100 ms 10b, 11b = stay ON	
1:0	SWEN	R/W	01	SW Enable control 00b = Forced OFF 01b = Enabled by SW_EN pin 10b = Forced ON 11b = Forced ON	

8.2.39 0x2B VRFLT1_STS

Voltage regulator fault status register. It is latched to 1 once corresponding regulator detects fault. If the bit is overwritten to 1, the corresponding bit is newly updated by current status.

Table 65. 0x2B VRFLT1_STS

0x2B – VRFLT1_STS				Reset Type	S
Bit	Name	Type	Reset	Description	
7	SW_OCP	R/W/C	0	Load SW OCP status, deglitched with $t_{DEB_POKB_SW}$ 0 = Load SW doesn't exceed current limit or is OFF 1 = Load SW exceeded current limit	
6	RSVD	R/W/C	0	Reserved	
5	BUCK6_FLT	R/W/C	0	BUCK6 Fault status, deglitched with t_{DEB_POKB} 0b = BUCK6 output is good or BUCK6 is OFF 1b = BUCK6 output falls below 80 % of target	

Table 65. 0x2B VRFLT1_STS...continued

0x2B – VRFLT1_STS				Reset Type	S
Bit	Name	Type	Reset	Description	
4	BUCK5_FLT	R/W/C	0	BUCK5 Fault status, deglitched with t_{DEB_POKB} 0b = BUCK5 output is good or BUCK5 is OFF 1b = BUCK5 output falls below 80 % of target	
3	BUCK4_FLT	R/W/C	0	BUCK4 Fault status, deglitched with t_{DEB_POKB} 0b = BUCK4 output is good or BUCK4 is OFF 1b = BUCK4 output is below 80 %	
2	BUCK3_FLT	R/W/C	0	BUCK3 Fault status, deglitched with t_{DEB_POKB} 0b = BUCK3 output is good or BUCK3 is OFF 1b = BUCK3 output falls below 80 % of target	
1	BUCK2_FLT	R/W/C	0	BUCK2 Fault status, deglitched with t_{DEB_POKB} 0b = BUCK2 output is good or BUCK2 is OFF 1b = BUCK2 output falls below 80 % of target	
0	BUCK1_FLT	R/W/C	0	BUCK1 Fault status, deglitched with t_{DEB_POKB} 0b = BUCK1 output is good or BUCK1 is OFF 1b = BUCK1 output falls below 80 % of target	

8.2.40 0x2C VRFLT2_STS

Voltage regulator fault status register. It is latched to 1 once corresponding regulator detects fault. If the bit is overwritten to 1, the corresponding bit is newly updated by current status.

Table 66. 0x2C VRFLT2_STS

0x2C – VRFLT2_STS				Reset Type	S
Bit	Name	Type	Reset	Description	
7:5	RSVD	R/W/C	000	Reserved	
4	LDO5_FLT	R/W/C	0	LDO5 Fault status, deglitched with t_{DEB_POKB} 0b = LDO5 output is good or LDO5 is OFF 1b = LDO5 output falls below 80 % of target	
3	LDO4_FLT	R/W/C	0	LDO4 Fault status, deglitched with t_{DEB_POKB} 0b = LDO4 output is good or LDO4 is OFF 1b = LDO4 output falls below 80 % of target	
2	LDO3_FLT	R/W/C	0	LDO3 Fault status, deglitched with t_{DEB_POKB} 0b = LDO3 output is good or LDO3 is OFF 1b = LDO3 output falls below 80 % of target	
1	LDO2_FLT	R/W/C	0	LDO2 Fault status, deglitched with t_{DEB_POKB} 0b = LDO2 output is good or LDO2 is OFF 1b = LDO2 output falls below 80 % of target	
0	LDO1_FLT	R/W/C	0	LDO1 Fault status, deglitched with t_{DEB_POKB} 0b = LDO1 output is good or LDO1 is OFF 1b = LDO1 output falls below 80 % of target	

8.2.41 0x2D VRFLT1_MASK

VR fault mask bit. Once the bit is masked, PCA9450 doesn't enter Fault shutdown even if fault condition of corresponding regulator happens

Table 67. 0x2D VRFLT1_MASK

0x2D – VRFLT1_MASK				Reset Type	S
Bit	Name	Type	Reset	Description	
7	RSVD	R/W	0	Reserved	
6	RSVD	R/W	0	Reserved	
5	BUCK6_FLT_M	R/W	1	BUCK6 FLT mask 0b = Unmask 1b = Masked	
4	BUCK5_FLT_M	R/W	1	BUCK5 FLT mask 0b = Unmask 1b = Masked	
3	BUCK4_FLT_M	R/W	1	BUCK4 FLT mask 0b = Unmask 1b = Masked	
2	BUCK3_FLT_M	R/W	1	BUCK3 FLT mask 0b = Unmask 1b = Masked	
1	BUCK2_FLT_M	R/W	1	BUCK2 FLT mask 0b = Unmask 1b = Masked	
0	BUCK1_FLT_M	R/W	1	BUCK1 FLT mask 0b = Unmask 1b = Masked	

8.2.42 0x2E VRFLT2_MASK

VR fault mask bit. Once the bit is masked, PCA9450 doesn't enter Fault shutdown even if fault condition of corresponding regulator happens

Table 68. 0x2E VRFLT2_MASK

0x2E – VRFLT2_MASK				Reset Type	S
Bit	Name	Type	Reset	Description	
7	RSVD	R/W/C	0	Reserved	
6	RSVD	R/W/C	0	Reserved	
5	RSVD	R/W/C	0	Reserved	
4	LDO5_FLT_M	R/W	1	LDO5 FLT mask 0b = Unmask 1b = Masked	
3	LDO4_FLT_M	R/W	1	LDO4 FLT mask 0b = Unmask 1b = Masked	

Table 68. 0x2E VRFLT2_MASK...continued

0x2E – VRFLT2_MASK				Reset Type	S
Bit	Name	Type	Reset	Description	
2	LDO3_FLT_M	R/W	1	LDO3 FLT mask 0b = Unmask 1b = Masked	
1	LDO2_FLT_M	R/W	1	LDO2 FLT mask 0b = Unmask 1b = Masked	
0	LDO1_FLT_M	R/W	1	LDO1 FLT mask 0b = Unmask 1b = Masked	

9 Application design-in information

9.1 Reference schematic

9.1.1 PCA9450AA reference schematic

PCA9450AA reference schematic with i.MX 8M Mini is illustrated in [Figure 21](#).

Power management IC for i.MX 8M application processor family

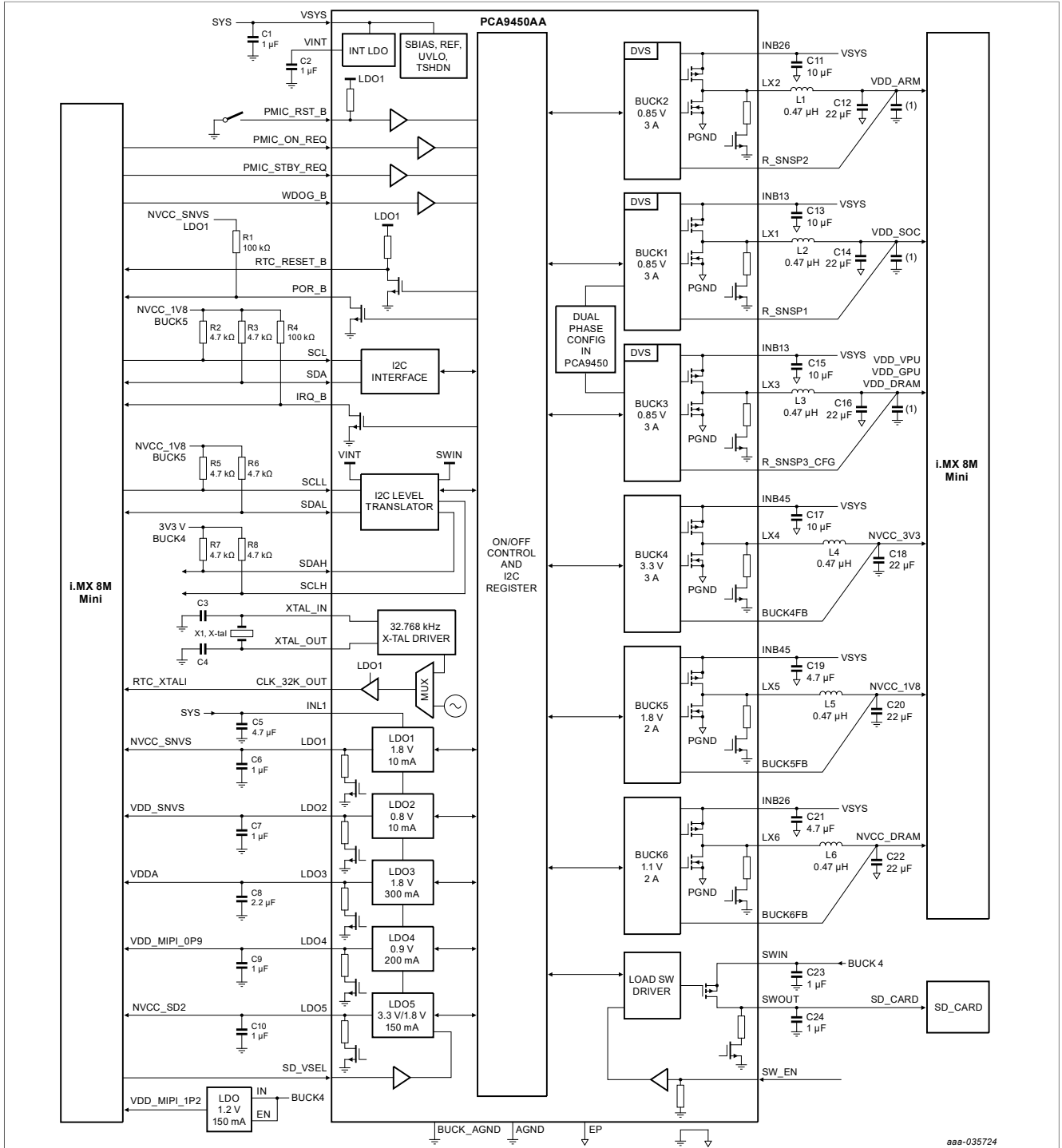

(1) This capacitor is decoupling capacitor in MCU side.

Figure 21. PCA9450AA application schematic

9.1.2 PCA9450B reference schematic

PCA9450B reference schematic with i.MX 8M Nano is illustrated in Figure 22.

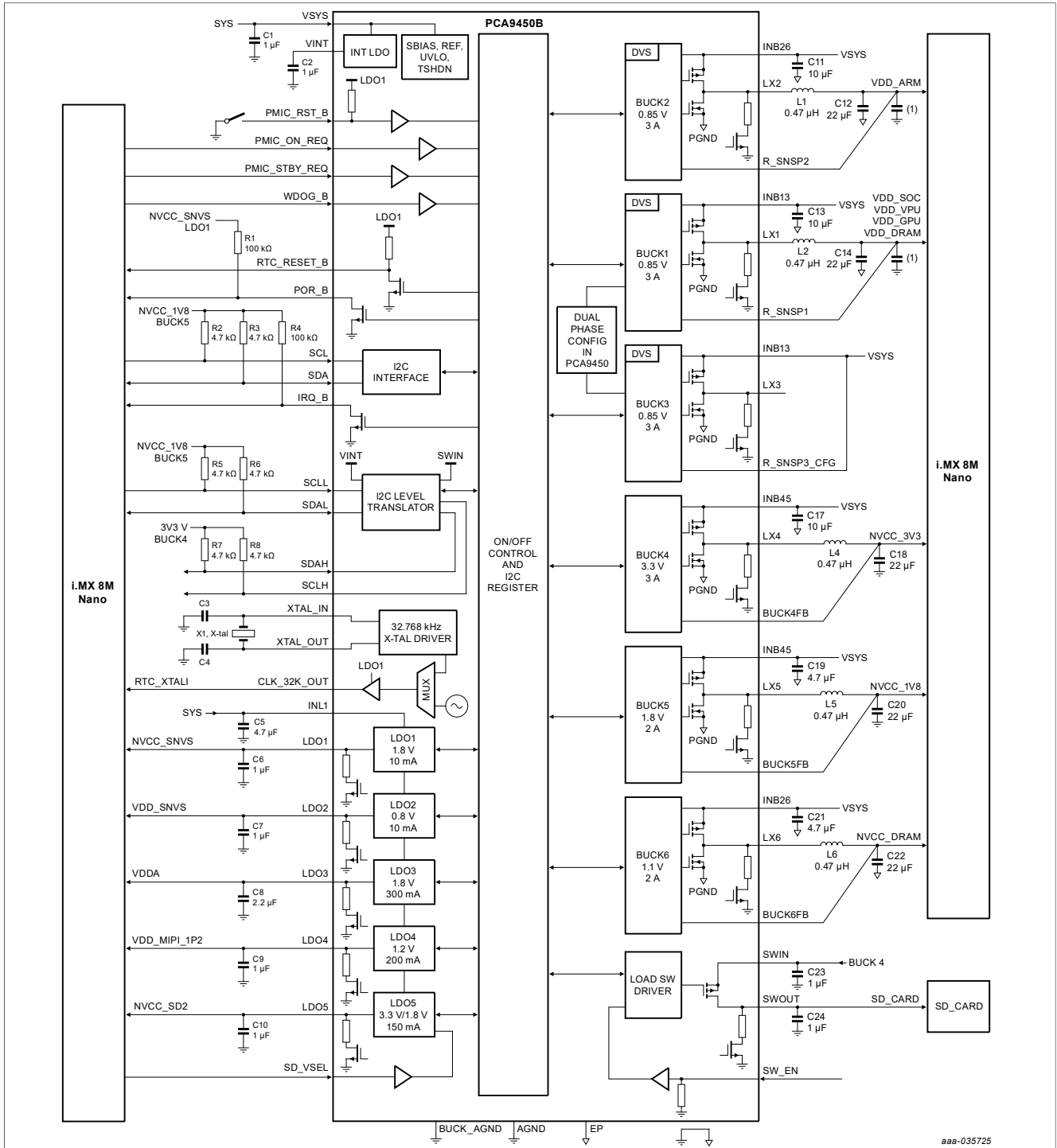

(1) This capacitor is decoupling capacitor in MCU side.

Figure 22. PCA9450B application schematic

9.1.3 PCA9450C reference schematic

PCA9450C reference schematic with i.MX 8M Plus is illustrated in [Figure 23](#)

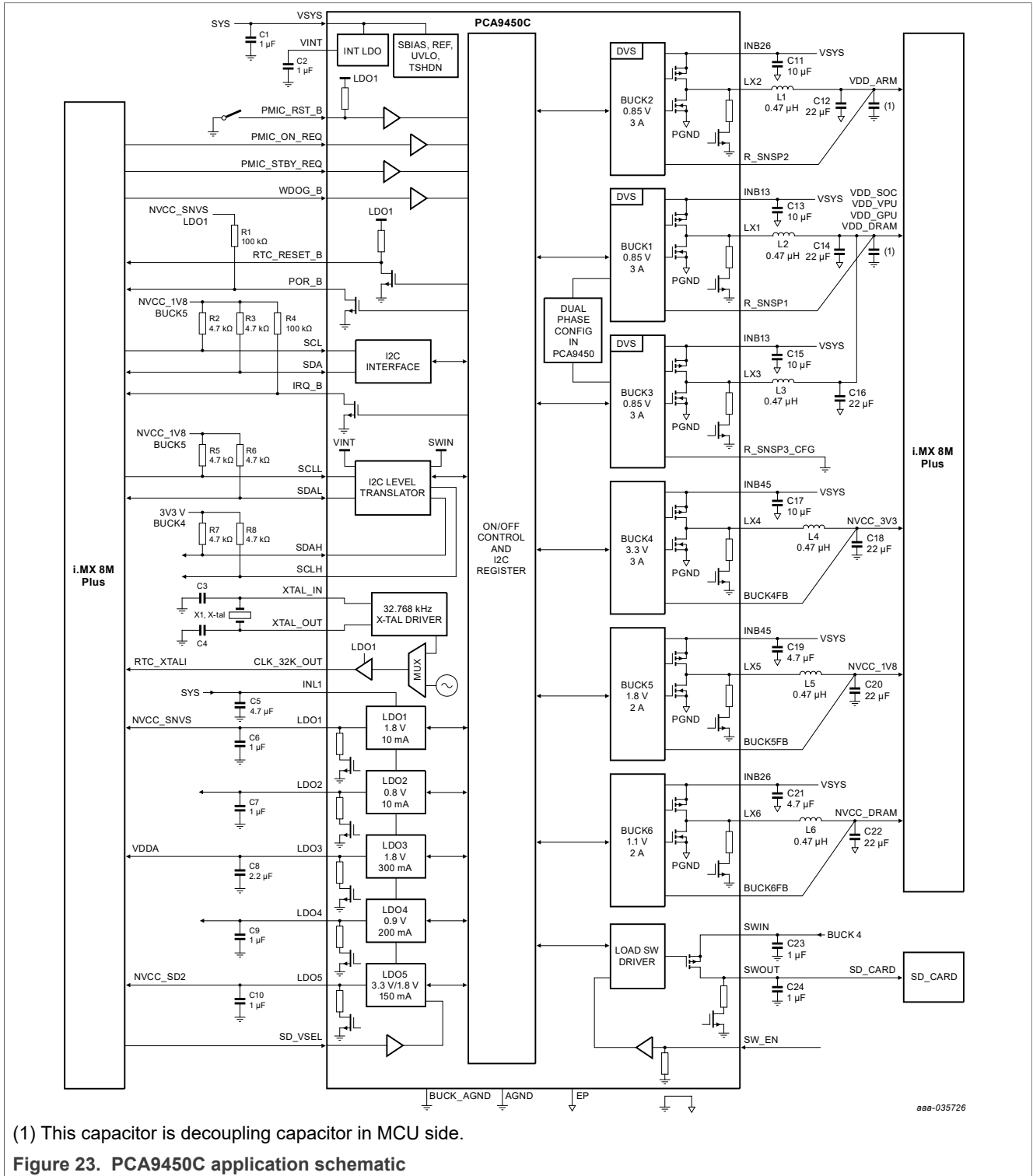

9.2 Typical application

Please follow the recommendations below for your schematic/PCB layout design:

- 1 μF bypass capacitor on VINT and VSYS, located as close as possible to those pins to ground
- Input capacitors must be present on the INB and INL supplies if used
- Output inductors and capacitors must be used on the outputs of the BUCK converters if used
- Output capacitors must be used on the outputs of the LDOs

9.2.1 Buck regulators

9.2.1.1 Inductor selection for buck converters

Each of the converters on PCA9450 typically uses a 0.47 μH output inductor which has to be rated for its DC resistance and saturation current. The DC resistance of the inductance influences directly the efficiency of the converter. Therefore, an inductor with lowest DC resistance must be selected for highest efficiency.

Equation 1 calculates the maximum inductor current under static load conditions. The saturation current of the inductor must be rated higher than the maximum inductor current as calculated with Equation 2. This is needed because during heavy load transient the inductor current rises above the calculated value.

$\Delta I_L = V_{out} \times \frac{1 - \frac{V_{out}}{V_{inmax}}}{L \times f}$	(1)
$I_{Lmax} = I_{out,max} + \frac{\Delta I_L}{2}$	(2)

Where

- f = switching frequency (2 MHz)
- L = Inductance
- ΔI_L = Peak to peak inductor ripple current
- I_{L,max} = Maximum inductor current

A conservative approach is to select the inductor current rating just for the maximum switch current of the PCA9450

[Table 69](#) shows possible inductors list.

Table 69. Tested inductor list

Buck	Vendor	Part number	Size	DCR [mΩ]	Isat [A]	Itemp [A]
BUCK1, BUCK2, BUCK3, BUCK4	Sunlord	WPN252012HR47MT	2520	29	5.6	4.0
	Murata	1239AS-H-R47M	2520	39	3.8	3.7
BUCK5, BUCK6	Sunlord	WPN201610UR47MT	2016	28	5.0	4.1

Table 69. Tested inductor list...continued

Buck	Vendor	Part number	Size	DCR [mΩ]	Isat [A]	Itemp [A]
	Murata	1286AS-H-R47M	2016	52	3.4	3.2

9.2.1.2 Output capacitor selection for buck converters

The fast response adaptive constant ON time control scheme of the buck converters implemented on PCA9450 allows the use of a single typical 22 μF ceramic capacitor for each converter output without compromising on output overshoot/undershoot voltage ripple during heavy load transients. Ceramic capacitors having low ESR values have the lowest output voltage ripple and are recommended.

If ceramic output capacitors are used, the capacitor RMS ripple current rating always meets the application requirements. Just for completeness, the RMS ripple current is calculated in Equation 3.

$$I_{RMS.COUT} = V_{out} \times \frac{1 - \frac{V_{out}}{V_{in}}}{L \times f} \times \frac{1}{2\sqrt{3}} \tag{3}$$

At nominal load current, the inductive converters operate in PWM mode. The overall output voltage ripple is the sum of the voltage spike caused by the output capacitor ESR plus the voltage ripple caused by charging and discharging the output capacitor:

$$\Delta V_{out} = V_{out} \times \frac{1 - \frac{V_{out}}{V_{in}}}{L \times f} \times \left(\frac{1}{8 \times C_{out} \times f} + ESR \right) \tag{4}$$

Where

- The highest output voltage ripple occurs at the highest input voltage Vin.

At light load currents, the converters operate in PFM mode and the output voltage ripple is dependent on the output capacitor value. The output voltage ripple is set by the internal comparator delay and the external capacitor. The typical output voltage ripple is less than 1 % of the nominal output voltage.

9.2.1.3 Input capacitor selection for buck converters

Low ESR input capacitor is highly recommended for best input voltage filtering and minimizing the interference with other circuits caused by high input voltage spikes because of the nature of buck converter. Each DC-DC converter requires a 10 μF ceramic input capacitor on its input pins. The input capacitor could be increased without any limit for better input voltage filtering.

9.2.2 Crystal oscillator

9.2.2.1 Crystal selection

The most important parameters when choosing a crystal are:

- Crystal's required effective load capacitance (typically 6 pF to 15 pF)
- Crystal's ESR (typically 30 kΩ to 100 kΩ)
- Tolerance (typically 5 ppm to 30 ppm)

All of these crystal parameters can usually be found in the crystal datasheet.

9.2.2.2 Effective load capacitance

The crystal oscillator (see [Figure 24](#)) uses two load capacitors, C_{L1} and C_{L2}, as load for the crystal. These capacitors generate, together with the crystal's inductance, the required 180° phase shift of the feedback loop.

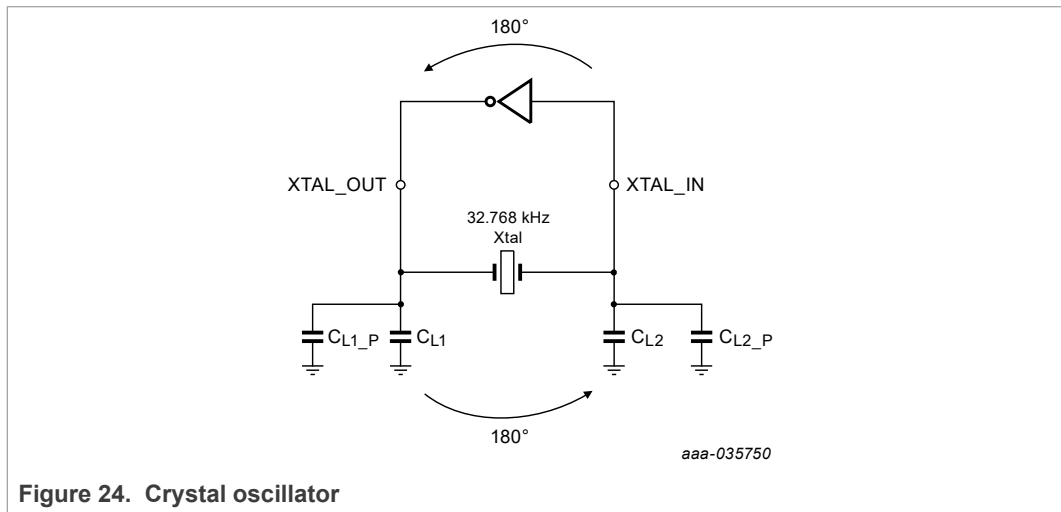

Figure 24. Crystal oscillator

From the view of the crystal, these capacitors are a serial connection through GND. Hence, if using two equal capacitors, the values of these capacitors must be twice the required load capacitance. It is also important to consider PCB parasitic capacitances for the calculation of the necessary capacitors according to Equation 5.

$C_{LOAD} = \frac{C'_{L1} \times C'_{L2}}{C'_{L1} + C'_{L2}}$	(5)
---	-----

Where:

- C'_{L1} = C_{L1} + C_{L1_P}, C_{L1_P} is PCB parasitic capacitance.
- C'_{L2} = C_{L2} + C_{L2_P}, C_{L2_P} is PCB parasitic capacitance.

When using equal capacitors for C_{L1} and C_{L2} and a symmetric layout with equal parasitic capacitance on both crystal pins, the effective load capacitance is shown in Equation 6.

$C_{LOAD} = (C_{L1} + C_{L1_P}) / 2$	(6)
--------------------------------------	-----

Example:

Crystal requires 12 pF load.

Parasitic capacitance per pin is 2 pF.

$$C_{L1} = (2 \times C_{Load}) - C_{L1_P} = (2 \times 12 \text{ pF}) - 2 \text{ pF} = 22 \text{ pF}$$

$$C_{L2} = C_{L1} = 22 \text{ pF}$$

9.2.2.3 Frequency tuning

The crystal oscillator frequency is very much dependent on the load capacitance that is connected. Therefore, measuring the oscillator frequency gives a good indication if the load capacitors that are used match the crystal requirements. This measurement also automatically includes the parasitic PCB and pin capacitances of the application.

It is strongly recommended not to measure the oscillator frequency directly at the crystal pins. The capacitance at the crystal pins is in the range of 10 pF, and the impedance on this signal line is several megaohms. A typical passive probe has a capacitance in the range of 10 pF and an input impedance of approximately 10 MΩ. Both values are in the range of the oscillator characteristics and heavily influence the behavior of the crystal oscillators. Instead, it is recommended to measure frequency at CLK_32K_OUT pin.

Assuming the crystal itself has no tolerance, too low a capacitive load results in a higher oscillator frequency than expected and, vice versa, the frequency is lower than the nominal value, if the load is too high. Therefore, if the oscillation frequency is too high, the value of load capacitors must be increased. When too low frequency is measured, it is necessary to decrease the value of the load capacitors. Comparing the finally optimized capacitors with the crystal data sheet value for load capacitance gives the parasitic capacitance added by the PCB layout and pins.

9.3 Layout guide

Layout guide is shown in [Figure 25](#).

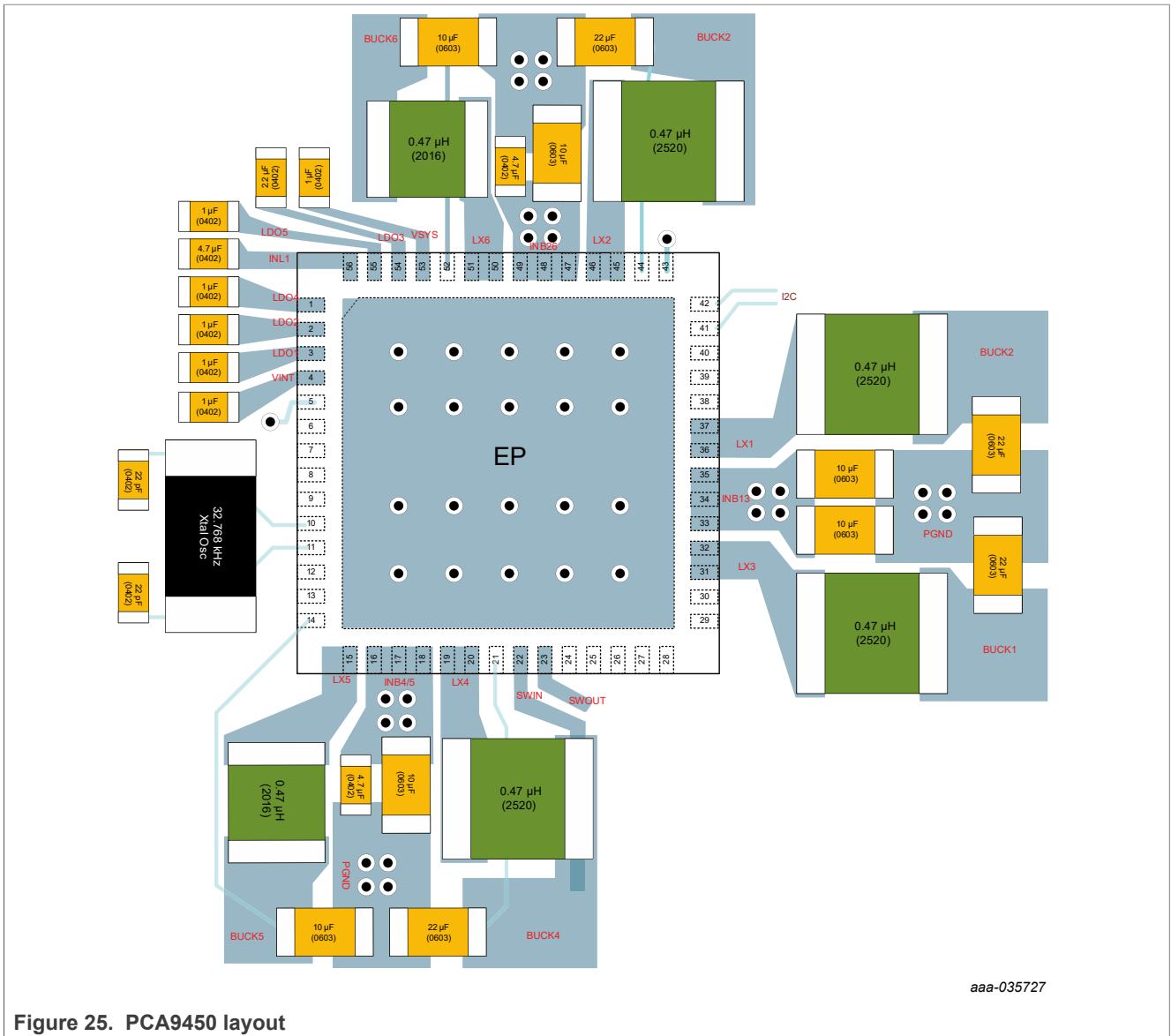

10 Limiting values

Table 70. Limiting values
(Absolute maximum ratings)

Explanation	Pin	Conditions	Min	Max	Unit
Voltage range (with respect to EP)	VSYS, INB13, INB26, INB45, INL1, SWIN		-0.5	+6.0	V
	SWOUT		-0.5	SWIN + 0.5	V
	LX1, LX3		-0.5	INB13 + 0.5	V
	LX2, LX6		-0.5	INB26 + 0.5	V
	LX4, LX5		-0.5	INB45 + 0.5	V
	R_SNSP1, R_SNSP2, R_SNSP3_CFG		-0.5	VSYS + 0.5	V
	BUCK_AGND, AGND		-0.5	+0.5	V
	BUCK4FB, BUCK5FB, BUCK6FB		-0.5	VSYS + 0.5	V
	LDO1, LDO2, LDO3, LDO4, LDO5		-0.5	V _{INL1} + 0.5	V
	XTAL_IN, XTAL_OUT		-0.5	VSYS + 0.5	V
	RTC_RESET_B, PMIC_RST_B, CLK_32K_OUT		-0.5	LDO1 + 0.5	V
	PMIC_ON_REQ, POR_B, PMIC_STBY_REQ, WDOG_B, IRQ_B, SCL, SDA, SD_VSEL, SW_EN		-0.5	VSYS + 0.5	V
	SCLH, SDAH		-0.5	SWIN + 0.5	V
	SCLL, SDAL		-0.5	VINT + 0.5	V
VINT		-0.5	+2.0	V	
Output Current	LX1, LX2, LX3, LX4	RMS current		5.0	A
	LX5, LX6	RMS current		4.0	A
	SWIN, SWOUT	RMS current		0.5	A
Junction temperature			-40	+150	°C
V _{ESD}	All pins	HBM (JESD22-001)	-2	+2	kV
		CDM (JESD22-C101E)	-500	+500	V

11 Recommended operating conditions

Table 71. Recommended Operating Conditions

Explanation	Pin	Conditions	Min	Max	Unit
Voltage range (with respect to EP)	VSYS, INL1		2.7	5.5	V
	INB13, INB26, INB45		2.7	5.5	V
	SWIN		2.7	5.5	V
Junction temperature			-40	+125	°C
Ambient temperature			-40	+105	°C

12 Thermal characteristics

Table 72. Thermal characteristics

Symbol	Parameter	Conditions		Typ	Unit
Rth(j-a)	thermal resistance from junction to ambient		[1] [2]	32.1	°C/W

[1] Determined in accordance to JEDEC JESD51-2A natural convection environment. Thermal resistance data in this report is solely for a thermal performance comparison of one package to another in a standardized specified environment. It is not meant to predict the performance of a package in an application-specific environment

[2] Thermal test board meets JEDEC specification for this package (JESD51-9)

13 Electrical characteristics

13.1 Top level parameter

Table 73. Top level parameter

Unless otherwise specified, $V_{SYS} = 3.8\text{ V}$, $V_{INBx} = 3.8\text{ V}$, $V_{INL1} = 3.8\text{ V}$, $T_{amb} = -40\text{ °C} \sim +105\text{ °C}$

Symbol	Parameter	Conditions	Min	Typ	Max	Unit
Quiescent Current						
I_{Q_SNVS}	VSYS SNVS Current	LDO1 and LDO2 are ON and no load, other regulators are OFF, CLK_32K_OUT enabled, PMIC_ON_REQ = L, $T_{amb} = 25\text{ °C}$		23	50	μA
		LDO1 and LDO2 are ON and no load, other regulators are OFF, CLK_32K_OUT enabled, PMIC_ON_REQ = L, $T_{amb} = -40\text{ °C} \sim 105\text{ °C}$		23	120	μA
$I_{Q_STADNDBY}$	VSYS Standby current	LDO1, LDO2, LDO3, LDO4, LDO5, BUCK1, BUCK3, BUCK4, BUCK5, BUCK6 are ON and no load. PMIC_ON_REQ = H, PMIC_STBY_REQ = H		220	350	μA
VSYS						
V_{SYS_UVLO}	VSYS UVLO	VSYS Rising	2.85	3.0	3.15	V
$V_{SYS_UVLO_H}$	VSYS UVLO Hysteresis	VSYS Falling		200		mV
V_{SYS_POR}	VSYS POR	VSYS Rising	2.2	2.4	2.6	V
$V_{SYS_POR_H}$	VSYS POR Hysteresis	VSYS Falling		200		mV
VINT						
V_{INT}	Internal Power supply LDO	$V_{SYS} = 3.8\text{ V}$	1.7	1.8	1.9	V
Low VSYS						
V_{LOW_VSYS}	Low VSYS	Low VSYS threshold above V_{SYS_UVLO} , $LOW_VSYS [7:6] = 01b$	150	200	250	mV
$V_{LOW_VSYS_HYS}$	Low VSYS Hysteresis			110		mV
Thermal Shutdown						
T_{JSHDN}	Thermal Shutdown	T_j Rising, 15 °C hysteresis		150		$^{\circ}\text{C}$
T_{J105}	Thermal interrupt1	T_j Rising, 15 °C hysteresis	95	105	125	$^{\circ}\text{C}$
T_{J125}	Thermal interrupt2	T_j Rising, 15 °C hysteresis	115	125	145	$^{\circ}\text{C}$
Logic and Control signals						
V_{IL}	Input Low level	PMIC_ON_REQ, PMIC_STBY_REQ, WDOG_B, SD_VSEL, SW_EN, PMIC_RST_B			0.4	V

Table 73. Top level parameter...continued

Unless otherwise specified, VSYS = 3.8 V, VINBx = 3.8 V, VINL1 = 3.8 V, Tamb = -40 °C ~ +105 °C

Symbol	Parameter	Conditions	Min	Typ	Max	Unit
V _{IH}	Input High level	PMIC_ON_REQ, PMIC_STBY_REQ, WDOG_B, SD_VSEL, SW_EN, PMIC_RST_B	1.4			V
I _{LEAK}	Logic Input leakage current	PMIC_ON_REQ, PMIC_STBY_REQ, WDOG_B, SD_VSEL: V _{Logic} = 5.5 V, VSYS = 5.5 V	-0.5		+0.5	µA
R _{PD}	Internal Pull-down resistor	SW_EN		1.2		MΩ
V _{OL}	Output Low level	RTC_RESET_B, IRQB, POR_B, I _{OL} = 6 mA			0.4	V
R _{PU}	Internal Pull-up resistor	RTC_RESET_B, PMIC_RST_B to LDO1		100		KΩ
Logic signal (PCA9450B/ PCA9450C)						
V _{IL}	Input Low level	R_SNSP3_CFG			0.4	V
V _{IH}	Input High level	R_SNSP3_CFG	1.4			V
I _{LEAK}	Logic Input leakage current	R_SNSP3_CFG V _{Logic} = 5.5 V, VSYS = 5.5 V	-1		+1	µA
Timing spec						
t _{DEB_POKB}	Debounce time of regulator POKB		320	400	480	µs
t _{DEB_POKB_SW}	Debounce time of Load SW POKB		240	300	360	µs
t _{DEB_WDOGB}	Debounce time of WDOG_B		90	120	150	µs
t _{DEB_PMIC_RST_B}	Debounce time of PMIC_RST_B	T_PMIC_RST_DEB[2:0] = 001b	40	50	60	ms
t _{SNVS_PU}	Time to 90 % of LDO1 from VSYS UVLO detected		16	20	24	ms
t _{RTC_RST}	Time to RTC_RESET_B release from LDO2 POK		16	20	24	ms
t _{32K_EN}	Time to 32K buffer enable from LDO2 POK		8	10	12	ms
t _{RTC_TRAN}	Time to transition to Xtal osc after RTC_RESET_B release		0.8	1	1.2	sec
t _{ON_DEB}	PMIC_ON_REQ high debounce time	Programmable, Ton_Deb[1:0] = 01b	16	20	24	ms
t _{STEP}	Time step to turn on each regulator	Programmable, Tstep[1:0] = 01b	1.6	2	2.4	ms
t _{OFF_STEP}	Time step to turn off each regulator	Programmable, Toff_step[1:0] = 10b	6	8	10	ms

Table 73. Top level parameter...continued

Unless otherwise specified, $V_{SYS} = 3.8\text{ V}$, $V_{INBx} = 3.8\text{ V}$, $V_{INL1} = 3.8\text{ V}$, $T_{amb} = -40\text{ °C} \sim +105\text{ °C}$

Symbol	Parameter	Conditions	Min	Typ	Max	Unit
t_{OFF_DEB}	PMIC_ON_REQ low debounce time	Programmable, Toff_Deb = 0b	90	120	150	μs
t_{PORB}	Time from LDO5 POK to POR_B release during Power on seq		16	20	24	ms
$t_{FLT_SD_PU}$	Fault time to POK after regulator enable during power up sequence	At power up sequence	8	10	12	ms
$t_{FLT_POK_MSK}$	POK mask time when regulator is enabled at RUN/Standby mode		1.6	2	2.4	ms
t_{FLT_THSD}	Time to enter FAULT_SD when thermal Fault occurs		170	210	250	μs
$t_{FLT_SD_STAY}$	Time to stay at FAULT_SD to move other mode		80	100	120	ms
$t_{FLT_SD_WAIT}$	Wait time to enter FAULT_SD after fault interrupt	At Standby and Run mode, programmable, $t_{FLT_SD_WAIT} = 0b1$	80	100	120	ms
$t_{RESTART}$	Wait time to start power up after power down at cold reset	Programmable, Trestart = 0b	200	250	300	ms
t_{WRESET}	POR_B low time at Warm reset		16	20	24	ms

13.2 I2C level translator

Table 74. I2C level translator

Unless otherwise specified, $V_{SYS} = 3.8\text{ V}$, $V_{INBx} = 3.8\text{ V}$, $V_{INL1} = 3.8\text{ V}$, $T_{amb} = -40\text{ °C} \sim +105\text{ °C}$

Symbol	Parameter	Conditions	Min	Typ	Max	Unit
VDDH	Operating voltage	Internally tied to SWIN	2.7		5.5	V
I _{VDDH}	Shutdown current	SWIN = 3.3 V, I2C_LT_EN bit = 0b		1	5	μA
I _{VDDH}	Active current	SWIN = 3.3 V, I2C_LT_EN bit = 1b, SCLL, SDAL = 1.8 V		60	90	μA
I _{VDDH}	Active current	SWIN = 3.3 V, I2C_LT_EN bit = 1b, SCLL, SDAL = 0 V		715	850	μA
V _{IH}	High level input voltage	SWIN = 3.3 V, I2C_LT_EN bit = 1b	V _{INT} – 0.2			V
V _{IL}	Low level input voltage	SWIN = 3.3 V, I2C_LT_EN bit = 1b			0.15	V
V _{OH}	High level output voltage	SWIN = 3.3 V, I2C_LT_EN bit = 1b, I _{OL} = 20 μA	0.75 * SWIN			V
V _{OL}	Low level output voltage	SWIN = 3.3 V, I2C_LT_EN bit = 1b, I _{OL} = 1 mA			0.4	V
C _{I/O} ^[1]	Input Output capacitance	SWIN = 3.3 V		5		pF
t _{PHL} ^[1]	High to Low propagation delay	SWIN = 3.3 V, SCL/SDA to SCLH/SDAH		4.0	4.7	ns
t _{PLH} ^[1]	Low to High propagation delay	SWIN = 3.3 V, SCL/SDA to SCLH/SDAH		5.0	6.8	ns
t _{PHL} ^[1]	High to Low propagation delay	SWIN = 3.3 V, SCLH/SDAH to SCL/SDA		4.0	4.5	ns
t _{PLH} ^[1]	Low to High propagation delay	SWIN = 3.3 V, SCLH/SDAH to SCL/SDA		4.0	4.5	ns
t _{en} ^[1]	Enable time	SWIN = 3.3 V, from I2C enable		100		μs
f _{data} ^[1]	Data rate				20	Mbps

[1] Guaranteed by design

13.3 BUCK1 (PCA9450AA/PCA9450B)

Table 75. BUCK1 (PCA9450AA/PCA9450B)

Unless otherwise specified, $V_{SYS} = 3.8\text{ V}$, $V_{INBx} = 3.8\text{ V}$, $V_{INL1} = 3.8\text{ V}$, $V_{BUCK1} = 0.85\text{ V}$, $C_{OUT} = 22\text{ }\mu\text{F}$, $T_{amb} = -40\text{ }^{\circ}\text{C} \sim +105\text{ }^{\circ}\text{C}$

Symbol	Parameter	Conditions	Min	Typ	Max	Unit
V_{INB13}	Input voltage range	INB13 pin	2.85		5.5	V
$I_{Shutdown}$	Shutdown current	Regulator disabled, $V_{INB13} = 5.0\text{ V}$		0.1		μA
I_Q	Quiescent current	Regulator enabled, No load, No switching		20		μA
I_{OUT_MAX}	Max Output Current		3000			mA
V_{BUCK1}	Programmable Output voltage range	I2C programmable, 12.5 mV step	0.6		2.1875	V
V_{BUCK1_OUT}	DC Output Voltage Accuracy	$V_{INB13} = 3.8\text{ V}$, $V_{BUCK1_OUT} = 0.85\text{ V}$, $I_{OUT} = 0\text{ A}$, FPWM mode, $25\text{ }^{\circ}\text{C}$	-0.6		+0.6	%
		$V_{INB13} = 3.8\text{ V}$, $V_{BUCK1_OUT} = 0.85\text{ V}$, $I_{OUT} = 0\text{ A}$, FPWM mode	-2		+2	%
$\Delta V_{OUT(\Delta V_{INB})}^{[1]}$	DC Line regulation	$V_{INB13} = 3\text{ V}$ to 5 V , $I_{OUT} = I_{OUT_MAX}$		2		mV/V
$\Delta V_{OUT(\Delta I_{OUT})}^{[1]}$	DC Load regulation	$0\text{ mA} < I_{OUT} < I_{OUT_MAX}$, $V_{BUCK1_OUT} = 0.85\text{ V}$		3		mV/A
$\Delta V_{OUT(\Delta I_{OUT})}^{[1]}$	Transient Load Response	I_{OUT} changes 0 to I_{OUT_MAX} (1 A/ μs slope), $V_{BUCK1_OUT} = 0.85\text{ V}$		50		mV
$\Delta V_{OUT}^{[1]}$	Output voltage Ripple	FPWM mode		10		mV
f_{sw}	Switching Frequency in CCM			2		MHz
R_{DSON}	High Side P-FET R_{DSON}	$V_{INB13} = 3.8\text{ V}$, including bonding wire		87		$\text{m}\Omega$
	Low Side N-FET R_{DSON}	$V_{INB13} = 3.8\text{ V}$, including bonding wire		45		$\text{m}\Omega$
I_{LIM}	High side current limit	$V_{INB13} = 3.8\text{ V}$	4.0	4.5	5.0	A
	Low side current limit	$V_{INB13} = 3.8\text{ V}$	2.5	3.0	3.7	A
$t_{START}^{[1]}$	Startup time	EN rising to 90 % of output voltage		250	500	μs
$V_{RAMP}^{[1]}$	Output voltage slew rate	Programmable, RAMP[1:0] = 01b		12.5		mV/ μs
$V_{soft_strup}^{[1]}$	Soft-start slew rate			12.5		mV/ μs
R_{DIS}	Output Active Discharge Resistance			100	150	Ω
POK	Output Power good			85	95	%
$L^{[1]}$	Inductor value			0.47		μH
$C_{OUT}^{[1]}$	Output capacitance	Minimum nominal capacitance	22			μF

[1] Guaranteed by design

13.4 Dual Phase BUCK1 (PCA9450C)

Table 76. Dual Phase BUCK1 (PCA9450C)

Unless otherwise specified, $V_{SYS} = 3.8\text{ V}$, $V_{INBx} = 3.8\text{ V}$, $V_{INL1} = 3.8\text{ V}$, $V_{BUCK1} = 0.85\text{ V}$, $C_{OUT} = 44\text{ }\mu\text{F}$, $T_{amb} = -40\text{ }^{\circ}\text{C} \sim +105\text{ }^{\circ}\text{C}$

Symbol	Parameter	Conditions	Min	Typ	Max	Unit
V_{INB13}	Input voltage range	INB13 pin	2.85		5.5	V
$I_{Shutdown}$	Shutdown current	Regulator disabled, $V_{INB13} = 5.0\text{ V}$		0.2		μA
I_Q	Quiescent current	Regulator enabled, No load, No switching		20		μA
I_{OUT_MAX}	Max Output Current		6000			mA
V_{BUCK1}	Programmable Output voltage range	I2C programmable, 12.5 mV step	0.6		2.1875	V
V_{BUCK1_OUT}	DC Output Voltage Accuracy	$V_{INB13} = 3.8\text{ V}$, $V_{BUCK1_OUT} = 0.85\text{ V}$, $I_{OUT} = 0\text{ A}$, FPWM mode, $25\text{ }^{\circ}\text{C}$	-0.6		+0.6	%
		$V_{INB13} = 3.8\text{ V}$, $V_{BUCK1_OUT} = 0.85\text{ V}$, $I_{OUT} = 0\text{ A}$, FPWM mode	-2		+2	%
$\Delta V_{OUT(\Delta V_{INB})}^{[1]}$	DC Line regulation	$V_{INB13} = 3\text{ V}$ to 5 V , $I_{OUT} = I_{OUT_MAX}$		2		mV/V
$\Delta V_{OUT(\Delta I_{OUT})}^{[1]}$	DC Load regulation	$0\text{ mA} < I_{OUT} < I_{OUT_MAX}$, $V_{BUCK1_OUT} = 0.85\text{ V}$		3		mV/A
$\Delta V_{OUT(\Delta I_{OUT})}^{[1]}$	Transient Load Response	I_{OUT} changes 0 to I_{OUT_MAX} (1 A/ μs slope), $V_{BUCK1_OUT} = 0.85\text{ V}$		50		mV
$\Delta V_{OUT}^{[1]}$	Output voltage Ripple	FPWM mode		10		mV
f_{SW}	Switching Frequency in CCM			2		MHz
R_{DSON}	High Side P-FET R_{DSON}	$V_{INB13} = 3.8\text{ V}$, including bonding wire		87		$\text{m}\Omega$
	Low Side N-FET R_{DSON}	$V_{INB13} = 3.8\text{ V}$, including bonding wire		45		$\text{m}\Omega$
I_{LIM}	High side current limit	$V_{INB13} = 3.8\text{ V}$, each phase	4.0	4.5	5.0	A
	Low side current limit	$V_{INB13} = 3.8\text{ V}$, each phase	2.5	3.0	3.7	A
$t_{START}^{[1]}$	Startup time	EN rising to 90 % of output voltage		250	500	μs
$V_{RAMP}^{[1]}$	Output voltage slew rate	Programmable, RAMP[1:0] = 01b		12.5		$\text{mV}/\mu\text{s}$
$V_{soft_strup}^{[1]}$	Soft-start slew rate			12.5		$\text{mV}/\mu\text{s}$
POK	Output Power good		75	85	95	%
R_{Dis}	Output Active Discharge Resistance	One phase buck		100	150	Ω
$L^{[1]}$	Inductor value	Each phase		0.47		μH
$C_{OUT}^{[1]}$	Output capacitance	Minimum nominal capacitance	44			μF

[1] Guaranteed by design

13.5 BUCK2

Table 77. BUCK2

Unless otherwise specified, $V_{SYS} = 3.8\text{ V}$, $V_{INBx} = 3.8\text{ V}$, $V_{INL1} = 3.8\text{ V}$, $V_{BUCK2} = 0.85\text{ V}$, $C_{OUT} = 22\text{ }\mu\text{F}$, $T_{amb} = -40\text{ }^{\circ}\text{C} \sim +105\text{ }^{\circ}\text{C}$

Symbol	Parameter	Conditions	Min	Typ	Max	Unit
V_{INB26}	Input voltage range	INB26 pin	2.85		5.5	V
$I_{Shutdown}$	Shutdown current	Regulator disabled, $V_{INB26} = 5.0\text{ V}$		0.1		μA
I_Q	Quiescent current	Regulator enabled, No load, No switching		20		μA
I_{OUT_MAX}	Max Output Current		3000			mA
V_{BUCK2}	Programmable Output voltage range	I2C programmable, 12.5 mV step	0.6		2.1875	V
V_{BUCK2_OUT}	DC Output Voltage Accuracy	$V_{INB26} = 3.8\text{ V}$, $V_{BUCK2_OUT} = 0.85\text{ V}$, $I_{OUT} = 0\text{ A}$, FPWM mode, $25\text{ }^{\circ}\text{C}$	-0.6		+0.6	%
		$V_{INB26} = 3.8\text{ V}$, $V_{BUCK2_OUT} = 0.85\text{ V}$, $I_{OUT} = 0\text{ A}$, FPWM mode	-2		+2	%
$\Delta V_{OUT(\Delta V_{INB})}^{[1]}$	DC Line regulation	$V_{INB26} = 3\text{ V to }5\text{ V}$, $I_{OUT} = I_{OUT_MAX}$		2		mV/V
$\Delta V_{OUT(\Delta I_{OUT})}^{[1]}$	DC Load regulation	$0\text{ mA} < I_{OUT} < I_{OUT_MAX}$, $V_{BUCK2_OUT} = 0.85\text{ V}$		3		mV/A
$\Delta V_{OUT(\Delta I_{OUT})}^{[1]}$	Transient Load Response	I_{OUT} changes 0 to I_{OUT_MAX} (1 A/ μs slope), $V_{BUCK2_OUT} = 0.85\text{ V}$		50		mV
$\Delta V_{OUT}^{[1]}$	Output voltage Ripple	FPWM mode		10		mV
f_{sw}	Switching Frequency in CCM			2		MHz
R_{DSON}	High Side P-FET R_{DSON}	$V_{INB26} = 3.8\text{ V}$, including bonding wire		87		m Ω
	Low Side N-FET R_{DSON}	$V_{INB26} = 3.8\text{ V}$, including bonding wire		45		m Ω
I_{LIM}	High side current limit	$V_{INB26} = 3.8\text{ V}$	4.0	4.5	5.0	A
	Low side current limit	$V_{INB26} = 3.8\text{ V}$	2.5	3.0	3.7	A
$t_{START}^{[1]}$	Startup time	EN rising to 90 % of output voltage		250	500	μs
$V_{RAMP}^{[1]}$	Output voltage slew rate	Programmable, RAMP[1:0] = 01b		12.5		mV/ μs
$V_{soft_strup}^{[1]}$	Soft-start slew rate			12.5		mV/ μs
POK	Output Power good		75	85	95	%
R_{DIS}	Output Active Discharge Resistance			100	150	Ω
$L^{[1]}$	Inductor value			0.47		μH
$C_{OUT}^{[1]}$	Output capacitance	Minimum nominal capacitance	22			μF

[1] Guaranteed by design

13.6 BUCK3 (PCA9450AA)

Table 78. BUCK3 (PCA9450AA)

Unless otherwise specified, $V_{SYS} = 3.8\text{ V}$, $V_{INBx} = 3.8\text{ V}$, $V_{INL1} = 3.8\text{ V}$, $V_{BUCK3} = 0.85\text{ V}$, $C_{OUT} = 22\text{ }\mu\text{F}$, $T_{amb} = -40\text{ }^{\circ}\text{C} \sim +105\text{ }^{\circ}\text{C}$

Symbol	Parameter	Conditions	Min	Typ	Max	Unit
V_{INB13}	Input voltage range	INB13 pin	2.85		5.5	V
$I_{Shutdown}$	Shutdown current	Regulator disabled, $V_{INB13} = 5.0\text{ V}$		0.1		μA
I_Q	Quiescent current	Regulator enabled, No load, No switching		20		μA
I_{OUT_MAX}	Max Output Current		3000			mA
V_{BUCK3}	Programmable Output voltage range	I2C programmable, 12.5 mV step	0.6		2.1875	V
V_{BUCK3_OUT}	DC Output Voltage Accuracy	$V_{INB13} = 3.8\text{ V}$, $V_{BUCK3_OUT} = 0.85\text{ V}$, $I_{OUT} = 0\text{ A}$, FPWM mode, $25\text{ }^{\circ}\text{C}$	-0.6		+0.6	%
		$V_{INB13} = 3.8\text{ V}$, $V_{BUCK3_OUT} = 0.85\text{ V}$, $I_{OUT} = 0\text{ A}$, FPWM mode	-2		+2	%
$\Delta V_{OUT(\Delta V_{INB})}^{[1]}$	DC Line regulation	$V_{INB13} = 3\text{ V}$ to 5 V , $I_{OUT} = I_{OUT_MAX}$		2		mV/V
$\Delta V_{OUT(\Delta I_{OUT})}^{[1]}$	DC Load regulation	$0\text{ mA} < I_{OUT} < I_{OUT_MAX}$, $V_{BUCK3_OUT} = 0.85\text{ V}$		3		mV/A
$\Delta V_{OUT(\Delta I_{OUT})}^{[1]}$	Transient Load Response	I_{OUT} changes 0 to I_{OUT_MAX} (1 A/ μs slope), $V_{BUCK3_OUT} = 0.85\text{ V}$		50		mV
$\Delta V_{OUT}^{[1]}$	Output voltage Ripple	FPWM mode		10		mV
f_{sw}	Switching Frequency in CCM			2		MHz
R_{DSON}	High Side P-FET R_{DSON}	$V_{INB13} = 3.8\text{ V}$, including bonding wire		87		$\text{m}\Omega$
	Low Side N-FET R_{DSON}	$V_{INB13} = 3.8\text{ V}$, including bonding wire		45		$\text{m}\Omega$
I_{LIM}	High side current limit	$V_{INB13} = 3.8\text{ V}$	4.0	4.5	5.0	A
	Low side current limit	$V_{INB13} = 3.8\text{ V}$	2.5	3.0	3.7	A
$t_{START}^{[1]}$	Startup time	EN rising to 90 % of output voltage		250	500	μs
$V_{RAMP}^{[1]}$	Output voltage slew rate	Programmable, RAMP[1:0] = 01b		12.5		mV/ μs
$V_{soft_strup}^{[1]}$	Soft-start slew rate			12.5		mV/ μs
POK	Output Power good		75	85	95	%
R_{DIS}	Output Active Discharge Resistance			100	150	Ω
$L^{[1]}$	Inductor value			0.47		μH
$C_{OUT}^{[1]}$	Output capacitance	Minimum nominal capacitance	22			μF

[1] Guaranteed by design

13.7 BUCK4

Table 79. BUCK4

Unless otherwise specified, $V_{SYS} = 3.8\text{ V}$, $V_{INBx} = 3.8\text{ V}$, $V_{INL1} = 3.8\text{ V}$, $V_{BUCK4} = 3.3\text{ V}$, $C_{OUT} = 22\text{ }\mu\text{F}$, $T_{amb} = -40\text{ }^{\circ}\text{C} \sim +105\text{ }^{\circ}\text{C}$

Symbol	Parameter	Conditions	Min	Typ	Max	Unit
V_{INB45}	Input voltage range	INB45 pin	2.85		5.5	V
$I_{Shutdown}$	Shutdown current	Regulator disabled, $V_{INB45} = 5.0\text{ V}$		0.1		μA
I_Q	Quiescent current	Regulator enabled, No load, No switching		20		μA
I_{OUT_MAX}	Max Output Current		3000			mA
V_{BUCK4}	Programmable Output voltage range	I2C programmable, 25 mV step	0.6		3.4	V
V_{BUCK4_OUT}	DC Output Voltage Accuracy	$V_{INB45} = 3.8\text{ V}$, $V_{BUCK4_OUT} = 3.3\text{ V}$, $I_{OUT} = 0\text{ A}$, FPWM mode, $25\text{ }^{\circ}\text{C}$	-0.5		+0.5	%
		$V_{INB45} = 3.8\text{ V}$, $V_{BUCK4_OUT} = 3.3\text{ V}$, $I_{OUT} = 0\text{ A}$, FPWM mode	-2		+2	%
$\Delta V_{OUT(\Delta V_{INB})}^{[1]}$	DC Line regulation	$V_{INB45} = 4\text{ V to }5\text{ V}$, $I_{OUT} = I_{OUT_MAX}$		2		mV/V
$\Delta V_{OUT(\Delta I_{OUT})}^{[1]}$	DC Load regulation	$0\text{ mA} < I_{OUT} < I_{OUT_MAX}$, $V_{BUCK4_OUT} = 3.3\text{ V}$		6		mV/A
$\Delta V_{OUT(\Delta I_{OUT})}^{[1]}$	Transient Load Response	I_{OUT} changes 0 to I_{OUT_MAX} ($1\text{ A}/\mu\text{s}$ slope), $V_{BUCK4_OUT} = 3.3\text{ V}$		160		mV
$\Delta V_{OUT}^{[1]}$	Output voltage Ripple	FPWM mode		10		mV
f_{SW}	Switching Frequency in CCM			2		MHz
R_{DSON}	High Side P-FET R_{DSON}	$V_{INB45} = 3.8\text{ V}$, including bonding wire		87		$\text{m}\Omega$
	Low Side N-FET R_{DSON}	$V_{INB45} = 3.8\text{ V}$, including bonding wire		45		$\text{m}\Omega$
I_{LIM}	High side current limit	$V_{INB45} = 3.8\text{ V}$	4.0	4.5	5.0	A
	Low side current limit	$V_{INB45} = 3.8\text{ V}$	2.5	3.0	3.7	A
$t_{START}^{[1]}$	Startup time	EN rising to 90 % of output voltage		250	500	μs
$V_{soft_strup}^{[1]}$	Soft-start slew rate			12.5		$\text{mV}/\mu\text{s}$
POK	Output Power good		75	85	95	%
R_{DIS}	Output Active Discharge Resistance			100	150	Ω
$L^{[1]}$	Inductor value			0.47		μH
$C_{OUT}^{[1]}$	Output capacitance	Minimum nominal capacitance	22			μF

[1] Guaranteed by design

13.8 BUCK5

Table 80. BUCK5

Unless otherwise specified, $V_{SYS} = 3.8\text{ V}$, $V_{INBx} = 3.8\text{ V}$, $V_{INL1} = 3.8\text{ V}$, $V_{BUCK5} = 1.8\text{ V}$, $C_{OUT} = 22\text{ }\mu\text{F}$, $T_{amb} = -40\text{ }^{\circ}\text{C} \sim +105\text{ }^{\circ}\text{C}$

Symbol	Parameter	Conditions	Min	Typ	Max	Unit
V_{INB45}	Input voltage range	INB45 pin	2.85		5.5	V
$I_{Shutdown}$	Shutdown current	Regulator disabled, $V_{INB45} = 5.0\text{ V}$		0.1		μA
I_Q	Quiescent current	Regulator enabled, No load, No switching		20		μA
I_{OUT_MAX}	Max Output Current		2000			mA
V_{BUCK5}	Programmable Output voltage range	I2C programmable, 25 mV step	0.6		3.4	V
V_{BUCK5_OUT}	DC Output Voltage Accuracy	$V_{INB45} = 3.8\text{ V}$, $V_{BUCK5_OUT} = 1.8\text{ V}$, $I_{OUT} = 0\text{ A}$, FPWM mode, $25\text{ }^{\circ}\text{C}$	-0.5		+0.5	%
		$V_{INB45} = 3.8\text{ V}$, $V_{BUCK5_OUT} = 1.8\text{ V}$, $I_{OUT} = 0\text{ A}$, FPWM mode	-2		+2	%
$\Delta V_{OUT(\Delta V_{INB})}^{[1]}$	DC Line regulation	$V_{INB45} = 3\text{ V to }5\text{ V}$, $I_{OUT} = I_{OUT_MAX}$		2		mV/V
$\Delta V_{OUT(\Delta I_{OUT})}^{[1]}$	DC Load regulation	$0\text{ mA} < I_{OUT} < I_{OUT_MAX}$, $V_{BUCK5_OUT} = 1.8\text{ V}$		7		mV/A
$\Delta V_{OUT(\Delta I_{OUT})}^{[1]}$	Transient Load Response	I_{OUT} changes 0 to I_{OUT_MAX} (1 A/ μs slope), $V_{BUCK5_OUT} = 1.8\text{ V}$		50		mV
$\Delta V_{OUT}^{[1]}$	Output voltage Ripple	FPWM mode		22		mV
f_{sw}	Switching Frequency in CCM			2		MHz
R_{DSON}	High Side P-FET R_{DSON}	$V_{INB45} = 3.8\text{ V}$, including bonding wire		130		m Ω
	Low Side N-FET R_{DSON}	$V_{INB45} = 3.8\text{ V}$, including bonding wire		70		m Ω
I_{LIM}	High side current limit	$V_{INB45} = 3.8\text{ V}$	3.0	3.5	4.0	A
	Low side current limit	$V_{INB45} = 3.8\text{ V}$	1.5	2	2.7	A
$t_{START}^{[1]}$	Startup time	EN rising to 90 % of output voltage		250	500	μs
$V_{soft_strup}^{[1]}$	Soft-start slew rate			12.5		mV/ μs
POK	Output Power good		75	85	95	%
R_{DIS}	Output Active Discharge Resistance			100	150	Ω
$L^{[1]}$	Inductor value			0.47		μH
$C_{OUT}^{[1]}$	Output capacitance	Minimum nominal capacitance	22			μF

[1] Guaranteed by design

13.9 BUCK6

Table 81. BUCK6

Unless otherwise specified, $V_{SYS} = 3.8\text{ V}$, $V_{INBx} = 3.8\text{ V}$, $V_{INL1} = 3.8\text{ V}$, $V_{BUCK6} = 1.1\text{ V}$, $C_{OUT} = 22\text{ }\mu\text{F}$, $T_{amb} = -40\text{ }^{\circ}\text{C}$ to $+105\text{ }^{\circ}\text{C}$

Symbol	Parameter	Conditions	Min	Typ	Max	Unit
V_{INB26}	Input voltage range	INB26 pin	2.85		5.5	V
$I_{Shutdown}$	Shutdown current	Regulator disabled, $V_{INB26} = 5.0\text{ V}$		0.1		μA
I_Q	Quiescent current	Regulator enabled, No load, No switching		20		μA
I_{OUT_MAX}	Max Output Current		2000			mA
V_{BUCK6}	Programmable Output voltage range	I2C programmable, 25 mV step	0.6		3.4	V
V_{BUCK6_OUT}	DC Output Voltage Accuracy	$V_{INB26} = 3.8\text{ V}$, $V_{BUCK6_OUT} = 1.1\text{ V}$, $I_{OUT} = 0\text{ A}$, FPWM mode, $25\text{ }^{\circ}\text{C}$	-0.8		+0.8	%
		$V_{INB26} = 3.8\text{ V}$, $V_{BUCK6_OUT} = 1.1\text{ V}$, $I_{OUT} = 0\text{ A}$, FPWM mode	-2		+2	%
$\Delta V_{OUT(\Delta V_{INB})}^{[1]}$	DC Line regulation	$V_{INB26} = 3\text{ V}$ to 5 V , $I_{OUT} = I_{OUT_MAX}$		2		mV/V
$\Delta V_{OUT(\Delta I_{OUT})}^{[1]}$	DC Load regulation	$0\text{ mA} < I_{OUT} < I_{OUT_MAX}$, $V_{BUCK6_OUT} = 1.1\text{ V}$		6		mV/A
$\Delta V_{OUT(\Delta I_{OUT})}^{[1]}$	Transient Load Response	I_{OUT} changes 0 to I_{OUT_MAX} (1 A/ μs slope), $V_{BUCK6_OUT} = 1.1\text{ V}$		50		mV
$\Delta V_{OUT}^{[1]}$	Output voltage Ripple	FPWM mode		18		mV
f_{SW}	Switching Frequency in CCM			2		MHz
R_{DSON}	High Side P-FET R_{DSON}	$V_{INB26} = 3.8\text{ V}$, including bonding wire		130		$\text{m}\Omega$
	Low Side N-FET R_{DSON}	$V_{INB26} = 3.8\text{ V}$, including bonding wire		70		$\text{m}\Omega$
I_{LIM}	High side current limit	$V_{INB26} = 3.8\text{ V}$	3.0	3.5	4.0	A
	Low side current limit	$V_{INB26} = 3.8\text{ V}$	1.5	2	2.7	A
$t_{START}^{[1]}$	Startup time	EN rising to 90 % of output voltage		250	500	μs
$V_{soft_strup}^{[1]}$	Soft-start slew rate			12.5		$\text{mV}/\mu\text{s}$
POK	Output Power good		75	85	95	%
R_{DIS}	Output Active Discharge Resistance			100	150	Ω
$L^{[1]}$	Inductor value			0.47		μH
$C_{OUT}^{[1]}$	Output capacitance	Minimum nominal capacitance	22			μF

[1] Guaranteed by design

13.10 LDO1

Table 82. LDO1

Unless otherwise specified, $V_{SYS} = 3.8\text{ V}$, $V_{INBx} = 3.8\text{ V}$, $V_{INL1} = 3.8\text{ V}$, $V_{LDO1} = 1.8\text{ V}$, $C_{INL1} = 4.7\text{ }\mu\text{F}$, $C_{OUT} = 1\text{ }\mu\text{F}$, $T_{amb} = -40\text{ }^{\circ}\text{C} \sim +105\text{ }^{\circ}\text{C}$

Symbol	Parameter	Conditions	Min	Typ	Max	Unit
V_{IN}	Input voltage range	INL1 pin	2.85		5.5	V
I_Q	Quiescent current	Regulator enabled, No load		2		μA
I_{OUT_MAX}	Maximum Output DC Current	$V_{IN} > 2.85\text{ V}$, $V_{LDO1} = 1.8\text{ V}$	10			mA
I_{LIMIT}	Short Current Limit	Output shorted to GND	30		60	mA
V_{DO}	Dropout Voltage	$I_{OUT} = I_{OUT_MAX}$, $V_{IN} = 3.2\text{ V}$, $L1_OUT[2:0] = 0x7$, 3.3 V		35	60	mV
V_{LDO1}	Nominal output voltage	I ² C Programmable, 100 mV step	1.6		3.3	V
	Default voltage			1.8		V
	DC accuracy	$V_{LDO1} = 1.8\text{ V}$, $I_{Load} = 5\text{ mA}$	-3		3	%
$V_{NOISE}^{[1]}$	Output noise	$f = 10\text{ Hz to }10\text{ kHz}$, $I_{OUT} = 10\%$ of I_{MAX} , $V_{LDO1} = 1.8\text{ V}$		400		μV
$\Delta V_{OUT(\Delta VINL)}$	DC Line regulation	$V_{LDO1} + 0.3\text{ V} < V_{IN} < 5.5\text{ V}$, $I_{OUT(LDO1)} = 10\%$ of I_{OUT_MAX}		0.2	0.5	%/V
$\Delta V_{OUT(\Delta IOUT)}$	DC Load regulation	$V_{IN} = V_{LDO1} + 0.3\text{ V to }5.5\text{ V}$, $0\text{ mA} < I_{OUT} < I_{OUT_MAX}$		0.5	1	%
$\Delta V_{OUT(\Delta VINL)}^{[1]}$	Transient Line Response	$V_{LDO1} + 0.3\text{ V} < V_{IN} < 5.5\text{ V}$, $I_{OUT(LDO1)} = 10\%$ of I_{OUT_MAX} , $t_r = 10\text{ }\mu\text{s}$		0.5		%/V
$\Delta V_{OUT(\Delta IOUT)}^{[1]}$	Transient Load Response	$V_{IN} = V_{LDO1} + 0.3\text{ V to }5.5\text{ V}$, $1\text{ mA} < I_{OUT} < I_{OUT_MAX}$, $t_r = 10\text{ }\mu\text{s}$, $V_{LDO1} = 1.8\text{ V}$	-3		3	%
$PSRR^{[1]}$	Power Supply Rejection ratio	$f = 10\text{ Hz to }10\text{ kHz}$, $I_{OUT} = 10\%$ of I_{OUT_MAX}		45		dB
$V_{soft_strup}^{[1]}$	Soft-start slew rate	$I_{OUT} = 0\text{ mA}$, 10 % to 90 % of V_{LDO1}		15		mV/ μs
$V_{ov_srtp}^{[1]}$	Overshoot at startup	$I_{OUT} = 0\text{ mA}$			10	mV
$t_{EN}^{[1]}$	Enable time	EN rising to 90 % of output voltage		150		μs
POK	Output Power good	Percentage of V_{LDO1} configuration	75	85	92	%
R_{DIS}	Active Discharge Resistance			100	150	Ω
$C_{OUT}^{[1]}$	Output capacitance	Minimum nominal capacitance	1			μF

[1] Guaranteed by design

13.11 LDO2

Table 83. LDO2

Unless otherwise specified, $V_{SYS} = 3.8\text{ V}$, $V_{INBx} = 3.8\text{ V}$, $V_{INL1} = 3.8\text{ V}$, $V_{LDO2} = 0.85\text{ V}$, $C_{INL1} = 4.7\text{ }\mu\text{F}$, $C_{OUT} = 1\text{ }\mu\text{F}$, $T_{amb} = -40\text{ }^{\circ}\text{C} \sim +105\text{ }^{\circ}\text{C}$

Symbol	Parameter	Conditions	Min	Typ	Max	Unit
V_{IN}	Input voltage range	INL1 pin	2.85		5.5	V
I_Q	Quiescent current	Regulator enabled, No load		2		μA
I_{OUT_MAX}	Maximum Output DC Current	$V_{IN} > 2.8\text{ V}$, $V_{LDO2} = 0.8\text{ V}$	10			mA
I_{LIMIT}	Short Current Limit	Output shorted to GND	30		60	mA
V_{DO}	Dropout Voltage	$I_{OUT} = I_{OUT_MAX}$		35	60	mV
V_{LDO2}	Nominal output voltage	I ² C Programmable, 50 mV step	0.8		1.5	V
	Default voltage			0.85		V
	DC accuracy	$V_{LDO2} = 0.8\text{ V}$, $I_{Load} = 5\text{ mA}$	-3		3	%
$V_{NOISE}^{[1]}$	Output noise	$f = 10\text{ Hz to }10\text{ kHz}$, $I_{OUT} = 10\%$ of I_{MAX} , $V_{LDO2} = 0.8\text{ V}$		400		μV
$\Delta V_{OUT(\Delta VINL)}$	DC Line regulation	$V_{LDO2} + 0.3\text{ V} < V_{IN} < 5.5\text{ V}$, $I_{OUT(LDO2)} = 10\%$ of I_{OUT_MAX}		0.2	0.5	%/V
$\Delta V_{OUT(\Delta IOUT)}$	DC Load regulation	$V_{IN} = V_{LDO2} + 0.3\text{ V to }5.5\text{ V}$, $0\text{ mA} < I_{OUT} < I_{OUT_MAX}$		0.5	1	%
$\Delta V_{OUT(\Delta VINL)}^{[1]}$	Transient Line Response	$V_{LDO2} + 0.3\text{ V} < V_{IN} < 5.5\text{ V}$, $I_{OUT(LDO2)} = 10\%$ of I_{OUT_MAX} , $t_r = 10\text{ }\mu\text{s}$		0.5		%/V
$\Delta V_{OUT(\Delta IOUT)}^{[1]}$	Transient Load Response	$V_{IN} = V_{OUT} + 0.3\text{ V to }5.5\text{ V}$, $1\text{ mA} < I_{OUT} < I_{OUT_MAX}$, $t_r = 10\text{ }\mu\text{s}$, $V_{LDO2} = 0.8\text{ V}$	-3		3	%
PSRR ^[1]	Power Supply Rejection ratio	$f = 10\text{ Hz to }10\text{ kHz}$, $I_{OUT} = 10\%$ of I_{OUT_MAX}		60		dB
$V_{soft_strup}^{[1]}$	Soft-start slew rate	$I_{OUT} = 0\text{ mA}$, 10 % to 90 % of V_{LDO2}		15		mV/ μs
$V_{ov_srtup}^{[1]}$	Overshoot at startup	$I_{OUT} = 0\text{ mA}$			10	mV
$t_{EN}^{[1]}$	Enable time	EN rising to 90 % of output voltage		100		μs
POK	Output Power good	Percentage of V_{LDO2} configuration	75	85	92	%
R_{Dis}	Active Discharge Resistance			100	150	Ω
$C_{OUT}^{[1]}$	Output capacitance	Minimum nominal capacitance	1			μF

[1] Guaranteed by design

13.12 LDO3

Table 84. LDO3

Unless otherwise specified, $V_{SYS} = 3.8\text{ V}$, $V_{INBx} = 3.8\text{ V}$, $V_{INL1} = 3.8\text{ V}$, $V_{LDO3} = 1.8\text{ V}$, $C_{INL1} = 4.7\text{ }\mu\text{F}$, $C_{OUT} = 2.2\text{ }\mu\text{F}$, $T_{amb} = -40\text{ }^{\circ}\text{C} \sim +105\text{ }^{\circ}\text{C}$

Symbol	Parameter	Conditions	Min	Typ	Max	Unit
V_{IN}	Input voltage range	INL1	2.85		5.5	V
$I_{Shutdown}$	Shutdown current	Regulator disabled, $V_{IN} = 5.0\text{ V}$		0.1		μA
I_Q	Quiescent current	Regulator enabled, No load		15		μA
I_{OUT_MAX}	Maximum Output DC Current	$V_{IN} > 2.8\text{ V}$, $V_{LDO3} = 1.8\text{ V}$	300			mA
I_{LIMIT}	Short Current Limit	Output shorted to GND	310		480	mA
V_{DO}	Dropout Voltage	$I_{OUT} = I_{OUT_MAX}$, $V_{IN} = 3.2\text{ V}$, $L3_OUT[4:0] = 0x1F$, 3.3 V		70	100	mV
V_{LDO3}	Nominal output voltage	I ² C Programmable, 100 mV step	0.8		3.3	V
	Default voltage			1.8		V
	DC accuracy	$V_{LDO3} = 1.8\text{ V}$, $I_{Load} = 5\text{ mA}$	-3		3	%
V_{NOISE}	Output noise	$f = 10\text{ Hz to }10\text{ kHz}$, $I_{OUT} = 10\%$ of I_{MAX} , $V_{LDO3} = 1.8\text{ V}$		150		μV
$\Delta V_{OUT(\Delta VINL)}$	DC Line regulation	$V_{LDO3} + 0.3\text{ V} < V_{IN} < 5.5\text{ V}$, $I_{OUT(LDO3)} = 10\%$ of I_{OUT_MAX}		0.2	0.5	%/V
$\Delta V_{OUT(\Delta IOUT)}$	DC Load regulation	$V_{IN} = V_{LDO3} + 0.3\text{ V to }5.5\text{ V}$, $0\text{ mA} < I_{OUT} < I_{OUT_MAX}$		0.6		%
$\Delta V_{OUT(\Delta VINL)}^{[1]}$	Transient Line Response	$V_{LDO3} + 0.3\text{ V} < V_{IN} < 5.5\text{ V}$, $I_{OUT(LDO3)} = 10\%$ of I_{OUT_MAX} , $t_r = 10\text{ }\mu\text{s}$		0.5		%/V
$\Delta V_{OUT(\Delta IOUT)}^{[1]}$	Transient Load Response	$V_{IN} = V_{LDO3} + 0.3\text{ V to }5.5\text{ V}$, $1\text{ mA} < I_{OUT} < I_{OUT_MAX}$, $t_r = 10\text{ }\mu\text{s}$, $V_{LDO3} = 1.8\text{ V}$, $T_{amb} = 25\text{ }^{\circ}\text{C}$	-3		3	%
$PSRR^{[1]}$	Power Supply Rejection ratio	$f = 10\text{ Hz to }10\text{ kHz}$, $I_{OUT} = 10\%$ of I_{OUT_MAX}		55		dB
$V_{soft_strup}^{[1]}$	Soft-start slew rate	$I_{OUT} = 0\text{ mA}$, 10 % to 90 % of V_{LDO3}		15		mV/ μs
$V_{ov_srtup}^{[1]}$	Overshoot at startup	$I_{OUT} = 0\text{ mA}$			10	mV
$t_{EN}^{[1]}$	Enable time	EN rising to 90 % of output voltage		150		μs
POK	Output Power good	Percentage of V_{LDO3} configuration	75	85	92	%
R_{DIS}	Active Discharge Resistance			100	150	Ω
$C_{OUT}^{[1]}$	Output capacitance	Minimum nominal capacitance	2.2			μF

[1] Guaranteed by design

13.13 LDO4

Table 85. LDO4

Unless otherwise specified, $V_{SYS} = 3.8\text{ V}$, $V_{INBx} = 3.8\text{ V}$, $V_{INL1} = 3.8\text{ V}$, $V_{LDO4} = 0.9\text{ V}$, $C_{INL1} = 4.7\text{ }\mu\text{F}$, $C_{OUT} = 1\text{ }\mu\text{F}$, $T_{amb} = -40\text{ }^{\circ}\text{C} \sim +105\text{ }^{\circ}\text{C}$

Symbol	Parameter	Conditions	Min	Typ	Max	Unit
V_{IN}	Input voltage range	INL1	2.85		5.5	V
$I_{Shutdown}$	Shutdown current	Regulator disabled, $V_{IN} = 5.0\text{ V}$		0.1		μA
I_Q	Quiescent current	Regulator enabled, No load		15		μA
I_{OUT_MAX}	Maximum Output DC Current	$V_{IN} > 2.8$, $V_{LDO4} = 0.9\text{ V}$	200			mA
I_{LIMIT}	Short Current Limit	Output shorted to GND	210		330	mA
V_{DO}	Dropout Voltage	$I_{OUT} = I_{OUT_MAX}$, $V_{IN} = 3.2\text{ V}$, $L4_OUT[4:0] = 0x1F$, 3.3 V		60	100	mV
V_{LDO4}	Nominal output voltage	I^2C Programmable, 100 mV step	0.8		3.3	V
	Default voltage			0.9		V
	DC accuracy	$V_{LDO4} = 0.9\text{ V}$, $I_{Load} = 5\text{ mA}$	-3		3	%
V_{NOISE}	Output noise	$f = 10\text{ Hz to }10\text{ kHz}$, $I_{OUT} = 10\%$ of I_{MAX} , $V_{LDO4} = 0.9\text{ V}$		150		μV
$\Delta V_{OUT(\Delta VINL)}$	DC Line regulation	$V_{LDO4} + 0.3\text{ V} < V_{IN} < 5.5\text{ V}$, $I_{OUT(LDO4)} = 10\%$ of I_{OUT_MAX}		0.2	0.5	%/V
$\Delta V_{OUT(\Delta IOUT)}$	DC Load regulation	$V_{IN} = V_{LDO4} + 0.3\text{ V to }5.5\text{ V}$, $0\text{ mA} < I_{OUT} < I_{OUT_MAX}$		0.9		%
$\Delta V_{OUT(\Delta VINL)}^{[1]}$	Transient Line Response	$V_{LDO4} + 0.3\text{ V} < V_{IN} < 5.5\text{ V}$, $I_{OUT(LDO4)} = 10\%$ of I_{OUT_MAX} , $t_r = 10\text{ }\mu\text{s}$		0.5		%/V
$\Delta V_{OUT(\Delta IOUT)}^{[1]}$	Transient Load Response	$V_{IN} = V_{LDO4} + 0.3\text{ V to }5.5\text{ V}$, $1\text{ mA} < I_{OUT} < I_{OUT_MAX}$, $t_r = 10\text{ }\mu\text{s}$, $V_{LDO4} = 0.9\text{ V}$, $T_{amb} = 25\text{ }^{\circ}\text{C}$	-4		4	%
$PSRR^{[1]}$	Power Supply Rejection ratio	$f = 10\text{ Hz to }10\text{ kHz}$, $I_{OUT} = 10\%$ of I_{OUT_MAX}		60		dB
$V_{soft_strup}^{[1]}$	Soft-start slew rate	$I_{OUT} = 0\text{ mA}$, 10% to 90% of V_{LDO4}		20		mV/ μs
$V_{ov_srtup}^{[1]}$	Overshoot at startup	$I_{OUT} = 0\text{ mA}$			10	mV
$t_{EN}^{[1]}$	Enable time	EN rising to 90% of output voltage		100		μs
POK	Output Power good	Percentage of V_{LDO4} configuration	75	85	92	%
R_{DIS}	Active Discharge Resistance			100	150	Ω
$C_{OUT}^{[1]}$	Output capacitance	Minimum nominal capacitance	1			μF

[1] Guaranteed by design

13.14 LDO5

Table 86. LDO5

Unless otherwise specified, $V_{SYS} = 3.8\text{ V}$, $V_{INBx} = 3.8\text{ V}$, $V_{INL1} = 3.8\text{ V}$, $V_{LDO5} = 3.3\text{ V}$, $C_{INL1} = 4.7\text{ }\mu\text{F}$, $C_{OUT} = 1\text{ }\mu\text{F}$, $T_{amb} = -40\text{ }^{\circ}\text{C} \sim +105\text{ }^{\circ}\text{C}$

Symbol	Parameter	Conditions	Min	Typ	Max	Unit
V_{IN}	Input voltage range	INL1 pin	2.85		5.5	V
		INL1 pin, when $V_{LDO5} = 3.3\text{ V}$	$V_{LDO5} + V_{DO}$		5.5	V
$I_{Shutdown}$	Shutdown current	Regulator disabled, $V_{IN} = 5.0\text{ V}$		0.1		μA
I_Q	Quiescent current	Regulator enabled, No load		15		μA
I_{OUT_MAX}	Maximum Output DC Current	$V_{IN} > V_{LDO5} + V_{DO(MAX)}$, $V_{LDO5} = 3.3\text{ V}$	150			mA
I_{LIMIT}	Short Current Limit	Output shorted to GND	160		280	mA
V_{DO}	Dropout Voltage	$I_{OUT} = I_{OUT_MAX}$, $V_{IN} = 3.2\text{ V}$, $L5_OUT_L[3:0] = 0xF$, 3.3 V		50	100	mV
V_{LDO5}	Nominal output voltage	I ² C Programmable, 100 mV step	1.8		3.3	V
	Default voltage	SD_VSEL = Low		3.3		V
		SD_VSEL = High		1.8		V
DC accuracy	$V_{LDO5} = 1.8\text{ V}$, $I_{Load} = 5\text{ mA}$	-3		3	%	
V_{NOISE}	Output noise	$f = 10\text{ Hz to }10\text{ kHz}$, $I_{OUT} = 10\%$ of I_{MAX} , $V_{LDO5} = 3.3\text{ V}$		300		μV
$\Delta V_{OUT(\Delta VINL)}$	DC Line regulation	$V_{LDO5} + 0.3\text{ V} < V_{IN} < 5.5\text{ V}$, $I_{OUT(LDO5)} = 10\%$ of I_{OUT_MAX}		0.2	0.5	%/V
$\Delta V_{OUT(\Delta IOUT)}$	DC Load regulation	$V_{IN} = V_{LDO5} + 0.3\text{ V to }5.5\text{ V}$, $0\text{ mA} < I_{OUT} < I_{OUT_MAX}$		0.3		%
$\Delta V_{OUT(\Delta VINL)}^{[1]}$	Transient Line Response	$V_{LDO5} + 0.3\text{ V} < V_{IN} < 5.5\text{ V}$, $I_{OUT(LDO5)} = 10\%$ of I_{OUT_MAX}		0.5		%/V
$\Delta V_{OUT(\Delta IOUT)}^{[1]}$	Transient Load Response	$V_{IN} = V_{LDO5} + 0.3\text{ V to }5.5\text{ V}$, $1\text{ mA} < I_{OUT} < I_{OUT_MAX}$, $t_r = 10\text{ }\mu\text{s}$, $V_{LDO5} = 3.3\text{ V}$, $T_{amb} = 25\text{ }^{\circ}\text{C}$	-3		3	%
PSRR ^[1]	Power Supply Rejection ratio	$f = 10\text{ Hz to }10\text{ kHz}$, $I_{OUT} = 10\%$ of I_{OUT_MAX}		50		dB
$V_{soft_strup}^{[1]}$	Soft-start slew rate	$I_{OUT} = 0\text{ mA}$, 10 % to 90 % of V_{LDO5}		15		mV/ μs
$V_{ov_srtup}^{[1]}$	Overshoot at startup	$I_{OUT} = 0\text{ mA}$			10	mV
$t_{EN}^{[1]}$	Enable time	EN rising to 90 % of output voltage		200		μs
POK	Output Power good	Percentage of V_{LDO5} configuration	75	85	92	%
R_{DIS}	Active Discharge Resistance			100	150	Ω
$C_{OUT}^{[1]}$	Output capacitance	Minimum nominal capacitance	1			μF

[1] Guaranteed by design

13.15 Load SW

Table 87. Load SW

Unless otherwise specified, $V_{SYS} = 3.8\text{ V}$, $V_{INBx} = 3.8\text{ V}$, $V_{INL1} = 3.8\text{ V}$, $V_{SWIN} = 3.8\text{ V}$, $C_{SWIN} = C_{SWOUT} = 1\text{ }\mu\text{F}$, $T_{amb} = -40\text{ }^{\circ}\text{C}$ ~ $+105\text{ }^{\circ}\text{C}$

Symbol	Parameter	Conditions	Min	Typ	Max	Unit
V_{SWIN}	Input voltage range	SWIN	2.8		5.5	V
I_Q	Quiescent current	Switch enabled, No load, $V_{SWIN} = 3.3\text{ V}$		5	8	μA
I_{SHDN}	Shut down current	$SWEN = 0\text{ V}$, $V_{SWIN} = 3.3\text{ V}$		1	2.5	μA
$I_{OC}^{[1]}$	OverCurrent Threshold		450	800		mA
$I_{SC}^{[1]}$	Short circuit current threshold			2		A
R_{DSON}	Switch ON resistance	$V_{SWIN} = 3.3\text{ V}$, $I_{LOAD} = 200\text{ mA}$, including bonding wire resistance		150	210	m Ω
$t_{EN}^{[1]}$	Enable time	Time to SWOUT 10 % from EN pin high, $V_{SWIN} = 3.3\text{ V}$		90	120	μs
$t_{ON}^{[1]}$	Output rise time	$CL = 10\text{ }\mu\text{F}$, $V_{SWIN} = 3.3\text{ V}$, SWOUT 10 % to 90 %		200	500	μs
R_{DIS}	Active Discharge Resistance	$SWEN = 0\text{ V}$		80	120	Ω

[1] Guaranteed by design

13.16 32 kHz Xtal driver

Table 88. 32 kHz Xtal driver

Unless otherwise specified, $V_{SYS} = 3.8\text{ V}$, $V_{INBx} = 3.8\text{ V}$, $V_{INL1} = 3.8$, $T_{amb} = -40\text{ °C} \sim +105\text{ °C}$

Symbol	Parameter	Conditions	Min	Typ	Max	Unit
f_{OSC_32K}	Clock frequency	Internal Oscillator	29	32.77	36	kHz
$f_{CLK}^{[1]}$	Clock frequency	External 32.768 kHz crystal oscillator		32.768		kHz
$t_{RTCSTB}^{[1]}$	Oscillator stabilization time			1000		ms
Duty ^[1]	Output Duty cycle	External 32.768 kHz crystal oscillator	30	50	70	%
V_{OL}	Output Low level	$I_{OL} = 1\text{ mA}$			0.4	V
V_{OH}	Output High level	$V_{LDO1} = 1.8\text{ V}$, $I_{OL} = 1\text{ mA}$	1.6			V

[1] Guaranteed by design

13.17 I²C-bus interface and logic I/OTable 89. I²C-bus interface and logic I/O

Unless otherwise specified, VSYS = 3.8 V, VINBx = 3.8 V, VINL1 = 3.8, Tamb = -40 °C ~ +105 °C

Symbol	Parameter	Conditions	Min	Typ	Max	Unit
SCL, SDA						
f _{I2C}	I ² C Clock frequency		-	-	1	MHz
V _{IH}	High-level Input voltage	SCL, SDA; VSYS= 3.0 V to 5.5 V	1.2	-	-	V
V _{IL}	Low-level Input voltage	SCL, SDA; VSYS= 3.0 V to 5.5 V	-	-	0.4	V
V _{hys}	Hysteresis of Schmitt trigger inputs		0.01	-	-	V
VOL	Low-level output voltage	SDA, Iload = 20 mA, VSYS = 3.0 V to 5.5 V	0	-	0.4	V
t _{HD,STA} ^[1]	Hold time (repeated) START condition	Fast mode plus; After this period, the first clock pulse is generated	0.26	-	-	μs
t _{LOW} ^[1]	LOW period of I2C clock	Fast mode plus	0.5	-	-	μs
t _{HIGH} ^[1]	HIGH period of I2C clock	Fast mode plus	0.26	-	-	μs
t _{SU,STA} ^[1]	Setup time (repeated) START condition	Fast mode plus	0.26	-	-	μs
t _{HD,DAT} ^[1]	Data Hold time	Fast mode plus	0	-	-	μs
t _{SU,DAT} ^[1]	Data Setup time	Fast mode plus	50	-	-	ns
t _r ^[1]	Rise time of I2C_SCL and I2C_SDA signals	Fast mode plus	-	-	120	ns
t _f ^[1]	Fall time of I2C_SCL and I2C_SDA signals	Fast mode plus	-	-	120	ns
t _{SU,STO} ^[1]	Setup time for STOP condition	Fast mode plus	0.26	-	-	μs
t _{BUF} ^[1]	Bus free time between STOP and START condition	Fast mode plus	0.5	-	-	μs
t _{VD,DAT} ^[1]	Data valid time	Fast mode plus		-	0.45	μs
t _{VD,ACK} ^[1]	Data valid acknowledge time	Fast mode plus		-	0.45	μs
t _{SP} ^[1]	Pulse width of spikes that must be suppressed by input filter		0	-	50	ns

[1] Guaranteed by design

14 Package outline

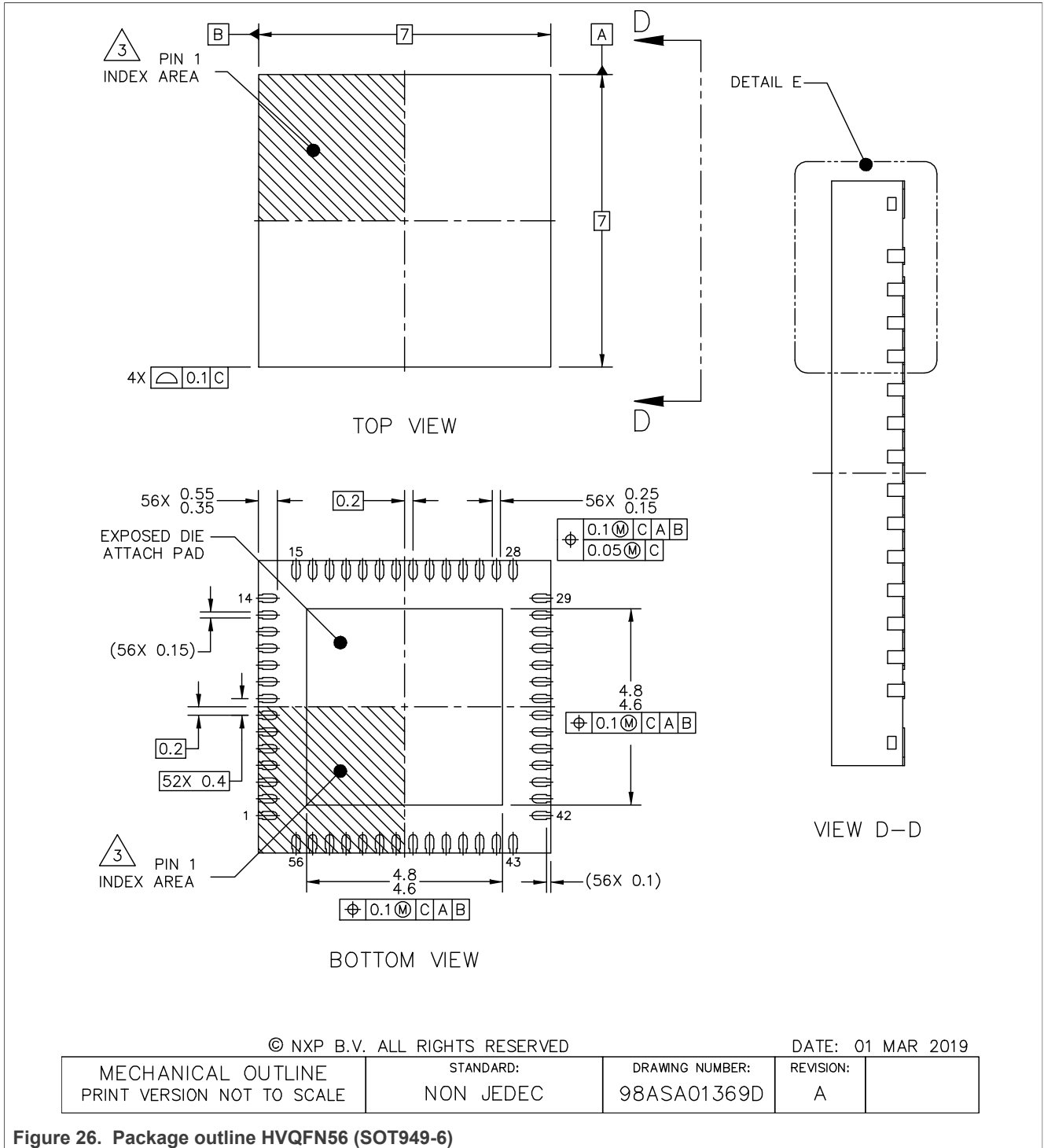

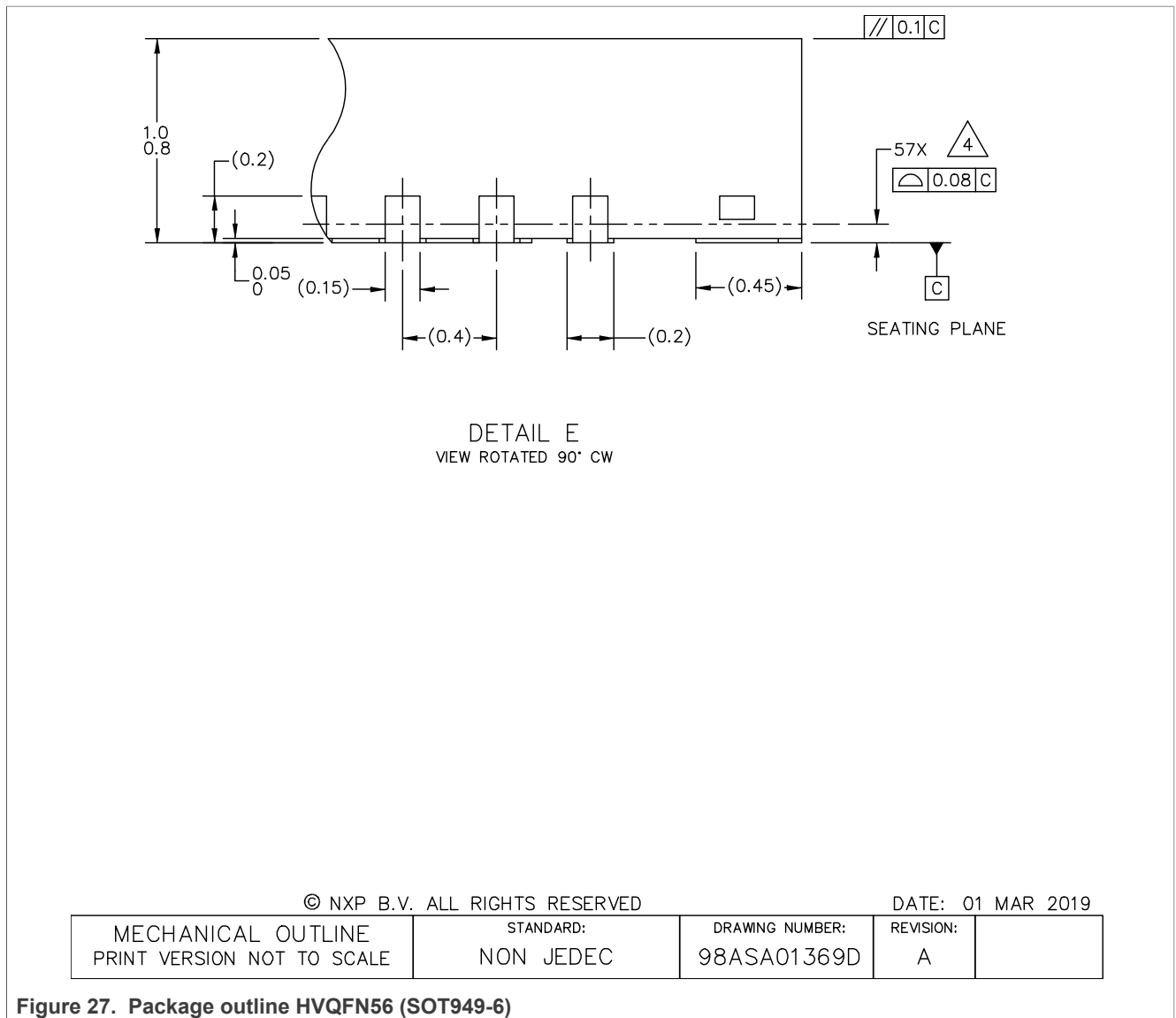
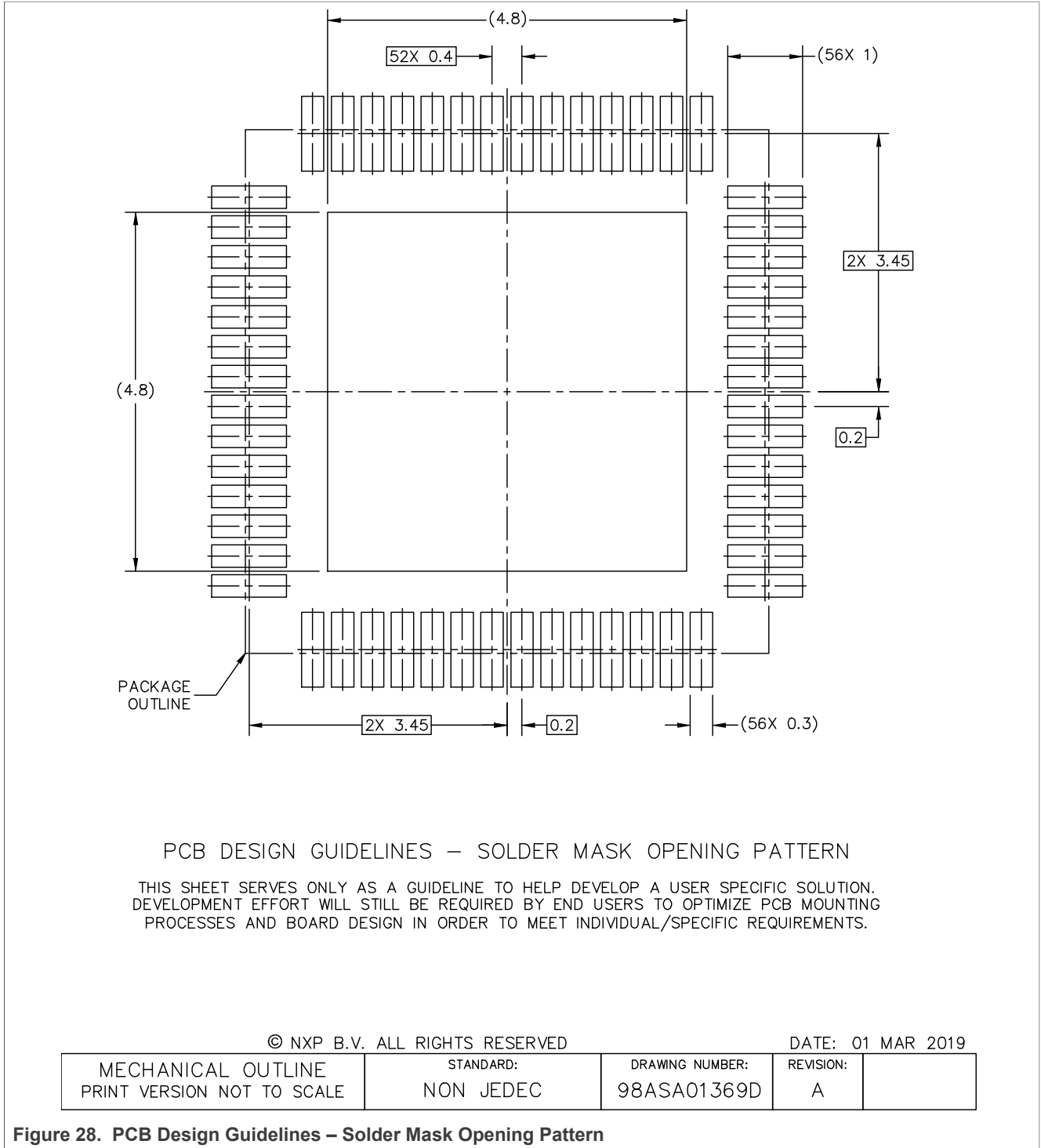
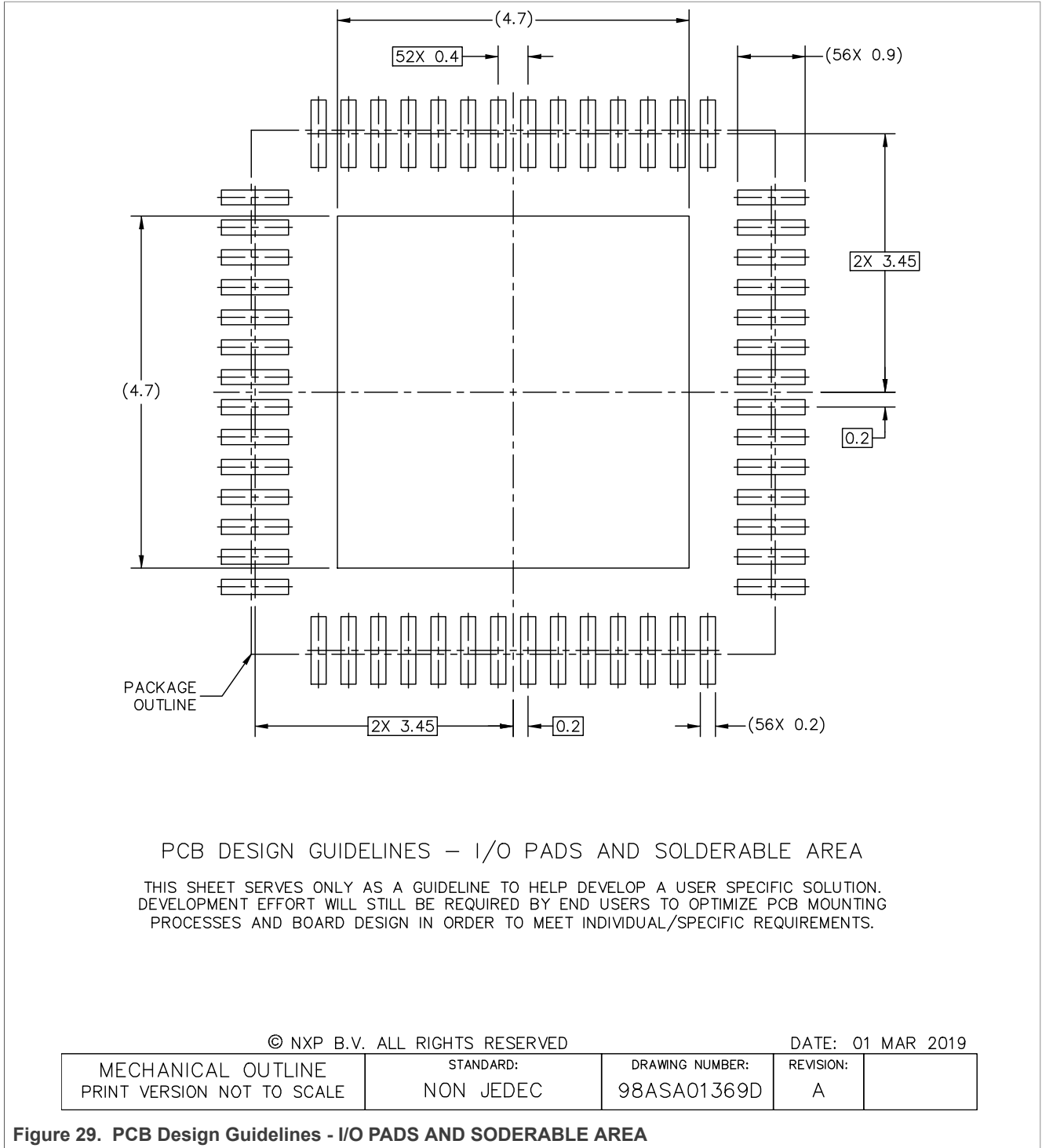

Figure 27. Package outline HVQFN56 (SOT949-6)





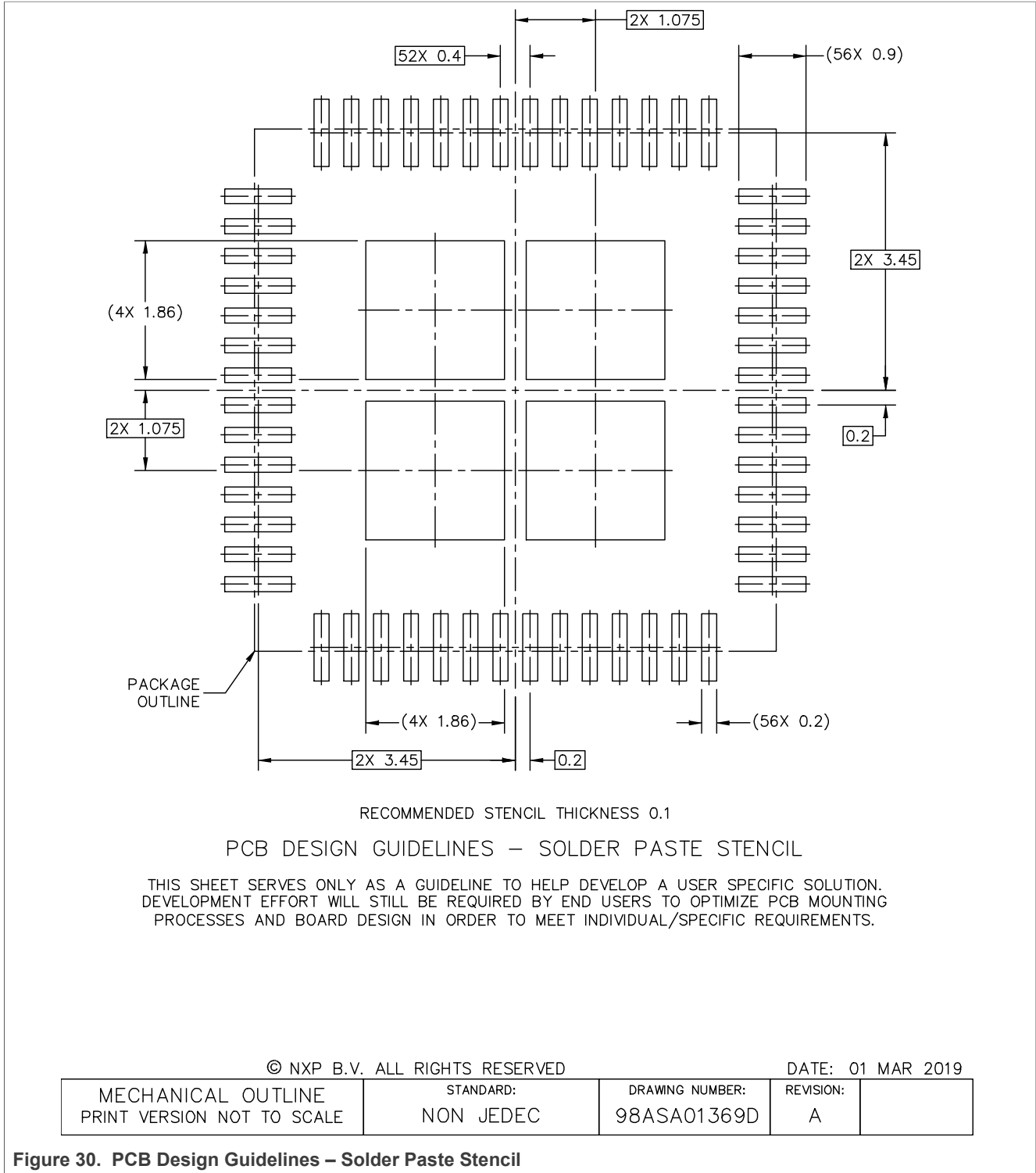

Figure 30. PCB Design Guidelines – Solder Paste Stencil

15 Revision history

Table 90. Revision history

Document ID	Release date	Data sheet status	Change notice	Supersedes
PCA9450 v2.2	20210915	Product data sheet	-	PCA9450 v2.1
Modifications:	<ul style="list-style-type: none"> • Table 2: Added T_J column • Figure 22: Updated LDO4 voltage • Table 10; Table 29: Updated bit 5:4 11b description from "Reserved" to "Cold Reset, All voltage regulators are recycled " 			
PCA9450 v2.1	20201207	Product data sheet	-	PCA9450 v2.0
Modifications:	<ul style="list-style-type: none"> • Table 3: Updated description for pin 22 SWIN • Table 20: Device_ID Register "Reset Value" changed from "0x10" to "0x11" • Table 21: RSVD bit changed from "0000" to "0001" 			
PCA9450 v2.0	20200924	Product data sheet	-	PCA9450 v1.0
Modifications:	<ul style="list-style-type: none"> • Replaced "PCA9450A" with "PCA9450AA" throughout • Table 79: Added POK information • Table 86: Updated conditions for V_{IN} and I_{OUT_MAX} • Figure 1: Corrected LDO3 capacitor value; added footnote • Figure 21, Figure 22: Added footnote • Figure 23: Corrected LDO2, added footnote • Figure 5: Corrected VINT • Section 7.3.7: Corrected paragraph 1 • Section 9.2.1.1: Corrected equations (1) and (2) 			
PCA9450 v1.0	20191119	Product data sheet	-	-

16 Legal information

16.1 Data sheet status

Document status ^{[1][2]}	Product status ^[3]	Definition
Objective [short] data sheet	Development	This document contains data from the objective specification for product development.
Preliminary [short] data sheet	Qualification	This document contains data from the preliminary specification.
Product [short] data sheet	Production	This document contains the product specification.

[1] Please consult the most recently issued document before initiating or completing a design.

[2] The term 'short data sheet' is explained in section "Definitions".

[3] The product status of device(s) described in this document may have changed since this document was published and may differ in case of multiple devices. The latest product status information is available on the Internet at URL <http://www.nxp.com>.

16.2 Definitions

Draft — A draft status on a document indicates that the content is still under internal review and subject to formal approval, which may result in modifications or additions. NXP Semiconductors does not give any representations or warranties as to the accuracy or completeness of information included in a draft version of a document and shall have no liability for the consequences of use of such information.

Short data sheet — A short data sheet is an extract from a full data sheet with the same product type number(s) and title. A short data sheet is intended for quick reference only and should not be relied upon to contain detailed and full information. For detailed and full information see the relevant full data sheet, which is available on request via the local NXP Semiconductors sales office. In case of any inconsistency or conflict with the short data sheet, the full data sheet shall prevail.

Product specification — The information and data provided in a Product data sheet shall define the specification of the product as agreed between NXP Semiconductors and its customer, unless NXP Semiconductors and customer have explicitly agreed otherwise in writing. In no event however, shall an agreement be valid in which the NXP Semiconductors product is deemed to offer functions and qualities beyond those described in the Product data sheet.

16.3 Disclaimers

Limited warranty and liability — Information in this document is believed to be accurate and reliable. However, NXP Semiconductors does not give any representations or warranties, expressed or implied, as to the accuracy or completeness of such information and shall have no liability for the consequences of use of such information. NXP Semiconductors takes no responsibility for the content in this document if provided by an information source outside of NXP Semiconductors. In no event shall NXP Semiconductors be liable for any indirect, incidental, punitive, special or consequential damages (including - without limitation - lost profits, lost savings, business interruption, costs related to the removal or replacement of any products or rework charges) whether or not such damages are based on tort (including negligence), warranty, breach of contract or any other legal theory. Notwithstanding any damages that customer might incur for any reason whatsoever, NXP Semiconductors' aggregate and cumulative liability towards customer for the products described herein shall be limited in accordance with the Terms and conditions of commercial sale of NXP Semiconductors.

Right to make changes — NXP Semiconductors reserves the right to make changes to information published in this document, including without limitation specifications and product descriptions, at any time and without

notice. This document supersedes and replaces all information supplied prior to the publication hereof.

Suitability for use — NXP Semiconductors products are not designed, authorized or warranted to be suitable for use in life support, life-critical or safety-critical systems or equipment, nor in applications where failure or malfunction of an NXP Semiconductors product can reasonably be expected to result in personal injury, death or severe property or environmental damage. NXP Semiconductors and its suppliers accept no liability for inclusion and/or use of NXP Semiconductors products in such equipment or applications and therefore such inclusion and/or use is at the customer's own risk.

Applications — Applications that are described herein for any of these products are for illustrative purposes only. NXP Semiconductors makes no representation or warranty that such applications will be suitable for the specified use without further testing or modification. Customers are responsible for the design and operation of their applications and products using NXP Semiconductors products, and NXP Semiconductors accepts no liability for any assistance with applications or customer product design. It is customer's sole responsibility to determine whether the NXP Semiconductors product is suitable and fit for the customer's applications and products planned, as well as for the planned application and use of customer's third party customer(s). Customers should provide appropriate design and operating safeguards to minimize the risks associated with their applications and products. NXP Semiconductors does not accept any liability related to any default, damage, costs or problem which is based on any weakness or default in the customer's applications or products, or the application or use by customer's third party customer(s). Customer is responsible for doing all necessary testing for the customer's applications and products using NXP Semiconductors products in order to avoid a default of the applications and the products or of the application or use by customer's third party customer(s). NXP does not accept any liability in this respect.

Limiting values — Stress above one or more limiting values (as defined in the Absolute Maximum Ratings System of IEC 60134) will cause permanent damage to the device. Limiting values are stress ratings only and (proper) operation of the device at these or any other conditions above those given in the Recommended operating conditions section (if present) or the Characteristics sections of this document is not warranted. Constant or repeated exposure to limiting values will permanently and irreversibly affect the quality and reliability of the device.

Terms and conditions of commercial sale — NXP Semiconductors products are sold subject to the general terms and conditions of commercial sale, as published at <http://www.nxp.com/profile/terms>, unless otherwise agreed in a valid written individual agreement. In case an individual agreement is concluded only the terms and conditions of the respective agreement shall apply. NXP Semiconductors hereby expressly objects to applying the customer's general terms and conditions with regard to the purchase of NXP Semiconductors products by customer.

No offer to sell or license — Nothing in this document may be interpreted or construed as an offer to sell products that is open for acceptance or the grant, conveyance or implication of any license under any copyrights, patents or other industrial or intellectual property rights.

Quick reference data — The Quick reference data is an extract of the product data given in the Limiting values and Characteristics sections of this document, and as such is not complete, exhaustive or legally binding.

Export control — This document as well as the item(s) described herein may be subject to export control regulations. Export might require a prior authorization from competent authorities.

Non-automotive qualified products — Unless this data sheet expressly states that this specific NXP Semiconductors product is automotive qualified, the product is not suitable for automotive use. It is neither qualified nor tested in accordance with automotive testing or application requirements. NXP Semiconductors accepts no liability for inclusion and/or use of non-automotive qualified products in automotive equipment or applications. In the event that customer uses the product for design-in and use in automotive applications to automotive specifications and standards, customer (a) shall use the product without NXP Semiconductors' warranty of the product for such automotive applications, use and specifications, and (b) whenever customer uses the product for automotive applications beyond NXP Semiconductors' specifications such use shall be solely at customer's own risk, and (c) customer fully indemnifies NXP Semiconductors for any liability, damages or failed product claims resulting from customer design and use of the product for automotive applications beyond NXP Semiconductors' standard warranty and NXP Semiconductors' product specifications.

Translations — A non-English (translated) version of a document is for reference only. The English version shall prevail in case of any discrepancy between the translated and English versions.

Security — Customer understands that all NXP products may be subject to unidentified or documented vulnerabilities. Customer is responsible for the design and operation of its applications and products throughout their lifecycles to reduce the effect of these vulnerabilities on customer's applications and products. Customer's responsibility also extends to other open and/or proprietary technologies supported by NXP products for use in customer's applications. NXP accepts no liability for any vulnerability. Customer should regularly check security updates from NXP and follow up appropriately. Customer shall select products with security features that best meet rules, regulations, and standards of the intended application and make the ultimate design decisions regarding its products and is solely responsible for compliance with all legal, regulatory, and security related requirements concerning its products, regardless of any information or support that may be provided by NXP. NXP has a Product Security Incident Response Team (PSIRT) (reachable at PSIRT@nxp.com) that manages the investigation, reporting, and solution release to security vulnerabilities of NXP products.

16.4 Trademarks

Notice: All referenced brands, product names, service names and trademarks are the property of their respective owners.

NXP — wordmark and logo are trademarks of NXP B.V.

Tables

Tab. 1.	Ordering information	2	Tab. 47.	0x1A BUCK4OUT	43
Tab. 2.	Ordering options	2	Tab. 48.	0x1B BUCK5CTRL	43
Tab. 3.	Pin description	4	Tab. 49.	0x1C BUCK5OUT	44
Tab. 4.	PCA9450 selection guide	8	Tab. 50.	0x1D BUCK6CTRL	44
Tab. 5.	SNVS mode	10	Tab. 51.	0x1E BUCK6OUT	44
Tab. 6.	PWRUP mode	12	Tab. 52.	BUCK4, BUCK5, BUCK6 Output voltage table	45
Tab. 7.	Power modes summary	13	Tab. 53.	0x20 LDO_AD_CTRL	46
Tab. 8.	tFLT_THSD	15	Tab. 54.	0x21 LDO1CTRL	46
Tab. 9.	tFLT_SD_WAIT	17	Tab. 55.	0x22 LDO2CTRL	47
Tab. 10.	0x08 – RESET_CTRL	18	Tab. 56.	0x23 LDO3CTRL	48
Tab. 11.	0x06 – SW_RST	18	Tab. 57.	LDO3 output voltage	48
Tab. 12.	tRESTART	19	Tab. 58.	0x24 LDO4CTRL	48
Tab. 13.	tRESET	20	Tab. 59.	LDO4 output voltage	48
Tab. 14.	PCA9450AA Regulator Control summary	20	Tab. 60.	0x25 LDO5CTRL_L	49
Tab. 15.	PCA9450B/PCA9450C Regulator Control summary	21	Tab. 61.	LDO5 output voltage when SD_VSEL = Low	49
Tab. 16.	PCA9450AA Buck Summary	22	Tab. 62.	0x26 LDO5CTRL_H	49
Tab. 17.	PCA9450C Buck Summary	22	Tab. 63.	LDO5 output voltage when SD_VSEL = High	49
Tab. 18.	LDO summary	24	Tab. 64.	0x2A LOADSW_CTRL	50
Tab. 19.	PCA9450 I2C Slave Address	27	Tab. 65.	0x2B VRFLT1_STS	50
Tab. 20.	Register map	28	Tab. 66.	0x2C VRFLT2_STS	51
Tab. 21.	0x00 Device_ID	31	Tab. 67.	0x2D VRFLT1_MASK	52
Tab. 22.	0x01 INT1	31	Tab. 68.	0x2E VRFLT2_MASK	52
Tab. 23.	0x02 INT1_MSK	32	Tab. 69.	Tested inductor list	58
Tab. 24.	0x03 STATUS1	32	Tab. 70.	Limiting values	63
Tab. 25.	0x04 STATUS2	33	Tab. 71.	Recommended Operating Conditions	64
Tab. 26.	0x05 PWRON_STAT	34	Tab. 72.	Thermal characteristics	65
Tab. 27.	0x06 SW_RST	34	Tab. 73.	Top level parameter	66
Tab. 28.	0x07 PWR_CTRL	34	Tab. 74.	I2C level translator	69
Tab. 29.	0x08 RESET_CTRL	35	Tab. 75.	BUCK1 (PCA9450AA/PCA9450B)	70
Tab. 30.	0x09 CONFIG1	36	Tab. 76.	Dual Phase BUCK1 (PCA9450C)	71
Tab. 31.	0x0A CONFIG2	36	Tab. 77.	BUCK2	72
Tab. 32.	0x0C BUCK123_DVS	37	Tab. 78.	BUCK3 (PCA9450AA)	73
Tab. 33.	0x0D BUCK1OUT_LIMIT	37	Tab. 79.	BUCK4	74
Tab. 34.	0x0E BUCK2OUT_LIMIT	37	Tab. 80.	BUCK5	75
Tab. 35.	0x0F BUCK3OUT_LIMIT	38	Tab. 81.	BUCK6	76
Tab. 36.	0x10 BUCK1CTRL	38	Tab. 82.	LDO1	77
Tab. 37.	0x11 BUCK1OUT_DVS0	39	Tab. 83.	LDO2	78
Tab. 38.	0x12 BUCK1OUT_DVS1	39	Tab. 84.	LDO3	79
Tab. 39.	0x13 BUCK2CTRL	39	Tab. 85.	LDO4	80
Tab. 40.	0x14 BUCK2OUT_DVS0	40	Tab. 86.	LDO5	81
Tab. 41.	0x15 BUCK2OUT_DVS1	40	Tab. 87.	Load SW	82
Tab. 42.	0x16 BUCK3CTRL	40	Tab. 88.	32 kHz Xtal driver	83
Tab. 43.	0x17 BUCK3OUT_DVS0	41	Tab. 89.	I2C-bus interface and logic I/O	84
Tab. 44.	0x18 BUCK3OUT_DVS1	41	Tab. 90.	Revision history	90
Tab. 45.	BUCK1, BUCK2, BUCK3 Output voltage table	42			
Tab. 46.	0x19 BUCK4CTRL	43			

Figures

Fig. 1.	Block diagram	3	Fig. 5.	SNVS mode ON/OFF sequence	10
Fig. 2.	PCA9450 pin map – Top View	4	Fig. 6.	PCA9450AA power ON/OFF sequence	11
Fig. 3.	PCA9450 functional block diagram	8	Fig. 7.	PCA9450B/C power ON/OFF sequence	12
Fig. 4.	Power States Diagram	9	Fig. 8.	PCA9450AA mode transition	13

Fig. 9.	PCA9450 FAULT_SD from Thermal shutdown	15	Fig. 20.	Interrupt diagram	27
Fig. 10.	PCA9450 Fault event	16	Fig. 21.	PCA9450AA application schematic	55
Fig. 11.	PCA9450 FAULT_SD from VR Fault except LDO1/LDO2 in RUN/STANDBY	17	Fig. 22.	PCA9450B application schematic	56
Fig. 12.	PCA9450AA Cold reset	19	Fig. 23.	PCA9450C application schematic	57
Fig. 13.	Warm reset	20	Fig. 24.	Crystal oscillator	60
Fig. 14.	DVS functional diagram	23	Fig. 25.	PCA9450 layout	62
Fig. 15.	DVS timing	23	Fig. 26.	Package outline HVQFN56 (SOT949-6)	85
Fig. 16.	BUCK1/3 configuration	24	Fig. 27.	Package outline HVQFN56 (SOT949-6)	86
Fig. 17.	32 kHz Crystal oscillator driver block diagram	25	Fig. 28.	PCB Design Guidelines – Solder Mask Opening Pattern	87
Fig. 18.	Load switch internal block diagram	25	Fig. 29.	PCB Design Guidelines - I/O PADS AND SODERABLE AREA	88
Fig. 19.	Architecture of I2C Level translator (One channel)	26	Fig. 30.	PCB Design Guidelines – Solder Paste Stencil	89

Contents

1	General description	1	8.2.22	0x16 BUCK3CTRL	40
2	Features and benefits	1	8.2.23	0x17 BUCK3OUT_DVS0	41
3	Applications	2	8.2.24	0x18 BUCK3OUT_DVS1	41
4	Ordering information	2	8.2.25	0x19 BUCK4CTRL	42
5	Block diagram	3	8.2.26	0x1A BUCK4OUT	43
6	Pinning information	4	8.2.27	0x1B BUCK5CTRL	43
6.1	Pinning	4	8.2.28	0x1C BUCK5OUT	44
6.2	Pin description	4	8.2.29	0x1D BUCK6CTRL	44
7	Functional description	7	8.2.30	0x1E BUCK6OUT	44
7.1	Features	7	8.2.31	0x20 LDO_AD_CTRL	46
7.2	Functional diagram	8	8.2.32	0x21 LDO1CTRL	46
7.3	Power modes	9	8.2.33	0x22 LDO2CTRL	47
7.3.1	Off mode	9	8.2.34	0x23 LDO3CTRL	47
7.3.2	READY mode	9	8.2.35	0x24 LDO4CTRL	48
7.3.3	SNVS mode	9	8.2.36	0x25 LDO5CTRL_L	49
7.3.4	PWRUP mode	10	8.2.37	0x26 LDO5CTRL_H	49
7.3.5	PWRDN mode	12	8.2.38	0x2A LOADSW_CTRL	50
7.3.6	RUN mode	12	8.2.39	0x2B VRFLT1_STS	50
7.3.7	STANDBY mode	13	8.2.40	0x2C VRFLT2_STS	51
7.3.8	FAULT_SD	14	8.2.41	0x2D VRFLT1_MASK	52
7.4	PMIC reset	18	8.2.42	0x2E VRFLT2_MASK	52
7.5	Regulator control in each power mode	20	9	Application design-in information	54
7.6	Regulator summary	21	9.1	Reference schematic	54
7.6.1	BUCK regulator	21	9.1.1	PCA9450AA reference schematic	54
7.6.1.1	Dynamic voltage scaling	22	9.1.2	PCA9450B reference schematic	56
7.6.1.2	BUCK output voltage limiting	23	9.1.3	PCA9450C reference schematic	57
7.6.1.3	Dual-phase configuration	23	9.2	Typical application	58
7.6.2	LDO and load switch	24	9.2.1	Buck regulators	58
7.7	32 kHz Crystal Oscillator Driver	24	9.2.1.1	Inductor selection for buck converters	58
7.8	Load switch	25	9.2.1.2	Output capacitor selection for buck converters	59
7.9	I2C level translator	25	9.2.1.3	Input capacitor selection for buck converters	59
7.10	Interrupt management	26	9.2.2	Crystal oscillator	59
8	Software interface	27	9.2.2.1	Crystal selection	59
8.1	Register map	28	9.2.2.2	Effective load capacitance	60
8.2	Register details	31	9.2.2.3	Frequency tuning	61
8.2.1	0x00 Device_ID	31	9.3	Layout guide	61
8.2.2	0x01 INT1	31	10	Limiting values	63
8.2.3	0x02 INT1_MSK	32	11	Recommended operating conditions	64
8.2.4	0x03 STATUS1	32	12	Thermal characteristics	65
8.2.5	0x04 STATUS2	33	13	Electrical characteristics	66
8.2.6	0x05 PWRON_STAT	33	13.1	Top level parameter	66
8.2.7	0x06 SW_RST	34	13.2	I2C level translator	69
8.2.8	0x07 PWR_CTRL	34	13.3	BUCK1 (PCA9450AA/PCA9450B)	70
8.2.9	0x08 RESET_CTRL	35	13.4	Dual Phase BUCK1 (PCA9450C)	71
8.2.10	0x09 CONFIG1	36	13.5	BUCK2	72
8.2.11	0x0A CONFIG2	36	13.6	BUCK3 (PCA9450AA)	73
8.2.12	0x0C BUCK123_DVS	37	13.7	BUCK4	74
8.2.13	0x0D BUCK1OUT_LIMIT	37	13.8	BUCK5	75
8.2.14	0x0E BUCK2OUT_LIMIT	37	13.9	BUCK6	76
8.2.15	0x0F BUCK3OUT_LIMIT	38	13.10	LDO1	77
8.2.16	0x10 BUCK1CTRL	38	13.11	LDO2	78
8.2.17	0x11 BUCK1OUT_DVS0	39	13.12	LDO3	79
8.2.18	0x12 BUCK1OUT_DVS1	39	13.13	LDO4	80
8.2.19	0x13 BUCK2CTRL	39	13.14	LDO5	81
8.2.20	0x14 BUCK2OUT_DVS0	40			
8.2.21	0x15 BUCK2OUT_DVS1	40			

13.15 Load SW82
13.16 32 kHz Xtal driver 83
13.17 I2C-bus interface and logic I/O 84
14 Package outline85
15 Revision history 90
16 Legal information 91

Please be aware that important notices concerning this document and the product(s) described herein, have been included in section 'Legal information'.

© NXP B.V. 2021.

All rights reserved.

For more information, please visit: <http://www.nxp.com>

For sales office addresses, please send an email to: salesaddresses@nxp.com

Date of release: 15 September 2021
Document identifier: PCA9450