



**KERSEMI**

**P0102BL**  
0.25A SCR's

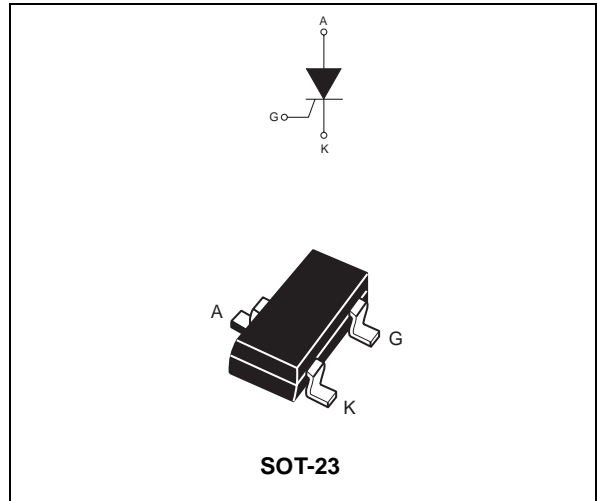
**MAIN FEATURES:**

Symbol	Value	Unit
$I_{T(RMS)}$	0.25	A
$V_{DRM}/V_{RRM}$	200	V
$I_{GT}$	200	$\mu A$

**DESCRIPTION**

Thanks to highly sensitive triggering levels, the PO102BL SCR is suitable for all applications where the available gate current is limited such as stand-by mode power supplies, smoke and alarm detectors...

Available in SOT-23, it provides optimized space saving on high density printed circuit boards.



**ABSOLUTE RATINGS** (limiting values)

Symbol	Parameter		Value	Unit	
$I_{T(RMS)}$	RMS on-state current (180° conduction angle)		$T_{amb} = 30^{\circ}C$	0.25 A	
$I_{T(AV)}$	Average on-state current (180° conduction angle)		$T_{amb} = 30^{\circ}C$	0.17 A	
$I_{TSM}$	Non repetitive surge peak on-state current	$t_p = 8.3 \text{ ms}$	$T_j = 25^{\circ}C$	7	A
		$t_p = 10 \text{ ms}$		6	
$I^2t$	$I^2t$ Value for fusing	$t_p = 10 \text{ ms}$	$T_j = 25^{\circ}C$	0.18	$A^2s$
$di/dt$	Critical rate of rise of on-state current $I_G = 2 \times I_{GT}, t_r \leq 100ns$	F = 60 Hz	$T_j = 125^{\circ}C$	50	$A/\mu s$
$I_{GM}$	Peak gate current	$t_p = 20 \mu s$	$T_j = 125^{\circ}C$	0.5	A
$P_{G(AV)}$	Average gate power dissipation		$T_j = 125^{\circ}C$	0.02	W
$T_{stg}$ $T_j$	Storage junction temperature range Operating junction temperature range			- 40 to + 150 - 40 to + 125	$^{\circ}C$

**ELECTRICAL CHARACTERISTICS** (T<sub>j</sub> = 25°C, unless otherwise specified)

Symbol	Test Conditions		P0102BL	Unit	
I <sub>GT</sub>	V <sub>D</sub> = 12 V R <sub>L</sub> = 140 Ω	MAX.	200	μA	
V <sub>GT</sub>		MAX.	0.8	V	
V <sub>GD</sub>	V <sub>D</sub> = V <sub>DRM</sub> R <sub>L</sub> = 3.3 kΩ R <sub>GK</sub> = 1 kΩ	T <sub>j</sub> = 125°C	MIN.	0.1	V
V <sub>RG</sub>	I <sub>RG</sub> = 10 μA		MIN.	8	V
I <sub>H</sub>	I <sub>T</sub> = 50 mA R <sub>GK</sub> = 1kΩ		MAX.	6	mA
I <sub>L</sub>	I <sub>G</sub> = 1 mA R <sub>GK</sub> = 1kΩ		MAX.	7	mA
dV/dt	V <sub>D</sub> = 67 % V <sub>DRM</sub> R <sub>GK</sub> = 1kΩ	T <sub>j</sub> = 125°C	MIN.	200	V/μs
V <sub>TM</sub>	I <sub>TM</sub> = 0.4 A tp = 380 μs	T <sub>j</sub> = 25°C	MAX.	1.7	V
V <sub>T0</sub>	Threshold voltage	T <sub>j</sub> = 125°C	MAX.	1.0	V
R <sub>d</sub>	Dynamic resistance	T <sub>j</sub> = 125°C	MAX.	1000	mΩ
I <sub>DRM</sub>	V <sub>DRM</sub> = V <sub>RRM</sub>	T <sub>j</sub> = 25°C	MAX.	1	μA
I <sub>RRM</sub>		T <sub>j</sub> = 125°C		100	

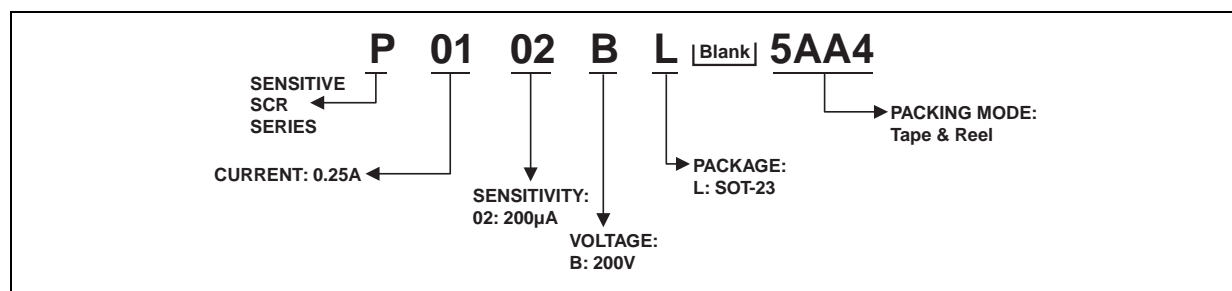
**THERMAL RESISTANCES**

Symbol	Parameter	Value	Unit
R <sub>th(j-a)</sub>	Junction to ambient (mounted on FR4 with recommended pad layout)	400	°C/W

**PRODUCT SELECTOR**

Part Number	Voltage	Sensitivity	Package
P0102BL	200 V	200 μA	SOT-23

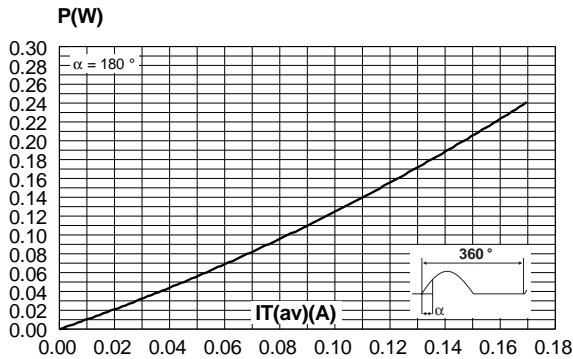
**ORDERING INFORMATION**



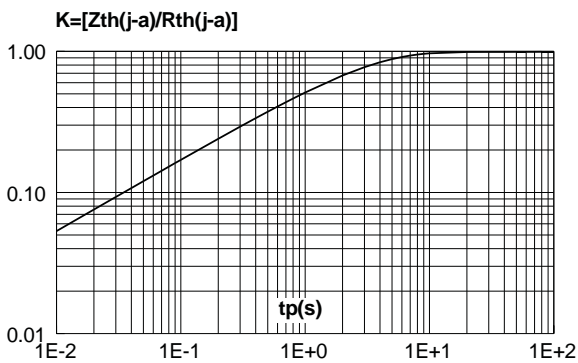
**OTHER INFORMATION**

Part Number	Marking	Weight	Base quantity	Packing mode
P0102BL	P2B	0.01 g	3000	Tape & reel

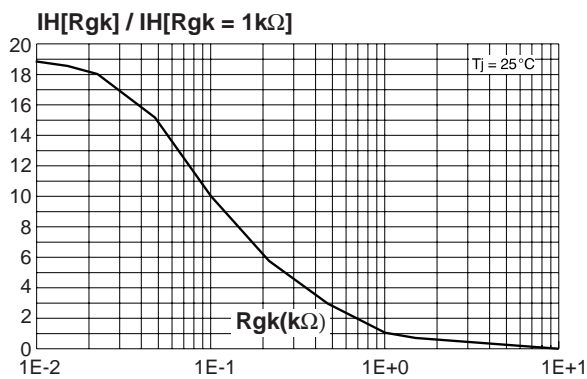
**Fig. 1:** Maximum average power dissipation versus average on-state current.



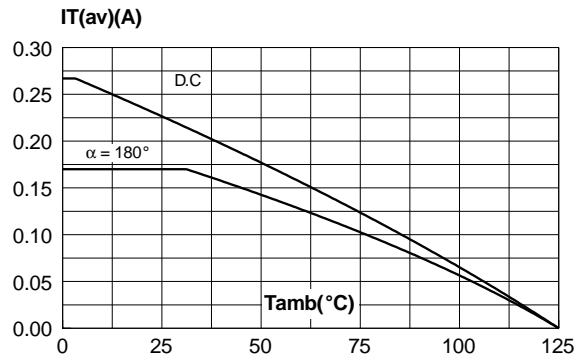
**Fig. 3:** Relative variation of thermal impedance junction to ambient versus pulse duration.



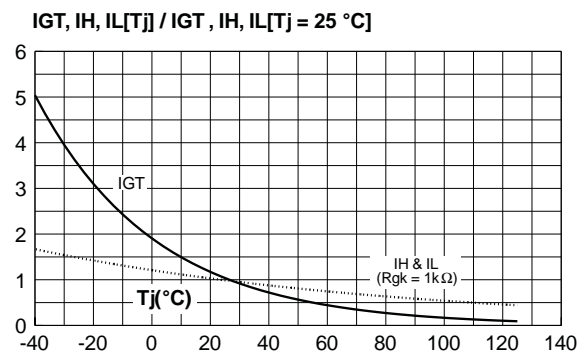
**Fig. 5:** Relative variation of holding current versus gate-cathode resistance (typical values).



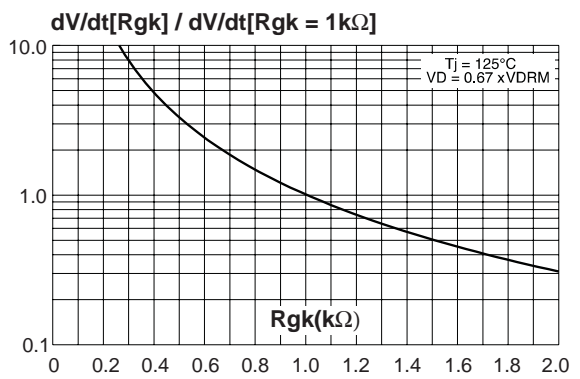
**Fig. 2:** Average and D.C. on-state current versus ambient temperature.



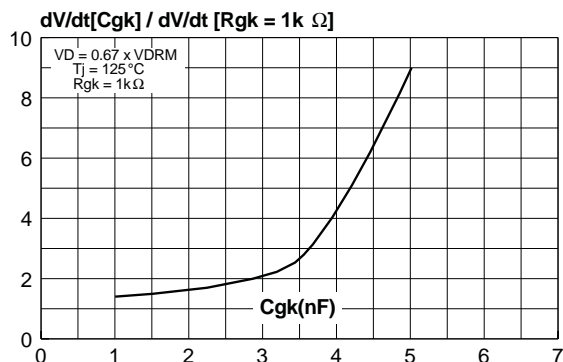
**Fig. 4:** Relative variation of gate trigger current, holding current and latching current versus junction temperature (typical values).



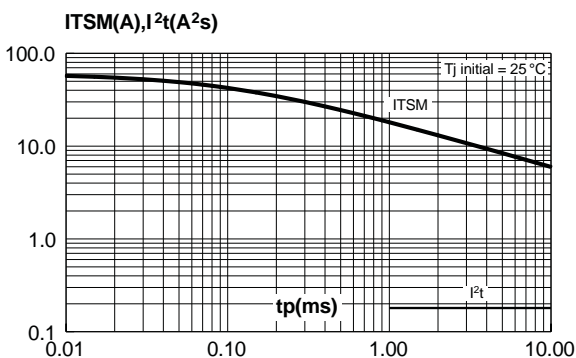
**Fig. 6:** Relative variation of dV/dt immunity versus gate-cathode resistance (typical values).



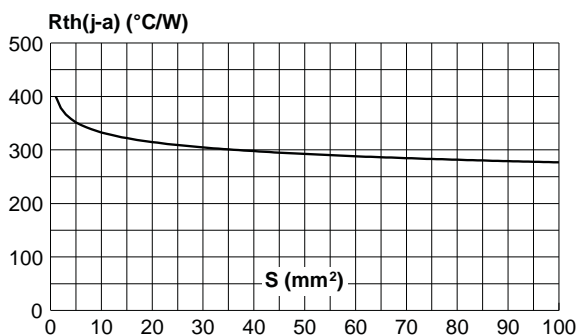
**Fig. 7:** Relative variation of dV/dt immunity versus gate-cathode capacitance (typical values).



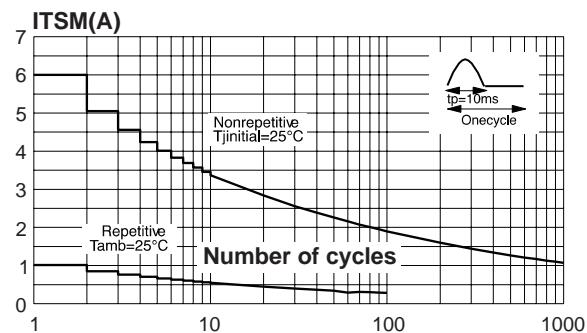
**Fig. 9:** Non-repetitive surge peak on-state current for a sinusoidal pulse with width  $t_p < 10ms$ , and corresponding value of  $I^2t$ .



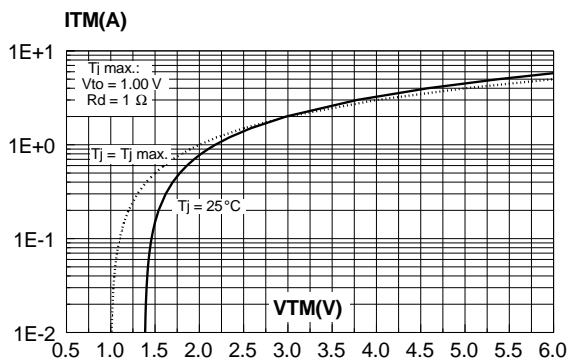
**Fig. 11:** Thermal resistance junction to ambient versus copper surface under tab (Epoxy printed circuit board FR4, copper thickness: 35  $\mu m$ ).



**Fig. 8:** Surge peak on-state current versus number of cycles.

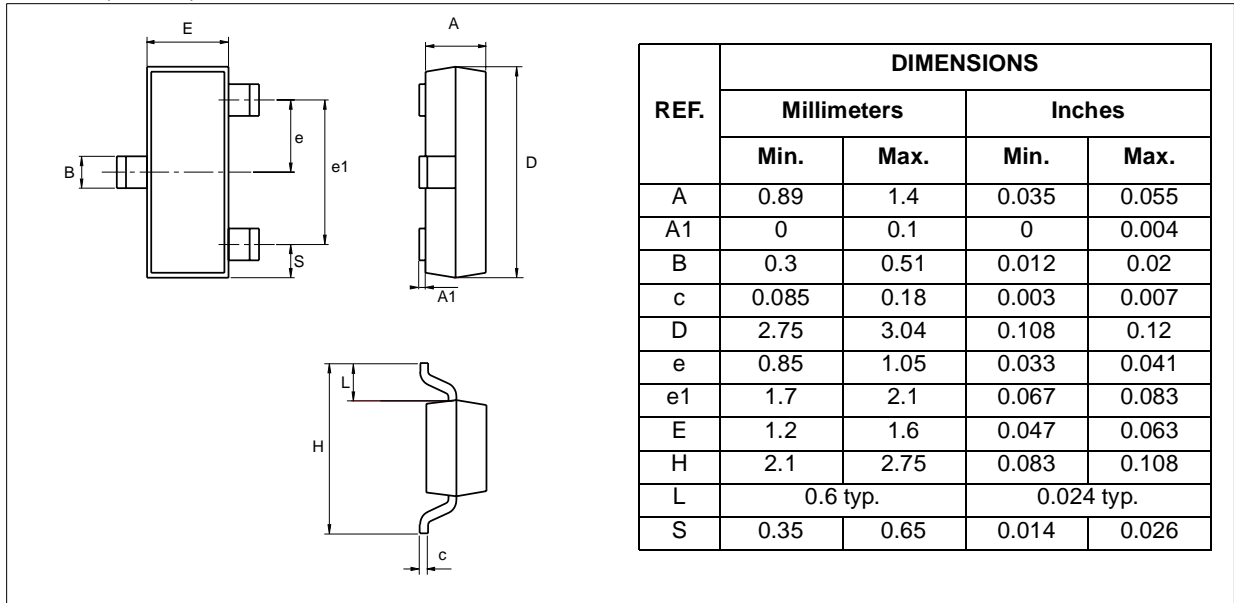


**Fig. 10:** On-state characteristics (maximum values).



**PACKAGE MECHANICAL DATA**

SOT-23 (Plastic)



**FOOTPRINT DIMENSIONS (in millimeters)**

SOT-23 (Plastic)

