



1.8V, 1 μ A max, Zero-Crossover RAIL-TO-RAIL I/O OPERATIONAL AMPLIFIER

FEATURES

- ZERØ-CROSSOVER
- LOW POWER: 1 μ A (max)
- LOW OFFSET VOLTAGE: 750 μ V (max)
- LOW VOLTAGE SUPPLY: +1.8V to +5.5V
- LOW OFFSET DRIFT: 1.75 μ V/ $^{\circ}$ C (max)
- *micro*SIZE PACKAGES:
 - SC70-5, SOT23-8, MSOP-8

APPLICATIONS

- BATTERY-POWERED INSTRUMENTS
- PORTABLE DEVICES
- MEDICAL INSTRUMENTS
- TEST EQUIPMENT

DESCRIPTION

The OPA369 and OPA2369 are new low-power, low-voltage operational amplifiers from Texas Instruments designed especially for battery-powered applications.

The OPAx369 operates on a supply voltage as low as 1.8V and has true rail-to-rail operation that makes it useful for a wide range of applications. The *zero-crossover* feature resolves the problem of input crossover distortion that becomes very prominent in low voltage (< 3V), rail-to-rail input applications.

In addition to *micro*size packages and very low quiescent current (1 μ A, max) the OPAx369 features 12kHz bandwidth, low offset drift (1.75 μ V/ $^{\circ}$ C, max), and low 0.1Hz to 10Hz noise (3.6 μ V_{PP}).

The OPA369 (single version, available Q4 2007) is offered in an SC70-5 package. The OPA2369 (dual version) comes in both MSOP-8 and SOT23-8 packages.

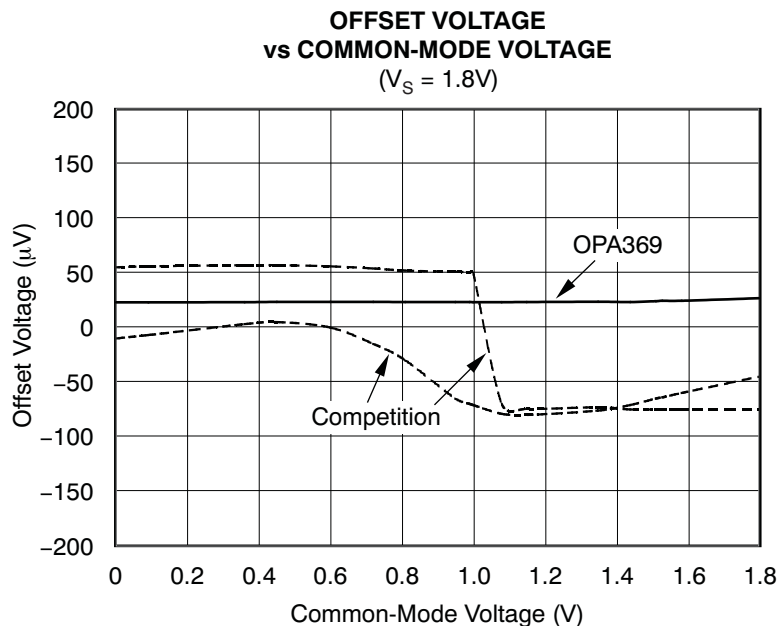

Please be aware that an important notice concerning availability, standard warranty, and use in critical applications of Texas Instruments semiconductor products and disclaimers thereto appears at the end of this data sheet.

All trademarks are the property of their respective owners.



This integrated circuit can be damaged by ESD. Texas Instruments recommends that all integrated circuits be handled with appropriate precautions. Failure to observe proper handling and installation procedures can cause damage.

ESD damage can range from subtle performance degradation to complete device failure. Precision integrated circuits may be more susceptible to damage because very small parametric changes could cause the device not to meet its published specifications.

ABSOLUTE MAXIMUM RATINGS⁽¹⁾

Over operating free-air temperature range (unless otherwise noted).

		VALUE	UNIT
Supply Voltage, $V_S = (V+) - (V-)$		+7V	V
Single Input Terminals	Voltage ⁽²⁾	-0.5 to (V+) + 0.5	V
	Current ⁽²⁾	±10	mA
Output Short-Circuit ⁽³⁾		Continuous	
Operating Temperature, T_A		-55 to +125	°C
Storage Temperature, T_A		-65 to +150	°C
Junction Temperature, T_J		+150	°C
ESD Ratings	Human Body Model (HBM)	4000	V
	Charged Device Model (CDM)	1000	V
	Machine Model (MM)	200	V

- (1) Stresses above these ratings may cause permanent damage. Exposure to absolute maximum conditions for extended periods may degrade device reliability. These are stress ratings only, and functional operation of the device at these or any other conditions beyond those specified is not supported.
- (2) Input terminals are diode-clamped to the power-supply rails. Input signals that can swing more than 0.5V beyond the supply rails should be current limited to 10mA or less.
- (3) Short-circuit to $V_S/2$, one amplifier per package.

PACKAGE/ORDERING INFORMATION⁽¹⁾

PRODUCT	PACKAGE-LEAD	PACKAGE DESIGNATOR	PACKAGE MARKING
OPA369	SC70-5 ⁽²⁾	DCK	CJS
OPA2369	MSOP-8	DGK	OCCQ
	SOT23-8	DCN	OCBQ

- (1) For the most current package and ordering information see the Package Option Addendum at the end of this document, or see the TI web site at www.ti.com.
- (2) Available Q4, 2007.

PIN CONFIGURATIONS

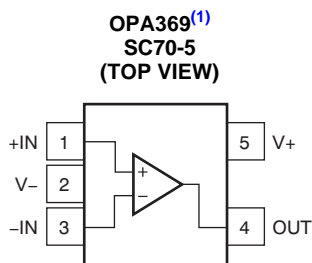

(1) Available Q4, 2007.

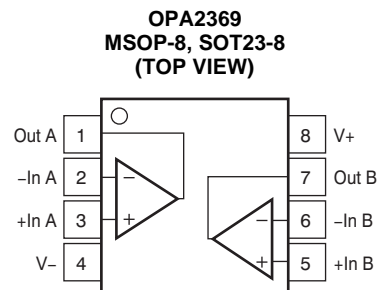

ELECTRICAL CHARACTERISTICS: $V_S = +1.8V$ to $+5.5V$
BOLDFACE limits apply over the specified temperature range, $T_A = -40^\circ\text{C}$ to $+85^\circ\text{C}$.

 At $T_A = +25^\circ\text{C}$, $R_L = 100\text{k}\Omega$ connected to $V_S/2$, unless otherwise noted.

PARAMETER	CONDITIONS	OPA369 ⁽¹⁾ , OPA2369			UNIT
		MIN	TYP	MAX	
OFFSET VOLTAGE					
Input Offset Voltage	V_{OS}		250	750	μV
over Temperature				1	mV
Drift	dV_{OS}/dT		0.4	1.75	$\mu\text{V}/^\circ\text{C}$
vs Power Supply	PSRR	$V_S = 1.8V$ to $5.5V$	5	20	$\mu\text{V}/V$
Channel Separation		dc	0.1		$\mu\text{V}/V$
		$f = 1\text{kHz}$	120		dB
INPUT VOLTAGE RANGE					
Common-Mode Voltage Range	V_{CM}		(V–)	(V+)	V
Common-Mode Rejection Ratio	CMRR	$(V-) \leq V_{CM} \leq (V+)$	100	114	dB
over Temperature		$(V-) \leq V_{CM} \leq (V+)$	90		dB
INPUT BIAS CURRENT					
Input Bias Current	I_B		10	50	pA
Input Offset Current	I_{OS}		10	50	pA
INPUT IMPEDANCE					
Differential			$10^{13} \parallel 3$		$\Omega \parallel \text{pF}$
Common-Mode			$10^{13} \parallel 6$		$\Omega \parallel \text{pF}$
NOISE					
Input Voltage Noise		$f = 0.1\text{Hz}$ to 10Hz	3.6		μV_{PP}
Input Voltage Noise Density		$f = 100\text{Hz}$	160		$\text{nV}/\sqrt{\text{Hz}}$
		$f = 1\text{kHz}$	120		$\text{nV}/\sqrt{\text{Hz}}$
Current Noise Density		$f = 1\text{kHz}$	1		$\text{fA}/\sqrt{\text{Hz}}$
OPEN-LOOP GAIN					
Open-Loop Voltage Gain	A_{OL}	$100\text{mV} \leq V_O \leq (V+) - 100\text{mV}$, $R_L = 100\text{k}\Omega$	114	134	dB
Over Temperature		$100\text{mV} \leq V_O \leq (V+) - 100\text{mV}$, $R_L = 100\text{k}\Omega$	100		dB
		$500\text{mV} \leq V_O \leq (V+) - 500\text{mV}$, $R_L = 10\text{k}\Omega$	114	134	dB
Over Temperature		$500\text{mV} \leq V_O \leq (V+) - 500\text{mV}$, $R_L = 10\text{k}\Omega$	90		dB
OUTPUT					
Voltage Output Swing from Rail		$R_L = 100\text{k}\Omega$ $R_L = 10\text{k}\Omega$		10 25	mV mV
Short-Circuit Current	I_{SC}		10		mA
Capacitive Load Drive	C_{LOAD}		See Typical Characteristics		pF
FREQUENCY RESPONSE					
Gain-Bandwidth Product	GBW			12	kHz
Slew Rate	SR	$G = +1$		0.005	V/ μs
Overload Recovery Time		$V_{IN} \times \text{Gain} > V_S$		250	μs
POWER SUPPLY					
Specified Voltage	V_S		1.8	5.5	V
Quiescent Current (per channel amplifier)	I_Q	$I_{OUT} = 0A$	0.7	1	μA
Over Temperature				1.25	μA

(1) OPA369 specifications are preview. Available Q4, 2007.

ELECTRICAL CHARACTERISTICS: $V_S = +1.8V$ to $+5.5V$ (continued)

BOLDFACE limits apply over the specified temperature range, $T_A = -40^\circ C$ to $+85^\circ C$.
At $T_A = +25^\circ C$, $R_L = 100k\Omega$ connected to $V_S/2$, unless otherwise noted.

PARAMETER	CONDITIONS	OPA369 ⁽¹⁾ , OPA2369			UNIT
		MIN	TYP	MAX	
TEMPERATURE RANGE					
Specified Range	T_A	-40		+85	$^\circ C$
Operating Range	T_A	-55		+125	$^\circ C$
Thermal Resistance	θ_{JA}				
SC70			250		$^\circ C/W$
SOT23			223		$^\circ C/W$
MSOP			252		$^\circ C/W$

TYPICAL CHARACTERISTICS

At $T_A = +25^\circ\text{C}$, $V_S = 5\text{V}$, $R_L = 100\text{k}\Omega$ connected to $V_S/2$, unless otherwise noted.

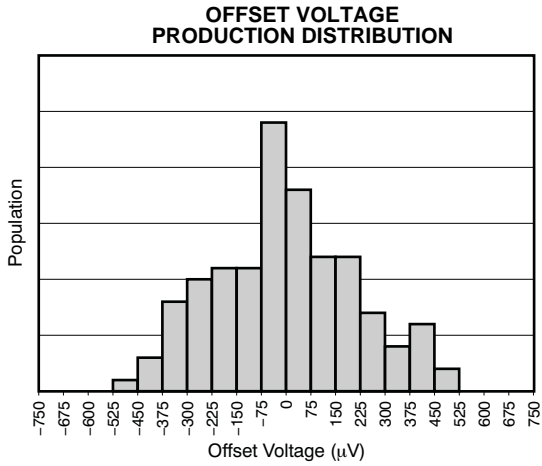

Figure 1.

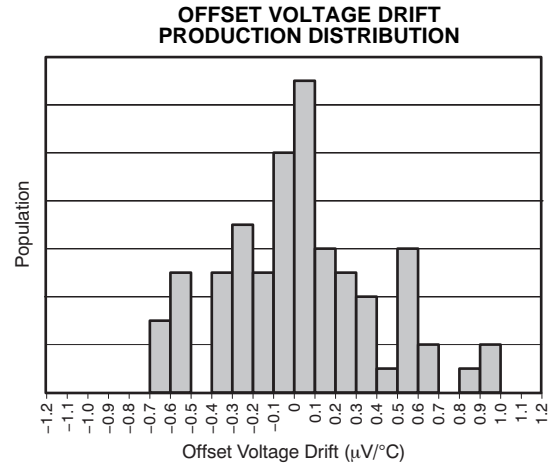

Figure 2.

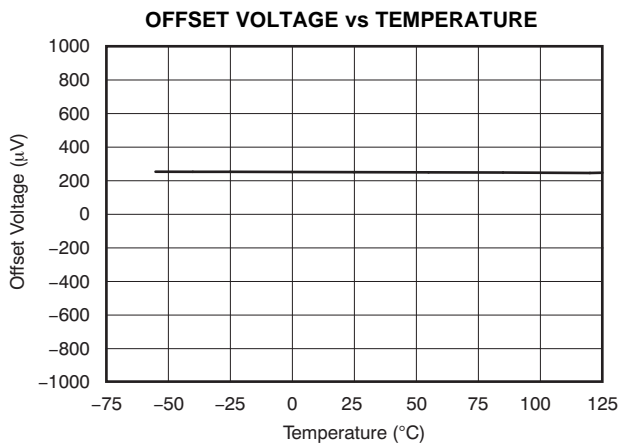

Figure 3.

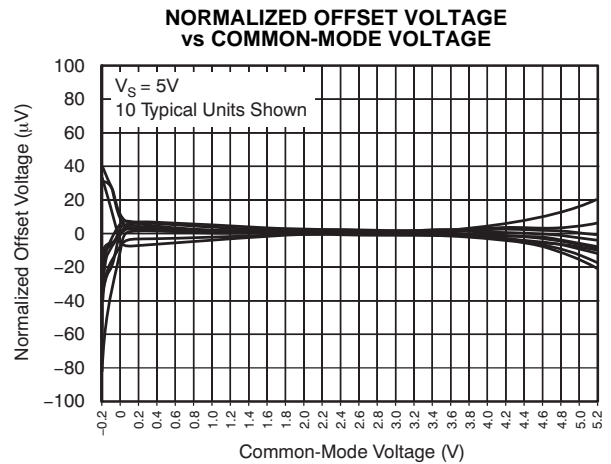

Figure 4.

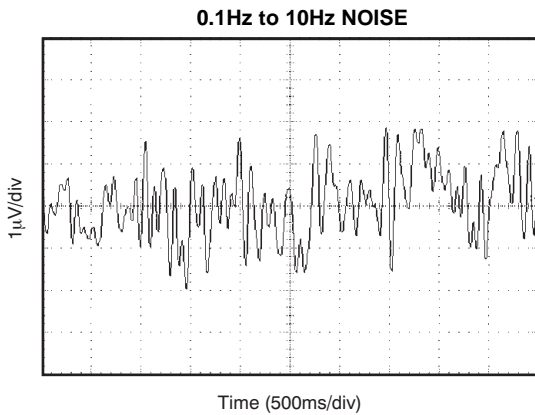

Figure 5.

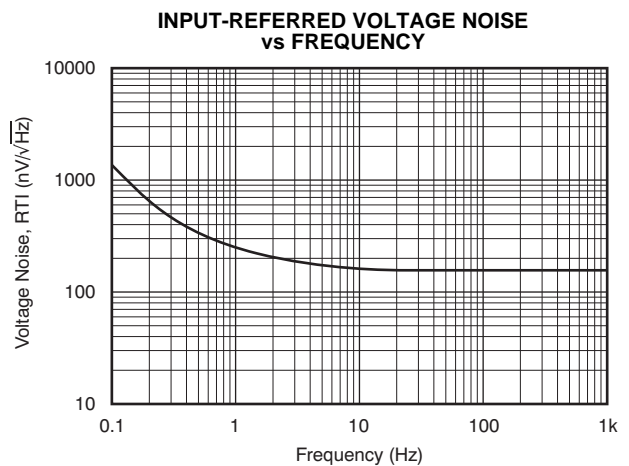

Figure 6.

TYPICAL CHARACTERISTICS (continued)

At $T_A = +25^\circ\text{C}$, $V_S = 5\text{V}$, $R_L = 100\text{k}\Omega$ connected to $V_S/2$, unless otherwise noted.

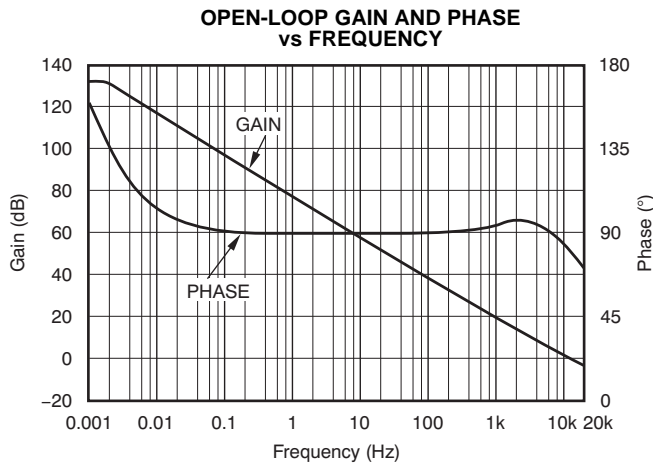

Figure 7.

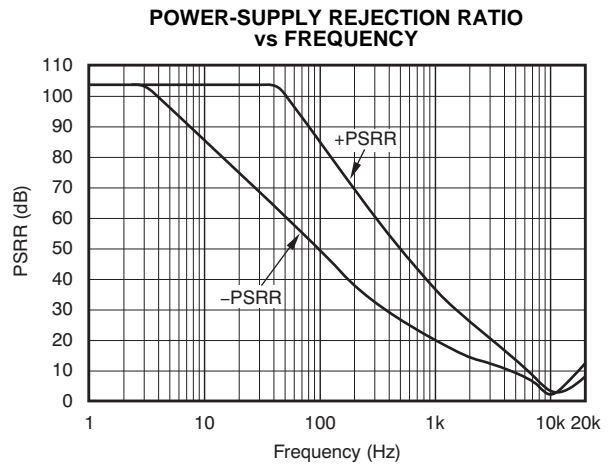

Figure 8.

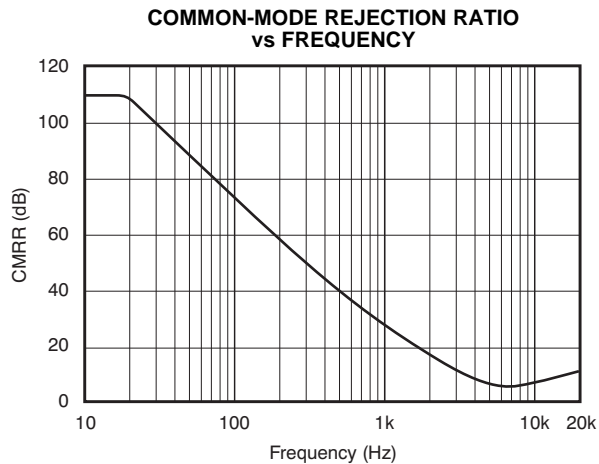

Figure 9.

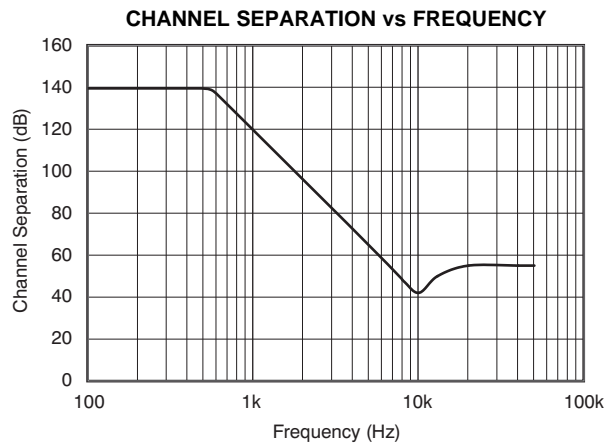

Figure 10.

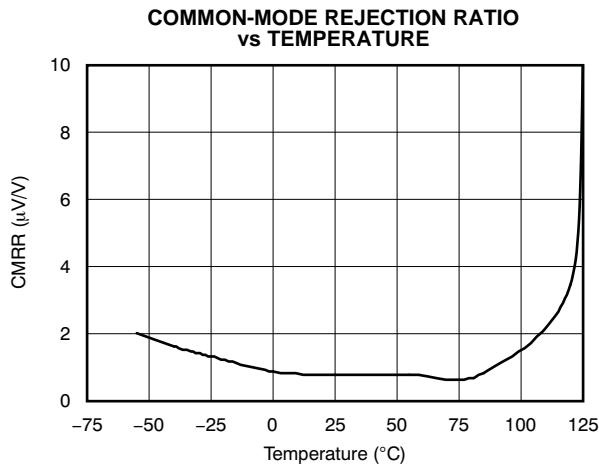

Figure 11.

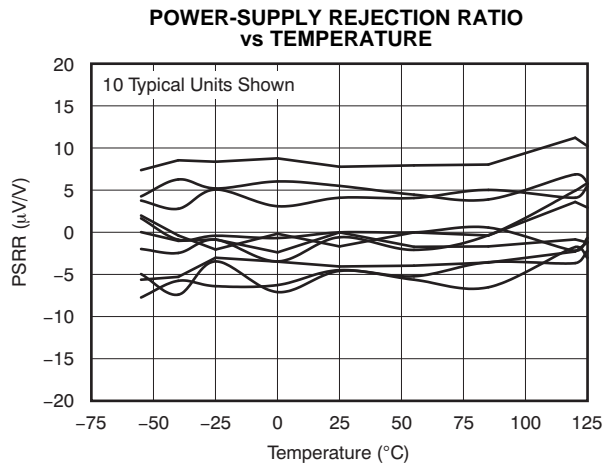

Figure 12.

TYPICAL CHARACTERISTICS (continued)

At $T_A = +25^\circ\text{C}$, $V_S = 5\text{V}$, $R_L = 100\text{k}\Omega$ connected to $V_S/2$, unless otherwise noted.

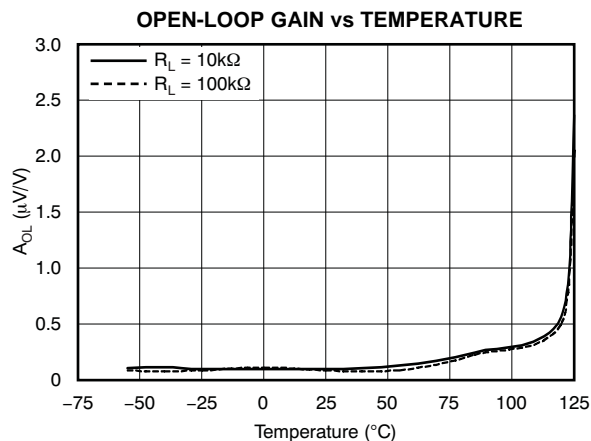

Figure 13.

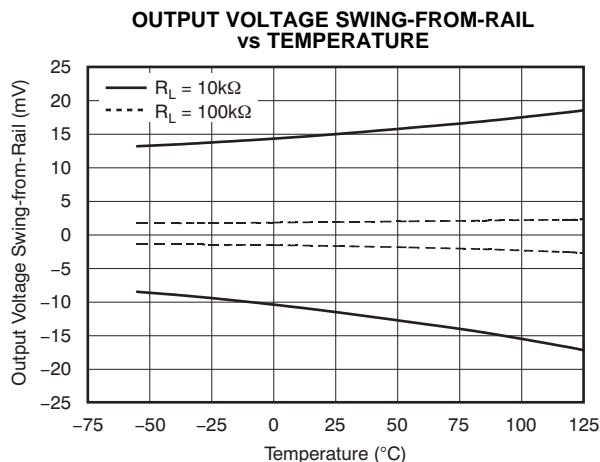

Figure 14.

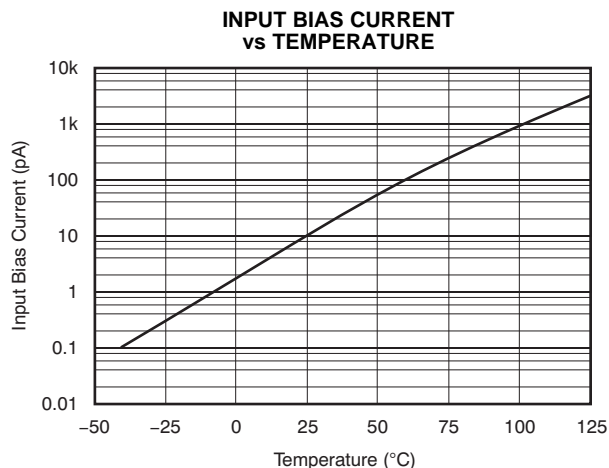

Figure 15.

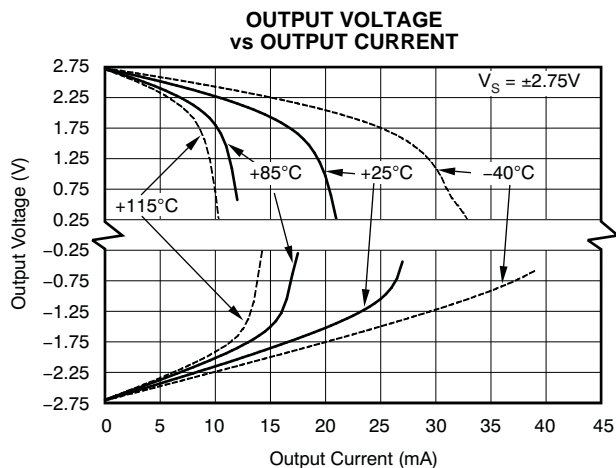

Figure 16.

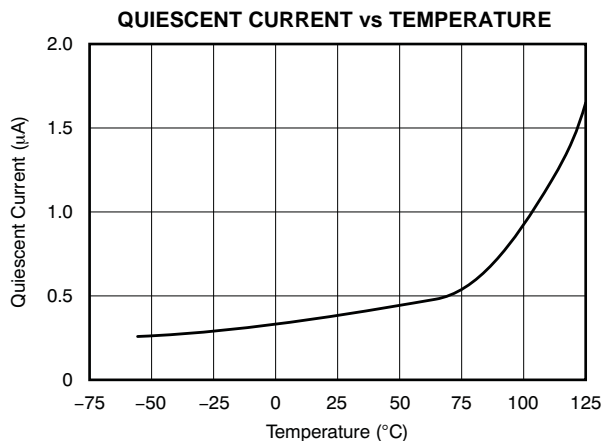

Figure 17.

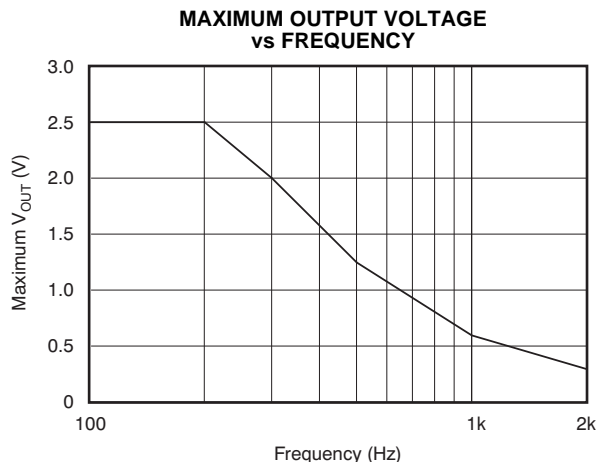

Figure 18.

TYPICAL CHARACTERISTICS (continued)

At $T_A = +25^\circ\text{C}$, $V_S = 5\text{V}$, $R_L = 100\text{k}\Omega$ connected to $V_S/2$, unless otherwise noted.

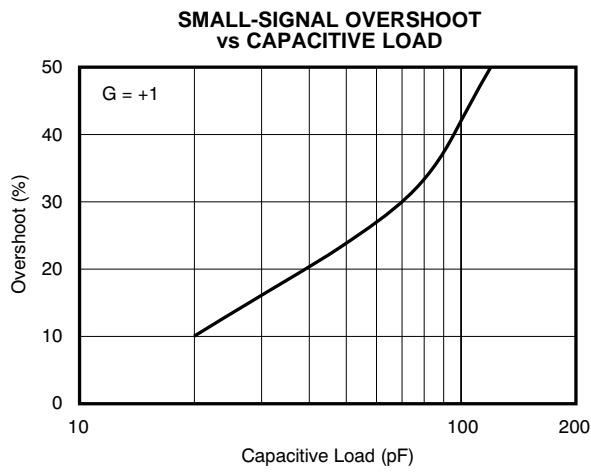

Figure 19.

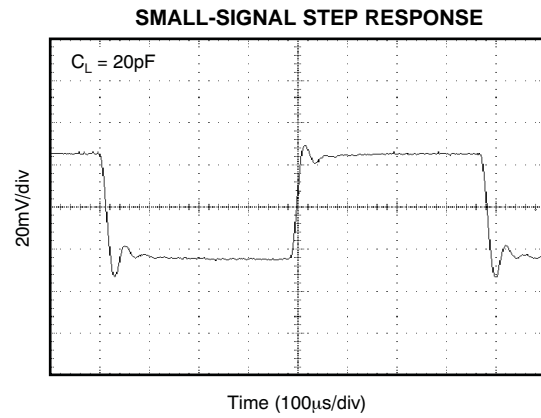

Figure 20.

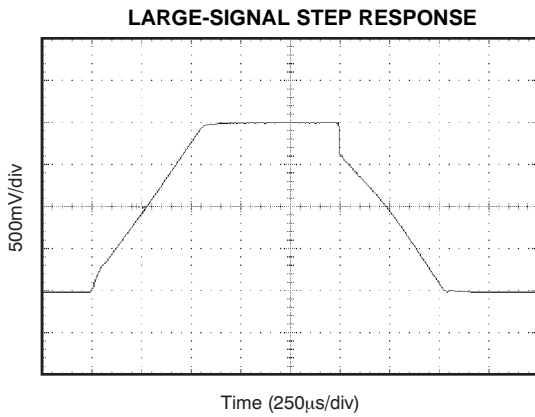

Figure 21.

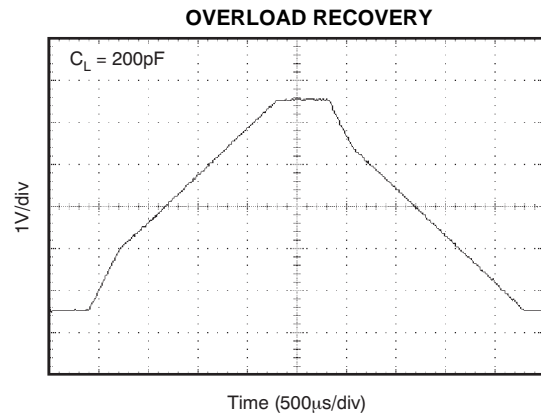

Figure 22.

APPLICATION INFORMATION

The OPA369 family of operational amplifiers minimizes power consumption and operates on supply voltages as low as 1.8V. Power-supply rejection ratio (PSRR), common-mode rejection ratio (CMRR), and open-loop gain (A_{OL}) typical values are in the range of 100dB or better.

When designing for ultralow power, choose system components carefully. To minimize current consumption, select large-value resistors. However, note that large resistors will react with stray capacitance in the circuit and the input capacitance of the operational amplifier. These parasitic RC combinations can affect the stability of the overall system. A feedback capacitor may be required to assure stability and limit overshoot or gain peaking.

Good layout practice and use of a 0.1 μ F bypass capacitor placed closely across the supply pins are mandatory.

OPERATING VOLTAGE

OPA369 series op amps are fully specified and tested from +1.8V to +5.5V. Parameters that vary significantly with supply voltage are shown in the [Typical Characteristic](#) curves.

INPUT COMMON-MODE VOLTAGE RANGE

The OPA369 family is designed to eliminate the input offset transition region typically present in most rail-to-rail complementary stage operational amplifiers, which allows the OPA369 family of amplifiers to provide superior common-mode performance over the entire input range.

The input common-mode voltage range of the OPA369 family typically extends to each supply rail. CMRR is specified from the negative rail to the positive rail. See [Figure 4](#) the *Normalized Offset Voltage vs Common-Mode Voltage*.

PROTECTING INPUTS FROM OVER-VOLTAGE

Input currents are typically 10pA. However, large inputs (greater than 500mV beyond the supply rails) can cause excessive current to flow in or out of the input pins. Therefore, in addition to keeping the input voltage between the supply rails, it is also important to limit the input current to less than 10mA. This limiting is easily accomplished with an input resistor, as shown in [Figure 23](#).

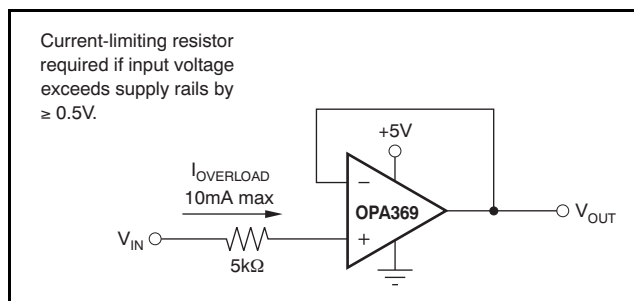

Figure 23. Input Current Protection for Voltages Exceeding the Supply Voltage

NOISE

Although micropower amplifiers frequently have high wideband noise, the OPA369 series offers excellent noise performance. The OPA369 has only 2.8 μ V_{PP} of 0.1Hz to 10Hz noise, and 80nV/ $\sqrt{\text{Hz}}$ of wideband noise. Resistors should be chosen carefully, because they can become the dominant source of noise.

CAPACITIVE LOAD AND STABILITY

Follower configurations with load capacitance in excess of approximately 50pF can produce extra overshoot and ringing in the output signal (see [Figure 19](#)). Increasing the gain enhances the ability of the amplifier to drive greater capacitive loads. In unity-gain configurations, capacitive load drive can be improved by inserting a small (10 Ω to 20 Ω) resistor, R_S , in series with the output, as shown in [Figure 24](#). This resistor significantly reduces ringing while maintaining dc performance for purely capacitive loads. However, if there is a resistive load in parallel with the capacitive load, a voltage divider is created, introducing a dc error at the output and slightly reducing the output swing. The error introduced is proportional to the ratio R_S/R_L , and is generally negligible.

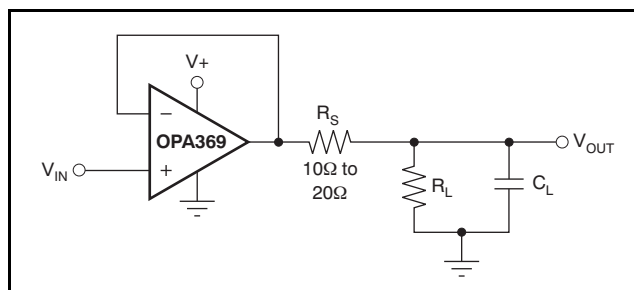

Figure 24. Series Resistor in Unity-Gain Buffer Configuration Improves Capacitive Load Drive

In unity-gain inverter configuration, phase margin can be reduced by the reaction between the capacitance at the op amp input and the gain setting resistors. Best performance is achieved by using smaller valued resistors. However, when larger valued resistors cannot be avoided, a small (4pF to 6pF) capacitor, C_{FB} , can be inserted in the feedback, as shown in Figure 25. This configuration significantly reduces overshoot by compensating the effect of capacitance, C_{IN} , which includes the amplifier input capacitance and printed circuit board (PCB) parasitic capacitance.

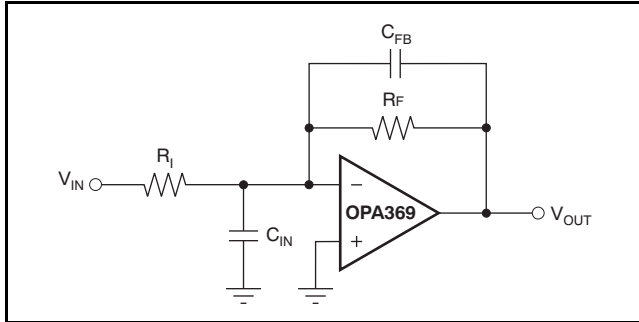

Figure 25. Improving Stability for Large R_F and R_{IN}

BATTERY MONITORING

The low operating voltage and quiescent current of the OPA369 series make it an excellent choice for battery monitoring applications, as shown in Figure 26. In this circuit, V_{STATUS} is high as long as the battery voltage remains above 2V. A low-power reference is used to set the trip point. Resistor values are selected as follows:

1. Selecting R_F : Select R_F such that the current through R_F is approximately 1000x larger than the maximum bias current over temperature:

$$\begin{aligned} R_F &= \frac{V_{REF}}{1000(I_{BMAX})} \\ &= \frac{1.2V}{1000(50pA)} \\ &= 24M\Omega \approx 20M\Omega \end{aligned} \quad (1)$$

2. Choose the hysteresis voltage, V_{HYST} . For battery-monitoring applications, 50mV is adequate.

3. Calculate R_1 as follows:

$$R_1 = R_F \left[\frac{V_{HYST}}{V_{BATT}} \right] = 20M\Omega \left[\frac{50mV}{2.4V} \right] = 420k\Omega \quad (2)$$

4. Select a threshold voltage for V_{IN} rising (V_{THRS}) = 2.0V

5. Calculate R_2 as follows:

$$\begin{aligned} R_2 &= \frac{1}{\left[\left(\frac{V_{THRS}}{V_{BATT}} \right) - \frac{1}{R_1} - \frac{1}{R_1} \right]} \\ &= \frac{1}{\left[\left(\frac{2V}{1.2V \times 420k\Omega} \right) - \frac{1}{420k\Omega} - \frac{1}{20M\Omega} \right]} \\ &= 650k\Omega \end{aligned} \quad (3)$$

6. Calculate R_{BIAS} : The minimum supply voltage for this circuit is 1.8V. The REF1112 has a current requirement of 1.2 μ A (max). Providing the REF1112 with 2 μ A of supply current assures proper operation. Therefore:

$$R_{BIAS} = \frac{V_{BATTMIN}}{I_{BIAS}} = \frac{1.8V}{2\mu A} = 0.9M\Omega \quad (4)$$

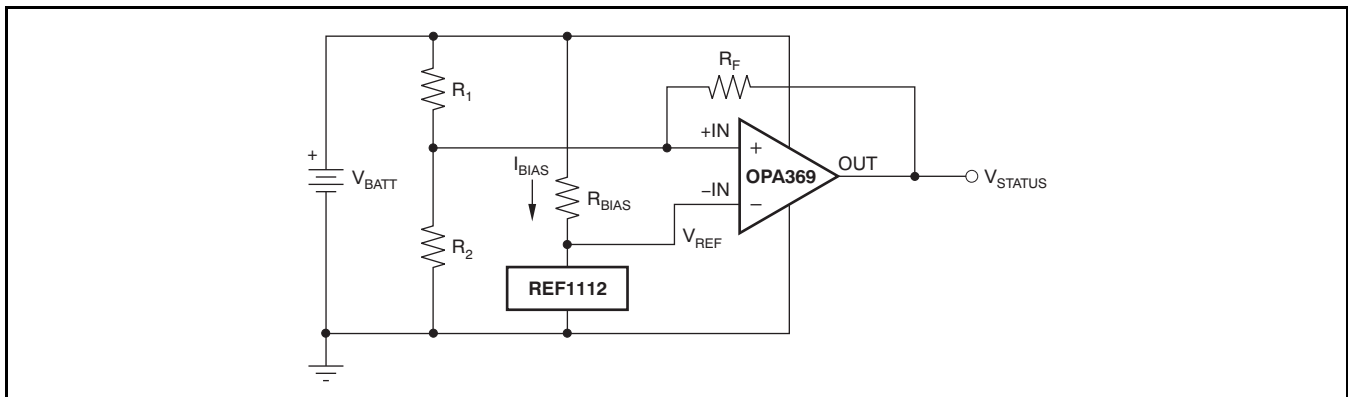

Figure 26. Battery Monitor

WINDOW COMPARATOR

Figure 27 shows the OPA2369 used as a window comparator. The threshold limits are set by V_H and V_L , with $V_H > V_L$. When $V_{IN} < V_H$, the output of A1 is low. When $V_{IN} > V_L$, the output of A2 is low. Therefore, both op amp outputs are at 0V as long as V_{IN} is between V_H and V_L . This configuration results in no current flowing through either diode, Q1 in cutoff, with the base voltage at 0V, and V_{OUT} forced high.

If V_{IN} falls below V_L , the output of A2 is high, current flows through D2, and V_{OUT} is low. Likewise, if V_{IN} rises above V_H , the output of A1 is high, current flows through D1, and V_{OUT} is low. The window comparator threshold voltages are set as follows:

$$V_H = \frac{R_2}{R_1 + R_2} \quad (5)$$

$$V_L = \frac{R_4}{R_3 + R_4} \quad (6)$$

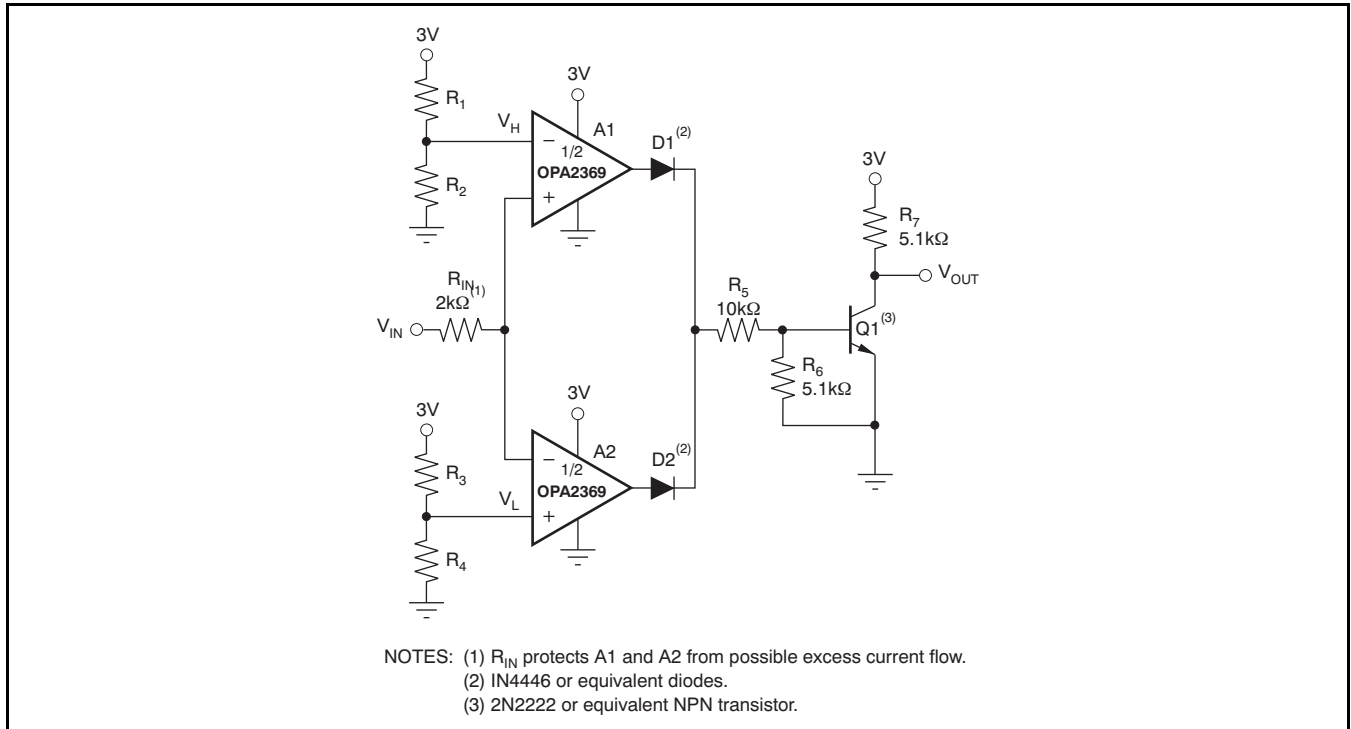

Figure 27. OPA2369 as a Window Comparator

ADDITIONAL APPLICATION EXAMPLES

Figure 28 through Figure 32 illustrate additional application examples.

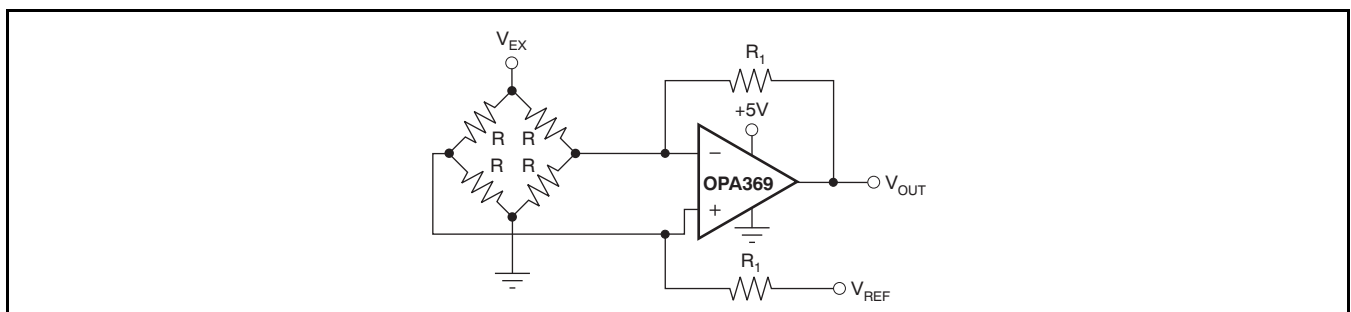

Figure 28. Single Op Amp Bridge Amplifier

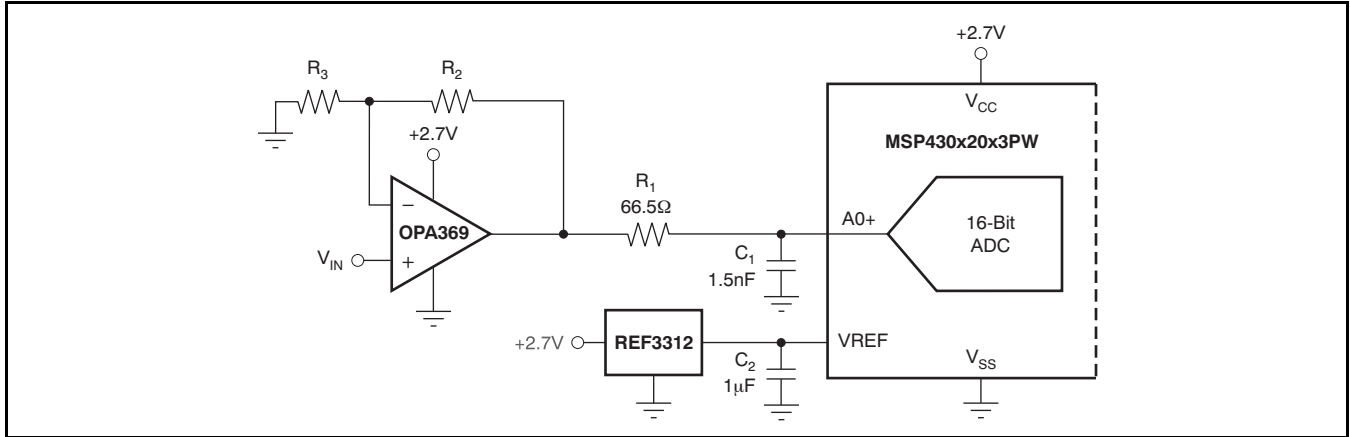

Figure 29. Unipolar Signal Chain Configuration

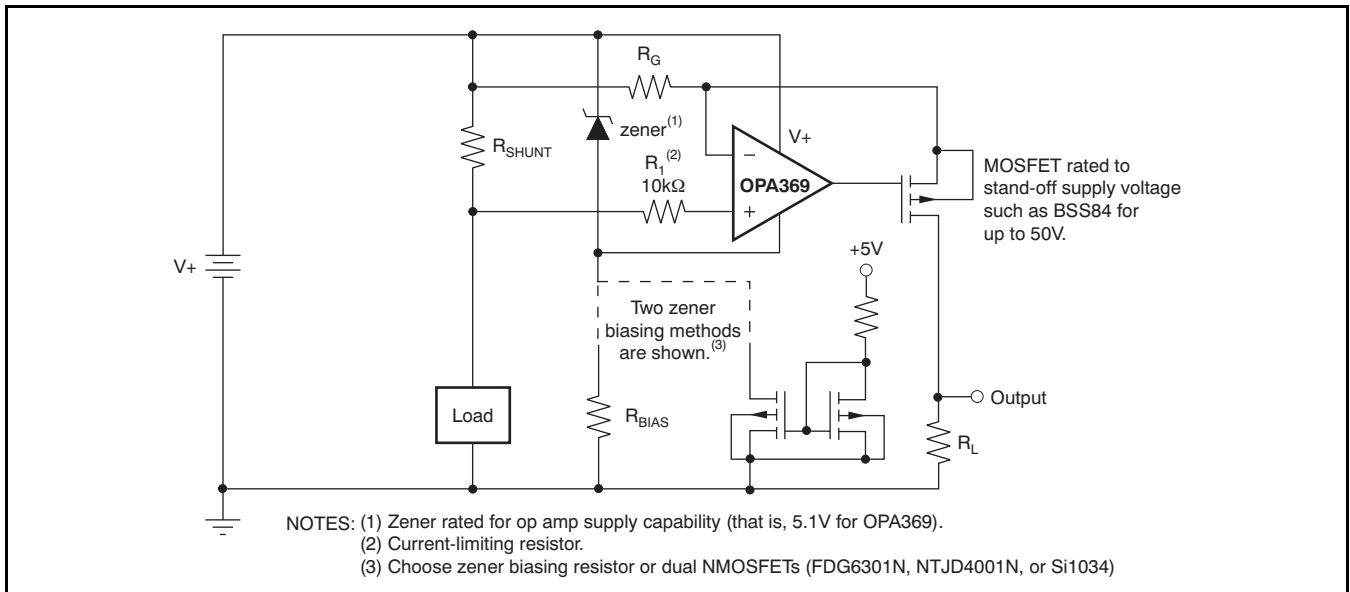

Figure 30. High-Side Current Monitor

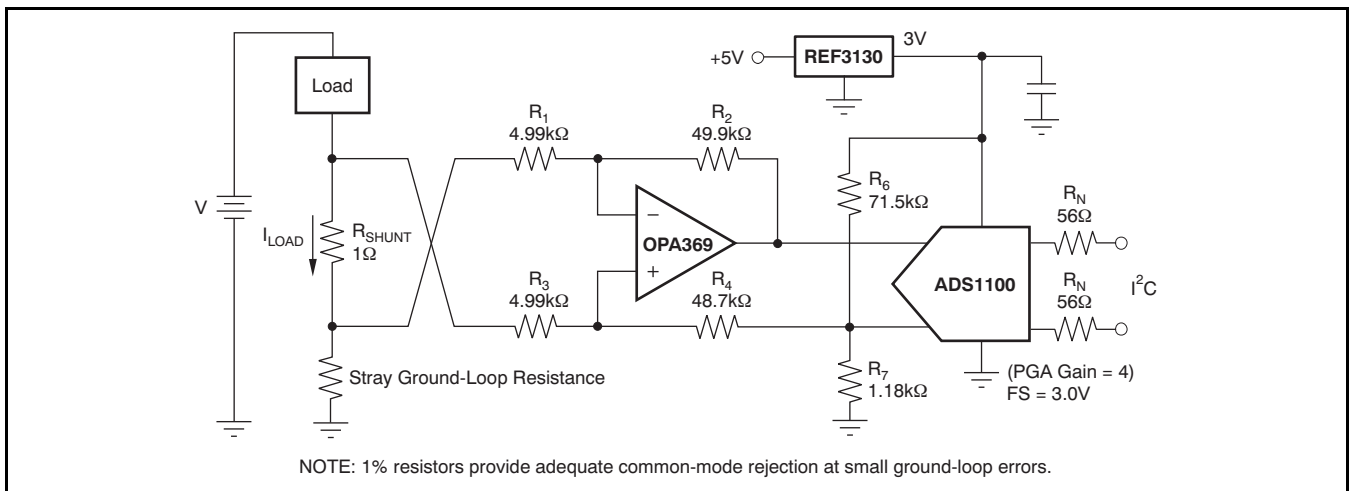

Figure 31. Low-Side Current Monitor

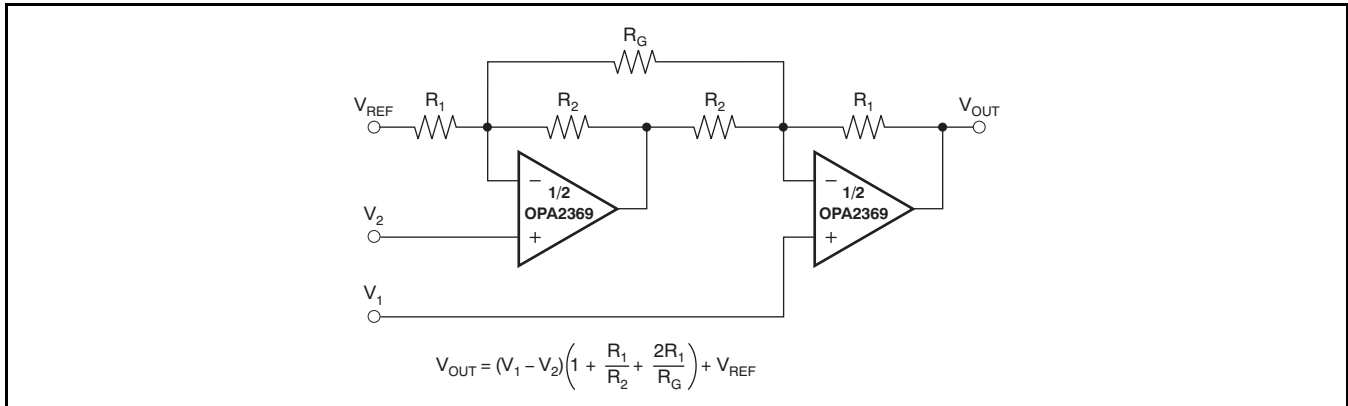

Figure 32. Two Op Amp Instrumentation Amplifier

PACKAGING INFORMATION

Orderable Device	Status ⁽¹⁾	Package Type	Package Drawing	Pins	Package Qty	Eco Plan ⁽²⁾	Lead/Ball Finish	MSL Peak Temp ⁽³⁾
OPA2369AIDCNR	ACTIVE	SOT-23	DCN	8	3000	Green (RoHS & no Sb/Br)	CU NIPDAU	Level-2-260C-1 YEAR
OPA2369AIDCNRG4	ACTIVE	SOT-23	DCN	8	3000	Green (RoHS & no Sb/Br)	CU NIPDAU	Level-2-260C-1 YEAR
OPA2369AIDCNT	ACTIVE	SOT-23	DCN	8	250	Green (RoHS & no Sb/Br)	CU NIPDAU	Level-2-260C-1 YEAR
OPA2369AIDCNTG4	ACTIVE	SOT-23	DCN	8	250	Green (RoHS & no Sb/Br)	CU NIPDAU	Level-2-260C-1 YEAR
OPA2369AIDGKR	ACTIVE	MSOP	DGK	8	2500	Green (RoHS & no Sb/Br)	CU NIPDAU	Level-2-260C-1 YEAR
OPA2369AIDGKRG4	ACTIVE	MSOP	DGK	8	2500	Green (RoHS & no Sb/Br)	CU NIPDAU	Level-2-260C-1 YEAR
OPA2369AIDGKT	ACTIVE	MSOP	DGK	8	250	Green (RoHS & no Sb/Br)	CU NIPDAU	Level-2-260C-1 YEAR
OPA2369AIDGKTG4	ACTIVE	MSOP	DGK	8	250	Green (RoHS & no Sb/Br)	CU NIPDAU	Level-2-260C-1 YEAR
OPA369AIDCKR	PREVIEW	SC70	DCK	5	3000	TBD	Call TI	Call TI
OPA369AIDCKT	PREVIEW	SC70	DCK	5	250	TBD	Call TI	Call TI

⁽¹⁾ The marketing status values are defined as follows:

ACTIVE: Product device recommended for new designs.

LIFEBUY: TI has announced that the device will be discontinued, and a lifetime-buy period is in effect.

NRND: Not recommended for new designs. Device is in production to support existing customers, but TI does not recommend using this part in a new design.

PREVIEW: Device has been announced but is not in production. Samples may or may not be available.

OBSOLETE: TI has discontinued the production of the device.

⁽²⁾ Eco Plan - The planned eco-friendly classification: Pb-Free (RoHS), Pb-Free (RoHS Exempt), or Green (RoHS & no Sb/Br) - please check <http://www.ti.com/productcontent> for the latest availability information and additional product content details.

TBD: The Pb-Free/Green conversion plan has not been defined.

Pb-Free (RoHS): TI's terms "Lead-Free" or "Pb-Free" mean semiconductor products that are compatible with the current RoHS requirements for all 6 substances, including the requirement that lead not exceed 0.1% by weight in homogeneous materials. Where designed to be soldered at high temperatures, TI Pb-Free products are suitable for use in specified lead-free processes.

Pb-Free (RoHS Exempt): This component has a RoHS exemption for either 1) lead-based flip-chip solder bumps used between the die and package, or 2) lead-based die adhesive used between the die and leadframe. The component is otherwise considered Pb-Free (RoHS compatible) as defined above.

Green (RoHS & no Sb/Br): TI defines "Green" to mean Pb-Free (RoHS compatible), and free of Bromine (Br) and Antimony (Sb) based flame retardants (Br or Sb do not exceed 0.1% by weight in homogeneous material)

⁽³⁾ MSL, Peak Temp. -- The Moisture Sensitivity Level rating according to the JEDEC industry standard classifications, and peak solder temperature.

Important Information and Disclaimer: The information provided on this page represents TI's knowledge and belief as of the date that it is provided. TI bases its knowledge and belief on information provided by third parties, and makes no representation or warranty as to the accuracy of such information. Efforts are underway to better integrate information from third parties. TI has taken and continues to take reasonable steps to provide representative and accurate information but may not have conducted destructive testing or chemical analysis on incoming materials and chemicals. TI and TI suppliers consider certain information to be proprietary, and thus CAS numbers and other limited information may not be available for release.

In no event shall TI's liability arising out of such information exceed the total purchase price of the TI part(s) at issue in this document sold by TI to Customer on an annual basis.

TAPE AND REEL BOX INFORMATION

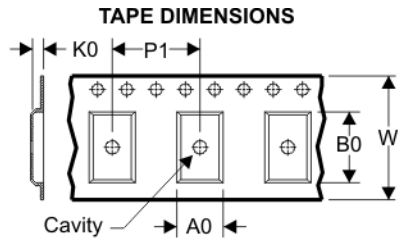
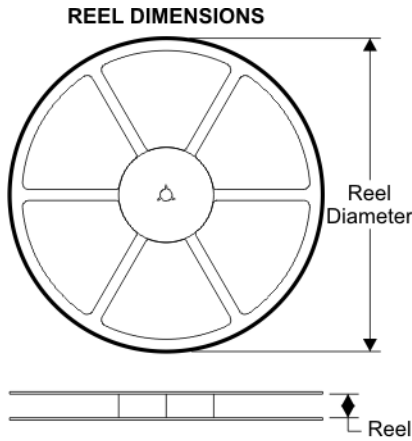

A0	Dimension designed to accommodate the component width
B0	Dimension designed to accommodate the component length
K0	Dimension designed to accommodate the component thickness
W	Overall width of the carrier tape
P1	Pitch between successive cavity centers

QUADRANT ASSIGNMENTS FOR PIN 1 ORIENTATION IN TAPE

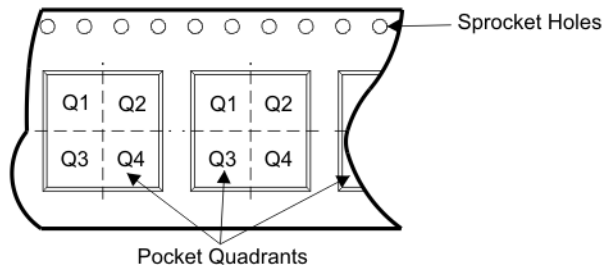

Device	Package	Pins	Site	Reel Diameter (mm)	Reel Width (mm)	A0 (mm)	B0 (mm)	K0 (mm)	P1 (mm)	W (mm)	Pin1 Quadrant
OPA2369AIDCNR	DCN	8	SITE 48	179	8	3.2	3.2	1.4	4	8	Q3
OPA2369AIDCNT	DCN	8	SITE 48	179	8	3.2	3.2	1.4	4	8	Q3

TAPE AND REEL BOX DIMENSIONS



Device	Package	Pins	Site	Length (mm)	Width (mm)	Height (mm)
OPA2369AIDCNR	DCN	8	SITE 48	195.0	200.0	45.0
OPA2369AIDCNT	DCN	8	SITE 48	195.0	200.0	45.0

DCK (R-PDSO-G5)

PLASTIC SMALL-OUTLINE PACKAGE

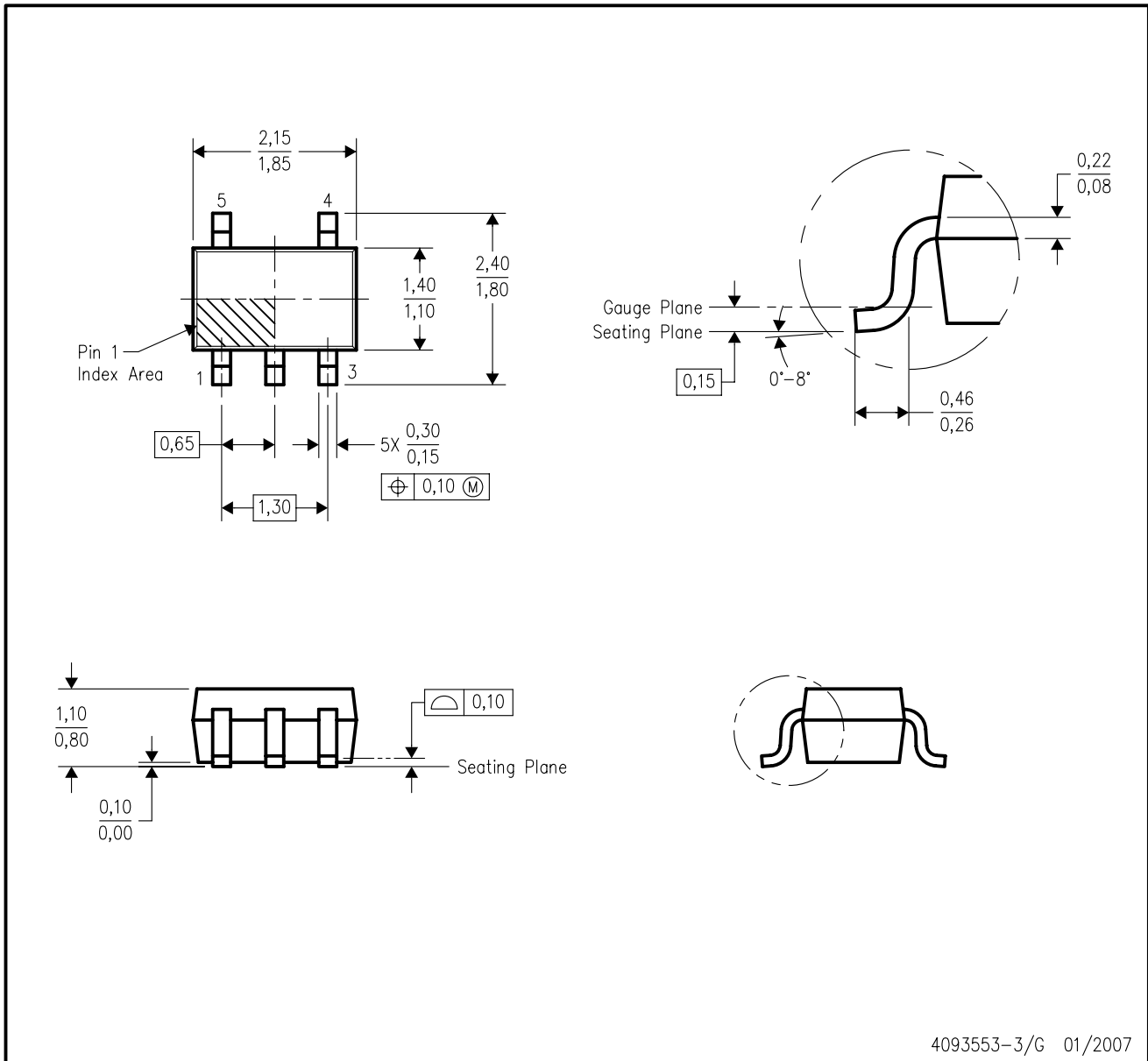

- NOTES:
- A. All linear dimensions are in millimeters.
 - B. This drawing is subject to change without notice.
 - C. Body dimensions do not include mold flash or protrusion. Mold flash and protrusion shall not exceed 0.15 per side.
 - D. Falls within JEDEC MO-203 variation AA.

DGK (S-PDSO-G8)

PLASTIC SMALL-OUTLINE PACKAGE

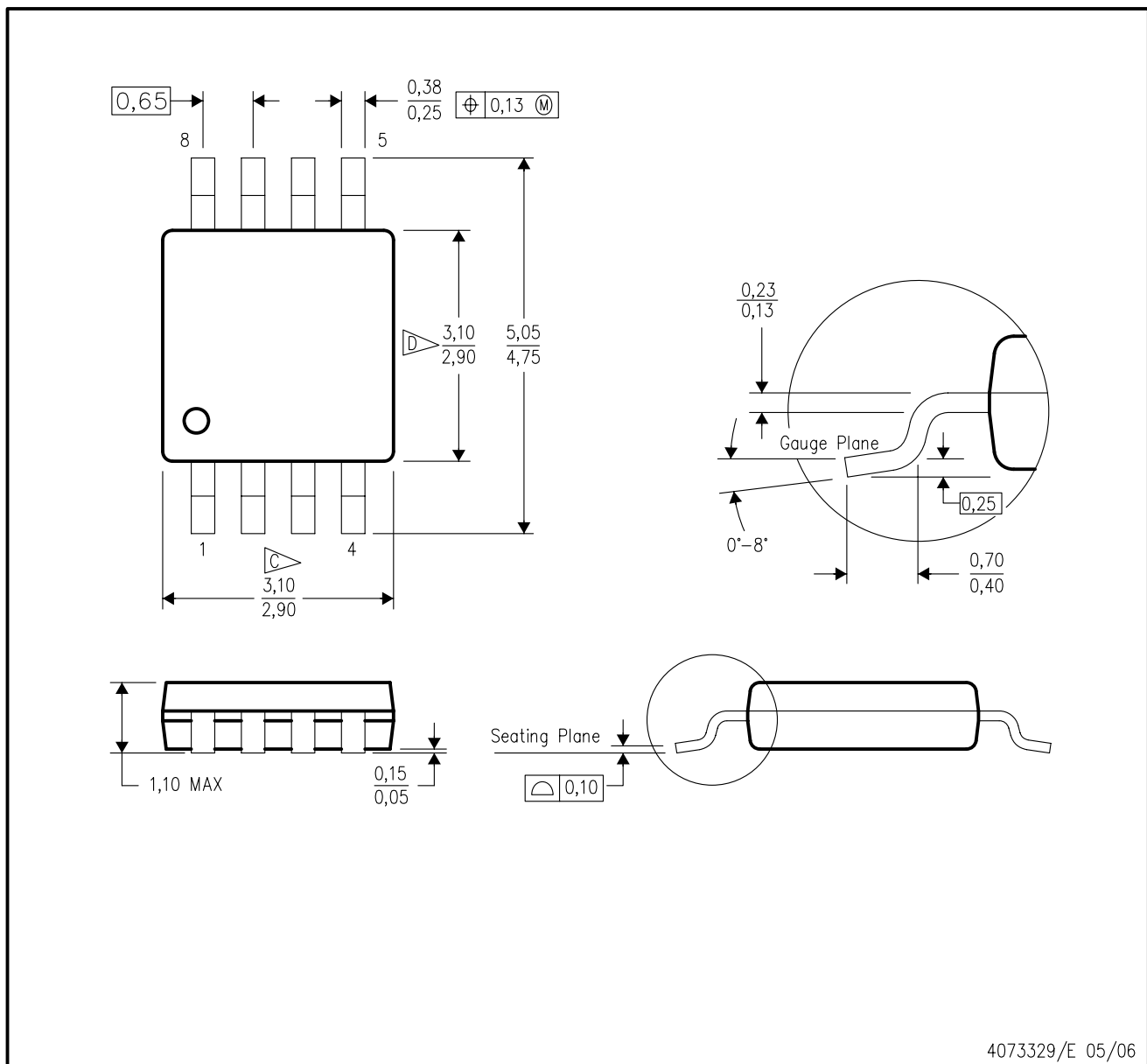

- NOTES:
- A. All linear dimensions are in millimeters.
 - B. This drawing is subject to change without notice.
 - C. Body length does not include mold flash, protrusions, or gate burrs. Mold flash, protrusions, or gate burrs shall not exceed 0.15 per end.
 - D. Body width does not include interlead flash. Interlead flash shall not exceed 0.50 per side.
 - E. Falls within JEDEC MO-187 variation AA, except interlead flash.

DCN (R-PDSO-G8)

PLASTIC SMALL-OUTLINE PACKAGE (DIE DOWN)

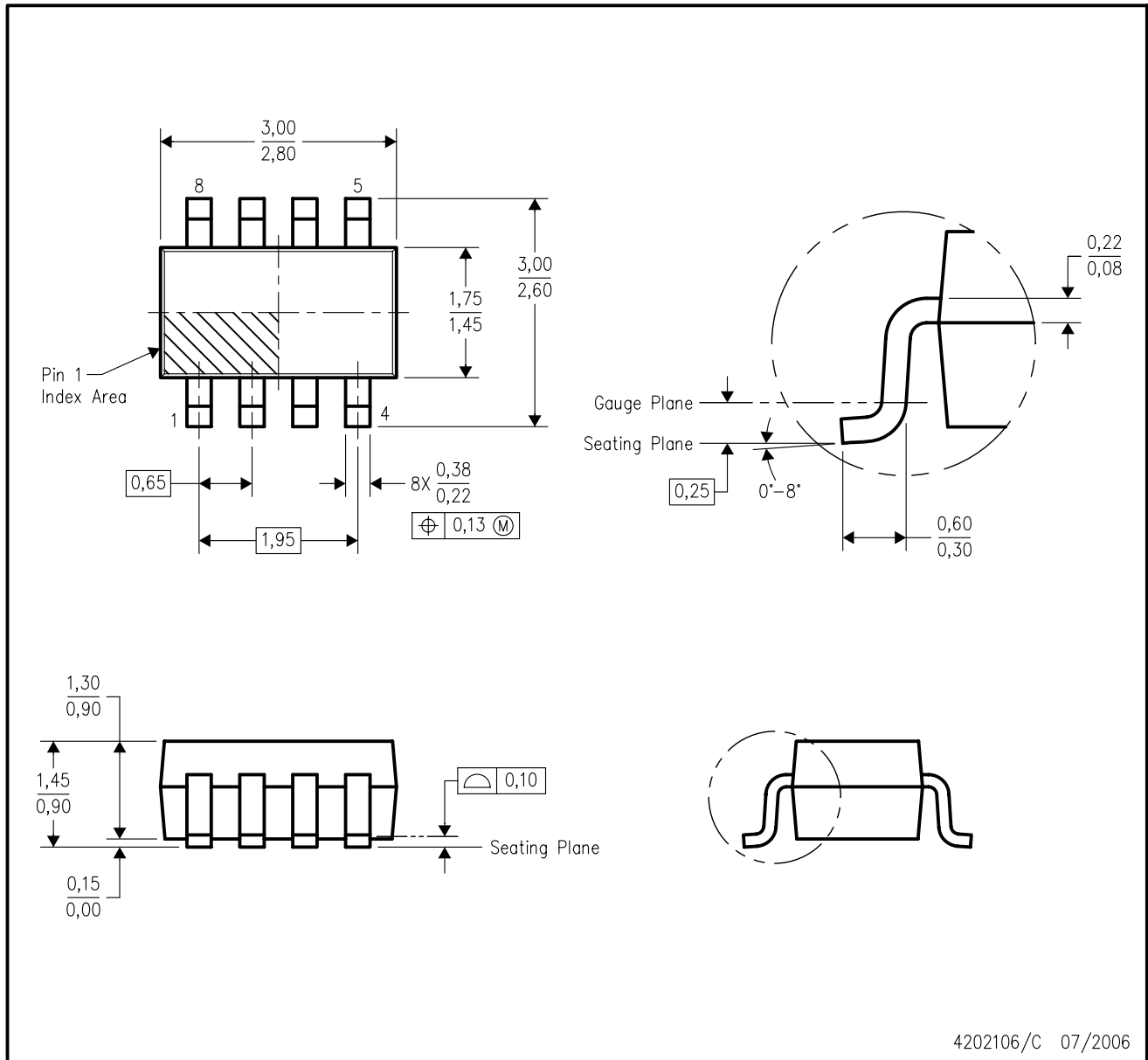

- NOTES:
- All linear dimensions are in millimeters.
 - This drawing is subject to change without notice.
 - Package outline exclusive of mold flash, metal burr & dambar protrusion/intrusion.
 - Package outline inclusive of solder plating.
 - A visual index feature must be located within the Pin 1 index area.
 - Falls within JEDEC MO-178 Variation BA.

IMPORTANT NOTICE

Texas Instruments Incorporated and its subsidiaries (TI) reserve the right to make corrections, modifications, enhancements, improvements, and other changes to its products and services at any time and to discontinue any product or service without notice. Customers should obtain the latest relevant information before placing orders and should verify that such information is current and complete. All products are sold subject to TI's terms and conditions of sale supplied at the time of order acknowledgment.

TI warrants performance of its hardware products to the specifications applicable at the time of sale in accordance with TI's standard warranty. Testing and other quality control techniques are used to the extent TI deems necessary to support this warranty. Except where mandated by government requirements, testing of all parameters of each product is not necessarily performed.

TI assumes no liability for applications assistance or customer product design. Customers are responsible for their products and applications using TI components. To minimize the risks associated with customer products and applications, customers should provide adequate design and operating safeguards.

TI does not warrant or represent that any license, either express or implied, is granted under any TI patent right, copyright, mask work right, or other TI intellectual property right relating to any combination, machine, or process in which TI products or services are used. Information published by TI regarding third-party products or services does not constitute a license from TI to use such products or services or a warranty or endorsement thereof. Use of such information may require a license from a third party under the patents or other intellectual property of the third party, or a license from TI under the patents or other intellectual property of TI.

Reproduction of TI information in TI data books or data sheets is permissible only if reproduction is without alteration and is accompanied by all associated warranties, conditions, limitations, and notices. Reproduction of this information with alteration is an unfair and deceptive business practice. TI is not responsible or liable for such altered documentation. Information of third parties may be subject to additional restrictions.

Resale of TI products or services with statements different from or beyond the parameters stated by TI for that product or service voids all express and any implied warranties for the associated TI product or service and is an unfair and deceptive business practice. TI is not responsible or liable for any such statements.

TI products are not authorized for use in safety-critical applications (such as life support) where a failure of the TI product would reasonably be expected to cause severe personal injury or death, unless officers of the parties have executed an agreement specifically governing such use. Buyers represent that they have all necessary expertise in the safety and regulatory ramifications of their applications, and acknowledge and agree that they are solely responsible for all legal, regulatory and safety-related requirements concerning their products and any use of TI products in such safety-critical applications, notwithstanding any applications-related information or support that may be provided by TI. Further, Buyers must fully indemnify TI and its representatives against any damages arising out of the use of TI products in such safety-critical applications.

TI products are neither designed nor intended for use in military/aerospace applications or environments unless the TI products are specifically designated by TI as military-grade or "enhanced plastic." Only products designated by TI as military-grade meet military specifications. Buyers acknowledge and agree that any such use of TI products which TI has not designated as military-grade is solely at the Buyer's risk, and that they are solely responsible for compliance with all legal and regulatory requirements in connection with such use.

TI products are neither designed nor intended for use in automotive applications or environments unless the specific TI products are designated by TI as compliant with ISO/TS 16949 requirements. Buyers acknowledge and agree that, if they use any non-designated products in automotive applications, TI will not be responsible for any failure to meet such requirements.

Following are URLs where you can obtain information on other Texas Instruments products and application solutions:

Products		Applications	
Amplifiers	amplifier.ti.com	Audio	www.ti.com/audio
Data Converters	dataconverter.ti.com	Automotive	www.ti.com/automotive
DSP	dsp.ti.com	Broadband	www.ti.com/broadband
Interface	interface.ti.com	Digital Control	www.ti.com/digitalcontrol
Logic	logic.ti.com	Military	www.ti.com/military
Power Mgmt	power.ti.com	Optical Networking	www.ti.com/opticalnetwork
Microcontrollers	microcontroller.ti.com	Security	www.ti.com/security
RFID	www.ti-rfid.com	Telephony	www.ti.com/telephony
Low Power Wireless	www.ti.com/lpw	Video & Imaging	www.ti.com/video
		Wireless	www.ti.com/wireless

Mailing Address: Texas Instruments, Post Office Box 655303, Dallas, Texas 75265
Copyright © 2007, Texas Instruments Incorporated