



Precision, Low Power, 18MHz Transimpedance Amplifier

FEATURES

- OVER 250kHz TRANSIMPEDANCE BANDWIDTH
- DYNAMIC RANGE: 5 Decades
- EXCELLENT LONG-TERM STABILITY
- LOW VOLTAGE NOISE: $10\text{nV}/\sqrt{\text{Hz}}$
- BIAS CURRENT: 3pA
- OFFSET VOLTAGE: $25\mu\text{V}$ (max)
- OFFSET DRIFT: $0.1\mu\text{V}/^\circ\text{C}$ (max)
- GAIN BANDWIDTH: 18MHz
- QUIESCENT CURRENT: $800\mu\text{A}$
- FAST OVERLOAD RECOVERY
- SUPPLY RANGE: 2.7V to 5.5V
- SINGLE AND DUAL VERSIONS
- *Micro*PACKAGE: DFN-8, MSOP-8

APPLICATIONS

- PRECISION I/V CONVERSION
- PHOTODIODE MONITORING
- OPTICAL AMPLIFIERS
- CAT-SCANNER FRONT-END
- PHOTO LAB EQUIPMENT

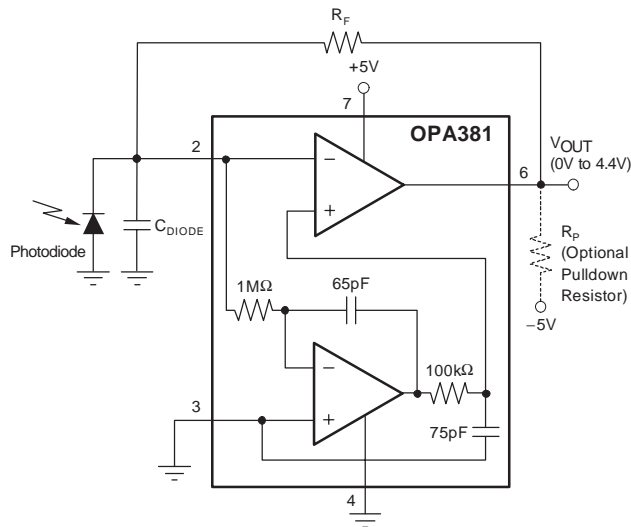

DESCRIPTION

The OPA381 family of transimpedance amplifiers provides 18MHz of Gain Bandwidth (GBW), with extremely high precision, excellent long-term stability, and very low 1/f noise. The OPA381 features an offset voltage of $25\mu\text{V}$ (max), offset drift of $0.1\mu\text{V}/^\circ\text{C}$ (max), and bias current of 3pA. The OPA381 far exceeds the offset, drift, and noise performance that conventional JFET op amps provide.

The signal bandwidth of a transimpedance amplifier depends largely on the GBW of the amplifier and the parasitic capacitance of the photodiode, as well as the feedback resistor. The 18MHz GBW of the OPA381 enables a transimpedance bandwidth of $> 250\text{kHz}$ in most configurations. The OPA381 is ideally suited for fast control loops for power level measurement on an optical fiber.

As a result of the high precision and low-noise characteristics of the OPA381, a dynamic range of 5 decades can be achieved. This capability allows the measurement of signal currents on the order of 10nA, and up to 1mA in a single I/V conversion stage. In contrast to logarithmic amplifiers, the OPA381 provides very wide bandwidth throughout the full dynamic range. By using an external pull-down resistor to -5V , the output voltage range can be extended to include 0V.

The OPA381 and OPA2381 are both available in MSOP-8 and DFN-8 (3mm x 3mm) packages. They are specified from -40°C to $+125^\circ\text{C}$.

OPA381 RELATED DEVICES

PRODUCT	FEATURES
OPA380	90MHz GBW, 2.7V to 5.5V Supply Transimpedance Amplifier
OPA132	16MHz GBW, Precision FET Op Amp $\pm 15\text{V}$
OPA300	150MHz GBW, Low-Noise, 2.7V to 5.5V Supply
OPA335	$10\mu\text{V}$ V_{OS} , Zero-Drift, 2.5V to 5V Supply
OPA350	$500\mu\text{V}$ V_{OS} , 38MHz, 2.5V to 5V Supply
OPA354	100MHz GBW CMOS, RRIO, 2.5V to 5V Supply
OPA355	200MHz GBW CMOS, 2.5V to 5V Supply
OPA656/7	230MHz, Precision FET, $\pm 5\text{V}$



Please be aware that an important notice concerning availability, standard warranty, and use in critical applications of Texas Instruments semiconductor products and disclaimers thereto appears at the end of this data sheet.

All trademarks are the property of their respective owners.

ABSOLUTE MAXIMUM RATINGS(1)

Voltage Supply	+7V
Signal Input Terminals(2), Voltage	(V-) -0.5V to (V+) + 0.5V
Current	±10mA
Short-Circuit Current(3)	Continuous
Operating Temperature Range	-40°C to +125°C
Storage Temperature Range	-65°C to +150°C
Junction Temperature	+150°C
Lead Temperature (soldering, 10s)	+300°C
OPA381 ESD Rating (Human Body Model)	2000V
OPA2381 ESD Rating (Human Body Model)	1500V

- (1) Stresses above these ratings may cause permanent damage. Exposure to absolute maximum conditions for extended periods may degrade device reliability. These are stress ratings only, and functional operation of the device at these or any other conditions beyond those specified is not implied.
- (2) Input terminals are diode clamped to the power-supply rails. Input signals that can swing more than 0.5V beyond the supply rails should be current limited to 10mA or less.
- (3) Short-circuit to ground; one amplifier per package.

ELECTROSTATIC DISCHARGE SENSITIVITY



This integrated circuit can be damaged by ESD. Texas Instruments recommends that all integrated circuits be handled with appropriate precautions. Failure to observe proper handling and installation procedures can cause damage.

ESD damage can range from subtle performance degradation to complete device failure. Precision integrated circuits may be more susceptible to damage because very small parametric changes could cause the device not to meet its published specifications.

PACKAGE/ORDERING INFORMATION(1)

PRODUCT	PACKAGE-LEAD	PACKAGE DESIGNATOR	SPECIFIED TEMPERATURE RANGE	PACKAGE MARKING	ORDERING NUMBER	TRANSPORT MEDIA, QUANTITY
OPA381	MSOP-8	DGK	-40°C to +125°C	A64	OPA381AIDGKT	Tape and Reel, 250
					OPA381AIDGKR	Tape and Reel, 2500
OPA381	DFN-8	DRB	-40°C to +125°C	A65	OPA381AIDRBT	Tape and Reel, 250
					OPA381AIDRBR	Tape and Reel, 3000
OPA2381	MSOP-8	DGK	-40°C to +125°C	A62	OPA2381AIDGKT	Tape and Reel, 250
					OPA2381AIDGKR	Tape and Reel, 2500
OPA2381	DFN-8	DRB	-40°C to +125°C	A63	OPA2381AIDRBT	Tape and Reel, 250
					OPA2381AIDRBR	Tape and Reel, 3000

(1) For the most current package and ordering information, see the Package Option Addendum located at the end of this data sheet.

PIN ASSIGNMENTS

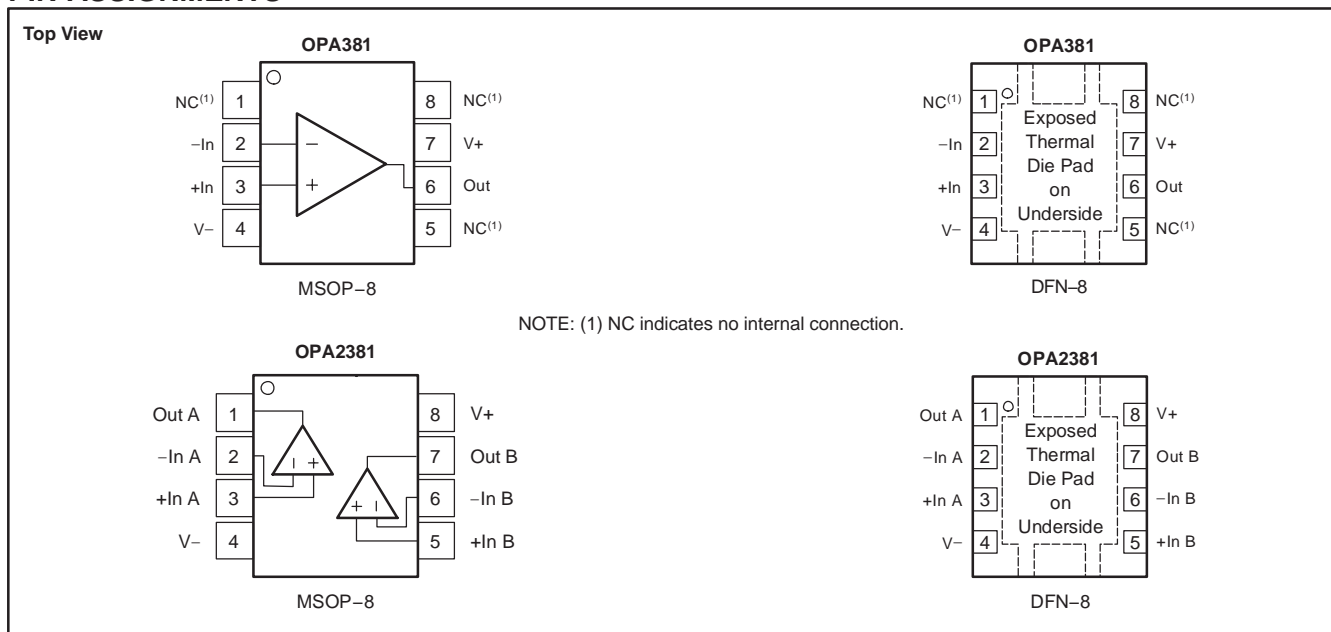

ELECTRICAL CHARACTERISTICS: $V_S = +2.7V$ to $+5.5V$

Boldface limits apply over the temperature range, $T_A = -40^\circ C$ to $+125^\circ C$.

All specifications at $T_A = +25^\circ C$, $R_L = 10k\Omega$ connected to $V_S/2$, and $V_{OUT} = V_S/2$, unless otherwise noted.

PARAMETER	CONDITION	OPA381			UNITS
		MIN	TYP	MAX	
OFFSET VOLTAGE					
Input Offset Voltage	$V_S = +5V, V_{CM} = 0V$		7	25	μV
Drift			0.03	0.1	$\mu V/^\circ C$
vs Power Supply	$V_S = +2.7V$ to $+5.5V, V_{CM} = 0V$		3.5	20	$\mu V/V$
Over Temperature	$V_S = +2.7V$ to $+5.5V, V_{CM} = 0V$			20	$\mu V/V$
Long-Term Stability(1)			See Note (1)		
Channel Separation, dc			1		$\mu V/V$
INPUT BIAS CURRENT					
Input Bias Current	$V_{CM} = V_S/2$		3	± 50	pA
Over Temperature			See Typical Characteristics		
Input Offset Current	$V_{CM} = V_S/2$		6	± 100	pA
NOISE					
Input Voltage Noise, $f = 0.1Hz$ to $10Hz$	$V_S = +5V, V_{CM} = 0V$		3		μV_{PP}
Input Voltage Noise Density, $f = 10kHz$	$V_S = +5V, V_{CM} = 0V$		70		nV/\sqrt{Hz}
Input Voltage Noise Density, $f > 1MHz$	$V_S = +5V, V_{CM} = 0V$		10		nV/\sqrt{Hz}
Input Current Noise Density, $f = 10kHz$	$V_S = +5V, V_{CM} = 0V$		20		fA/\sqrt{Hz}
INPUT VOLTAGE RANGE					
Common-Mode Voltage Range		V-		$(V+) - 1.8V$	V
Common-Mode Rejection Ratio	$V_S = +5V, (V-) < V_{CM} < (V+) - 1.8V$	95	110		dB
INPUT IMPEDANCE					
Differential Capacitance			1		pF
Common-Mode Resistance and Capacitance			$10^{13} 2.5$		ΩpF
OPEN-LOOP GAIN					
Open-Loop Voltage Gain	$0.05V < V_O < (V+) - 0.6V, V_{CM} = V_S/2, V_S = 5V$	110	135		dB
	$0V < V_O < (V+) - 0.6V, V_{CM} = 0V, R_P = 10k\Omega$ to $-5V^{(2)}, V_S = 5V$	106	135		dB
FREQUENCY RESPONSE					
Gain-Bandwidth Product	$G = +1$		18		MHz
Slew Rate	$V_S = +5V, 4V$ Step, $G = +1$, OPA381		12		$V/\mu s$
Settling Time, 0.0015%(3)	$V_S = +5V, 4V$ Step, $G = +1$, OPA381		7		μs
Settling Time, 0.003%(3)	$V_S = +5V, 4V$ Step, $G = +1$, OPA2381		7		μs
Overload Recovery Time(4), (5)	$V_{IN} \cdot G = > V_S$		200		ns
OUTPUT					
Voltage Output Swing from Positive Rail	$R_L = 10k\Omega$		400	600	mV
Voltage Output Swing from Negative Rail	$R_L = 10k\Omega$		30	50	mV
Voltage Output Swing from Positive Rail	$R_P = 10k\Omega$ to $-5V^{(2)}$		400	600	mV
Voltage Output Swing from Negative Rail	$R_P = 10k\Omega$ to $-5V^{(2)}$		-20	0	mV
Output Current			10		mA
Short-Circuit Current			20		mA
Capacitive Load Drive			See Typical Characteristics		
Open-Loop Output Impedance	$F = 1MHz, I_O = 0$		250		Ω
POWER SUPPLY					
Specified Voltage Range		2.7		5.5	V
Quiescent Current (per amplifier)	$I_O = 0A$		0.8	1	mA
Over Temperature				1.1	mA
TEMPERATURE RANGE					
Specified and Operating Range		-40		+125	$^\circ C$
Storage Range		-65		+150	$^\circ C$
Thermal Resistance	θ_{JA}				
MSOP-8			150		$^\circ C/W$
DFN-8			65		$^\circ C/W$

- (1) High temperature operating life characterization of zero-drift op amps applying the techniques used in the OPA381 have repeatedly demonstrated randomly distributed variation approximately equal to measurement repeatability of $1\mu V$. This consistency gives confidence in the stability and repeatability of these zero-drift techniques.
- (2) Tested with output connected only to R_P , a pulldown resistor connected between V_{OUT} and $-5V$, as shown in Figure 3. See also **Applications** section, *Achieving Output Swing to Negative Rail*.
- (3) Transimpedance frequency of 250kHz.
- (4) Time required to return to linear operation.
- (5) From positive rail.

TYPICAL CHARACTERISTICS: $V_S = +2.7V$ to $+5.5V$

All specifications at $T_A = +25^\circ C$, $R_L = 10k\Omega$ connected to $V_S/2$, and $V_{OUT} = V_S/2$, unless otherwise noted.

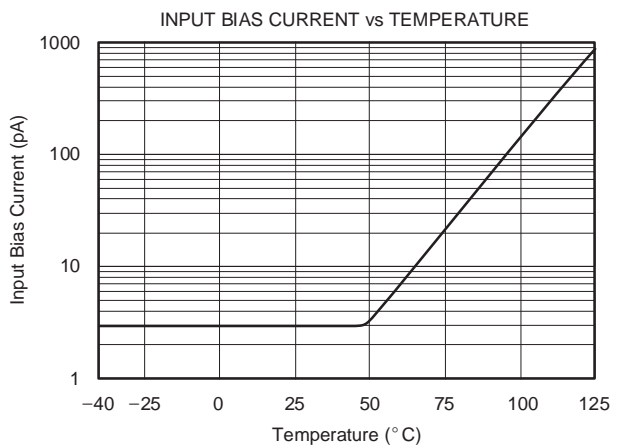
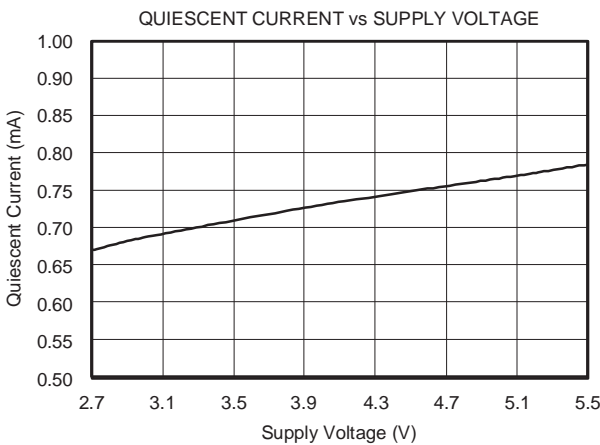
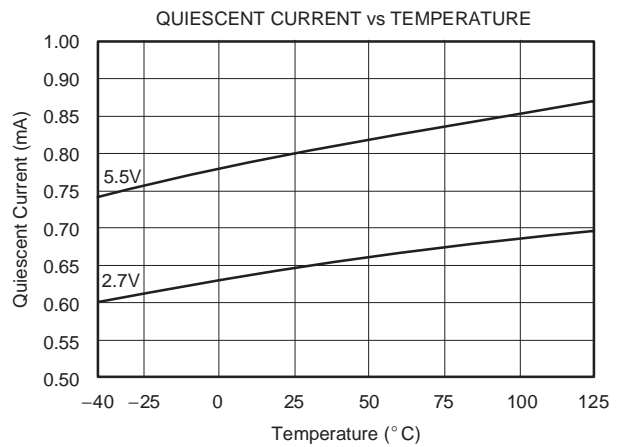
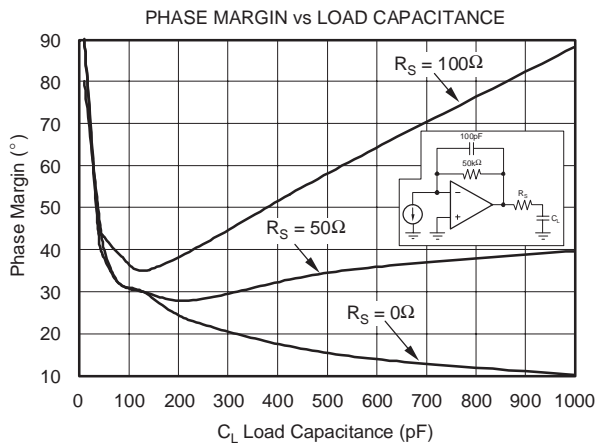
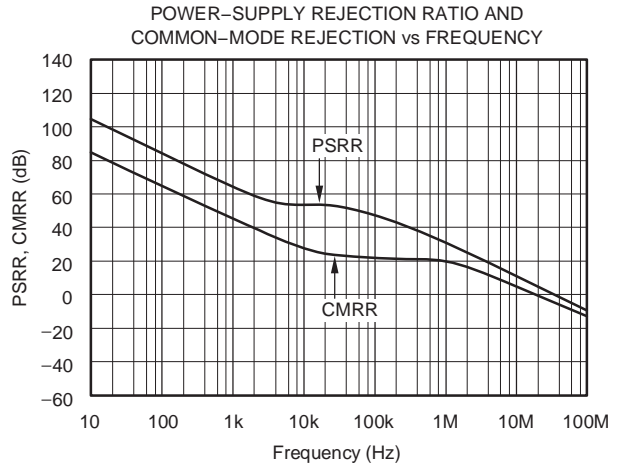
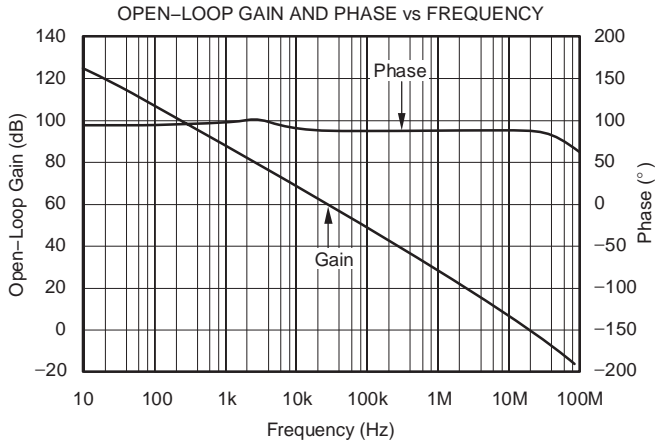

TYPICAL CHARACTERISTICS: $V_S = +2.7V$ to $+5.5V$ (continued)

All specifications at $T_A = +25^\circ C$, $R_L = 10k\Omega$ connected to $V_S/2$, and $V_{OUT} = V_S/2$, unless otherwise noted.

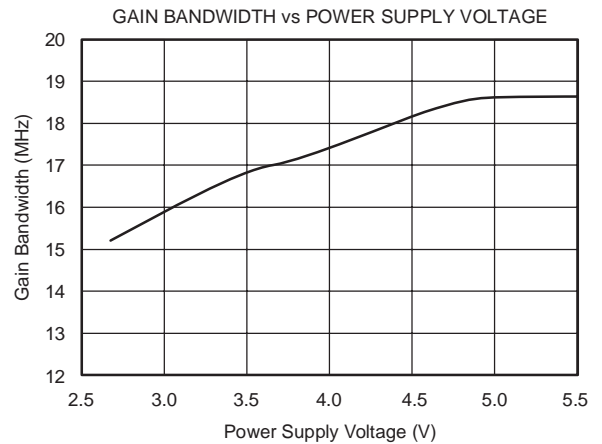
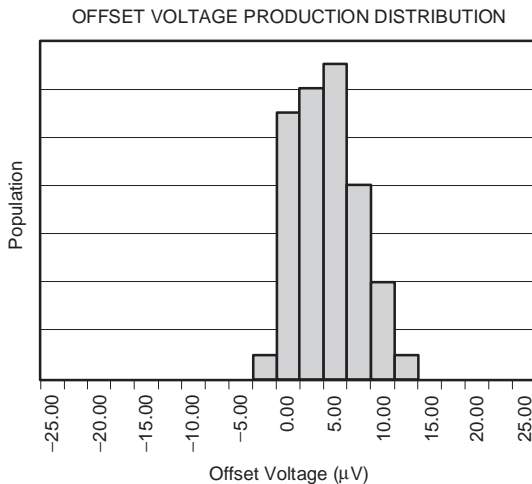
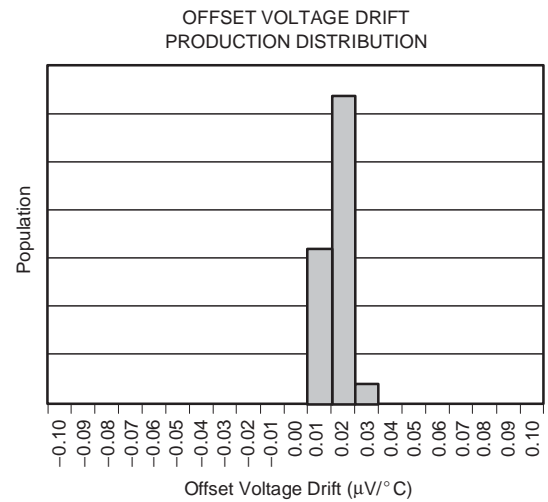
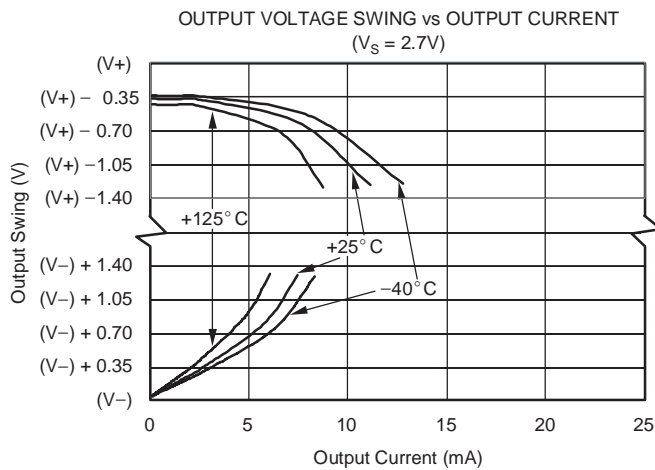
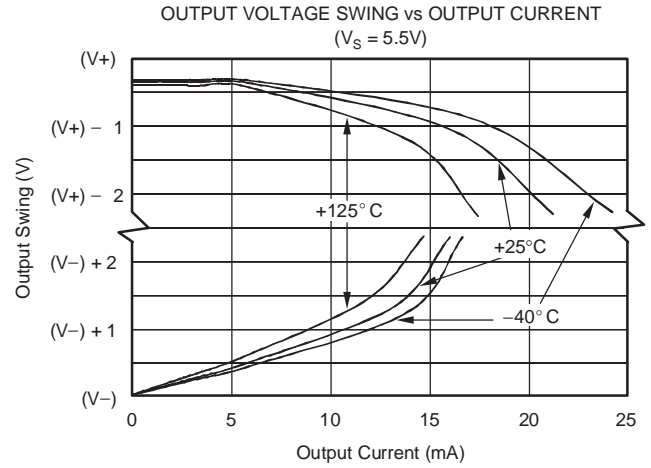
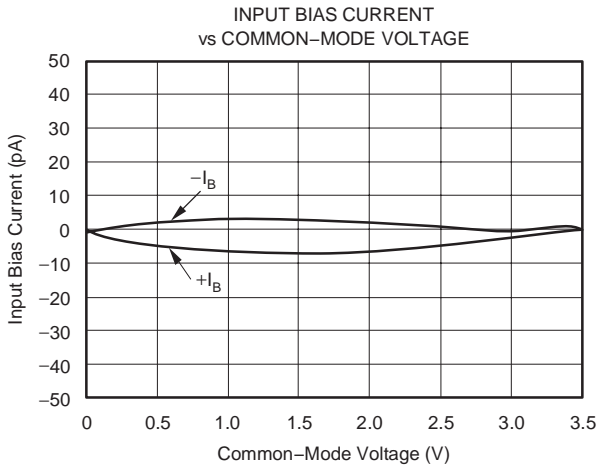

TYPICAL CHARACTERISTICS: $V_S = +2.7V$ to $+5.5V$ (continued)

All specifications at $T_A = +25^\circ C$, $R_L = 10k\Omega$ connected to $V_S/2$, and $V_{OUT} = V_S/2$, unless otherwise noted.

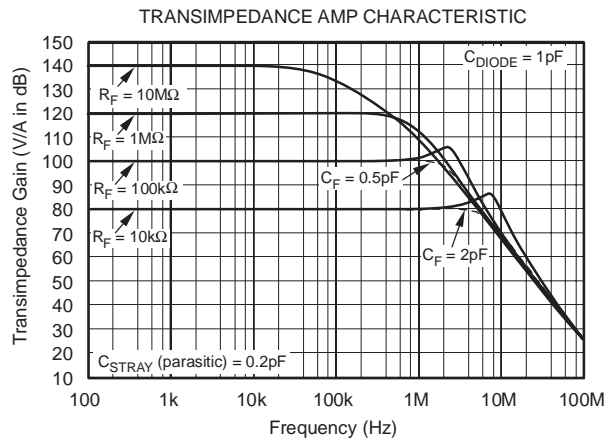
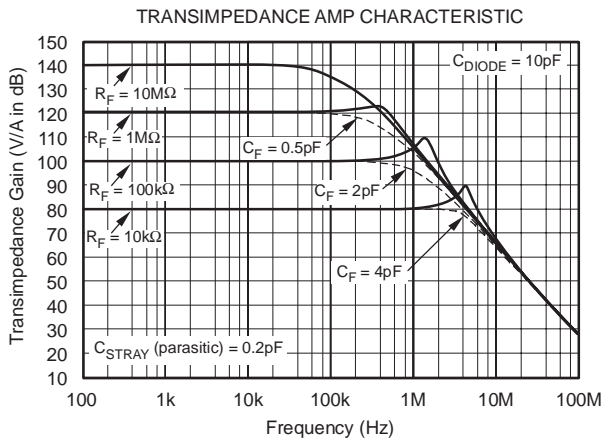
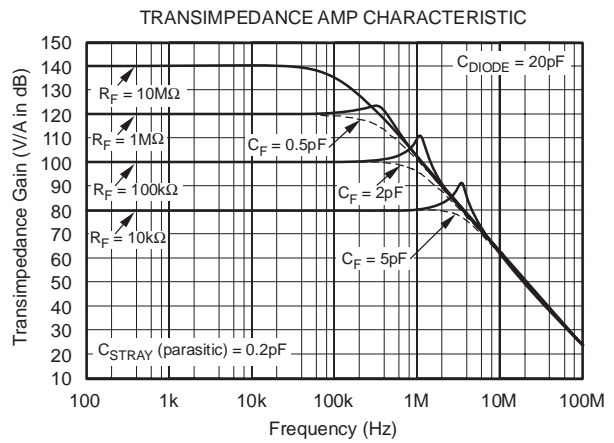
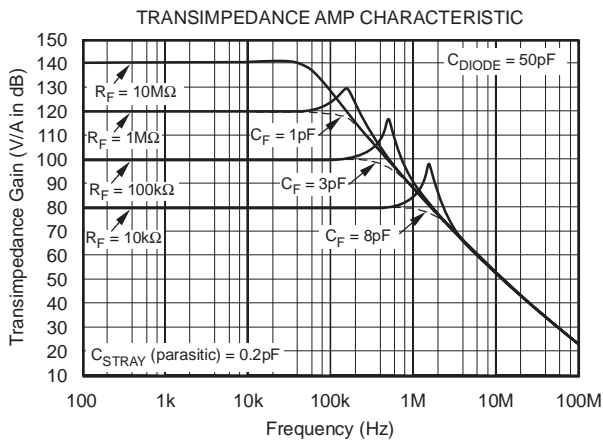
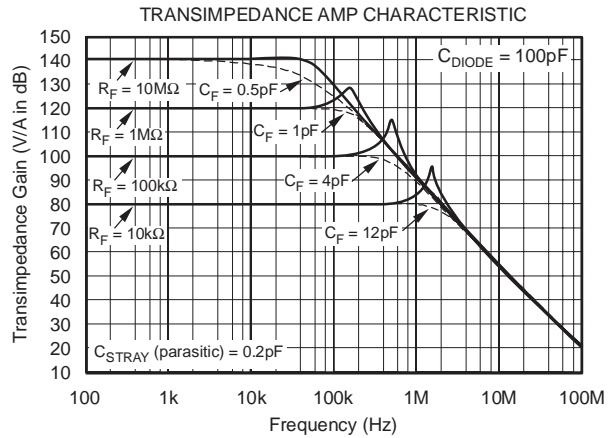
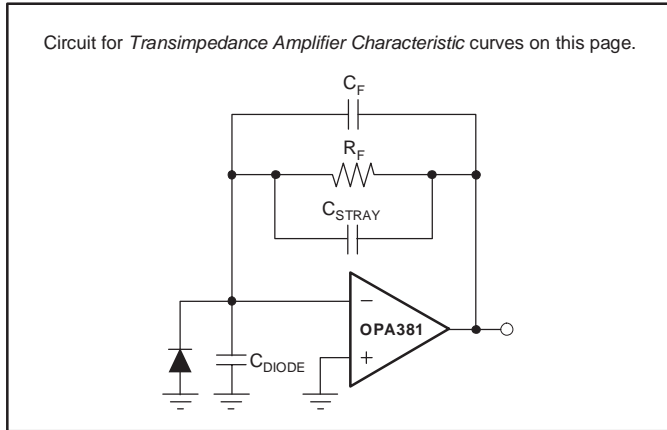

TYPICAL CHARACTERISTICS: $V_S = +2.7V$ to $+5.5V$ (continued)

All specifications at $T_A = +25^\circ C$, and $R_L = 10k\Omega$ connected to $V_S/2$, unless otherwise noted.

SMALL-SIGNAL STEP RESPONSE
(with or without pull-down)

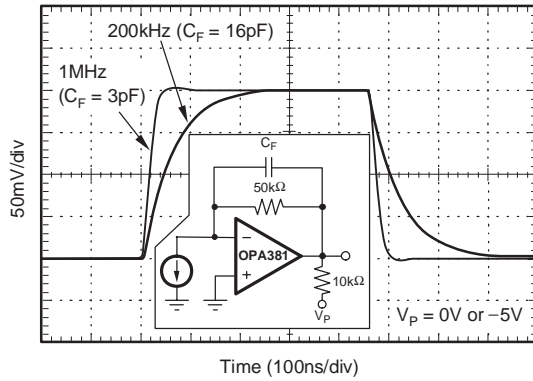

LARGE-SIGNAL STEP RESPONSE
(with pull-down)

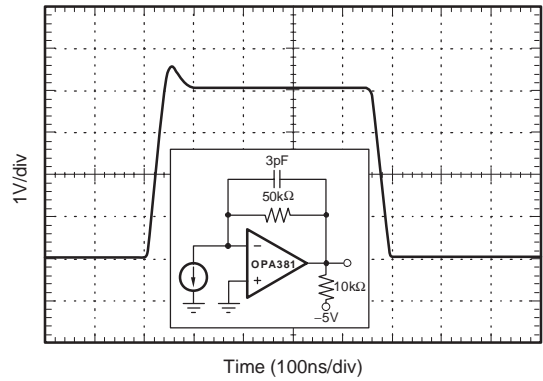

LARGE-SIGNAL STEP RESPONSE
(without pull-down)

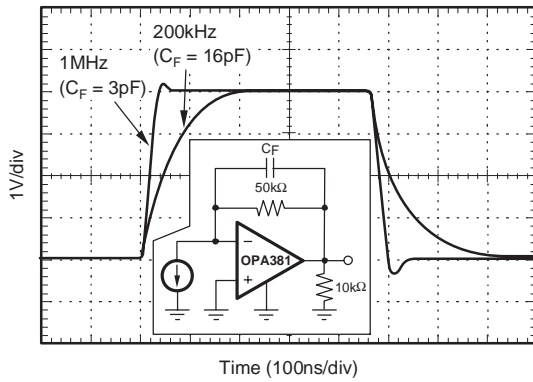

OVERLOAD RECOVERY

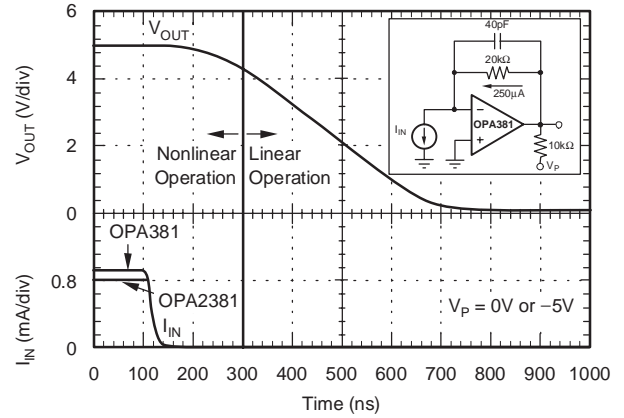

INPUT VOLTAGE NOISE SPECTRAL DENSITY

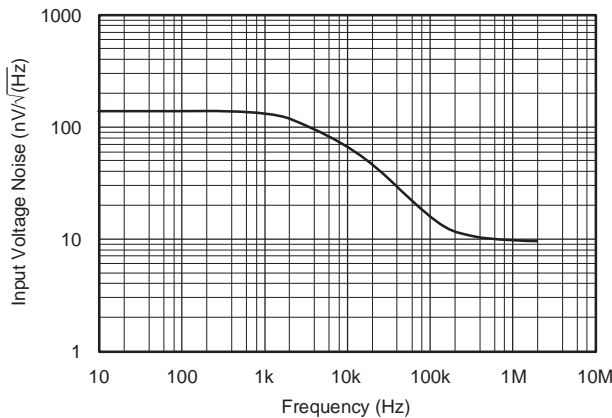

CHANNEL SEPARATION vs INPUT FREQUENCY

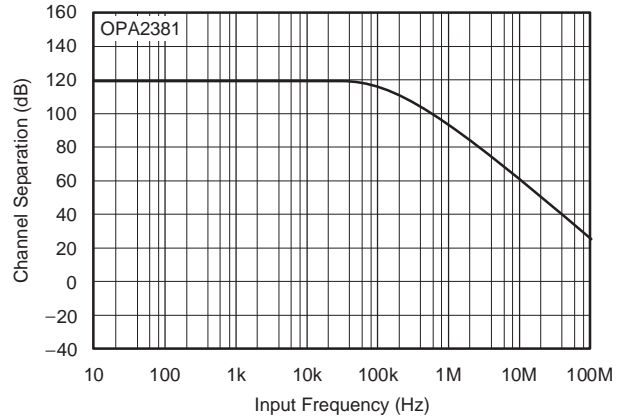

APPLICATIONS INFORMATION

BASIC OPERATION

The OPA381 is a high-precision transimpedance amplifier with very low 1/f noise. Due to its unique architecture, the OPA381 has excellent long-term input voltage offset stability.

The OPA381 performance results from an internal auto-zero amplifier combined with a high-speed amplifier. The OPA381 has been designed with circuitry to improve overload recovery and settling time over that achieved by a traditional composite approach. It has been specifically designed and characterized to accommodate circuit options to allow 0V output operation (see Figure 3).

The OPA381 is used in inverting configurations, with the noninverting input used as a fixed biasing point. Figure 1 shows the OPA381 in a typical configuration. Power-supply pins should be bypassed with 1 μ F ceramic or tantalum capacitors. Electrolytic capacitors are not recommended.

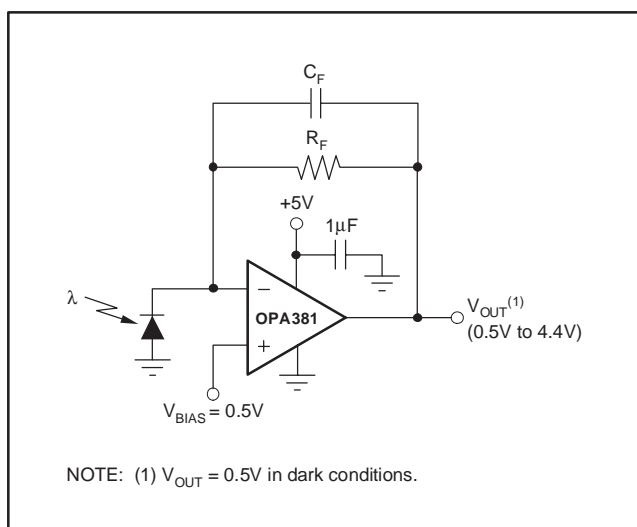

Figure 1. OPA381 Typical Configuration

OPERATING VOLTAGE

OPA381 series op amps are fully specified from 2.7V to 5.5V over a temperature range of $-40^{\circ}C$ to $+125^{\circ}C$. Parameters that vary significantly with operating voltages or temperature are shown in the Typical Characteristics.

INTERNAL OFFSET CORRECTION

The OPA381 series op amps use an auto-zero topology with a time-continuous 18MHz op amp in the signal path. This amplifier is zero-corrected every 100 μ s using a proprietary technique. Upon power-up, the amplifier requires approximately 400 μ s to achieve specified V_{OS} accuracy, which includes one full auto-zero cycle of approximately 100 μ s and the start-up time for the bias circuitry. Prior to this time, the amplifier will function properly but with unspecified offset voltage.

This design has virtually no aliasing and low noise. Zero correction occurs at a 10kHz rate, but there is virtually no fundamental noise energy present at that frequency due to internal filtering. For all practical purposes, any glitches have energy at 20MHz or higher and are easily filtered, if necessary. Most applications are not sensitive to such high-frequency noise, and no filtering is required.

INPUT VOLTAGE

The input common-mode voltage range of the OPA381 series extends from $V-$ to $(V+) - 1.8V$. With input signals above this common-mode range, the amplifier will no longer provide a valid output value, but it will not latch or invert.

INPUT OVERVOLTAGE PROTECTION

Device inputs are protected by ESD diodes that will conduct if the input voltages exceed the power supplies by more than approximately 500mV. Momentary voltages greater than 500mV beyond the power supply can be tolerated if the current is limited to 10mA. The OPA381 family features no phase inversion when the inputs extend beyond supplies if the input is current limited.

OUTPUT RANGE

The OPA381 is specified to swing within at least 600mV of the positive rail and 50mV of the negative rail with a 10kΩ load while maintaining good linearity. Swing to the negative rail while maintaining linearity can be extended to 0V—see the section, *Achieving Output Swing to Ground*. See the Typical Characteristic curve, *Output Voltage Swing vs Output Current*.

The OPA381 can swing slightly closer than specified to the positive rail; however, linearity will decrease and a high-speed overload recovery clamp limits the amount of positive output voltage swing available—see Figure 2.

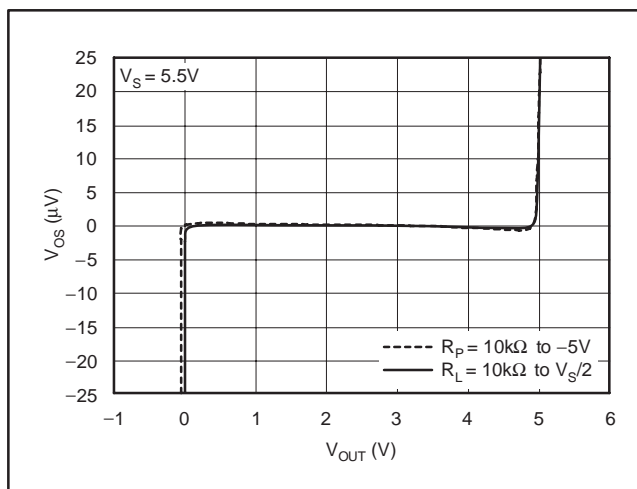

Figure 2. Effect of High-Speed Overload Recovery Clamp on Output Voltage

OVERLOAD RECOVERY

The OPA381 has been designed to prevent output saturation. After being overdriven to the positive rail, it will typically require only 200ns to return to linear operation. The time required for negative overload recovery is greater, *unless* a pulldown resistor connected to a more negative supply is used to extend the output swing all the way to the negative rail—see the following section, *Achieving Output Swing to Ground*.

ACHIEVING OUTPUT SWING TO GROUND

Some applications require output voltage swing from 0V to a positive full-scale voltage (such as +4.096V) with excellent accuracy. With most single-supply op amps, problems arise when the output signal approaches 0V, near the lower output swing limit of a single-supply op amp. A good single-supply op amp may swing close to single-supply ground, but will not reach 0V.

The output of the OPA381 can be made to swing to 0V, or slightly below, on a single-supply power source. This extended output swing requires the use of another resistor and an additional negative power supply. A pulldown resistor may be connected between the output and the negative supply to pull the output down to 0V; see Figure 3.

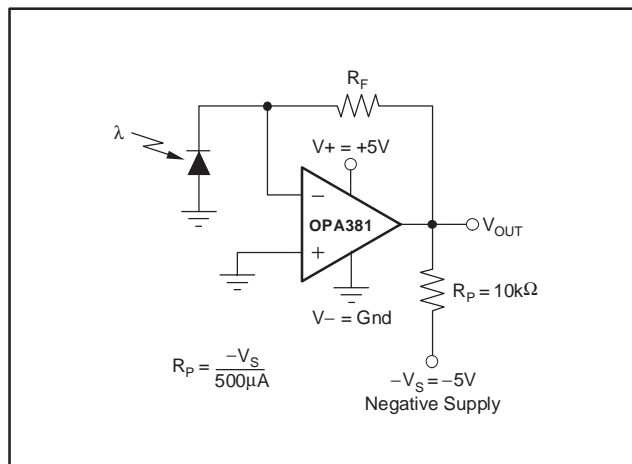

Figure 3. Amplifier with Pull-Down Resistor to Achieve $V_{OUT} = 0V$

The OPA381 has an output stage that allows the output voltage to be pulled to its negative supply rail using this technique. However, this technique only works with some types of output stages. The OPA381 has been designed to perform well with this method. Accuracy is excellent down to 0V. Reliable operation is assured over the specified temperature range.

BIASING PHOTODIODES IN SINGLE-SUPPLY CIRCUITS

The +IN input can be biased with a positive DC voltage to offset the output voltage and allow the amplifier output to indicate a true zero photodiode measurement when the photodiode is not exposed to any light. It will also prevent the added delay that results from coming out of the negative rail. This bias voltage appears across the photodiode, providing a reverse bias for faster operation. An RC filter placed at this bias point will reduce noise. (Refer to Figure 4.) This bias voltage can also serve as an offset bias point for an ADC with range that does not include ground.

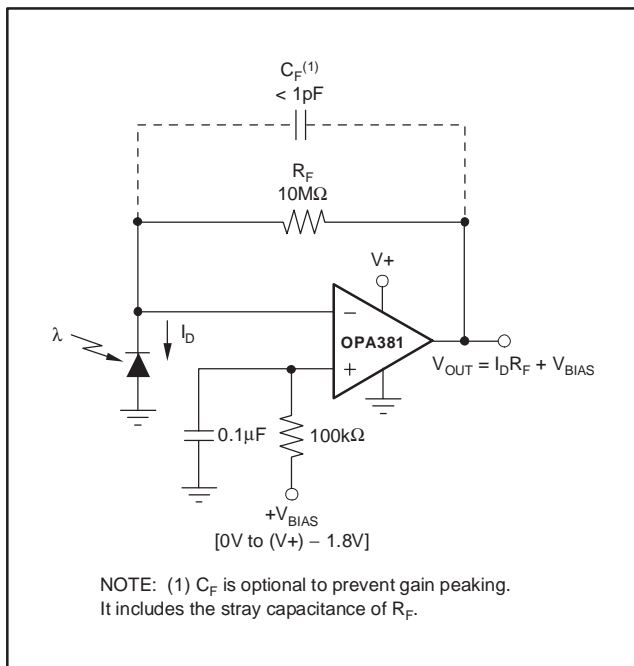

Figure 4. Photodiode with Filtered Reverse Bias Voltage

TRANSIMPEDANCE AMPLIFIER

Wide bandwidth, low input bias current and low input voltage and current noise make the OPA381 an ideal wideband photodiode transimpedance amplifier. Low voltage noise is important because photodiode capacitance causes the effective noise gain of the circuit to increase at high frequency.

The key elements to a transimpedance design are shown in Figure 5:

- the total input capacitance (C_{TOT}), consisting of the photodiode capacitance (C_{DIODE}) plus the parasitic common-mode and differential-mode input capacitance (2.5pF + 1pF for the OPA381);

- the desired transimpedance gain (R_F);
- the Gain Bandwidth Product (GBW) for the OPA381 (18MHz).

With these three variables set, the feedback capacitor value (C_F) can be set to control the frequency response. C_{STRAY} is the stray capacitance of R_F , which is 0.2pF for a typical surface-mount resistor.

To achieve a maximally flat 2nd-order Butterworth frequency response, the feedback pole should be set to:

$$\frac{1}{2\pi R_F (C_F + C_{STRAY})} = \sqrt{\frac{GBW}{4\pi R_F C_{TOT}}} \tag{1}$$

Bandwidth is calculated by:

$$f_{-3dB} = \sqrt{\frac{GBW}{2\pi R_F C_{TOT}}} \text{ Hz} \tag{2}$$

These equations will result in maximum transimpedance bandwidth. For even higher transimpedance bandwidth, the high-speed CMOS OPA380 (90MHz GBW), the OPA300 (150MHz GBW), or the OPA656 (230MHz GBW) may be used.

For additional information, refer to Application Bulletin AB-050 (SBOA055), *Compensate Transimpedance Amplifiers Intuitively*, available for download at www.ti.com.

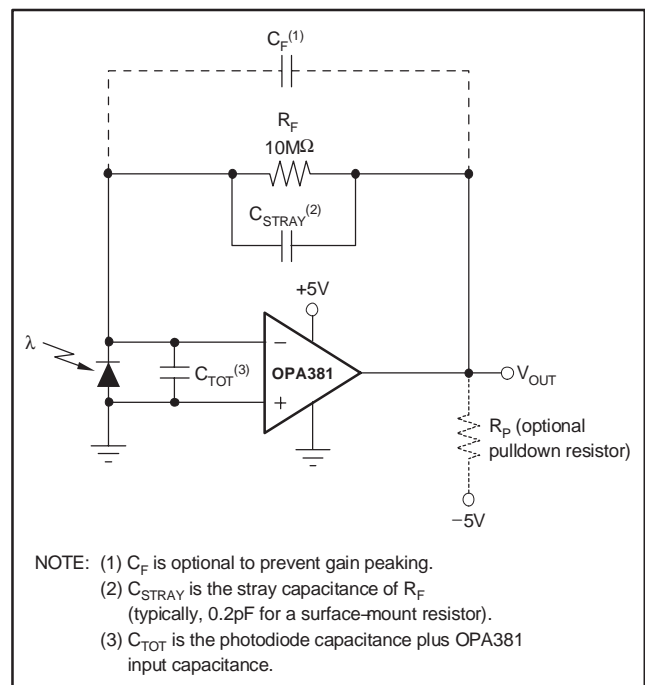

Figure 5. Transimpedance Amplifier

TRANSIMPEDANCE BANDWIDTH AND NOISE

Limiting the gain set by R_F can decrease the noise occurring at the output of the transimpedance circuit. However, all required gain should occur in the transimpedance stage, since adding gain after the transimpedance amplifier generally produces poorer noise performance. The noise spectral density produced by R_F increases with the square-root of R_F , whereas the signal increases linearly. Therefore, signal-to-noise ratio is improved when all the required gain is placed in the transimpedance stage.

Total noise increases with increased bandwidth. Limit the circuit bandwidth to only that required. Use a capacitor, C_F , across the feedback resistor, R_F , to limit bandwidth (even if not required for stability), if total output noise is a concern.

Figure 6a shows the transimpedance circuit without any feedback capacitor. The resulting transimpedance gain of this circuit is shown in Figure 7. The -3dB point is approximately 3MHz . Adding a 16pF feedback capacitor (Figure 6b) will limit the bandwidth and result in a -3dB point at approximately 200kHz (seen in Figure 7). Output noise will be further reduced by adding a filter (R_{FILTER} and C_{FILTER}) to create a second pole (Figure 6c). This second pole is placed within the feedback loop to maintain the amplifier's low output impedance. (If the pole was placed outside the feedback loop, an additional buffer would be required and would inadvertently increase noise and dc error).

Using R_{DIODE} to represent the equivalent diode resistance, and C_{TOT} for equivalent diode capacitance plus OPA381 input capacitance, the noise zero, f_z , is calculated by:

$$f_z = \frac{(R_{\text{DIODE}} + R_F)}{2\pi R_{\text{DIODE}} R_F (C_{\text{TOT}} + C_F)} \quad (3)$$

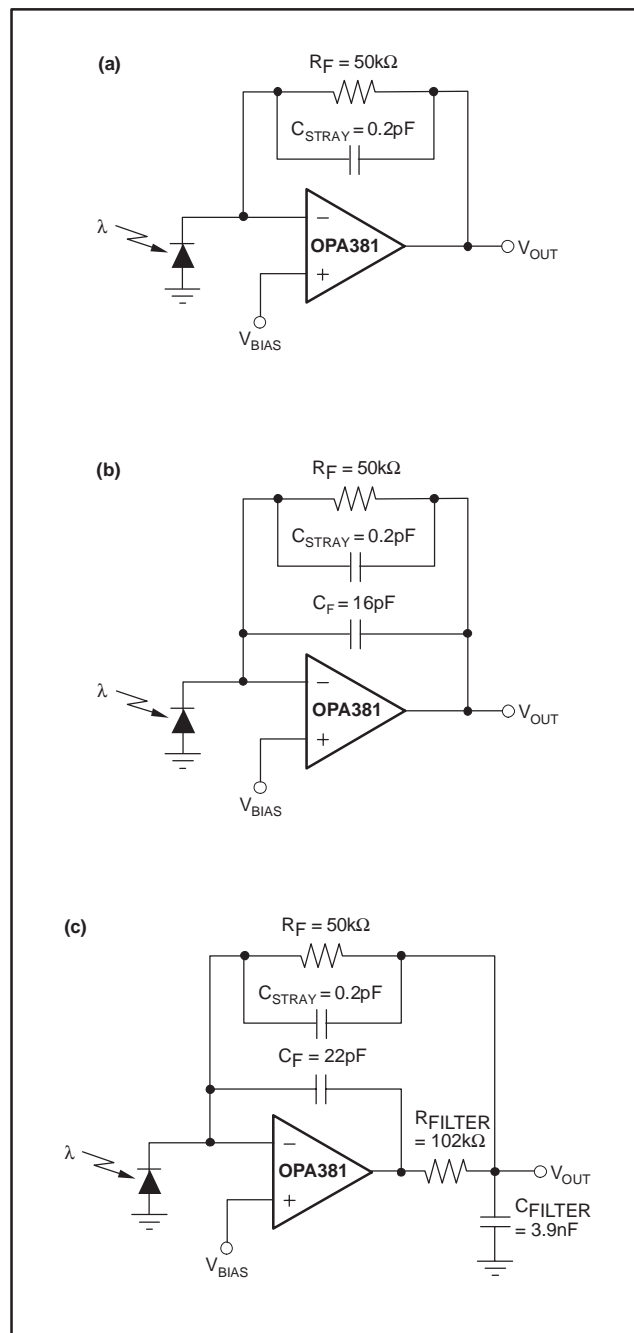

Figure 6. Transimpedance Circuit Configurations with Varying Total and Integrated Noise Gain

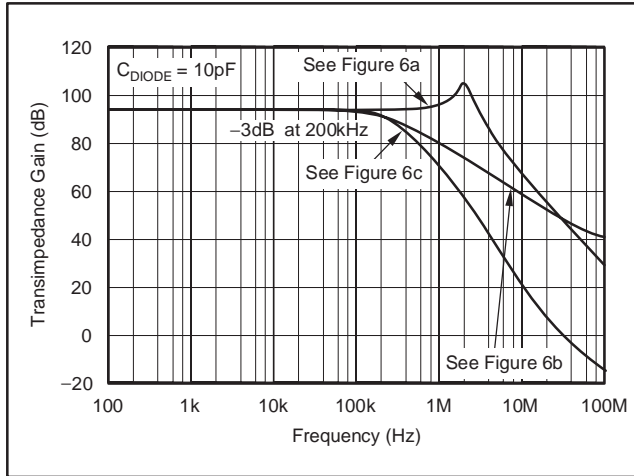

Figure 7. Transimpedance Gains for Circuits in Figure 6

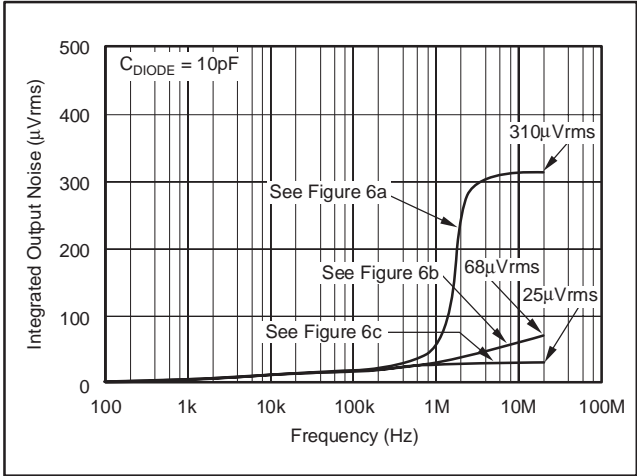

Figure 9. Integrated Output Noise for Circuits in Figure 6

The effects of these circuit configurations on output noise are shown in Figure 8 and on integrated output noise in Figure 9. A 2-pole Butterworth filter (maximally flat in passband) is created by selecting the filter values using the equation:

$$C_F R_F = 2C_{\text{FILTER}} R_{\text{FILTER}} \quad (4)$$

The circuit in Figure 6b rolls off at 20dB/decade. The circuit with the additional filter shown in Figure 6c rolls off at 40dB/decade, resulting in improved noise performance.

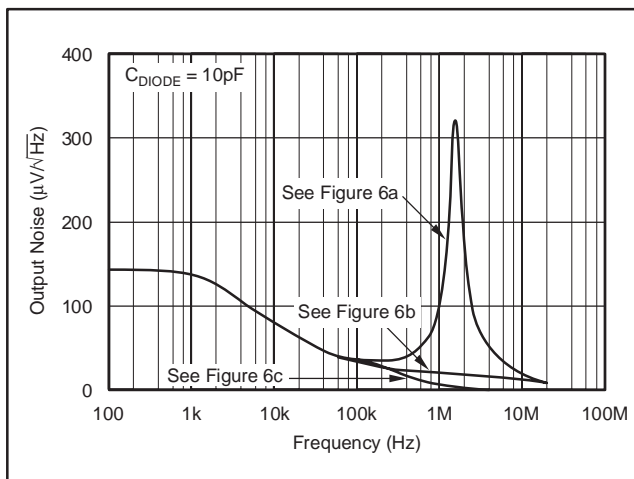

Figure 8. Output Noise for Circuits in Figure 6

Figure 10 shows the effects of diode capacitance on integrated output noise, using the circuit in Figure 6c. For additional information, refer to *Noise Analysis of FET Transimpedance Amplifiers* (SBOA060), and *Noise Analysis for High Speed Op Amps* (SBOA066), available for download from the TI web site.

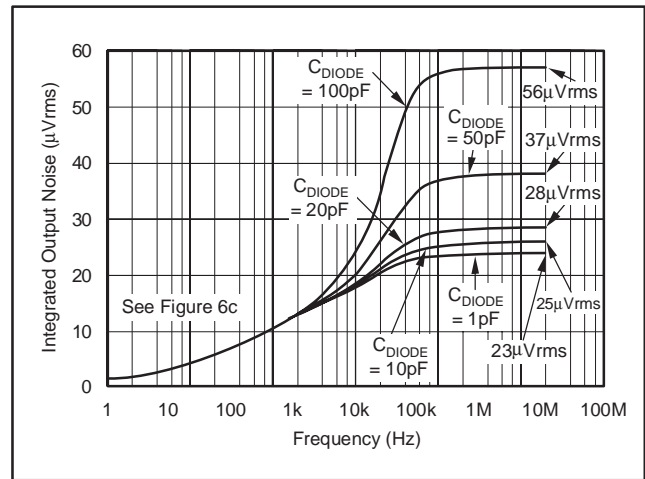

Figure 10. Integrated Output Noise for Various Values of C_{DIODE} for Circuit in Figure 6c

BOARD LAYOUT

Minimize photodiode capacitance and stray capacitance at the summing junction (inverting input). This capacitance causes the voltage noise of the op amp to be amplified (increasing amplification at high frequency). Using a low-noise voltage source to reverse-bias a photodiode can significantly reduce its capacitance. Smaller photodiodes have lower capacitance. Use optics to concentrate light on a small photodiode.

Circuit board leakage can degrade the performance of an otherwise well-designed amplifier. Clean the circuit board carefully. A circuit board guard trace that encircles the summing junction and is driven at the same voltage can help control leakage. See Figure 11.

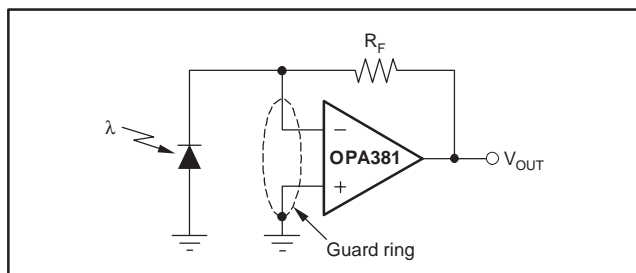

Figure 11. Connection of Input Guard

OTHER WAYS TO MEASURE SMALL CURRENTS

Logarithmic amplifiers are used to compress extremely wide dynamic range input currents to a much narrower range. Wide input dynamic ranges of 8 decades, or 100pA to 10mA, can be accommodated for input to a 12-bit ADC. (Suggested products: LOG101, LOG102, LOG104, LOG112.)

Extremely small currents can be accurately measured by integrating currents on a capacitor. (Suggested product: IVC102.)

Low-level currents can be converted to high-resolution data words. (Suggested product: DDC112.)

For further information on the range of products available, search www.ti.com using the above specific model names or by using keywords *transimpedance* and *logarithmic*.

CAPACITIVE LOAD AND STABILITY

The OPA381 series op amps can drive greater than 100pF pure capacitive load. Increasing the gain enhances the amplifier's ability to drive greater capacitive loads. See the *Phase Margin vs Load Capacitance* typical characteristic curve.

One method of improving capacitive load drive in the unity-gain configuration is to insert a 10Ω to 20Ω resistor inside the feedback loop, as shown in Figure 12. This reduces ringing with large capacitive loads while maintaining DC accuracy.

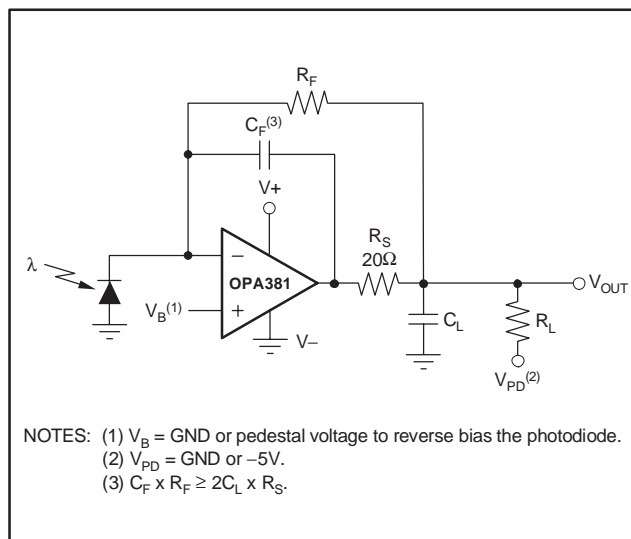

Figure 12. Series Resistor in Unity-Gain Buffer Configuration Improves Capacitive Load Drive

DRIVING 16-BIT ANALOG-TO-DIGITAL CONVERTERS (ADC)

The OPA381 series is optimized for driving a 16-bit ADC such as the ADS8325. The OPA381 op amp buffers the converter input capacitance and resulting charge injection while providing signal gain. Figure 13 shows the OPA381 in a single-ended method of interfacing the ADS8325 16-bit, 100kSPS ADC. For additional information, refer to the ADS8325 data sheet.

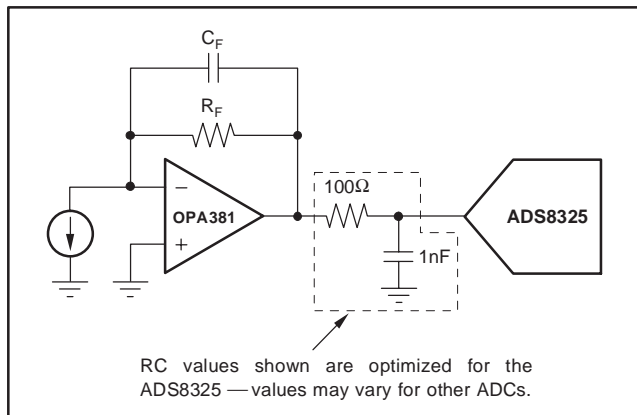

Figure 13. Driving 16-Bit ADCs

INVERTING AMPLIFIER

Its excellent dc precision characteristics make the OPA381 also useful as an inverting amplifier. Figure 14 shows it configured for use on a single-supply set to a gain of 10.

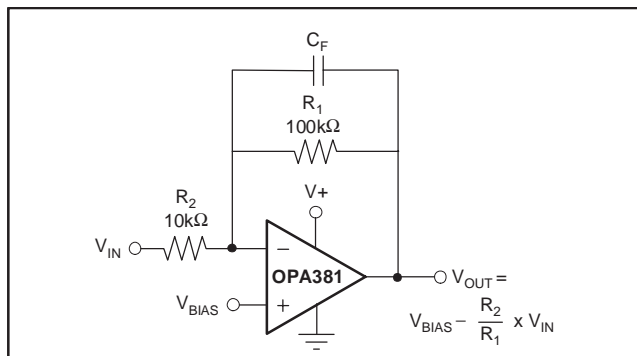

Figure 14. Inverting Gain

PRECISION INTEGRATOR

With its low offset voltage, the OPA381 is well-suited for use as an integrator. Some applications require a means to reset the integration. The circuit shown in Figure 15 uses a mechanical switch as the reset mechanism. The switch is opened at the beginning of the integration period. It is shown in the open position, which is the integration mode. With the values of R_1 and C_1 shown, the output changes $-1V/s$ per volt of input.

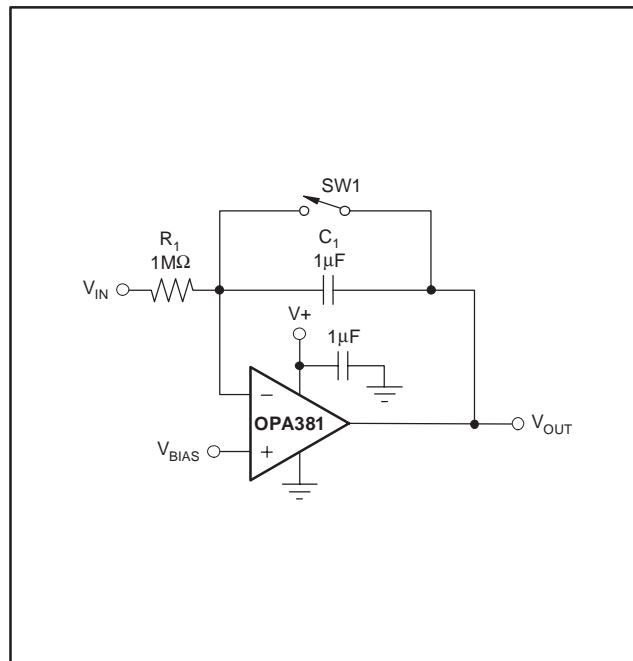

Figure 15. Precision Integrator

DFN (DRB) THERMALLY-ENHANCED PACKAGE

One of the package options for the OPA381 and OPA2381 is the DFN-8 package, a thermally-enhanced package designed to eliminate the use of bulky heat sinks and slugs traditionally used in thermal packages. The absence of external leads eliminates bent-lead concerns and issues.

Although the power dissipation requirements of a given application might not require a heat sink, for mechanical reliability, the exposed power pad must be soldered to the board and connected to $V-$ (pin 4). This package can be easily mounted using standard PCB assembly techniques. See Application Note SLUA271, *QFN/SON PCB Attachment*, located at www.ti.com. These DFN packages have reliable solderability with either SnPb or Pb-free solder paste.

DRB (S-PDSO-N8)

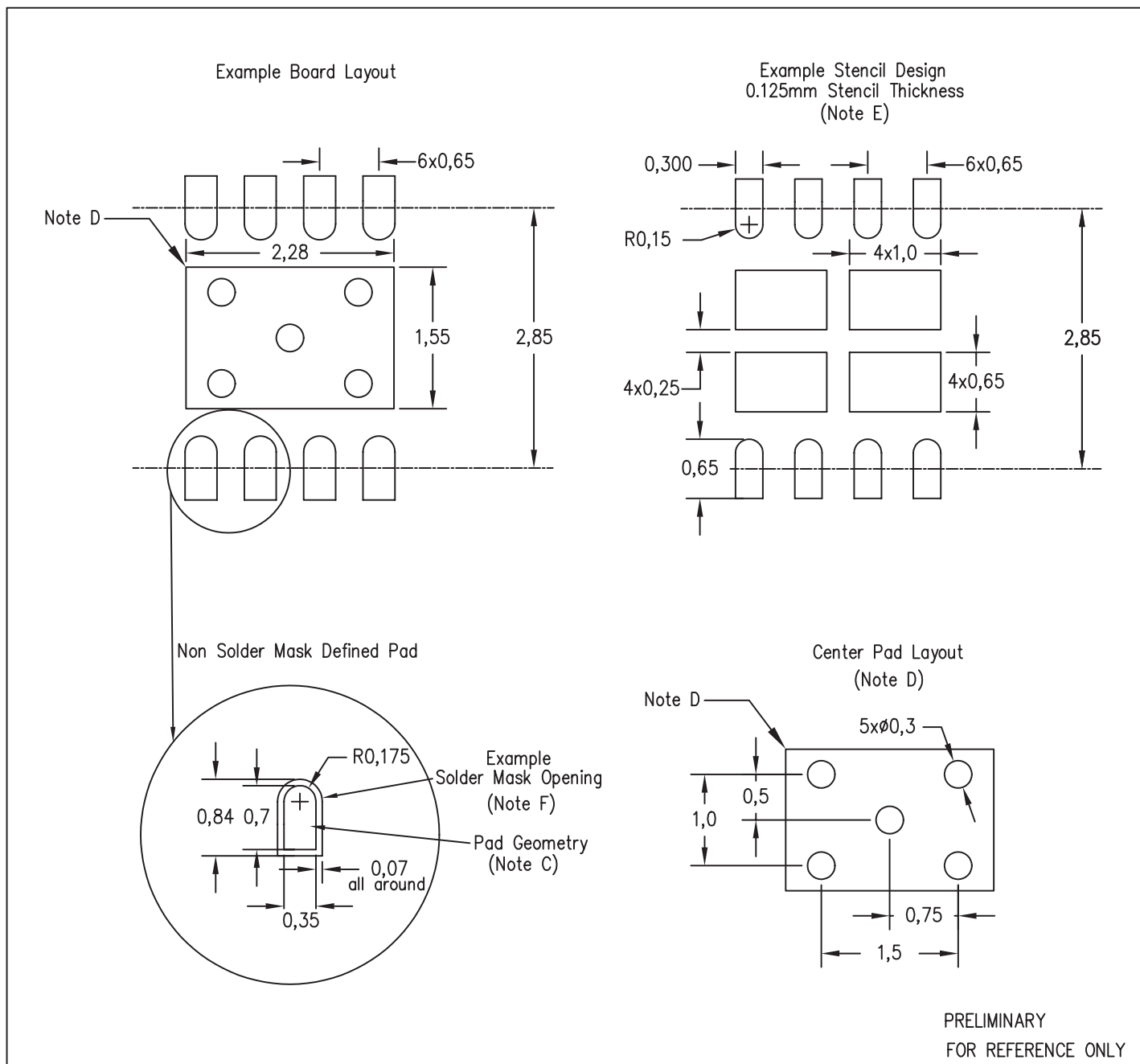

- NOTES:
- All linear dimensions are in millimeters.
 - This drawing is subject to change without notice.
 - Publication IPC-SM-782 is recommended for alternate designs.
 - This package is designed to be soldered to a thermal pad on the board. Refer to Application Note, QFN Packages, Texas Instruments Literature No. SCBA017, SLUA271, and also the Product Data Sheets for specific thermal information, via requirements, and recommended board layout. These documents are available at www.ti.com <<http://www.ti.com>>.
 - Laser cutting apertures with trapezoidal walls and also rounding corners will offer better paste release. Customers should contact their board assembly site for stencil design recommendations. Refer to IPC 7525 for stencil design considerations.
 - Customers should contact their board fabrication site for solder mask tolerances.

PACKAGING INFORMATION

Orderable Device	Status ⁽¹⁾	Package Type	Package Drawing	Pins	Package Qty	Eco Plan ⁽²⁾	Lead/Ball Finish	MSL Peak Temp ⁽³⁾
OPA2381AIDGKR	ACTIVE	MSOP	DGK	8	2500	None	Call TI	Level-1-240C-UNLIM
OPA2381AIDGKT	ACTIVE	MSOP	DGK	8	250	None	Call TI	Level-1-240C-UNLIM
OPA2381AIDRBR	ACTIVE	SON	DRB	8	3000	None	Call TI	Level-1-240C-UNLIM
OPA2381AIDRBT	ACTIVE	SON	DRB	8	250	None	Call TI	Level-1-240C-UNLIM
OPA381AIDGKR	ACTIVE	MSOP	DGK	8	2500	None	CU NIPDAU	Level-1-240C-UNLIM
OPA381AIDGKT	ACTIVE	MSOP	DGK	8	250	None	CU NIPDAU	Level-1-240C-UNLIM
OPA381AIDRBR	ACTIVE	SON	DRB	8	3000	None	Call TI	Level-1-240C-UNLIM
OPA381AIDRBT	ACTIVE	SON	DRB	8	250	None	Call TI	Level-1-240C-UNLIM

⁽¹⁾ The marketing status values are defined as follows:

ACTIVE: Product device recommended for new designs.

LIFEBUY: TI has announced that the device will be discontinued, and a lifetime-buy period is in effect.

NRND: Not recommended for new designs. Device is in production to support existing customers, but TI does not recommend using this part in a new design.

PREVIEW: Device has been announced but is not in production. Samples may or may not be available.

OBSOLETE: TI has discontinued the production of the device.

⁽²⁾ Eco Plan - May not be currently available - please check <http://www.ti.com/productcontent> for the latest availability information and additional product content details.

None: Not yet available Lead (Pb-Free).

Pb-Free (RoHS): TI's terms "Lead-Free" or "Pb-Free" mean semiconductor products that are compatible with the current RoHS requirements for all 6 substances, including the requirement that lead not exceed 0.1% by weight in homogeneous materials. Where designed to be soldered at high temperatures, TI Pb-Free products are suitable for use in specified lead-free processes.

Green (RoHS & no Sb/Br): TI defines "Green" to mean "Pb-Free" and in addition, uses package materials that do not contain halogens, including bromine (Br) or antimony (Sb) above 0.1% of total product weight.

⁽³⁾ MSL, Peak Temp. -- The Moisture Sensitivity Level rating according to the JEDEC industry standard classifications, and peak solder temperature.

Important Information and Disclaimer: The information provided on this page represents TI's knowledge and belief as of the date that it is provided. TI bases its knowledge and belief on information provided by third parties, and makes no representation or warranty as to the accuracy of such information. Efforts are underway to better integrate information from third parties. TI has taken and continues to take reasonable steps to provide representative and accurate information but may not have conducted destructive testing or chemical analysis on incoming materials and chemicals. TI and TI suppliers consider certain information to be proprietary, and thus CAS numbers and other limited information may not be available for release.

In no event shall TI's liability arising out of such information exceed the total purchase price of the TI part(s) at issue in this document sold by TI to Customer on an annual basis.

DGK (S-PDSO-G8)

PLASTIC SMALL-OUTLINE PACKAGE

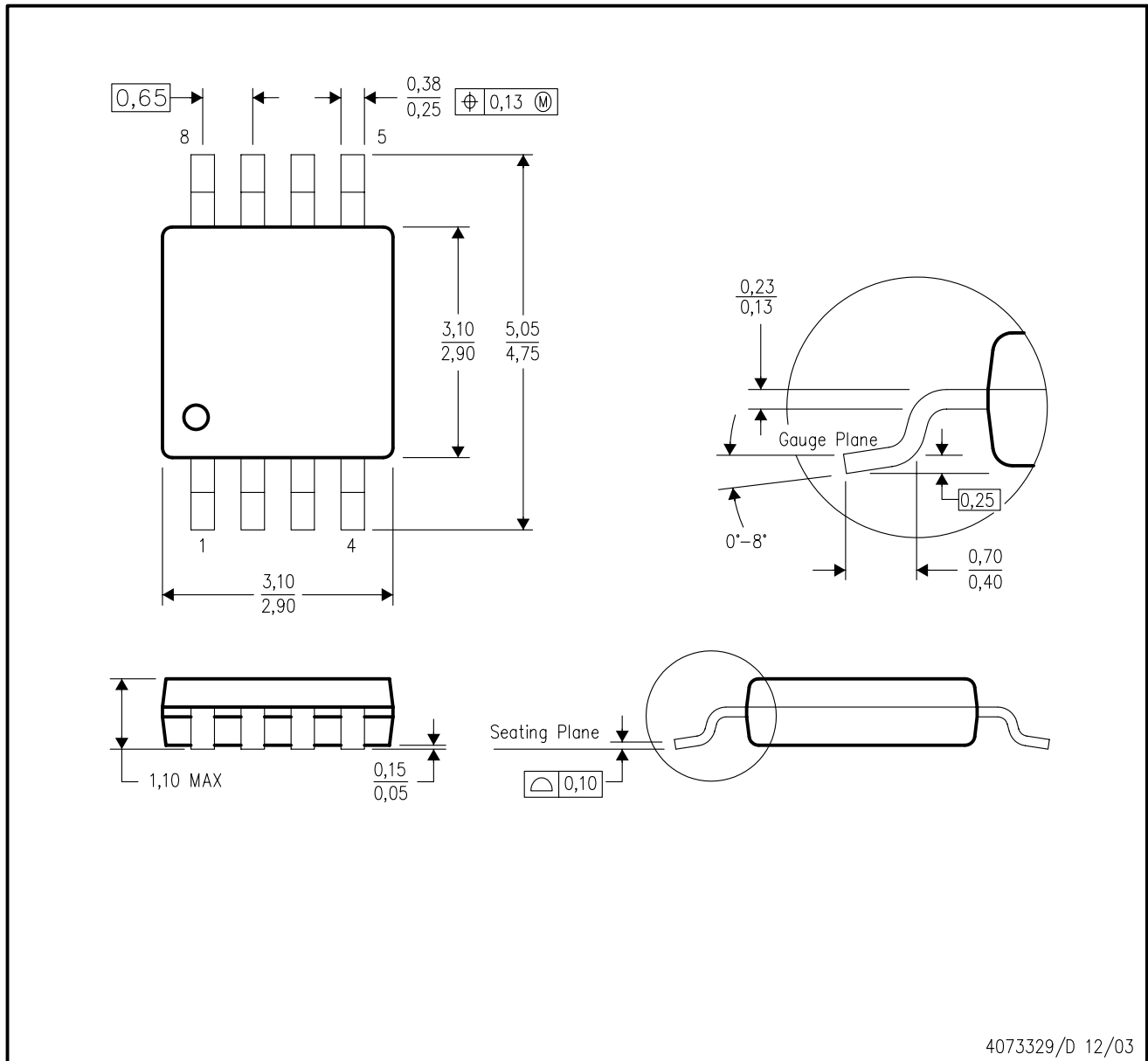

- NOTES:
- A. All linear dimensions are in millimeters.
 - B. This drawing is subject to change without notice.
 - C. Body dimensions do not include mold flash or protrusion.
 - D. Falls within JEDEC MO-187 variation AA.

DRB (S-PDSO-N8)

PLASTIC SMALL OUTLINE

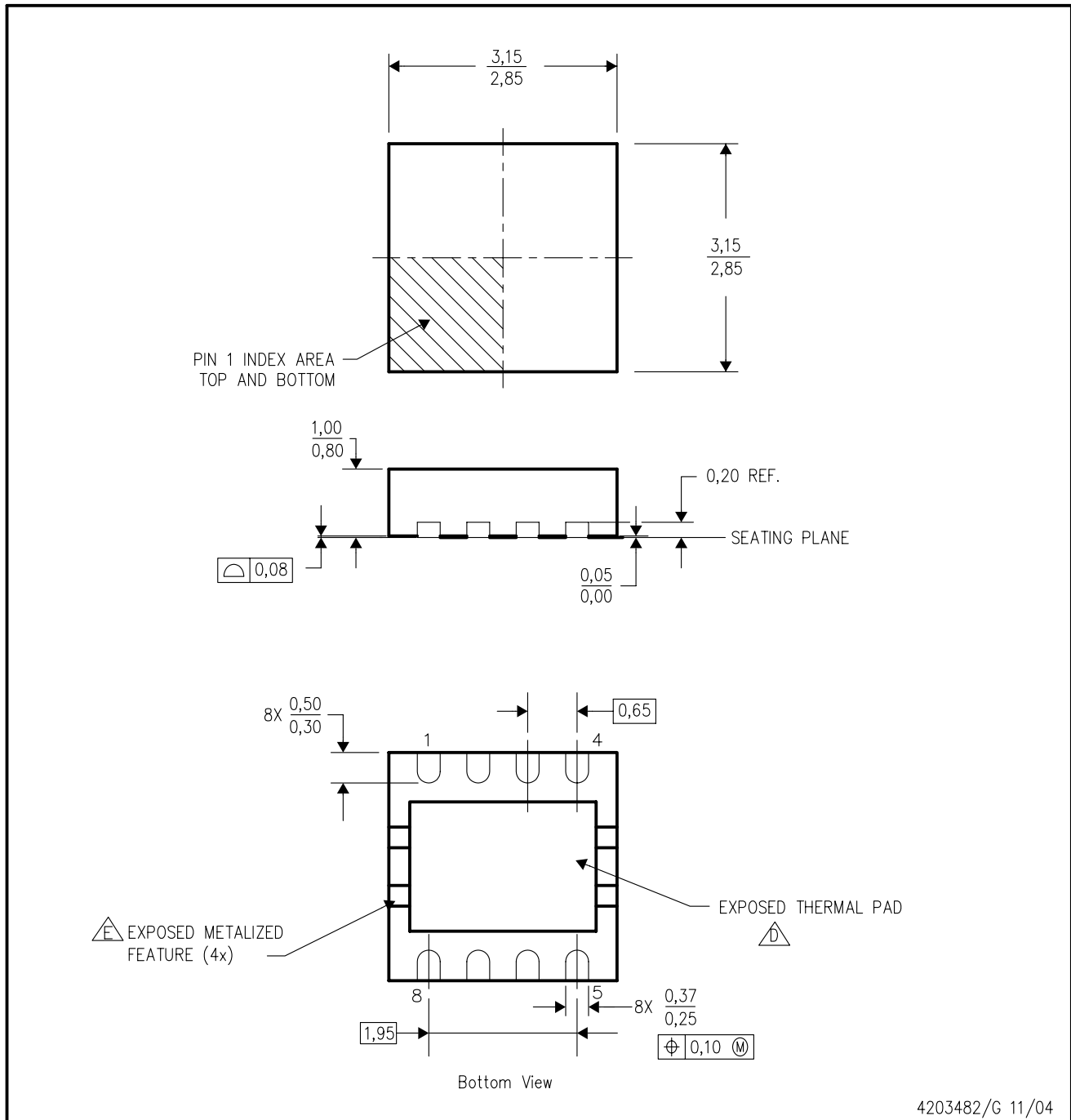

- NOTES:
- A. All linear dimensions are in millimeters. Dimensioning and tolerancing per ASME Y14.5M-1994.
 - B. This drawing is subject to change without notice.
 - C. Small Outline No-Lead (SON) package configuration.
 - The package thermal pad must be soldered to the board for thermal and mechanical performance. See the Product Data Sheet for details regarding the exposed thermal pad dimensions.
 - Metalized features are supplier options and may not be on the package.

IMPORTANT NOTICE

Texas Instruments Incorporated and its subsidiaries (TI) reserve the right to make corrections, modifications, enhancements, improvements, and other changes to its products and services at any time and to discontinue any product or service without notice. Customers should obtain the latest relevant information before placing orders and should verify that such information is current and complete. All products are sold subject to TI's terms and conditions of sale supplied at the time of order acknowledgment.

TI warrants performance of its hardware products to the specifications applicable at the time of sale in accordance with TI's standard warranty. Testing and other quality control techniques are used to the extent TI deems necessary to support this warranty. Except where mandated by government requirements, testing of all parameters of each product is not necessarily performed.

TI assumes no liability for applications assistance or customer product design. Customers are responsible for their products and applications using TI components. To minimize the risks associated with customer products and applications, customers should provide adequate design and operating safeguards.

TI does not warrant or represent that any license, either express or implied, is granted under any TI patent right, copyright, mask work right, or other TI intellectual property right relating to any combination, machine, or process in which TI products or services are used. Information published by TI regarding third-party products or services does not constitute a license from TI to use such products or services or a warranty or endorsement thereof. Use of such information may require a license from a third party under the patents or other intellectual property of the third party, or a license from TI under the patents or other intellectual property of TI.

Reproduction of information in TI data books or data sheets is permissible only if reproduction is without alteration and is accompanied by all associated warranties, conditions, limitations, and notices. Reproduction of this information with alteration is an unfair and deceptive business practice. TI is not responsible or liable for such altered documentation.

Resale of TI products or services with statements different from or beyond the parameters stated by TI for that product or service voids all express and any implied warranties for the associated TI product or service and is an unfair and deceptive business practice. TI is not responsible or liable for any such statements.

Following are URLs where you can obtain information on other Texas Instruments products and application solutions:

Products		Applications	
Amplifiers	amplifier.ti.com	Audio	www.ti.com/audio
Data Converters	dataconverter.ti.com	Automotive	www.ti.com/automotive
DSP	dsp.ti.com	Broadband	www.ti.com/broadband
Interface	interface.ti.com	Digital Control	www.ti.com/digitalcontrol
Logic	logic.ti.com	Military	www.ti.com/military
Power Mgmt	power.ti.com	Optical Networking	www.ti.com/opticalnetwork
Microcontrollers	microcontroller.ti.com	Security	www.ti.com/security
		Telephony	www.ti.com/telephony
		Video & Imaging	www.ti.com/video
		Wireless	www.ti.com/wireless

Mailing Address: Texas Instruments
Post Office Box 655303 Dallas, Texas 75265

Copyright © 2004, Texas Instruments Incorporated