

NLSX0102

2-Bit 20 Mb/s Dual-Supply Level Translator

The NLSX0102 is a 2-bit configurable dual-supply bidirectional auto sensing translator that does not require a directional control pin. The I/O V_{CC} and I/O V_L ports are designed to track two different power supply rails, V_{CC} and V_L respectively. Both the V_{CC} and V_L supply rails are configurable from 1.5 V to 5.5 V. This allows voltage logic signals on the V_L side to be translated into lower, higher or equal value voltage logic signals on the V_{CC} side, and vice-versa.

The NLSX0102 translator has integrated 10 k Ω pull-up resistors on the I/O lines. The integrated pull-up resistors are used to pull-up the I/O lines to either V_L or V_{CC} . The NLSX0102 is an excellent match for open-drain applications such as the I²C communication bus.

Features

- V_L can be Less than, Greater than or Equal to V_{CC}
- Wide V_{CC} Operating Range: 1.5 V to 5.5 V
Wide V_L Operating Range: 1.5 V to 5.5 V
- High-Speed with 24 Mb/s Guaranteed Data Rate
- Low Bit-to-Bit Skew
- Enable Input and I/O Pins are Overvoltage Tolerant (OVT) to 5.5 V
- Non-preferential Power-up Sequencing
- Integrated 10 k Ω Pull-up Resistors
- Small Space Saving Package
– 1.9 mm x 0.9 mm x 0.5 mm Flipchip8
- This is a Pb-Free Device

Typical Applications

- I²C, SMBus
- Low Voltage ASIC Level Translation
- Mobile Phones, PDAs, Cameras

Important Information

- ESD Protection for All Pins
– Human Body Model (HBM) > 7000 V



ON Semiconductor®

www.onsemi.com

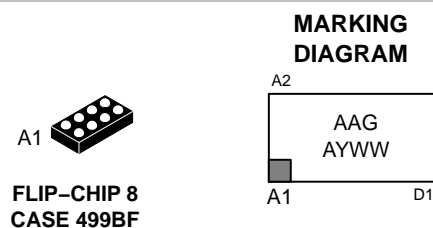

AAG = Specific Device Code
A = Assembly Location
Y = Year
WW = Work Week

PIN ASSIGNMENTS

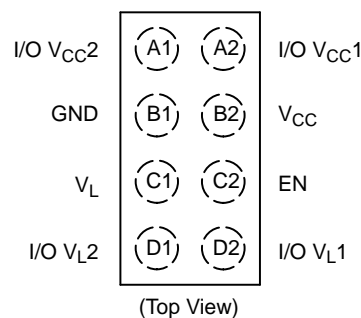

LOGIC DIAGRAM

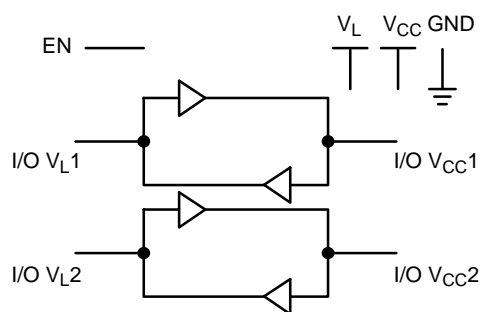

ORDERING INFORMATION

See detailed ordering and shipping information in the package dimensions section on page 9 of this data sheet.

NLSX0102

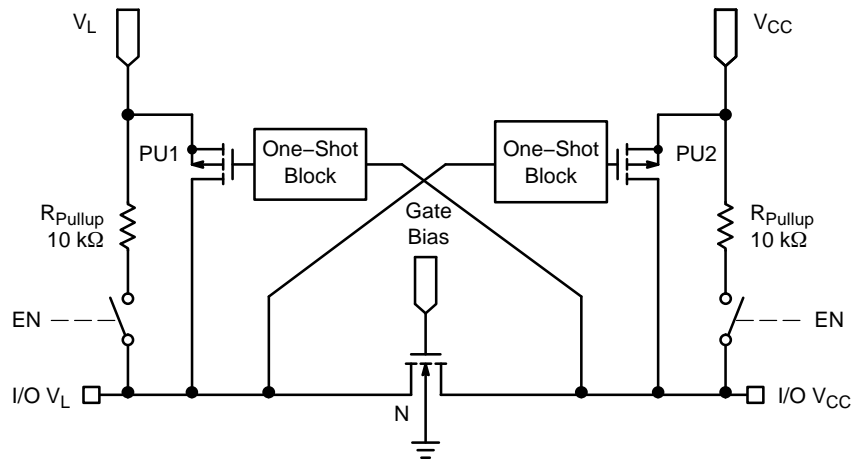

Figure 1. Block Diagram (1 I/O Line)

PIN ASSIGNMENT

Pins	Description
V_{CC}	V_{CC} Supply Voltage
V_L	V_L Supply Voltage
GND	Ground
EN	Output Enable, referenced to V_L
I/O V_{CCn}	I/O Port, referenced to V_{CC}
I/O V_{Ln}	I/O Port, referenced to V_L

FUNCTION TABLE

EN	Operating Mode
L	Hi-Z
H	I/O Buses Connected

MAXIMUM RATINGS

Symbol	Parameter	Value	Condition	Unit
V_{CC}	High-side DC Supply Voltage	-0.5 to +7.0		V
V_L	Low-side DC Supply Voltage	-0.5 to +7.0		V
I/O V_{CC}	V_{CC} -referenced DC Input / Output Voltage	-0.5 to +7.0		V
I/O V_L	V_L -referenced DC Input / Output Voltage	-0.5 to +7.0		V
V_{EN}	Enable Control Pin DC Input Voltage	-0.5 to +7.0		V
I_{I/O_SC}	Short-Circuit Duration (I/O V_L and I/O V_{CC} to GND)	±50	Continuous	mA
$I_{I/O\>OK}$	Input / Output Clamping Current (I/O V_L and I/O V_{CC})	-50	$V_{I/O} < 0$	mA
T_{STG}	Storage Temperature	-65 to +150		°C

Stresses exceeding those listed in the Maximum Ratings table may damage the device. If any of these limits are exceeded, device functionality should not be assumed, damage may occur and reliability may be affected.

NLSX0102

RECOMMENDED OPERATING CONDITIONS

Symbol	Parameter	Min	Max	Unit
V_{CC}	High-side Positive DC Supply Voltage	1.5	5.5	V
V_L	Low-side Positive DC Supply Voltage	1.5	5.5	V
V_{EN}	Enable Control Pin Voltage	GND	5.5	V
V_{IO}	I/O Pin Voltage	GND	5.5	V
$\Delta t/\Delta V$	Input Transition Rise and Fall Rate I/O V_L and I/O V_{CC} Ports, Push-Pull Driving		10	ns/V
	Control Input		10	
T_A	Operating Temperature Range	-40	+85	°C

DC ELECTRICAL CHARACTERISTICS ($T_A = -40$ to $+85$ °C, unless otherwise specified)

Symbol	Parameter	Test Conditions (Note 1)	V_L	V_{CC}	-40 °C to +85 °C			Unit
					Min	Typ (Notes 1, 2)	Max	
V_{IHC}	I/O V_{CC} Input HIGH Voltage		1.5 to 5.5	1.5 to 5.5	$V_{CC} - 0.4$		-	V
V_{ILC}	I/O V_{CC} Input LOW Voltage		1.5 to 5.5	1.5 to 5.5			0.15	V
V_{IHL}	I/O V_L Input HIGH Voltage		1.5 to 5.5	1.5 to 5.5	$V_L - 0.4$		-	V
V_{ILL}	I/O V_L Input LOW Voltage		1.5 to 5.5	1.5 to 5.5			0.15	V
V_{IH}	Control Pin Input HIGH Voltage		1.5 to 5.5	1.5 to 5.5	$0.65 * V_L$		-	V
V_{IL}	Control Pin Input LOW Voltage		1.5 to 5.5	1.5 to 5.5			$0.35 * V_L$	V
V_{OHC}	I/O V_{CC} Output HIGH Voltage	I/O V_{CC} source current = $-20 \mu A$	1.5 to 5.5	1.5 to 5.5	$2/3 * V_{CC}$		-	V
V_{OLC}	I/O V_{CC} Output LOW Voltage	I/O V_{CC} sink current = 1 mA	1.5 to 5.5	1.5 to 5.5			0.4	V
V_{OHL}	I/O V_L Output HIGH Voltage	I/O V_L source current = $-20 \mu A$	1.5 to 5.5	1.5 to 5.5	$2/3 * V_L$		-	V
V_{OLL}	I/O V_L Output LOW Voltage	I/O V_L sink current = 1 mA	1.5 to 5.5	1.5 to 5.5			0.4	V
I_{QVL}	V_L Supply Current Supply Current	I/O V_{CC} and I/O V_L unconnected, $V_{EN} = V_L$	1.5 to 5.5	1.5 to 5.5			2.0	μA
			5.5	0			2.0	
			0	5.5			-1.0	
I_{QVCC}	V_L Supply Current Supply Current	I/O V_{CC} and I/O V_L unconnected, $V_{EN} = V_L$	1.5 to 5.5	1.5 to 5.5			2.0	μA
			5.5	0			2.0	
			0	5.5			-1.0	
I_{TS-VCC}	V_{CC} Tri-state Output Mode	I/O V_{CC} and I/O V_L unconnected, $V_{EN} = GND$	1.5 to 5.5	1.5 to 5.5			1.0	μA
I_{TS-VL}	V_L Tri-state Output Mode Supply Current	I/O V_{CC} and I/O V_L unconnected, $V_{EN} = GND$	1.5 to 5.5	1.5 to 5.5			1.0	μA

1. Typical values are for $V_{CC} = +3.3$ V, $V_L = +1.8$ V and $T_A = +25$ °C.

2. All units are production tested at $T_A = +25$ °C. Limits over the operating temperature range are guaranteed by design.

NLSX0102

DC ELECTRICAL CHARACTERISTICS ($T_A = -40$ to $+85$ °C, unless otherwise specified)

Symbol	Parameter	Test Conditions (Note 1)	V_L	V_{CC}	-40 °C to +85 °C			Unit
					Min	Typ (Notes 1, 2)	Max	
I_I	Enable Pin Input Leakage Current		1.5 to 5.5	1.5 to 5.5			1.0	μ A
I_{OZ}	I/O Tri-state Output Mode Leakage Current		1.5 to 5.5	1.5 to 5.5			1.0	μ A
R_{PU}	Pull-Up Resistors I/O V_L and V_C					10		k Ω

1. Typical values are for $V_{CC} = +3.3$ V, $V_L = +1.8$ V and $T_A = +25$ °C.
2. All units are production tested at $T_A = +25$ °C. Limits over the operating temperature range are guaranteed by design.

Timing Characteristics – Rail-to-Rail Driving Configuration

(I/O test circuits of Figures 2, 3 and 7, $C_{LOAD} = 15$ pF, driver output impedance ≤ 50 Ω , $R_{LOAD} = 1$ M Ω , unless otherwise specified)

Symbol	Parameter	Conditions	-40 °C to +85 °C						Unit
			$V_{CC} = 2.3$ to 2.7 V		$V_{CC} = 3.0$ to 3.6 V		$V_{CC} = 4.5$ to 5.5 V		
			Min	Max	Min	Max	Min	Max	

$V_L = 1.65$ to 1.95 V

t_{RVL}	I/O V_L Rise Time	Figure 8	0.6	9.5	2.3	12.5	0.8	7.6	nS
t_{RVCC}	I/O V_{CC} Rise Time	Figure 8	4.0	10.8	2.7	9.1	2.7	7.6	nS
t_{FVL}	I/O V_L Fall Time	Figure 8	2.0	9.7	1.9	8.1	1.7	13.3	nS
t_{FVCC}	I/O V_{CC} Fall Time	Figure 8	2.9	13.8	2.8	16.2	2.8	16.2	nS
$t_{PHL-VL-VCC}$	Propagation Delay (Driving I/O V_L , V_L to V_{CC})	Figure 2		5.6		7.1		6.8	nS
$t_{PLH-VL-VCC}$				6.5		7.1		7.4	
$t_{PHL-VCC-VL}$	Propagation Delay (Driving I/O V_{CC} , V_{CC} to V_L)	Figure 3		4.8		5.3		2.0	nS
$t_{PLH-VCC-VL}$				4.8		5.0		3.5	
t_{EN}	Enable Time	Figure 7		50		40		35	nS
t_{DIS}	Disable Time	Figure 7		316		225		215	nS
t_{PPSKEW}	Part-to-Part Skew			0.7		0.7		0.7	nS
MDR	Maximum Data Rate		21		22		24		Mbps

$V_L = 2.3$ to 2.7 V

t_{RVL}	I/O V_L Rise Time	Figure 8	2.8	7.7	2.6	8.1	1.8	10.3	nS
t_{RVCC}	I/O V_{CC} Rise Time	Figure 8	3.2	9.2	2.9	8.8	2.4	6.4	nS
t_{FVL}	I/O V_L Fall Time	Figure 8	1.9	8.3	1.9	7.8	1.8	7.4	nS
t_{FVCC}	I/O V_{CC} Fall Time	Figure 8	2.2	8.3	2.4	8.0	2.6	10.0	nS
$t_{PHL-VL-VCC}$	Propagation Delay (Driving I/O V_L , V_L to V_{CC})	Figure 2		3.2		3.7		3.9	nS
$t_{PLH-VL-VCC}$				4.8		5.3		6.0	
$t_{PHL-VCC-VL}$	Propagation Delay (Driving I/O V_{CC} , V_{CC} to V_L)	Figure 3		2.5		1.6		1.0	nS
$t_{PLH-VCC-VL}$				4.5		4.3		3.4	
t_{EN}	Enable Time	Figure 7		50		40		35	nS
t_{DIS}	Disable Time	Figure 7		225		225		215	nS
t_{PPSKEW}	Part-to-Part Skew			0.7		0.7		0.7	nS
MDR	Maximum Data Rate		20		22		24		Mbps

NLSX0102

Timing Characteristics – Rail-to-Rail Driving Configuration

(I/O test circuits of Figures 2, 3 and 7, $C_{LOAD} = 15 \text{ pF}$, driver output impedance $\leq 50 \Omega$, $R_{LOAD} = 1 \text{ M}\Omega$, unless otherwise specified)

Symbol	Parameter	Conditions	-40°C to +85°C						Unit
			V _{CC} = 2.3 to 2.7 V		V _{CC} = 3.0 to 3.6 V		V _{CC} = 4.5 to 5.5 V		
			Min	Max	Min	Max	Min	Max	

V_L = 3.0 to 3.6 V

t _{RVL}	I/O V _L Rise Time	Figure 8			2.3	6.5	1.9	8.0	nS
t _{RVCC}	I/O V _{CC} Rise Time	Figure 8			2.5	6.5	2.1	7.4	nS
t _{FVL}	I/O V _L Fall Time	Figure 8			2.0	7.2	1.9	5.9	nS
t _{FVCC}	I/O V _{CC} Fall Time	Figure 8			2.3	8.0	2.4	9.3	nS
t _{PHL-VL-VCC}	Propagation Delay (Driving I/O V _L , V _L to V _{CC})	Figure 2				2.4		3.1	nS
t _{PLH-VL-VCC}						3.8		3.8	
t _{PHL-VCC-VL}	Propagation Delay (Driving I/O V _{CC} , V _{CC} to V _L)	Figure 3				2.5		2.6	nS
t _{PLH-VCC-VL}						3.6		3.1	
t _{EN}	Enable Time	Figure 7				40		35	nS
t _{DIS}	Disable Time	Figure 7				225		235	nS
t _{PPSKEW}	Part-to-Part Skew					0.7		0.7	nS
MDR	Maximum Data Rate				23		24		Mbps

Timing Characteristics – Open Drain Driving Configuration

(I/O test circuits of Figures 4, 5 and 7, $C_{LOAD} = 15 \text{ pF}$, driver output impedance $\leq 50 \Omega$, $R_{LOAD} = 1 \text{ M}\Omega$, unless otherwise specified)

Symbol	Parameter	Conditions	-40°C to +85°C						Unit
			V _{CC} = 2.3 to 2.7 V		V _{CC} = 3.0 to 3.6 V		V _{CC} = 4.5 to 5.5 V		
			Min	Max	Min	Max	Min	Max	

V_L = 1.65 to 1.95 V

t _{RVL}	I/O V _L Rise Time	Figure 8	38	340	30	245	22.0	134	nS
t _{RVCC}	I/O V _{CC} Rise Time	Figure 8	34	330	23	218	10.0	120	nS
t _{FVL}	I/O V _L Fall Time	Figure 8	4.4	11.1	4.3	12.0	4.2	14.2	nS
t _{FVCC}	I/O V _{CC} Fall Time	Figure 8	6.9	11	7.5	16.2	7.0	16.2	nS
t _{PHLVL-VCC}	Propagation Delay (Driving I/O V _L , V _L to V _{CC})	Figure 2	2.3	27	2.4	20.0	2.6	23.0	nS
t _{PLHVL-VCC}			45	260	36.0	208	27.0	208	
t _{PHLVCC-VL}	Propagation Delay (Driving I/O V _{CC} , V _{CC} to V _L)	Figure 3	1.9	22	1.1	22.0	1.2	22.0	nS
t _{PLHVCC-VL}			45.0	200	36	150	27.0	112	
t _{EN}	Enable Time	Figure 7		80		70		35	nS
t _{DIS}	Disable Time	Figure 7		250		277		290	nS
t _{PPSKEW}	Part-to-Part Skew			0.7		0.7		0.7	nS
MDR	Maximum Data Rate		2		2		2		Mbps

NLSX0102

Timing Characteristics – Open Drain Driving Configuration

(I/O test circuits of Figures 4, 5 and 7, C_{LOAD} = 15 pF, driver output impedance ≤ 50 Ω, R_{LOAD} = 1 MΩ, unless otherwise specified)

Symbol	Parameter	Conditions	-40°C to +85°C						Unit
			V _{CC} = 2.3 to 2.7 V		V _{CC} = 3.0 to 3.6 V		V _{CC} = 4.5 to 5.5 V		
			Min	Max	Min	Max	Min	Max	

V_L = 2.3 to 2.7 V

t _{RVL}	I/O V _L Rise Time	Figure 8	34	400	28.0	300	24.0	208	nS
t _{RVCC}	I/O V _{CC} Rise Time	Figure 8	35.0	352	24.0	280	12.0	180	nS
t _{FVL}	I/O V _L Fall Time	Figure 8	4.4	6.9	4.3	6.2	4.2	7.8	nS
t _{FVCC}	I/O V _{CC} Fall Time	Figure 8	4.3	8.8	4.9	9.4	5.4	10.4	nS
t _{PHLVL-VCC}	Propagation Delay (Driving I/O V _L , V _L to V _{CC})	Figure 2	1.7	14.0	2.0	14.0	2.1	14.0	nS
t _{PLHVL-VCC}			43.0	250	36.0	210	27.0	210	
t _{PHLVCC-VL}	Propagation Delay (Driving I/O V _{CC} , V _{CC} to V _L)	Figure 3	1.8	13.0	2.6	13.0	1.2	13.0	nS
t _{PLHVCC-VL}			44.0	225	37.0	180	27.0	144	
t _{EN}	Enable Time	Figure 7		50		40		35	nS
t _{DIS}	Disable Time	Figure 7		265		230		215	nS
t _{PPSKEW}	Part-to-Part Skew			0.7		0.7		0.7	nS
MDR	Maximum Data Rate		2		2		2		Mbps

V_L = 3.0 to 3.6 V

t _{RVL}	I/O V _L Rise Time	Figure 8			25.0	400	19.0	278	nS
t _{RVCC}	I/O V _{CC} Rise Time	Figure 8			26.0	375	14.0	247	nS
t _{FVL}	I/O V _L Fall Time	Figure 8			2.8	6.1	2.6	5.7	nS
t _{FVCC}	I/O V _{CC} Fall Time	Figure 8			2.6	7.6	3.1	8.3	nS
t _{PHLVL-VCC}	Propagation Delay (Driving I/O V _L , V _L to V _{CC})	Figure 2			1.3	10.0	1.4	8.0	nS
t _{PLHVL-VCC}					36.0	255	28.0	243	
t _{PHLVCC-VL}	Propagation Delay (Driving I/O V _{CC} , V _{CC} to V _L)	Figure 3			1.0	124	1.0	97.0	nS
t _{PLHVCC-VL}					3.0	185	3.0	136	
t _{EN}	Enable Time	Figure 7				40		35	nS
t _{DIS}	Disable Time	Figure 7				250		205	nS
t _{PPSKEW}	Part-to-Part Skew					0.7		0.7	nS
MDR	Maximum Data Rate				2		2		Mbps

NLSX0102

TEST SETUPS

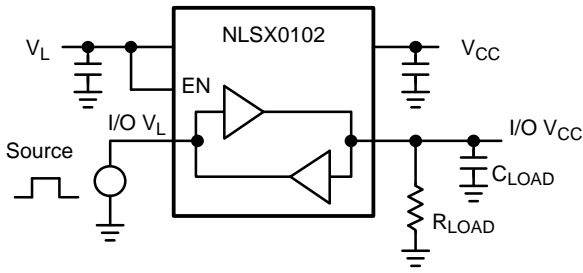

Figure 2. Rail-to-Rail Driving I/O V_L

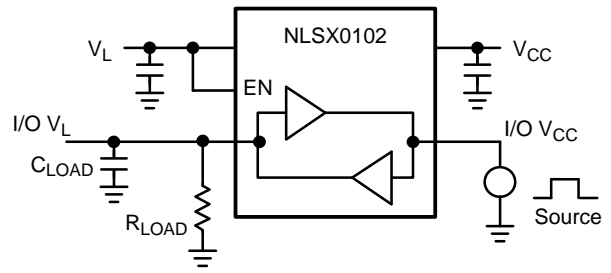

Figure 3. Rail-to-Rail Driving I/O V_{CC}

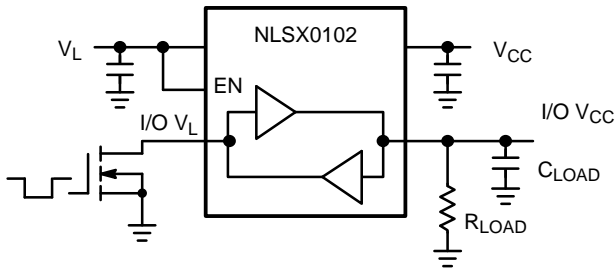

Figure 4. Open-Drain Driving I/O V_L

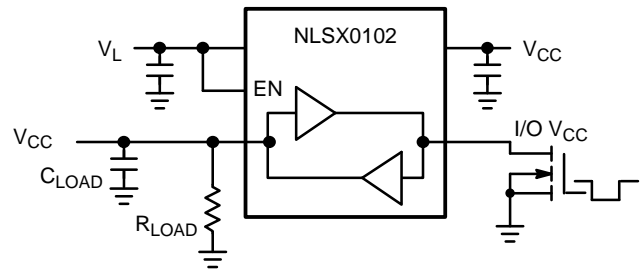

Figure 5. Open-Drain Driving I/O V_{CC}

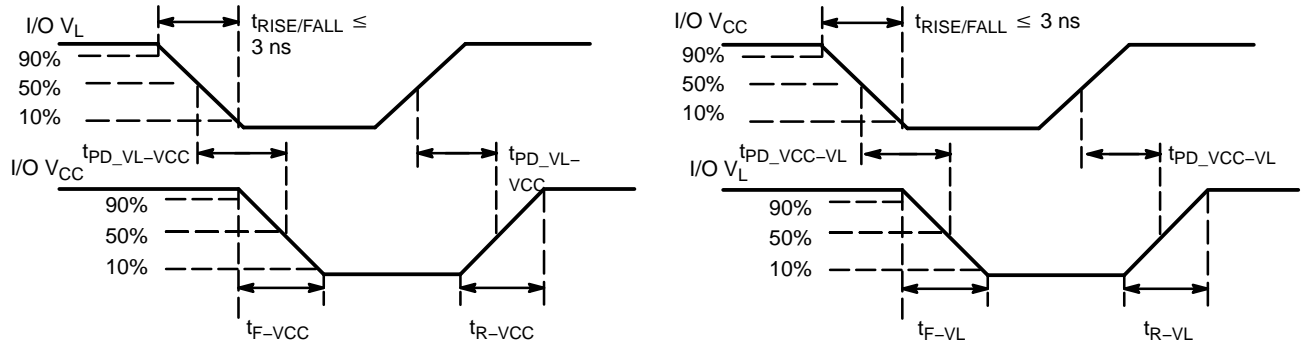
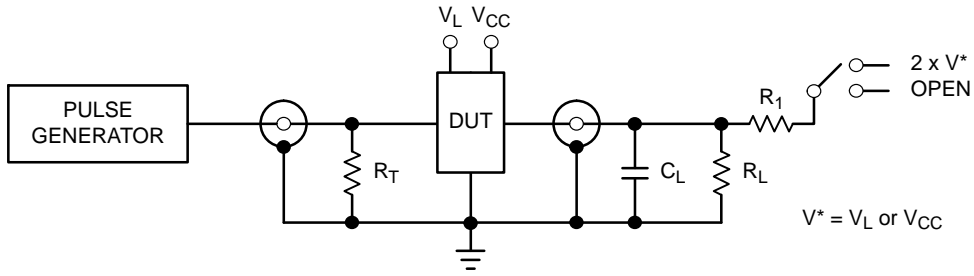

Figure 6. Definition of Timing Specification Parameters

NLSX0102



Test	Switch
t_{PZH}, t_{PHZ}	Open
t_{PZL}, t_{PLZ}	$2 \times V^*$

$C_L = 15 \text{ pF}$ or equivalent (Includes jig and probe capacitance)
 $R_L = R_1 = 50 \text{ k}\Omega$ or equivalent
 $R_T = Z_{OUT}$ of pulse generator (typically 50Ω)
 $V^* = V_L$ or V_{CC} for I/O_VL or I/O_VCC measurements, respectively.

Figure 7. Test Circuit for Enable/Disable Time Measurement

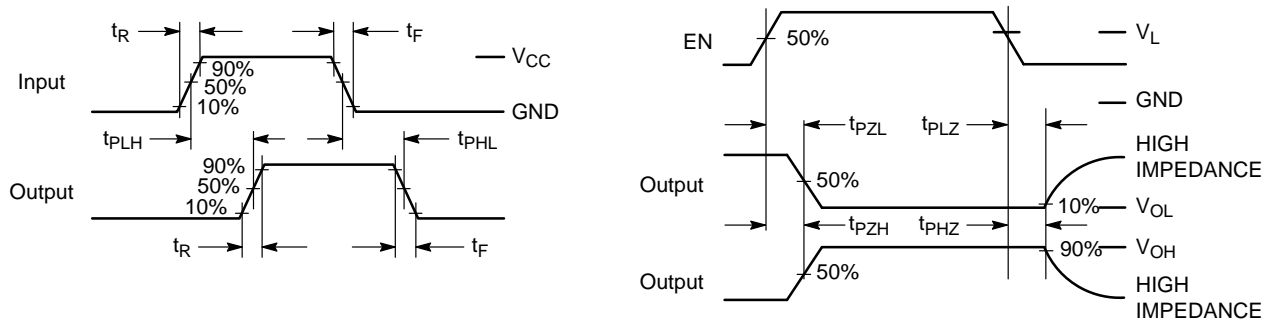

Figure 8. Timing Definitions for Propagation Delays and Enable/Disable Measurement

NLSX0102

APPLICATIONS INFORMATION

Level Translator Architecture

The NLSX0102 auto sense translator provides bi-directional voltage level shifting to transfer data in multiple supply voltage systems. This device has two supply voltages, V_L and V_{CC} , which set the logic levels on the input and output sides of the translator. When used to transfer data from the V_L to the V_{CC} ports, input signals referenced to the V_L supply are translated to output signals with a logic level matched to V_{CC} . In a similar manner, the V_{CC} to V_L translation shifts input signals with a logic level compatible to V_{CC} to an output signal matched to V_L .

The NLSX0102 consists of two bi-directional channels that independently determine the direction of the data flow without requiring a directional pin. The one-shot circuits are used to detect the rising or falling input signals. In addition, the one shots decrease the rise and fall time of the output signal for high-to-low and low-to-high transitions. Each input/output channel has an internal 10 k Ω pull-up. The magnitude of the pull-up resistors can be reduced by connecting external resistors in parallel to the internal 10 k Ω resistors.

Input Driver Requirements

The rise (t_R) and fall (t_F) timing parameters of the open drain outputs depend on the magnitude of the pull-up resistors. In addition, the propagation times (t_{PD}), skew (t_{PSKEW}) and maximum data rate depend on the impedance

of the device that is connected to the translator. The timing parameters listed in the data sheet assume that the output impedance of the drivers connected to the translator is less than 50 k Ω .

Enable Input (EN)

The NLSX0102 has an Enable pin (EN) that provides tri-state operation at the I/O pins. Driving the Enable pin to a low logic level minimizes the power consumption of the device and drives the I/O V_{CC} and I/O V_L pins to a high impedance state. Normal translation operation occurs when the EN pin is equal to a logic high signal. The EN pin is referenced to the V_L supply and has Overvoltage Tolerant (OVT) protection.

Power Supply Guidelines

During normal operation, supply voltage V_L can be greater than, less than or equal to V_{CC} . The sequencing of the power supplies will not damage the device during the power up operation. For optimal performance, 0.01 μ F to 0.1 μ F decoupling capacitors should be used on the V_L and V_{CC} power supply pins. Ceramic capacitors are a good design choice to filter and bypass any noise signals on the voltage lines to the ground plane of the PCB. The noise immunity will be maximized by placing the capacitors as close as possible to the supply and ground pins, along with minimizing the PCB connection traces.

ORDERING INFORMATION

Device	Package	Shipping†
NLSX0102FCT1G	Flip-Chip 8 (Pb-Free)	3000 / Tape & Reel
NLSX0102FCT2G	Flip-Chip 8 (Pb-Free)	3000 / Tape & Reel (4mm Pitch Carrier Tape)
NLSX0102FC2T2G	Flip-Chip 8 (Pb-Free)	3000 / Tape & Reel (2mm Pitch Carrier Tape)

†For information on tape and reel specifications, including part orientation and tape sizes, please refer to our Tape and Reel Packaging Specifications Brochure, BRD8011/D.

NLSX0102

PACKAGE DIMENSIONS

8 PIN FLIP-CHIP, 0.9x1.9, 0.5P CASE 499BF ISSUE O

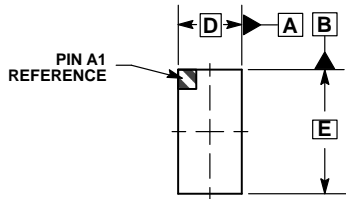

TOP VIEW

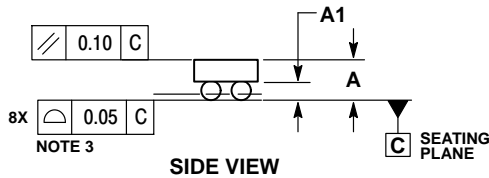

SIDE VIEW

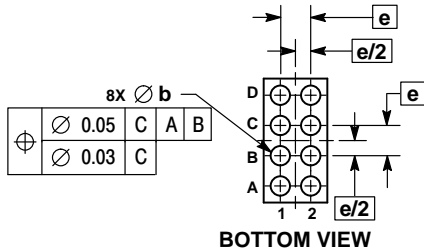

BOTTOM VIEW

NOTES:

1. DIMENSIONING AND TOLERANCING PER ASME Y14.5M, 1994.
2. CONTROLLING DIMENSION: MILLIMETERS.
3. COPLANARITY APPLIES TO SPHERICAL CROWNS OF SOLDER BALLS.

MILLIMETERS		
DIM	MIN	MAX
A	0.44	0.50
A1	0.15	0.19
b	0.21	0.25
D	0.90 BSC	
E	1.90 BSC	
e	0.50 BSC	

SOLDERING FOOTPRINT*

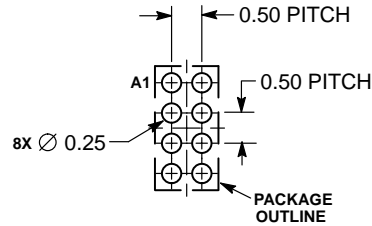

*For additional information on our Pb-Free strategy and soldering details, please download the ON Semiconductor Soldering and Mounting Techniques Reference Manual, SOLDERRM/D.

ON Semiconductor and are trademarks of Semiconductor Components Industries, LLC dba ON Semiconductor or its subsidiaries in the United States and/or other countries. ON Semiconductor owns the rights to a number of patents, trademarks, copyrights, trade secrets, and other intellectual property. A listing of ON Semiconductor's product/patent coverage may be accessed at www.onsemi.com/site/pdf/Patent-Marking.pdf. ON Semiconductor reserves the right to make changes without further notice to any products herein. ON Semiconductor makes no warranty, representation or guarantee regarding the suitability of its products for any particular purpose, nor does ON Semiconductor assume any liability arising out of the application or use of any product or circuit, and specifically disclaims any and all liability, including without limitation special, consequential or incidental damages. Buyer is responsible for its products and applications using ON Semiconductor products, including compliance with all laws, regulations and safety requirements or standards, regardless of any support or applications information provided by ON Semiconductor. "Typical" parameters which may be provided in ON Semiconductor data sheets and/or specifications can and do vary in different applications and actual performance may vary over time. All operating parameters, including "Typicals" must be validated for each customer application by customer's technical experts. ON Semiconductor does not convey any license under its patent rights nor the rights of others. ON Semiconductor products are not designed, intended, or authorized for use as a critical component in life support systems or any FDA Class 3 medical devices or medical devices with a same or similar classification in a foreign jurisdiction or any devices intended for implantation in the human body. Should Buyer purchase or use ON Semiconductor products for any such unintended or unauthorized application, Buyer shall indemnify and hold ON Semiconductor and its officers, employees, subsidiaries, affiliates, and distributors harmless against all claims, costs, damages, and expenses, and reasonable attorney fees arising out of, directly or indirectly, any claim of personal injury or death associated with such unintended or unauthorized use, even if such claim alleges that ON Semiconductor was negligent regarding the design or manufacture of the part. ON Semiconductor is an Equal Opportunity/Affirmative Action Employer. This literature is subject to all applicable copyright laws and is not for resale in any manner.

PUBLICATION ORDERING INFORMATION

LITERATURE FULFILLMENT:

Literature Distribution Center for ON Semiconductor
19521 E. 32nd Pkwy, Aurora, Colorado 80011 USA
Phone: 303-675-2175 or 800-344-3860 Toll Free USA/Canada
Fax: 303-675-2176 or 800-344-3867 Toll Free USA/Canada
Email: orderlit@onsemi.com

N. American Technical Support: 800-282-9855 Toll Free
USA/Canada
Europe, Middle East and Africa Technical Support:
Phone: 421 33 790 2910

ON Semiconductor Website: www.onsemi.com

Order Literature: <http://www.onsemi.com/orderlit>

For additional information, please contact your local Sales Representative