

# NLAS5157

## Ultra-Low 0.4 $\Omega$ SPDT Analog Switch

The NLAS5157 is Single Pole Double Throw (SPDT) switch designed for audio systems in portable applications. The NLAS5157 features Ultra-Low  $R_{ON}$  of 0.4  $\Omega$  typical at  $V_{CC} = 3.0$  V and 0.15  $\Omega$   $R_{ON}$  Flatness for +3.0 V supply across temperature. This device also has a broad  $V_{CC}$  operating range of 1.65 V to 4.5 V, ideal for battery-powered devices.

The NLAS5157 is protected on all pins with 8 kV Human Body Model ESD protection. This allows the device to be placed in a variety of locations, including near the interface, without risk of damage.

### Features

- $R_{ON} = 0.4 \Omega$  Typical @  $V_{CC} = 3.0$  V
- $V_{CC}$  Range: 1.65 V to 4.5 V
- 8 kV Human Body Model ESD on All Pins
- These are Pb-Free Devices

### Typical Applications

- Mobile Phones
- Portable Devices



ON Semiconductor®

<http://onsemi.com>



UDFN6  
CASE 517AQ

### MARKING DIAGRAM



A = Specific Device Code\*  
(Rotated 90°)  
M = Date Code

### PIN ASSIGNMENTS

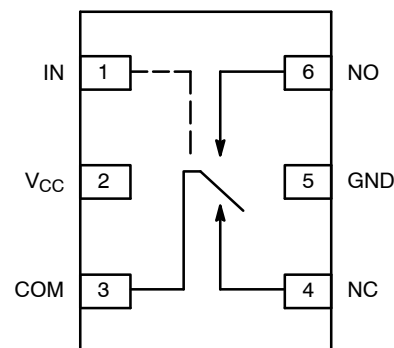

(Top View)

### ORDERING INFORMATION

Device	Package	Shipping†
NLAS5157MUTCG	UDFN6 (Pb-Free)	3000 / Tape & Reel

†For information on tape and reel specifications, including part orientation and tape sizes, please refer to our Tape and Reel Packaging Specifications Brochure, BRD8011/D.

# NLAS5157

## PIN DESCRIPTION

PIN #	Name	Direction	Description
1	IN	Input	Control Input Select Line
2	V <sub>CC</sub>	Power	Voltage Supply
3	COM	I/O	Common Signal Line
4	NC	I/O	Normally Closed Signal Line
5	GND	Power	Ground
6	NO	I/O	Normally Open Signal Line

## TRUTH TABLE

Control Input	Function
L	NC Connected to COM
H	NO Connected to COM

## MAXIMUM RATINGS

Symbol	Pins	Rating	Value	Condition	Unit
V <sub>CC</sub>	V <sub>CC</sub>	Positive DC Supply Voltage	0.5 to +5.5		V
V <sub>IS</sub>	NO, NC, or COM	Analog Signal Voltage	-0.5 to V <sub>CC</sub> + 0.5		V
V <sub>IN</sub>	IN	Control Input Voltage	-0.5 to +5.5		V
I <sub>IS_CON</sub>	NO, NC, or COM	Analog Signal Continuous Current	± 300	Closed Switch	mA
I <sub>IS_PK</sub>	NO, NC, or COM	Analog Signal Peak Current	± 500	10% Duty Cycle	mA
I <sub>IN</sub>	IN	Control Input Current	± 20		mA
T <sub>STG</sub>		Storage Temperature Range	-65 to 150		°C

Stresses exceeding Maximum Ratings may damage the device. Maximum Ratings are stress ratings only. Functional operation above the Recommended Operating Conditions is not implied. Extended exposure to stresses above the Recommended Operating Conditions may affect device reliability.

## RECOMMENDED OPERATING CONDITIONS

Symbol	Pins	Parameter	Value	Condition	Unit
V <sub>CC</sub>	V <sub>CC</sub>	Positive DC Supply Voltage	1.65 to 4.5		V
V <sub>IS</sub>	NO, NC, or COM	Analog Signal Voltage	GND to V <sub>CC</sub>		V
V <sub>IN</sub>	IN	Control Input Voltage (OVT) Overvoltage Tolerance	GND to 4.5		V
T <sub>A</sub>		Operating Temperature Range	-40 to +85		°C
t <sub>r</sub> , t <sub>f</sub>		Input Rise or Fall Time	20	V <sub>CC</sub> = 1.6 V – 2.7 V	ns/V
			10	V <sub>CC</sub> = 3.0 V – 4.5 V	

Minimum and maximum values are guaranteed through test or design across the **Recommended Operating Conditions**, where applicable. Typical values are listed for guidance only and are based on the particular conditions listed for each section, where applicable. These conditions are valid for all values found in the characteristics tables unless otherwise specified in the test conditions.

## ESD PROTECTION

Pins	Description	Minimum Voltage
All Pins	Human Body Model	7 kV

# NLAS5157

## DC ELECTRICAL CHARACTERISTICS

**CONTROL INPUT** (Typical: T = 25°C; V<sub>CC</sub> = 3.0 V)

Symbol	Pins	Parameter	Test Conditions	V <sub>CC</sub> (V)	-40°C to +85°C			Unit
					Min	Typ	Max	
V <sub>IH</sub>	IN	Control Input High		1.8 – 2.7 3.0 4.5	1.0 1.3 1.6			V
V <sub>IL</sub>	IN	Control Input Low		1.8 – 2.7 3.0 4.5			0.4 0.5 0.6	V
I <sub>IN</sub>	IN	Control Input Leakage	0 ≤ V <sub>IN</sub> ≤ V <sub>CC</sub>	4.5		±0.1	±0.5	μA

**SUPPLY CURRENT AND LEAKAGE** (Typical: T = 25°C; V<sub>CC</sub> = 3.0 V)

Symbol	Pins	Parameter	Test Conditions	V <sub>CC</sub> (V)	-40°C to +85°C			Unit
					Min	Typ	Max	
I <sub>NO/NC</sub> (OFF)	NC, NO	OFF State Leakage	V <sub>IN</sub> = V <sub>IL</sub> or V <sub>IH</sub> V <sub>NC/NO</sub> = 0.3 V V <sub>COM</sub> = 4.0 V	4.5		±10	±100	nA
I <sub>COM</sub> (ON)	COM	ON State Leakage	V <sub>IN</sub> = V <sub>IL</sub> or V <sub>IH</sub> V <sub>NO</sub> = 0.3 V or 4.0 V with V <sub>NC</sub> Floating or V <sub>NC</sub> = 0.3 V or 4.0 V with V <sub>NO</sub> Floating V <sub>COM</sub> = 0.3 V or 4.0 V	4.5		±20	±100	nA
I <sub>CC</sub>	V <sub>CC</sub>	Quiescent Supply	V <sub>IN</sub> and V <sub>IS</sub> = V <sub>CC</sub> or GND I <sub>D</sub> = 0 A	1.65 – 4.5		±0.1	±1.0	μA
I <sub>OFF</sub>	IN	Power Off Leakage	V <sub>IN</sub> = 4.5 V or GND	0		±0.5	±1.0	μA

**ON RESISTANCE** (Typical: T = 25°C; V<sub>CC</sub> = 3.0 V)

Symbol	Pins	Parameter	Test Conditions	V <sub>CC</sub> (V)	-40°C to +85°C			Unit
					Min	Typ	Max	
R <sub>ON</sub>	NO, NC COM	ON Resistance	I <sub>ON</sub> = -100 mA V <sub>IS</sub> = 0 to V <sub>CC</sub>	3.0 4.5		0.4 0.35	0.6 0.5	Ω
R <sub>FLAT</sub>	NO, NC COM	R <sub>ON</sub> Flatness	I <sub>ON</sub> = -100 mA V <sub>IS</sub> = 0 to V <sub>CC</sub>	3.0 4.5		0.12 0.15	0.16 0.17	Ω
ΔR <sub>ON</sub>	NO, NC COM	R <sub>ON</sub> Matching	I <sub>ON</sub> = -100 mA V <sub>IS</sub> = 0 to V <sub>CC</sub>	3.0 4.5		0.08 0.08	0.1 0.1	Ω

# NLAS5157

## AC ELECTRICAL CHARACTERISTICS

**TIMING/FREQUENCY** (Typical: T = 25°C; V<sub>CC</sub> = 3.0 V, R<sub>L</sub> = 50 Ω, C<sub>L</sub> = 35 pF, f = 1 MHz)

Symbol	Pins	Parameter	Test Conditions	V <sub>CC</sub> (V)	-40°C to +85°C			Unit
					Min	Typ	Max	
t <sub>ON</sub>	IN to NC or NO	Turn On Time		2.3 – 4.3		30	40	ns
t <sub>OFF</sub>	IN to NC or NO	Turn Off Time		2.3 – 4.53		18	25	ns
t <sub>BBM</sub>	IN to NC or NO	Break Before Make		3.0	2	15		ns
BW		-3dB Bandwidth	C <sub>L</sub> = 5 pF	1.65 – 4.5		36		MHz

**ISOLATION AND THD** (Typical: T = 25°C; V<sub>CC</sub> = 3.0 V, R<sub>L</sub> = 50 Ω, C<sub>L</sub> = 5 pF, f = 1 MHz)

Symbol	Pins	Parameter	Test Conditions	V <sub>CC</sub> (V)	-40°C to +85°C			Unit
					Min	Typ	Max	
Q		Charge Injection	V <sub>IN</sub> = V <sub>CC</sub> to GND R <sub>IS</sub> = 0 Ω, C <sub>L</sub> = 1.0 nF Q = C <sub>L</sub> - ΔV <sub>OUT</sub>	1.65 – 4.3		38		pC
THD		Total Harmonic Distortion	F <sub>IS</sub> = 20 Hz to 20 kHz R <sub>L</sub> = R <sub>gen</sub> = 600 Ω, C <sub>L</sub> = 1.0 pF V <sub>IS</sub> = 1.0 V <sub>PP</sub>	3.0		0.02		%
O <sub>IRR</sub>	NO	Off Isolation	V <sub>IN</sub> = 0 V <sub>NO</sub> or V <sub>NC</sub> (pk-pk) = 1.0 V	1.65 – 4.5		-54		dB
Xtalk	COM to COMy	Non-Adjacent Channel	V <sub>NO</sub> or V <sub>NC</sub> (pk-pk) = 1.0 V	1.65 – 4.5		-54		dB

**CAPACITANCE** (Typical: T = 25°C; V<sub>CC</sub> = 3.0 V, R<sub>L</sub> = 50 Ω, C<sub>L</sub> = 5 pF, f = 1 MHz)

Symbol	Pins	Parameter	Test Conditions	V <sub>CC</sub> (V)	-40°C to +85°C			Unit
					Min	Typ	Max	
C <sub>IN</sub>	IN	Control Input		0 V		3.5		pF
C <sub>ON</sub>	NC to COM	Through Switch	V <sub>IN</sub> = 0V	3.0 V		95		pF
C <sub>OFF</sub>	NC, NC	Unselected Port	V <sub>IS</sub> = 3.0V, V <sub>IN</sub> = 3.0 V	3.0 V		47		pF

TYPICAL CHARACTERISTICS

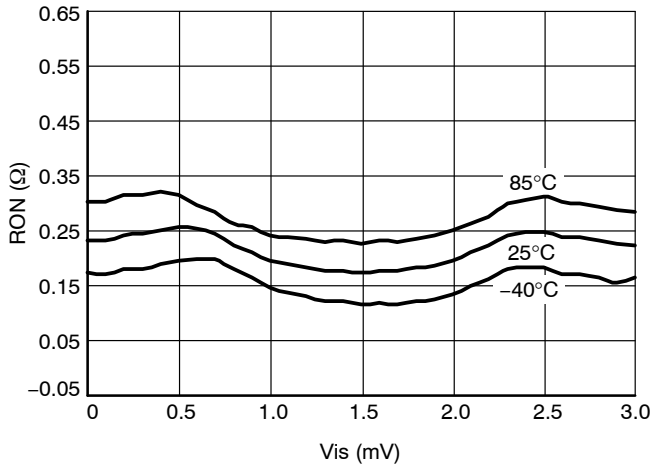

Figure 1. RON vs. Vin @ Vcc = 3.0 V, All Temps

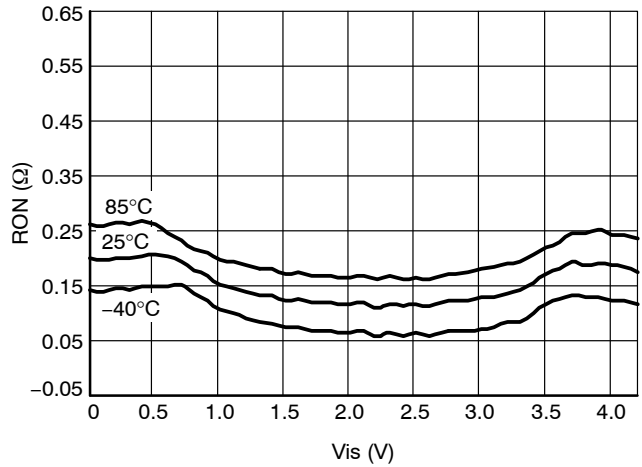

Figure 2. RON vs. Vin @ Vcc = 4.3 V, All Temps

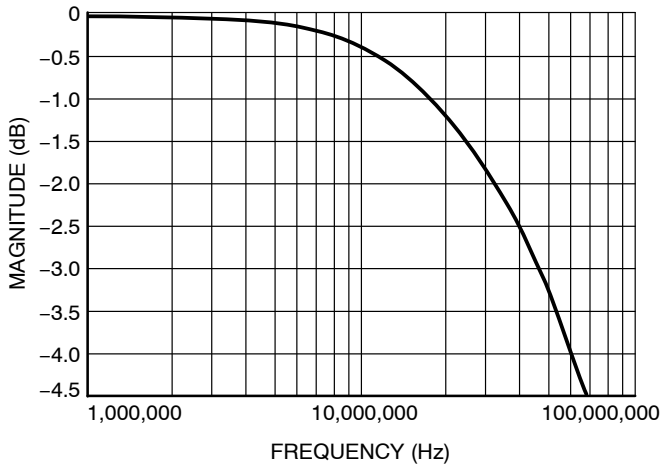

Figure 3. Bandwidth vs. Frequency

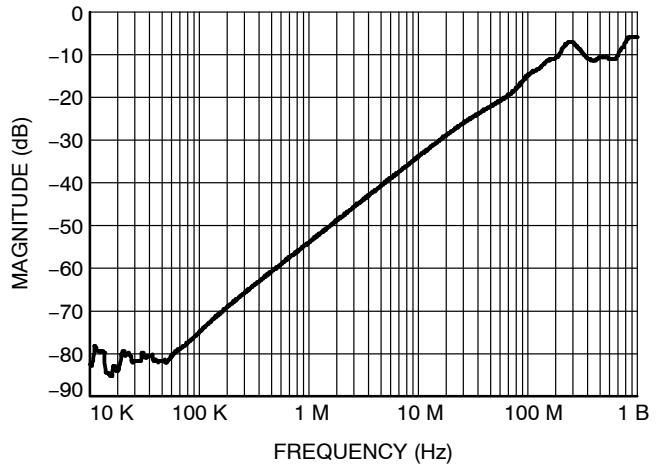

Figure 4. Cross-Talk vs. Frequency @ 25°C

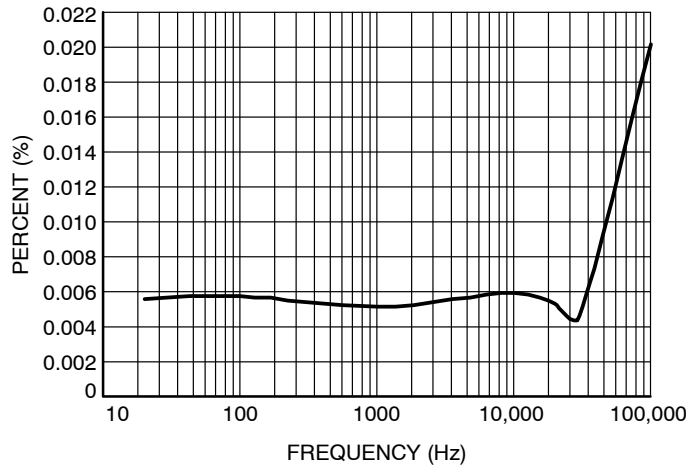

Figure 5. THD vs. Frequency @ Vin = 1 Vpp

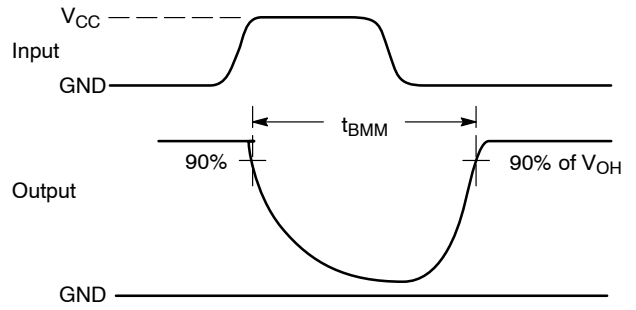
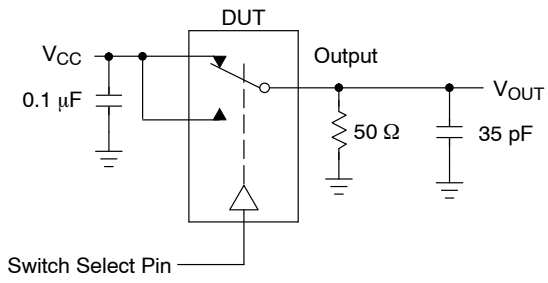

Figure 6.  $t_{BMM}$  (Time Break-Before-Make)

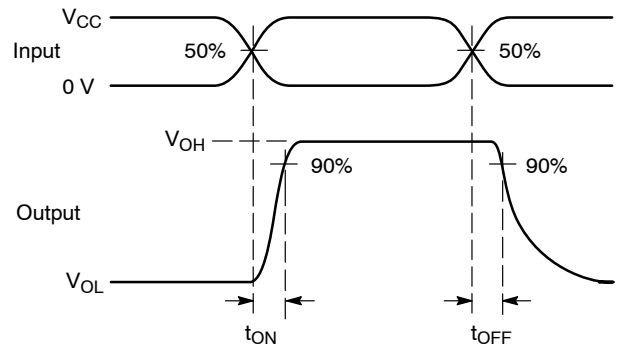
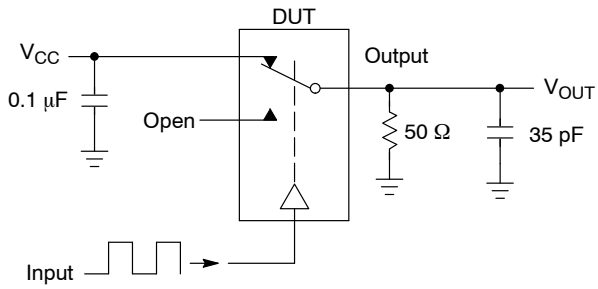

Figure 7.  $t_{ON}/t_{OFF}$

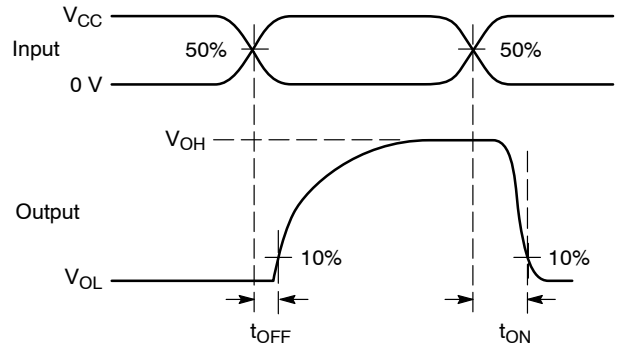
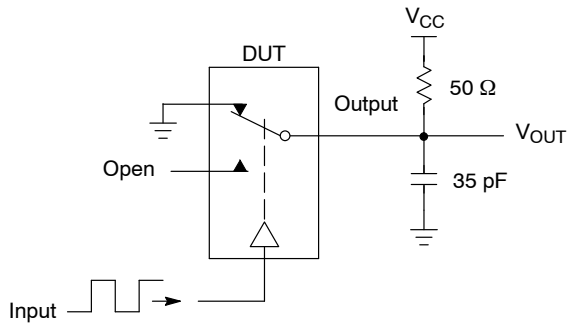
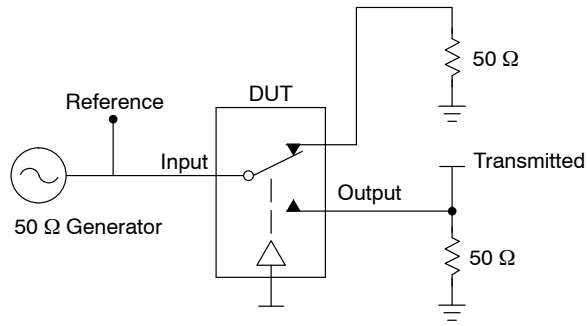

Figure 8.  $t_{ON}/t_{OFF}$

# NLAS5157



Channel switch control/s test socket is normalized. Off isolation is measured across an off channel. On loss is the bandwidth of an On switch.  $V_{ISO}$ , Bandwidth and  $V_{ONL}$  are independent of the input signal direction.

$$V_{ISO} = \text{Off Channel Isolation} = 20 \text{ Log} \left( \frac{V_{OUT}}{V_{IN}} \right) \text{ for } V_{IN} \text{ at } 100 \text{ kHz}$$

$$V_{ONL} = \text{On Channel Loss} = 20 \text{ Log} \left( \frac{V_{OUT}}{V_{IN}} \right) \text{ for } V_{IN} \text{ at } 100 \text{ kHz to } 50 \text{ MHz}$$

Bandwidth (BW) = the frequency 3 dB below  $V_{ONL}$

$V_{CT}$  = Use  $V_{ISO}$  setup and test to all other switch analog input/outputs terminated with 50 Ω

**Figure 9. Off Channel Isolation/On Channel Loss (BW)/Crosstalk (On Channel to Off Channel)/ $V_{ONL}$**

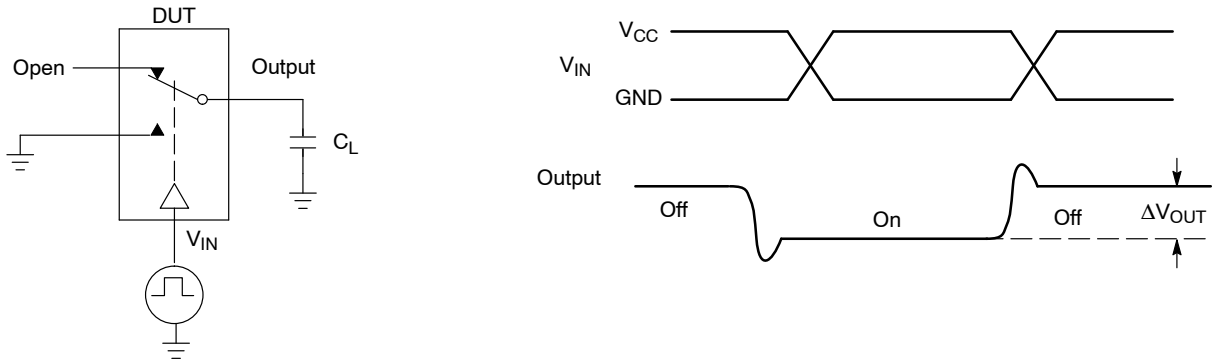
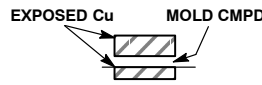
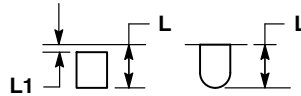
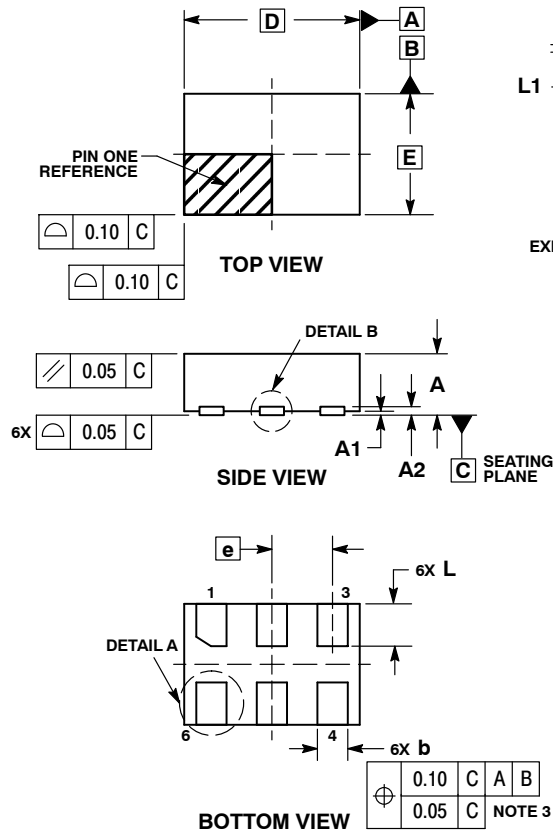

**Figure 10. Charge Injection: (Q)**

# NLAS5157

## PACKAGE DIMENSIONS

UDFN6, 1.45x1.0, 0.5P  
CASE 517AQ  
ISSUE O



**NOTES:**

1. DIMENSIONING AND TOLERANCING PER ASME Y14.5M, 1994.
2. CONTROLLING DIMENSION: MILLIMETERS.
3. DIMENSION b APPLIES TO PLATED TERMINAL AND IS MEASURED BETWEEN 0.15 AND 0.30 mm FROM THE TERMINAL TIP.

DIM	MILLIMETERS	
	MIN	MAX
A	0.45	0.55
A1	0.00	0.05
A2	0.07 REF	
b	0.20	0.30
D	1.45 BSC	
E	1.00 BSC	
e	0.50 BSC	
L	0.30	0.40
L1	---	0.15

### MOUNTING FOOTPRINT

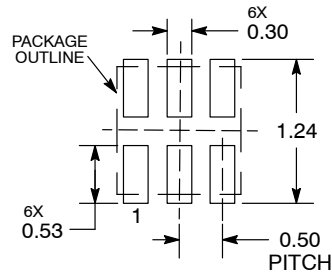

DIMENSIONS: MILLIMETERS

\*For additional information on our Pb-Free strategy and soldering details, please download the ON Semiconductor Soldering and Mounting Techniques Reference Manual, SOLDERRM/D.

ON Semiconductor and are registered trademarks of Semiconductor Components Industries, LLC (SCILLC). SCILLC owns the rights to a number of patents, trademarks, copyrights, trade secrets, and other intellectual property. A listing of SCILLC's product/patent coverage may be accessed at [www.onsemi.com/site/pdf/Patent-Marking.pdf](http://www.onsemi.com/site/pdf/Patent-Marking.pdf). SCILLC reserves the right to make changes without further notice to any products herein. SCILLC makes no warranty, representation or guarantee regarding the suitability of its products for any particular purpose, nor does SCILLC assume any liability arising out of the application or use of any product or circuit, and specifically disclaims any and all liability, including without limitation special, consequential or incidental damages. "Typical" parameters which may be provided in SCILLC data sheets and/or specifications can and do vary in different applications and actual performance may vary over time. All operating parameters, including "Typicals" must be validated for each customer application by customer's technical experts. SCILLC does not convey any license under its patent rights nor the rights of others. SCILLC products are not designed, intended, or authorized for use as components in systems intended for surgical implant into the body, or other applications intended to support or sustain life, or for any other application in which the failure of the SCILLC product could create a situation where personal injury or death may occur. Should Buyer purchase or use SCILLC products for any such unintended or unauthorized application, Buyer shall indemnify and hold SCILLC and its officers, employees, subsidiaries, affiliates, and distributors harmless against all claims, costs, damages, and expenses, and reasonable attorney fees arising out of, directly or indirectly, any claim of personal injury or death associated with such unintended or unauthorized use, even if such claim alleges that SCILLC was negligent regarding the design or manufacture of the part. SCILLC is an Equal Opportunity/Affirmative Action Employer. This literature is subject to all applicable copyright laws and is not for resale in any manner.

### PUBLICATION ORDERING INFORMATION

**LITERATURE FULFILLMENT:**  
Literature Distribution Center for ON Semiconductor  
P.O. Box 5163, Denver, Colorado 80217 USA  
Phone: 303-675-2175 or 800-344-3860 Toll Free USA/Canada  
Fax: 303-675-2176 or 800-344-3867 Toll Free USA/Canada  
Email: [orderlit@onsemi.com](mailto:orderlit@onsemi.com)

**N. American Technical Support:** 800-282-9855 Toll Free  
USA/Canada  
**Europe, Middle East and Africa Technical Support:**  
Phone: 421 33 790 2910  
**Japan Customer Focus Center**  
Phone: 81-3-5817-1050

**ON Semiconductor Website:** [www.onsemi.com](http://www.onsemi.com)  
**Order Literature:** <http://www.onsemi.com/orderlit>

For additional information, please contact your local Sales Representative