

NCV7441

Dual High Speed Low Power CAN Transceiver

The NCV7441, dual CAN transceiver offers two fully independent high-speed CAN transceivers which can be individually connected to two CAN protocol controllers. The CAN channels can be separately put to normal or to standby mode, in which remote wakeup detection from the bus is possible.

Due to the shared auxiliary circuitry and common package, this circuit version can replace two standard high-speed CAN transceivers while saving board space.

Features

- Compatible with the ISO 11898 Standard (ISO 11898-2, ISO 11898-5 and SAE J2284)
- Low Quiescent Current
- High Speed (up to 1 Mbps)
- Ideally Suited for 12 V and 24 V Industrial and Automotive Applications
- Extremely Low Current Standby Mode with Wakeup Via the Bus
- Low EME without Common-mode Choke
- No Disturbance of the Bus Lines with an Un-powered Node
- Predictable Behavior Under All Supply Circumstances
- Transmit Data (TxD) Dominant Time-out Function
- Thermal Protection
- Bus Pins Protected Against Transients in an Automotive Environment
- Power Down Mode in Which the Transmitter is Disabled
- Bus and V_{SPLIT} Pins Short Circuit Proof to Supply Voltage and Ground
- Input Logic Levels Compatible with 3.3 V Devices
- Up to 110 Nodes can be Connected to the Same Bus in Function of Topology
- Pb-Free Packages are Available

Typical Applications

- Automotive
- Industrial Networks



ON Semiconductor®

<http://onsemi.com>

MARKING DIAGRAM

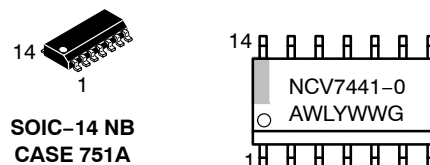

XXXXX = Specific Device Code
A = Assembly Location
WL = Wafer Lot
Y = Year
WW = Work Week
G = Pb-Free Package

PIN CONNECTIONS

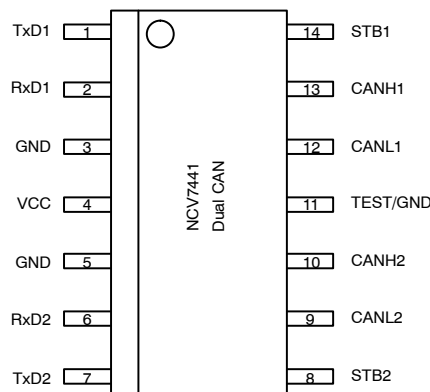

ORDERING INFORMATION

See detailed ordering and shipping information in the package dimensions section on page 9 of this data sheet.

NCV7441

BLOCK DIAGRAM

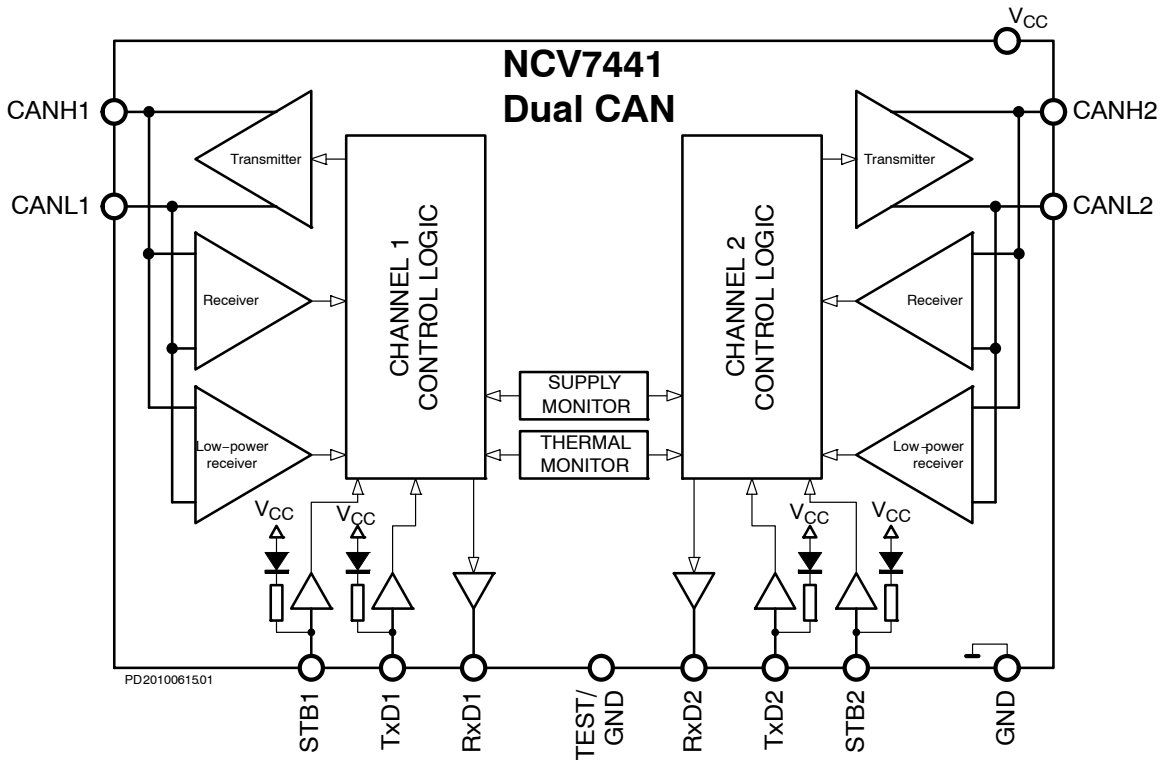

Figure 1. NCV7441 Dual CAN: Block Diagram

Table 1. PIN FUNCTION DESCRIPTION

Pin Number	Pin Name	Pin Type	Description
1	TxD1	digital input; internal pull-up	transmit data for the 1 st CAN channel in normal mode; ignored in standby mode
2	RxD1	digital output	received data from the 1 st CAN channel in normal mode; 1 st CAN channel remote wakeup indication in standby mode
3	GND	ground	ground connection
4	V _{CC}	supply input	5 V supply connection
5	GND	ground	ground connection
6	RxD2	digital output	received data from the 2 nd CAN channel; 2 nd CAN channel remote wakeup indication in standby mode
7	TxD2	digital input; internal pull-up	transmit data for the 2 nd CAN channel
8	STB2	digital input; internal pull-up	mode control input for the 2 nd CAN channel; STB2 = High puts the 2 nd CAN channel into standby mode
9	CANL2	high-voltage analog input/output	CANL-wire connection of the 2 nd CAN channel
10	CANH2	high-voltage analog input/output	CANH-wire connection of the 2 nd CAN channel
11	TEST / GND	test/ground	The pin is used for test purposes during device production. It's recommended to connect to ground in the end-application.
12	CANL1	high-voltage analog input/output	CANL-wire connection of the 1 st CAN channel
13	CANH1	high-voltage analog input/output	CANH-wire connection of the 1 st CAN channel
14	STB1	digital input; internal pull-up	mode control input for the 1 st CAN channel; STB1 = High puts the 1 st CAN channel into standby mode

NCV7441

TYPICAL APPLICATION DIAGRAM

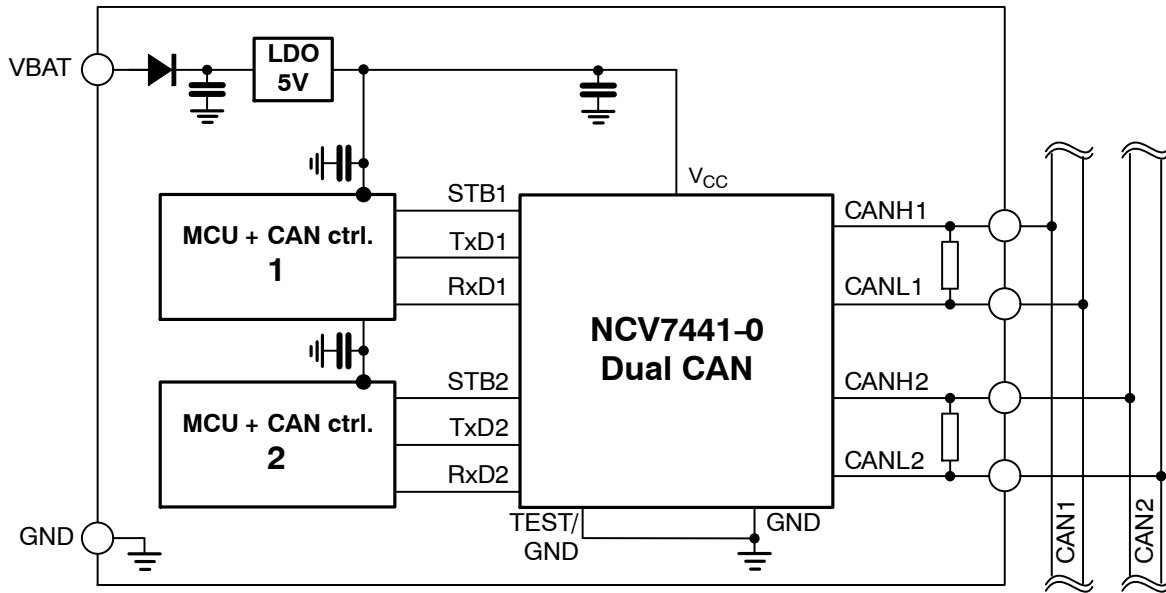

PD20100615.03

Figure 2. NCV7441 Dual CAN: Example Application Diagram

FUNCTIONAL DESCRIPTION

Dual CAN device behaves identically to two independent CAN transceivers. The representative signal dependencies are shown in Figure 4 and further functional description is given in Table 2.

Table 2. FUNCTIONAL DESCRIPTION

V _{CC}	STB1/2	TxD1/2	RxD1/2	Transceiver on CANH1/2/CANL1/2	Comment
< V _{CC_UV}	X	X	HZ	Deactivated; unbiased	The entire chip in under-voltage
> V _{CC_UV}	High	X	Low-power receiver output	Transmitter deactivated; Bus biased to GND through the input circuitry; Receiver monitoring CAN1/2 wakeup	CAN1/2 in standby mode
	Low	High	Indicates the signal received on CAN1/2	Recessive signal transmitted on CAN1/2; Bus biased to V _{CC} /2 through the input circuitry	CAN1/2 in normal mode
	Low	Low		Dominant signal transmitted on CAN1/2; Bus biased to V _{CC} /2 through the input circuitry	

NCV7441

If the main power supply V_{CC} (nominal 5 V) is above its under-voltage (V_{CC_UV}) level, each CAN channel can enter either normal mode (when the corresponding STB1/2 digital input is pulled Low) or standby mode (when the corresponding STB1/2 signal is left High):

- In the normal mode:
 - ◆ The bus transceiver is ready to transmit and receive CAN bus signals with the full CAN communication speed (up to 1 Mbps) and thus interconnect the CAN bus with the corresponding CAN controller through digital pins TxD1/2 and RxD1/2
 - ◆ The bus pins are internally biased to typically $V_{CC}/2$ through the input circuitry
 - ◆ TxD1/2 input pin is monitored by a timeout in order to prevent a permanent dominant being forced to the bus thus preventing other nodes from communicating. If TxD1/2 is Low for longer than $t_{cnt(timeout)}$, the transmitter switches back to recessive. Only when TxD1/2 returns to High, the timeout counter is reset and the transmitter is ready to transmit dominant symbols again. The TxD1/2 timeout protection is implemented individually for both CAN transceivers.
 - ◆ A common thermal monitoring circuit compares the circuit junction temperatures with threshold $T_{J(sd)}$. If the thermal shutdown level is exceeded, dominant transmission is disabled. The circuit remains biased and ready to transmit but the logical path from TxD1/2 pin(s) is blocked. The transmission is again enabled when the junction temperature decreases below the shutdown level and the TxD1/2 pin returns to the High level, thus avoiding thermal oscillations.
- In the standby mode:
 - ◆ The respective transmitter is disabled and the current consumption of the channel is fundamentally reduced. Only the low-power receiver on the channel remains active in order to detect potential CAN bus wakeups. The logical signal on TxD1/2 input is ignored.
 - ◆ The bus pins are biased to GND through the input circuitry
 - ◆ Digital output RxD1/2 signals the output of the low-power receiver and can be used as a wakeup signal in the application. A filtering time t_{dBUS} is applied between the bus activity and the RxD1/2 signal in order to ensure that only sufficiently long dominant signals on the bus will be propagated to the digital output. In addition, dominant bus signals are ignored in case they were present during normal-to-standby mode transition; in this way unwanted wakeups are avoided in case of permanent dominant failure on the bus. Example waveforms illustrating bus activity detection in standby mode are shown in Figure 3.

In order to ensure a safe device state, the digital inputs STB1/2 and TxD1/2 are connected through internal pull-up resistors to V_{CC} thus ensuring that both channels remain in standby mode and/or no dominant can be transmitted in case any of the digital inputs gets disconnected.

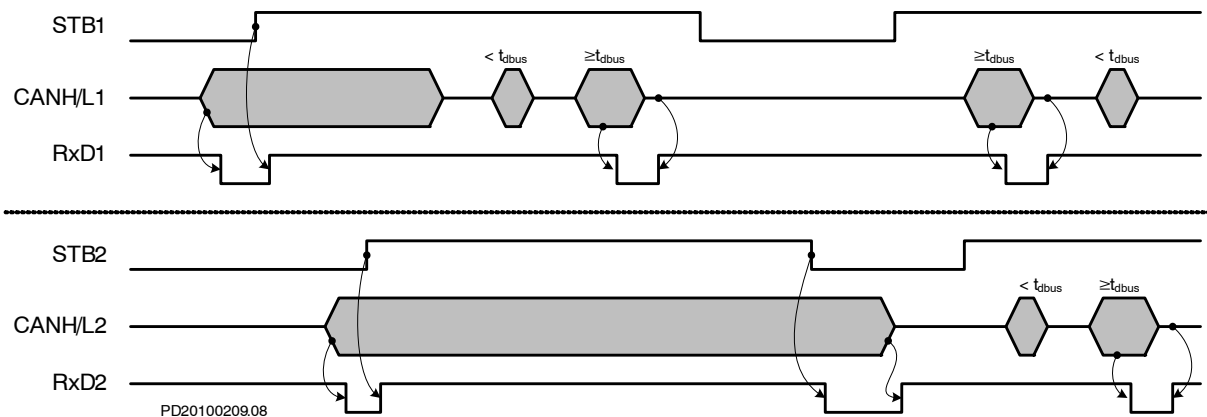

Figure 3. NCV7441 Dual CAN: Bus Activity Detection in Standby Mode

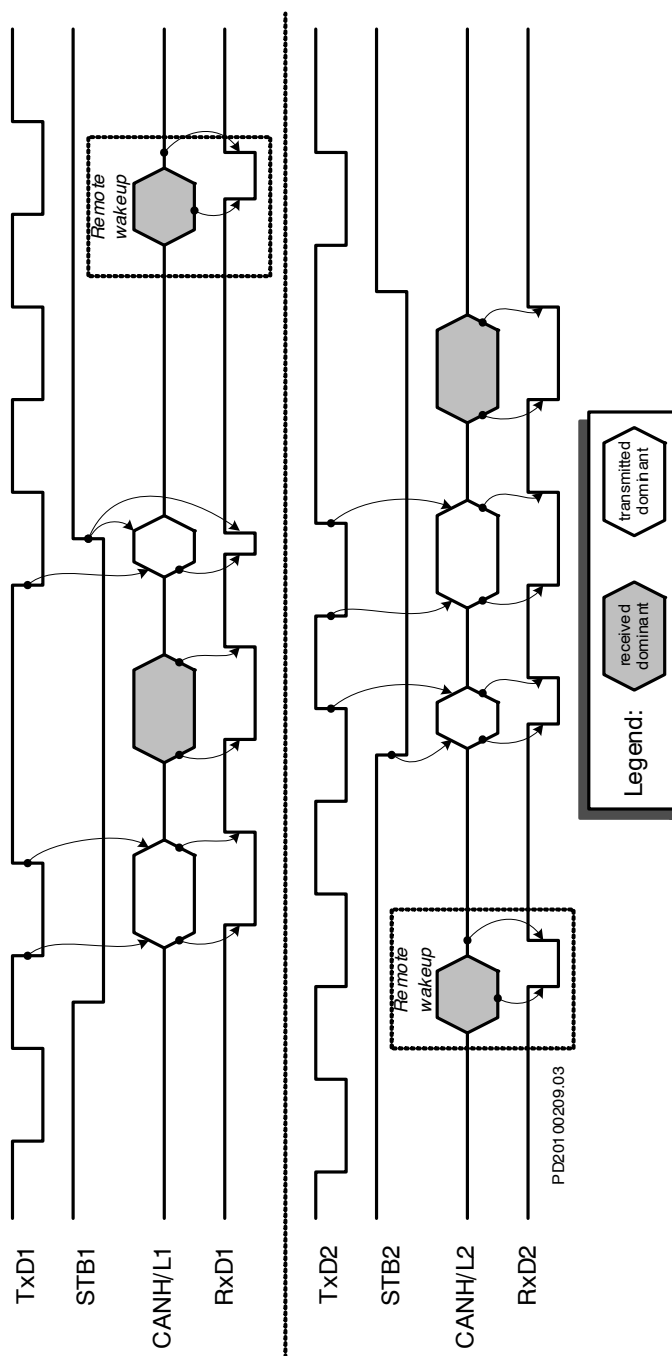

Figure 4. NCV7441 Dual CAN: Functional Graphs

Table 3. ABSOLUTE MAXIMUM RATINGS

Symbol	Parameter	Min	Max	Unit
V_{max_VCC}	Supply voltage	-0.3	6	V
V_{max_digIn}	Voltage at digital inputs. TxD1, TxD2, STB1, STB2	-0.3	6	V
V_{max_digOut}	Voltage at digital outputs. RxD1, RxD2, TEST/GND	-0.3	($V_{CC} + 0.3$)	V
$V_{max_CANH1/2}$	Voltage on CANH1/2 pin; no time limit	-50	+50	V
$V_{max_CANL1/2}$	Voltage on CANL1/2 pin ; no time limit	-50	+50	V
$V_{max_diffCAN}$	Absolute voltage difference between CAN pins: $ V_{(CANH1)} - V_{(CANL1)} $; $ V_{(CANH2)} - V_{(CANL2)} $	0	50	V
$T_{J(max)}$	Junction temperature	-40	170	°C
ESD	System ESD on CANH1/2 and CANL1/2 as per IEC 61000-4-2: 330 Ω / 150 pF	-8	8	kV
	Human body model on CANH1/2 and CANL1/2 as per JESD22-A114 / AEC-Q100-002	-8	8	kV
	Human body model on other pins as per JESD22-A114 / AEC-Q100-002	-4	4	kV
	Charge device model on all pins as per JESD22-C101 / AEC-Q100-011	-500	500	V

Stresses exceeding Maximum Ratings may damage the device. Maximum Ratings are stress ratings only. Functional operation above the Recommended Operating Conditions is not implied. Extended exposure to stresses above the Recommended Operating Conditions may affect device reliability.

Table 4. OPERATING RANGES

Symbol	Parameter	Min	Max	Unit
V_{op_VCC}	Supply voltage	4.75	5.25	V
V_{op_digIn}	Voltage at digital inputs. Dual CAN: TxD1, TxD2, STB1, STB2	0	V_{CC}	V
V_{op_digOut}	Voltage at digital outputs. RxD1, RxD2	0	V_{CC}	V
$V_{op_CANH1/2}$	Voltage on CANH1/2 pin Guaranteed receiver function	-35	35	V
$V_{op_CANL1/2}$	Voltage on CANL1/2 pin Guaranteed receiver function	35	35	V
$V_{op_diffCAN}$	Absolute voltage difference between CAN pins: $ V_{(CANH1)} - V_{(CANL1)} $; $ V_{(CANH2)} - V_{(CANL2)} $ Guaranteed receiver function	0	35	V
T_{J_op}	Junction temperature	-40	150	°C

NCV7441

Table 5. ELECTRICAL CHARACTERISTICS

The characteristics defined in this section are guaranteed within the operating ranges listed in Figure 4, unless stated otherwise. Positive currents flow into the respective pin.

Symbol	Parameter	Conditions	Min	Typ	Max	Unit
V_{CC} SUPPLY ELECTRICAL CHARACTERISTICS						
V _{CC_UV}	V _{CC} under voltage level		2.5	3.5	4.5	V
I _{VCC_stdby}	V _{CC} consumption	Both channels in standby mode; no wakeup detected; both buses recessive TxD1 = TxD2 = High		20	30	μA
I _{VCC_norm1}		One channel in normal mode; TxD1 = TxD2 = High	3	5	11	mA
I _{VCC_norm2}		Both channels in normal mode; TxD1 = TxD2 = High	6	10	20	mA
DIGITAL INPUTS ELECTRICAL CHARACTERISTICS – PINS TxD1, TxD2						
V _{TXX_L}	Low level input voltage		-0.3		0.8	V
V _{TXX_H}	High level input voltage		2		V _{CC} + 0.3	V
I _{TXX_L}	Low level input current	V _{CC} = 5 V V _(TXX) = GND	-75	-200	-350	μA
I _{TXX_H}	High level input current	V _{CC} = 0 ... 5.25 V V _(TXX) = 5 V	-0.5		0.5	μA
DIGITAL INPUTS ELECTRICAL CHARACTERISTICS – PINS STB1, STB2						
V _{STBX_L}	Low level input voltage		-0.3		0.8	V
V _{STBX_H}	High level input voltage		2		V _{CC} + 0.3	V
I _{STBX_L}	Low level input current	V _{CC} = 5 V V _(STBX) = GND	-1	-4	-10	μA
I _{STBX_H}	High level input current	V _{CC} = 0 ... 5.25 V V _(STBX) = 5 V	-0.5		0.5	μA
DIGITAL OUTPUTS ELECTRICAL CHARACTERISTICS – PINS RxD1, RxD2						
I _{digOut_L}	Output current at Low output level	V _(digOut) = 0.4 V	2	6	12	mA
I _{digOut_H}	Output current at High output level	at least one channel enabled V _(digOut) = V _{CC} - 0.4 V	-0.1	-0.4	-1	mA
V _{digOut_stdby}	Output level in standby mode	both channels in standby; I _(digOut) = -100 μA	V _{CC} - 1.1	V _{CC} - 0.7	V _{CC} - 0.4	V
I _{digOut_HZ}	Output current in High-impedance state	during V _{CC} undervoltage; V _(digOut) = 0 V ... V _{CC}	-2	0	2	μA
CAN TRANSMITTER CHARACTERISTICS						
V _{o(reces)(CANH1/2)}	recessive bus voltage at pin CANH1/2	V _{TxD1/2} = V _{CC} ; no load on the bus, normal mode	2.0	2.5	3.0	V
		no load on the bus; standby mode	-0.1	0	0.1	
V _{o(reces)(CANL1/2)}	recessive bus voltage at pin CANL1/2	V _{TxD1/2} = V _{CC} ; no load on the bus, normal mode	2.0	2.5	3.0	V
		no load on the bus; standby mode	-0.1	0	0.1	
I _{o(reces)(CANH1/2)}	recessive output current at pin CANH1/2	-35 V < V _{CANH1/2} < 35 V; 0 V < V _{CC} < 5.25 V	-2.5	-	2.5	mA
I _{o(reces)(CANL1/2)}	recessive output current at pin CANL1/2	-35 V < V _{CANL1/2} < 35 V; 0 V < V _{CC} < 5.25 V	-2.5	-	2.5	mA

Table 5. ELECTRICAL CHARACTERISTICS

The characteristics defined in this section are guaranteed within the operating ranges listed in Figure 4, unless stated otherwise. Positive currents flow into the respective pin.

Symbol	Parameter	Conditions	Min	Typ	Max	Unit
CAN TRANSMITTER CHARACTERISTICS						
$V_{o(dom)(CANH1/2)}$	dominant output voltage at pin CANH1/2	$V_{TXD1/2} = 0\text{ V}$	3.0	3.6	4.25	V
$V_{o(dom)(CANL1/2)}$	dominant output voltage at pin CANL1/2	$V_{TXD1/2} = 0\text{ V}$	0.5	1.4	1.75	V
$V_{o(dif)(BUS_dom)}$	differential bus output voltage ($V_{CANH1/2} - V_{CANL1/2}$)	$V_{TXD1/2} = 0\text{ V}$, dominant; bus differential load: $42.5\ \Omega < R_L < 60\ \Omega$	1.5	2.25	3.0	V
$V_{o(dif)(BUS_rec)}$	differential bus output voltage ($V_{CANH1/2} - V_{CANL1/2}$)	$V_{TXD1/2} = V_{CC}$ Recessive, no load on the bus	-120	0	50	mV
$I_{o(SC)(CANH1/2)}$	short-circuit output current at pin CANH1/2	$V_{CANH1/2} = 0\text{ V}$, $V_{TXD1/2} = 0\text{ V}$	-100	-70	-45	mA
$I_{o(SC)(CANL1/2)}$	short-circuit output current at pin CANL1/2	$V_{CANL1/2} = 36\text{ V}$, $V_{TXD1/2} = 0\text{ V}$	45	70	100	mA
CAN RECEIVER AND CAN PINS ELECTRICAL CHARACTERISTICS						
$V_{i(dif)(th)}$	Differential receiver threshold voltage	normal mode $-12\text{ V} < V_{CANH1/2} < 12\text{ V}$ $-12\text{ V} < V_{CANL1/2} < 12\text{ V}$	0.5	0.7	0.9	V
		standby mode $-12\text{ V} < V_{CANH1/2} < 12\text{ V}$ $-12\text{ V} < V_{CANL1/2} < 12\text{ V}$	0.4	0.8	1.15	
$V_{ihcm(dif)(th)}$	Differential receiver threshold voltage for high common mode	normal mode $-35\text{ V} < V_{CANH1/2} < 35\text{ V}$ $-35\text{ V} < V_{CANL1/2} < 35\text{ V}$	0.4	0.7	1	V
$V_{ihcm(dif)(hys)}$	Differential receiver input voltage hysteresis for high common mode	normal mode $-35\text{ V} < V_{CANH1/2} < 35\text{ V}$ $-35\text{ V} < V_{CANL1/2} < 35\text{ V}$	20	70	100	mV
$R_{i(cm)CANH1/2}$	Common mode input resistance at pin CANH1/2		15	26	37	k Ω
$R_{i(cm)CANL1/2}$	Common mode input resistance at pin CANL1/2		15	26	37	k Ω
$R_{i(cm)(m)}$	Matching between pin CANH1/2 and pin CANL1/2 common mode input resistance	$V_{CANH1/2} = V_{CANL1/2}$	-3	0	3	%
$R_{i(dif)}$	Differential input resistance		25	50	75	k Ω
$C_{I(CANH1/2)}$	input capacitance at pin CANH1/2	$V_{TXD1/2} = V_{CC}$ not tested in production	-	7.5	20	pF
$C_{I(CANL1/2)}$	input capacitance at pin CANL1/2	$V_{TXD1/2} = V_{CC}$ not tested in production	-	7.5	20	pF
$C_{I(dif)}$	differential input capacitance	$V_{TXD1/2} = V_{CC}$ not tested in production	-	3.75	10	pF
$I_{L(CANH1/2)}$	Input leakage current to pin CANH1/2	$V_{CC} = 0\text{ V}$; $V_{CANL1/2} = V_{CANH1/2} = 5\text{ V}$	-10	0	10	μA
$I_{L(CANL1/2)}$	Input leakage current to pin CANL1/2	$V_{CC} = 0\text{ V}$; $V_{CANL1/2} = V_{CANH1/2} = 5\text{ V}$	-10	0	10	μA
THERMAL MONITORING ELECTRICAL CHARACTERISTICS						
$T_{J(sd)}$	Thermal shutdown threshold	Junction temperature rising	150		185	$^{\circ}\text{C}$
		Junction temperature falling	145			$^{\circ}\text{C}$

NCV7441

Table 5. ELECTRICAL CHARACTERISTICS

The characteristics defined in this section are guaranteed within the operating ranges listed in Figure 4, unless stated otherwise. Positive currents flow into the respective pin.

Symbol	Parameter	Conditions	Min	Typ	Max	Unit
DYNAMIC ELECTRICAL CHARACTERISTICS						
$t_{d(TXD1/2-BUSon)}$	delay TxD1/2 to CAN1/2 bus active	bus differential load 100 pF/60 Ω	20	85	120	ns
$t_{d(TXD1/2-BUSoff)}$	delay TxD1/2 to CAN1/2 bus inactive	bus differential load 100 pF/60 Ω		30	105	ns
$t_{d(BUSon-RXD1/2)}$	delay CAN1/2 bus active to RxD1/2	$C_{RxD1/2} = 15$ pF	25	55	105	ns
$t_{d(BUSoff-RX0)}$	delay CAN1/2 bus inactive to RxD1/2	$C_{RxD1/2} = 15$ pF	30	100	105	ns
$t_{dPD(TXD1/2-RXD1/2)dr}$	propagation delay TxD1/2 to RxD1/2; dominant-to-recessive	bus differential load 100 pF/60 Ω	30		245	ns
$t_{dPD(TXD1/2-RXD1/2)rd}$	propagation delay TxD1/2 to RxD1/2; recessive-to-dominant	bus differential load 100 pF/60 Ω	75		230	ns
t_{dBUS}	low-power receiver filtering time	standby mode $V_{dif(dom)} > 1.4$ V	0.5	2.5	5	μ s
		standby mode $V_{dif(dom)} > 1.2$ V	0.5	3	5.8	
t_{dWAKE}	delay to flag bus wakeup; time from CAN bus dominant start to RxDx falling edge	standby mode; dominant longer than t_{dBUS}			10	μ s
$t_{d(nrm-stb)}$	transition delay from STB1/2 rising edge to CAN1/2 standby mode				10	μ s
$t_{d(stb-nrm)}$	transition delay from STB1/2 falling edge to CAN1/2 normal mode				10	μ s
$t_{cnt(timeout)}$	TxD1/2 dominant time out	$V_{TXD1/2} = 0$ V	300	650	1000	μ s
I_{digOut_HZ}	Output current in High-impedance state	pins RxD1,2 during V_{CC} under-voltage; $V_{(digOut)} = 0$ V ... V_{CC}	-2	0	2	μ A

ORDERING INFORMATION

Device	Description	Temperature Range	Package	Shipping [†]
NCV7441D20G	Dual HS-CAN Transceiver	-40°C to 125°C	SOIC-14 (Pb-Free)	55 Tube / Tray
NCV7441D20R2G				3000 / Tape & Reel

[†]For information on tape and reel specifications, including part orientation and tape sizes, please refer to our Tape and Reel Packaging Specifications Brochure, BRD8011/D.

NCV7441

PACKAGE DIMENSIONS

SOIC-14 NB
CASE 751A-03
ISSUE K

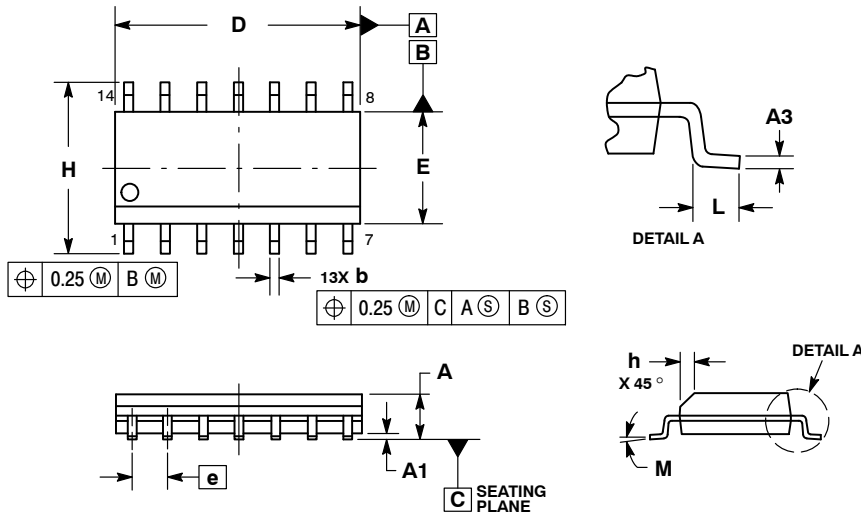

NOTES:

1. DIMENSIONING AND TOLERANCING PER ASME Y14.5M, 1994.
2. CONTROLLING DIMENSION: MILLIMETERS.
3. DIMENSION *b* DOES NOT INCLUDE DAMBAR PROTRUSION. ALLOWABLE PROTRUSION SHALL BE 0.13 TOTAL IN EXCESS OF AT MAXIMUM MATERIAL CONDITION.
4. DIMENSIONS D AND E DO NOT INCLUDE MOLD PROTRUSIONS.
5. MAXIMUM MOLD PROTRUSION 0.15 PER SIDE.

DIM	MILLIMETERS		INCHES	
	MIN	MAX	MIN	MAX
A	1.35	1.75	0.054	0.068
A1	0.10	0.25	0.004	0.010
A3	0.19	0.25	0.008	0.010
b	0.35	0.49	0.014	0.019
D	8.55	8.75	0.337	0.344
E	3.80	4.00	0.150	0.157
e	1.27 BSC		0.050 BSC	
H	5.80	6.20	0.228	0.244
h	0.25	0.50	0.010	0.019
L	0.40	1.25	0.016	0.049
M	0°	7°	0°	7°

SOLDERING FOOTPRINT*

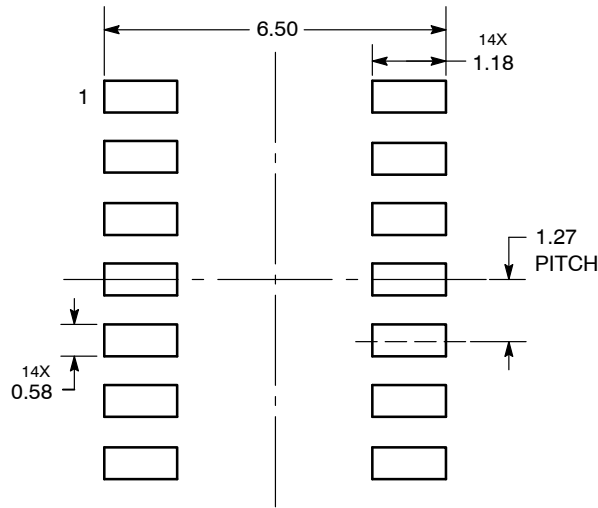

DIMENSIONS: MILLIMETERS

*For additional information on our Pb-Free strategy and soldering details, please download the ON Semiconductor Soldering and Mounting Techniques Reference Manual, SOLDERRM/D.

ON Semiconductor and are registered trademarks of Semiconductor Components Industries, LLC (SCILLC). SCILLC reserves the right to make changes without further notice to any products herein. SCILLC makes no warranty, representation or guarantee regarding the suitability of its products for any particular purpose, nor does SCILLC assume any liability arising out of the application or use of any product or circuit, and specifically disclaims any and all liability, including without limitation special, consequential or incidental damages. "Typical" parameters which may be provided in SCILLC data sheets and/or specifications can and do vary in different applications and actual performance may vary over time. All operating parameters, including "Typicals" must be validated for each customer application by customer's technical experts. SCILLC does not convey any license under its patent rights nor the rights of others. SCILLC products are not designed, intended, or authorized for use as components in systems intended for surgical implant into the body, or other applications intended to support or sustain life, or for any other application in which the failure of the SCILLC product could create a situation where personal injury or death may occur. Should Buyer purchase or use SCILLC products for any such unintended or unauthorized application, Buyer shall indemnify and hold SCILLC and its officers, employees, subsidiaries, affiliates, and distributors harmless against all claims, costs, damages, and expenses, and reasonable attorney fees arising out of, directly or indirectly, any claim of personal injury or death associated with such unintended or unauthorized use, even if such claim alleges that SCILLC was negligent regarding the design or manufacture of the part. SCILLC is an Equal Opportunity/Affirmative Action Employer. This literature is subject to all applicable copyright laws and is not for resale in any manner.

PUBLICATION ORDERING INFORMATION

LITERATURE FULFILLMENT:
Literature Distribution Center for ON Semiconductor
P.O. Box 5163, Denver, Colorado 80217 USA
Phone: 303-675-2175 or 800-344-3860 Toll Free USA/Canada
Fax: 303-675-2176 or 800-344-3867 Toll Free USA/Canada
Email: orderlit@onsemi.com

N. American Technical Support: 800-282-9855 Toll Free USA/Canada
Europe, Middle East and Africa Technical Support:
Phone: 421 33 790 2910
Japan Customer Focus Center
Phone: 81-3-5773-3850

ON Semiconductor Website: www.onsemi.com
Order Literature: <http://www.onsemi.com/orderlit>
For additional information, please contact your local Sales Representative