

# 8/7/6/5/4/3/2/1 Multi-Phase Buck Controller with PWM\_VID and I<sup>2</sup>C Interface



ON Semiconductor®

[www.onsemi.com](http://www.onsemi.com)

## NCP81610

### Description

The NCP81610 is a multiphase synchronous controller optimized for new generation computing and graphics processors. The device is capable of driving up to 8 phases and incorporates differential voltage and phase current sensing, adaptive voltage positioning and PWM\_VID interface to provide and accurately regulated power for computer or graphic controllers. The integrated power saving interface (PSI) allows for the processors to set the controller in one of three modes, i.e. all phases on, dynamic phases shedding or fixed low phase count mode, to obtain high efficiency in light-load conditions. The dual edge PWM multiphase architecture ensures fast transient response and good dynamic current balance.

### Features

- Compliant with NVIDIA OVR4i+ Specifications
- Supports up to 8 Phases
- 2.8 V to 20 V Supply Voltage Range:
- 250 kHz to 1.2 MHz Switching Frequency (8 Phase)
- Power Good Output
- Under Voltage Protection (UVP)
- Over Voltage Protection (OVP)
- Per Phase Over Current Limiting (OCL)
- System Over Current Protection (OCP)
- Startup into Pre-Charged Loads while Avoiding False OVP
- Configurable Load Line
- High Performance Operational Error Amplifier
- True Differential Current Balancing Sense Amplifiers for Each Phase
- Phase-to-Phase Dynamic Current Balancing
- Current Mode Dual Edge Modulation for Fast Initial Response to Transient Loading
- Power Saving Interface (PSI)
- Automatic Phase Shedding with User Settable Thresholds
- PWM\_VID and I<sup>2</sup>C Control Interface
- Compact 40 Pin QFN Package (5 x 5 mm Body, 0.4 mm Pitch)
- These Devices are Pb-Free and are RoHS Compliant

### Typical Applications

- GPU and CPU Power
- Graphic Cards
- Desktop and Notebook Applications
- Docking Stations
- Power Banks

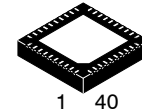

QFN40 5x5, 0.4P  
CASE 485CR

### MARKING DIAGRAM

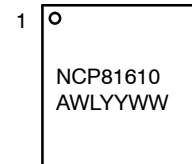

NCP81610 = Device Code  
A = Assembly Site  
WL = Wafer Lot Number  
YY = Year of Production, Last Two Numbers  
WW = Work Week Number

### PIN CONNECTIONS

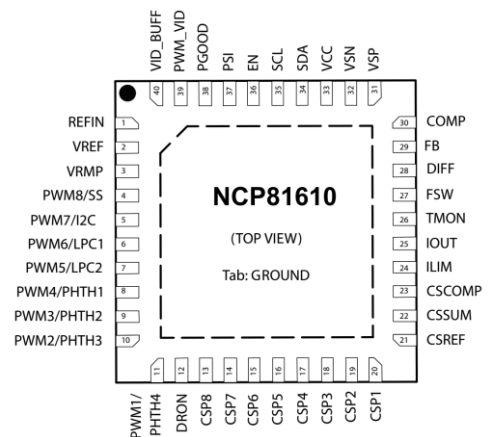

### ORDERING INFORMATION

| Device        | Package         | Shipping <sup>†</sup> |
|---------------|-----------------|-----------------------|
| NCP81610MNTXG | QFN40 (Pb-Free) | 5000 / Tape & Reel    |

<sup>†</sup>For information on tape and reel specifications, including part orientation and tape sizes, please refer to our Tape and Reel Packaging Specification Brochure, BRD8011/D.



# NCP81610

## PIN DESCRIPTION

| Pin No. | Pin Name   | Pin Type | Description  |
|---------|------------|----------|--|
| 1       | REFIN      | I        | Reference voltage input for output voltage regulation.   |
| 2       | VREF       | O        | 2.0 V output reference voltage. A 10 nF ceramic capacitor is required to connect this pin to ground.   |
| 3       | VRMP       | I        | Feed-forward input of VIN for the ramp slope compensation.   |
| 4       | PWM8/SS    | I/O      | PWM 8 output / Soft Start setting. During startup it is used to program the soft start time with a resistor to ground.   |
| 5       | PWM7/I2C   | I/O      | PWM 7 output / I <sup>2</sup> C address. During startup it is used to program I <sup>2</sup> C address with a resistor to ground.                                |
| 6       | PWM6/LPC1  | I/O      | PWM 6 output / Low phase count 1. During startup it is used to program the warm boot-up power zone (PSI set low) with a resistor to ground.                      |
| 7       | PWM5/LPC2  | I/O      | PWM 5 output / Low phase count 2. During startup it is used to program the cold boot-up power zone (PSI set low) with a resistor to ground.                      |
| 8       | PWM4/PHTH1 | I/O      | PWM 4 output / Phase Shedding Threshold 1. During startup it is used to program the phase shedding threshold 1 (PSI set to mid state) with a resistor to ground. |
| 9       | PWM3/PHTH2 | I/O      | PWM 3 output / Phase Shedding Threshold 2. During startup it is used to program the phase shedding threshold 2 (PSI set to mid state) with a resistor to ground. |
| 10      | PWM2/PHTH3 | I/O      | PWM 2 output / Phase Shedding Threshold 3. During startup it is used to program the phase shedding threshold 3 (PSI set to mid state) with a resistor to ground. |
| 11      | PWM1/PHTH4 | I/O      | PWM 1 output / Phase Shedding Threshold 4. During startup it is used to program the phase shedding threshold 4 (PSI set to mid state) with a resistor to ground. |
| 12      | DRON       | I/O      | Bidirectional gate driver enable for external drivers.   |
| 13      | CSP8       | I        | Non-inverting input to current balance sense amplifier for phase 8. Pull-up to VCC with a 2 kΩ resistor to disable the PWM8 output.                              |
| 14      | CSP7       | I        | Non-inverting input to current balance sense amplifier for phase 7. Pull-up to VCC with a 2 kΩ resistor to disable the PWM7 output.                              |
| 15      | CSP6       | I        | Non-inverting input to current balance sense amplifier for phase 6. Pull-up to VCC with a 2 kΩ resistor to disable the PWM6 output.                              |
| 16      | CSP5       | I        | Non-inverting input to current balance sense amplifier for phase 5. Pull-up to VCC with a 2 kΩ resistor to disable the PWM5 output.                              |
| 17      | CSP4       | I        | Non-inverting input to current balance sense amplifier for phase 4. Pull-up to VCC with a 2 kΩ resistor to disable the PWM4 output.                              |
| 18      | CSP3       | I        | Non-inverting input to current balance sense amplifier for phase 3. Pull-up to VCC with a 2 kΩ resistor to disable the PWM3 output.                              |
| 19      | CSP2       | I        | Non-inverting input to current balance sense amplifier for phase 2. Pull-up to VCC with a 2 kΩ resistor to disable the PWM2 output.                              |
| 20      | CSP1       | I        | Non-inverting input to current balance sense amplifier for phase 1. Pull-up to VCC with a 2 kΩ resistor to disable the PWM1 output.                              |
| 21      | CSREF      | I        | Total output current sense amplifier reference voltage input.  |
| 22      | CSSUM      | I        | Inverting input of total current sense amplifier.  |
| 23      | CSCOMP     | O        | Output of total current sense amplifier.   |
| 24      | ILIM       | I/O      | Over current limit (OCL) threshold setting input. The threshold is set by a shunt resistor to the ground.  |
| 25      | IOUT       | O        | Total output current. A resistor to GND is required to provide a voltage drop of 2V at the maximum output current.   |
| 26      | TMON       | I        | DRMOS temperature monitoring.  |
| 27      | FSW        | I        | Resistor to ground from this pin sets the operating frequency of the regulator.  |
| 28      | DIFF       | O        | Output of the regulators differential remote sense amplifier.  |
| 29      | FB         | I        | Error amplifier inverting (feedback) input.  |
| 30      | COMP       | O        | Output of the error amplifier and the inverting input of the PWM comparator.   |

# NCP81610

## PIN DESCRIPTION (continued)

| Pin No. | Pin Name | Pin Type | Description  |
|---------|----------|----------|--|
| 31      | VSP      | I        | Differential Output Voltage Sense Positive terminal.   |
| 32      | VSN      | I        | Differential Output Voltage Sense Negative terminal.   |
| 33      | VCC      | I        | Power for the internal control circuits. A 1 $\mu$ F decoupling capacitor is required from this pin to ground. |
| 34      | SDA      | I/O      | Serial Data bi-directional pin, requires pull-up resistor to VCC.  |
| 35      | SCL      | I        | Serial Bus clock pin, requires pull-up resistor to VCC.  |
| 36      | EN       | I        | Logic input. Logic high enables regulator output logic low disables regulator output.                          |
| 37      | PSI      | I        | Power Saving Interface control pin. This pin can be set low, high or left floating.                            |
| 38      | PGOOD    | O        | Open Drain power good indicator.   |
| 39      | PWM_VID  | I        | PWM_VID buffer input.  |
| 40      | VID_BUFF | O        | PWM_VID pulse output from internal buffer.   |
| 41      | AGND     | GND      | Analog ground and thermal pad, connected to system ground.   |

## MAXIMUM RATINGS

| Pin Symbol       | Rating  | Min               | Typ | Max     | Unit |
|------------------|---|-------------------|-----|---------|------|
| VSN              | Pin Voltage Range (Note 1)  | GND-0.3           | -   | GND+0.3 | V    |
| VCC              |   | -0.3              | -   | 6.5     | V    |
| VRMP             |   | -0.3              | -   | 25      | V    |
| PWM_VID          |   | -0.3 (-2, <50 ns) | -   | VCC+0.3 | V    |
| All other pins   |   | -0.3              | -   | VCC+0.3 | V    |
| COMP             | Pin Current range   | -2                | -   | 2       | mA   |
| CSCOMP           |   |                   |     |         |      |
| DIFF             |   |                   |     |         |      |
| PGOOD            |   |                   |     |         |      |
| VSN              |   | -1                | -   | 1       | mA   |
| MSL              | Moisture Sensitivity Level  | -                 | 1   | -       | -    |
| T <sub>SLD</sub> | Lead Temperature Soldering<br>Reflow (SMD Styles Only), Pb-Free Versions (Note 2) | -                 | 260 | -       | °C   |

Stresses exceeding those listed in the Maximum Ratings table may damage the device. If any of these limits are exceeded, device functionality should not be assumed, damage may occur and reliability may be affected.

- All signals referenced to GND unless noted otherwise
- For information, please refer to our Soldering and Mounting Techniques Reference Manual, SOLDERRM/D

## THERMAL CHARACTERISTICS

| Symbol           | Rating  | Min | Typ | Max | Unit |
|------------------|---|-----|-----|-----|------|
| R <sub>θJA</sub> | Thermal Characteristics, QFN40, 5 x 5 mm)<br>Thermal Resistance, Junction-to-Air (Note 1) | -   | 68  | -   | °C/W |
| T <sub>J</sub>   | Operating Junction Temperature Range (Note 2)   | -40 | -   | 125 | °C   |
| T <sub>A</sub>   | Operating Ambient Temperature Range   | -10 | -   | 100 | °C   |
| T <sub>STG</sub> | Maximum Storage Temperature Range   | -55 | -   | 150 | °C   |

<sup>1</sup> JESD 51-5 (1S2P Direct-Attach Method) with 0 LFM )

<sup>2</sup> JESD 51-7 (1S2P Direct-Attach Method) with 0 LFM )

# NCP81610

**ELECTRICAL CHARACTERISTICS** ( $-10^{\circ}\text{C} < T_A < 100^{\circ}\text{C}$ ;  $4.6\text{ V} < V_{\text{CC}} < 5.4\text{ V}$ ;  $C_{\text{VCC}} = 0.1\ \mu\text{F}$  unless otherwise noted)

| Symbol | Parameter | Test Conditions | Min | Typ | Max | Unit |
|--------|-----------|-----------------|-----|-----|-----|------|
|--------|-----------|-----------------|-----|-----|-----|------|

## VCC SUPPLY

|                      |                       |                         |     |     |     |               |
|----------------------|-----------------------|-------------------------|-----|-----|-----|---------------|
| VCC                  | Supply voltage range  |                         | 4.6 | –   | 5.4 | V             |
| ICC                  | VCC Quiescent current | Enable low, 2nd time    | –   | –   | 100 | $\mu\text{A}$ |
|                      |                       | 8 phase operation       | –   | 40  | –   | mA            |
|                      |                       | 1 phase – DCM operation | –   | 10  | –   | mA            |
| UVLO <sub>Rise</sub> | UVLO Threshold        | VCC Rising              | –   | –   | 4.5 | V             |
| UVLO <sub>Fall</sub> |                       | VCC Falling             | 4   | –   | –   | V             |
| UVLO <sub>Hyst</sub> | VCC UVLO Hysteresis   |                         | –   | 200 | –   | mV            |

## SWITCHING FREQUENCY

|                        |                              |                           |     |   |      |     |
|------------------------|------------------------------|---------------------------|-----|---|------|-----|
| F <sub>SW</sub>        | Switching Frequency Range    | 8 phase configuration     | 250 | – | 1200 | kHz |
| $\Delta F_{\text{SW}}$ | Switching Frequency Accuracy | F <sub>SW</sub> = 810 kHz | –4  | – | +4   | %   |

## ENABLE INPUT

|                 |                 |                 |      |   |     |               |
|-----------------|-----------------|-----------------|------|---|-----|---------------|
| I <sub>L</sub>  | Input Leakage   | EN = 0 V or VCC | –1.0 | – | 1.0 | $\mu\text{A}$ |
| V <sub>IH</sub> | Upper Threshold |                 | 1.2  | – | –   | V             |
| V <sub>IL</sub> | Lower Threshold |                 | –    | – | 0.6 | V             |

## DRON

|                                 |  |  |     |     |     |            |
|---------------------------------|--|--|-----|-----|-----|------------|
| V <sub>OH</sub>                 | Output High Voltage                    | Sourcing 500 $\mu\text{A}$                   | 3.0 | –   | –   | V          |
| V <sub>OL</sub>                 | Output Low Voltage                     | Sinking 500 $\mu\text{A}$                    | –   | –   | 0.1 | V          |
| t <sub>R</sub> , t <sub>F</sub> | Rise time (Note 3)                     | CI (PCB) = 20 pF, $\Delta V_o = 10\%$ to 90% | –   | 160 | –   | ns         |
|                                 | Fall time (Note 3)                     | CI (PCB) = 20 pF, $\Delta V_o = 10\%$ to 90% | –   | 3   | –   | ns         |
| R <sub>PULL-UP</sub>            | Internal Pull-up Resistance (Note 3)   |  | –   | 2.0 | –   | k $\Omega$ |
| R <sub>PULL-DOWN</sub>          | Internal Pull Down Resistance (Note 3) | V <sub>cc</sub> = 0 V                        | –   | 12  | –   | k $\Omega$ |

## PGOOD

|                    |                                    |  |   |   |     |               |
|--------------------|------------------------------------|--|---|---|-----|---------------|
| V <sub>OL</sub>    | Output low voltage                 | I <sub>PGOOD</sub> = 10 mA (sink)  | – | – | 0.4 | V             |
| I <sub>L</sub>     | Leakage Current                    | P <sub>GOOD</sub> = 5 V  | – | – | 0.2 | $\mu\text{A}$ |
| T <sub>init</sub>  | Output voltage initialization time | From EN to ramp starts, 2nd ENABLE   | – | – | 0.5 | ms            |
| T <sub>total</sub> | Total Soft Startup Period          | T <sub>Ramp</sub> ≤ 0101, RT <sub>Ramp</sub> ≤ 41.2 k $\Omega$ ;<br>From EN to PGOOD | – | – | 2.0 | ms            |

## VRMP

|                        |                      |              |     |     |     |    |
|------------------------|----------------------|--------------|-----|-----|-----|----|
| VRMP                   | Supply Range         |              | 2.8 | –   | 20  | V  |
| V <sub>RMP</sub> rise  | UVLO                 | VRMP rising  | –   | –   | 2.8 | V  |
| V <sub>RMP</sub> fall  |                      | VRMP falling | 2.5 | –   | –   | V  |
| V <sub>RMP</sub> physt | VRMP UVLO Hysteresis |              | –   | 150 | –   | mV |

## PROTECTION FEATURES: OVP, UVP, TMON, ILIM, CLIM, TSD

|                    |   |                           |     |     |      |               |
|--------------------|---|---------------------------|-----|-----|------|---------------|
| UVP                | Under Voltage Protection (UVP) Threshold            | Relative to REFIN Voltage | –   | –   | –400 | mV            |
| T <sub>UVP</sub>   | Under Voltage Protection (UVP) Delay (Note 3)       |                           | –   | 5   | –    | $\mu\text{s}$ |
| OVP                | Over Voltage Protection (OVP) Threshold             | Relative to REFIN Voltage | 500 | –   | –    | mV            |
| T <sub>OVP</sub>   | Over Voltage Protection (OVP) Delay (Note 3)        |                           | –   | 5   | –    | $\mu\text{s}$ |
| T <sub>MON</sub>   | External Temperature Monitoring (TMON) Linear Range |                           | 0.6 | –   | 1.9  | V             |
| T <sub>MONLT</sub> | TMON Latch Threshold                                | Default                   | 1.9 | 2.0 | 2.1  | V             |

# NCP81610

**ELECTRICAL CHARACTERISTICS** ( $-10^{\circ}\text{C} < T_A < 100^{\circ}\text{C}$ ;  $4.6\text{ V} < V_{CC} < 5.4\text{ V}$ ;  $C_{VCC} = 0.1\ \mu\text{F}$  unless otherwise noted) (continued)

| Symbol | Parameter | Test Conditions | Min | Typ | Max | Unit |
|--------|-----------|-----------------|-----|-----|-----|------|
|--------|-----------|-----------------|-----|-----|-----|------|

## PROTECTION FEATURES: OVP, UVP, TMON, ILIM, CLIM, TSD

|                |  |                    |     |     |     |                  |
|----------------|--|--------------------|-----|-----|-----|------------------|
| $T_{MONLN}$    | TMON Linear Range                          |                    | 0   | -   | 2.0 | V                |
| $T_{MON\_ADC}$ | TMON Input to ADC Accuracy                 |                    | -   | 5   | -   | %                |
| $T_{SD}$       | Chip Thermal Shutdown Temperature (Note 3) | Temperature Rising | 145 | 155 | -   | C                |
| $T_{SD\_HYS}$  | Chip Thermal Shutdown Hysteresis (Note 3)  |                    | -   | 15  | -   | C                |
| $CLIM_{FALL}$  | CLIM Overall Current Limit Entering        | CSCOMP Falling     | -   | 225 | -   | mV               |
| $I_{LIM}$      | ILIM Sourcing Current                      |                    | 9   | 10  | 11  | $\mu\text{A}$    |
| $V_{LIM}$      | ILIM range                                 |                    | 0   | -   | 2   | V                |
| $R_{LIM}$      | RILIM range                                |                    | 0   | -   | 200 | $\text{k}\Omega$ |

## PWM OUTPUTS

|                 |                             |   |              |          |     |               |
|-----------------|-----------------------------|---|--------------|----------|-----|---------------|
| $V_{OH}$        | Output High Voltage         | Sourcing $500\ \mu\text{A}$   | $V_{CC}-0.2$ | -        | -   | V             |
| $V_{MID}$       | Output Mid Voltage          |   | 1.4          | 1.5      | 1.6 | V             |
| $V_{OL}$        | Output Low Voltage          | Sinking $500\ \mu\text{A}$  | -            | -        | 0.6 | V             |
| $t_R, t_F$      | Rise and Fall Time (Note 3) | $C_L(\text{PCB}) = 50\ \text{pF}$ , $\Delta V_o = 10\%$ to $90\%$ of $V_{CC}$ | -            | 10       | -   | ns            |
| $I_L$           | Tri-State Output Leakage    | $G_x = 2.0\ \text{V}$ , $x = 1 - 8$ , $EN = \text{Low}$                       | -1.0         | -        | 1.0 | $\mu\text{A}$ |
| $T_{on}$        | Minimum On Time (Note 3)    | $FSW=600\ \text{kHz}$   | -            | 12       | -   | ns            |
| $V_{COMP0\%}$   | 0% Duty Cycle               | Comp voltage when PWM = Low   | -            | 1.3      | -   | V             |
| $V_{COMP100\%}$ | 100% Duty Cycle             | Comp voltage when PWM = High  | -            | 2.5      | -   | V             |
| $\emptyset$     | PWM Phase Angle Error       | Between Adjacent phases   | -            | $\pm 15$ | -   | $^{\circ}$    |

## PHASE DETECTION

|             |                                   |              |   |     |              |    |
|-------------|-----------------------------------|--------------|---|-----|--------------|----|
| $V_{PHDET}$ | Phase Detection Threshold Voltage | CSP2 to CSP8 | - | -   | $V_{CC}-0.1$ | V  |
| $T_{PHDET}$ | Phase Detect Timer (Note 3)       | CSP2 to CSP8 | - | 1.1 | -            | ms |

## ERROR AMPLIFIER

|            |   |   |      |    |     |                        |
|------------|---|---|------|----|-----|------------------------|
| $I_{BIAS}$ | Input Bias Current                      |   | -400 | -  | 400 | nA                     |
| $G_{OL}$   | Open Loop DC Gain (Note 3)              | $C_L = 20\ \text{pF}$ to GND, $R_L = 10\ \text{k}\Omega$ to GND   | -    | 80 | -   | dB                     |
| GBW        | Open Loop Unity Gain Bandwidth (Note 3) | $C_L = 20\ \text{pF}$ to GND, $R_L = 10\ \text{k}\Omega$ to GND   | -    | 20 | -   | MHz                    |
| SR         | Slew Rate (Note 3)                      | $\Delta V_{in} = 100\ \text{mV}$ , $G = -10\ \text{V/V}$ ,<br>$\Delta V_{out} = 0.75\ \text{V} - 1.52\ \text{V}$ ,<br>$C_L = 20\ \text{pF}$ to GND, $R_L = 10\ \text{k}\Omega$ to GND | -    | 5  | -   | $\text{V}/\mu\text{s}$ |
| $V_{OUT}$  | Maximum Output Voltage                  | $I_{SOURCE} = 2\ \text{mA}$   | 3.5  | -  | -   | V                      |
| $V_{OUT}$  | Minimum Output Voltage                  | $I_{SINK} = 2\ \text{mA}$   | -    | -  | 1   | V                      |

## DIFFERENTIAL SUMMING AMPLIFIER

|            |                                       |   |      |    |     |     |
|------------|---------------------------------------|---|------|----|-----|-----|
| $I_{BIAS}$ | Input bias current                    |   | -400 | -  | 400 | nA  |
| $V_{IN}$   | VSP input voltage                     |   | 0    | -  | 2   | V   |
| $V_{IN}$   | VSN input voltage                     |   | -0.3 | -  | 0.3 | V   |
| BW         | -3 dB Bandwidth (Note 3)              | $C_L = 20\ \text{pF}$ to GND, $R_L = 10\ \text{k}\Omega$ to GND | -    | 12 | -   | MHz |
| G          | Closed loop DC gain (VSP-VSN to DIFF) | VSP to VSN = 0.5 to 1.3 V                                       | -    | 1  | -   | V/V |
| $V_{OUT}$  | Maximum output voltage                | $I_{SOURCE} = 2\ \text{mA}$                                     | 3    | -  | -   | V   |
| $V_{OUT}$  | Minimum output voltage                | $I_{SINK} = 2\ \text{mA}$                                       | -    | -  | 0.8 | V   |

# NCP81610

**ELECTRICAL CHARACTERISTICS** ( $-10^{\circ}\text{C} < T_A < 100^{\circ}\text{C}$ ;  $4.6\text{ V} < V_{CC} < 5.4\text{ V}$ ;  $C_{VCC} = 0.1\ \mu\text{F}$  unless otherwise noted) (continued)

| Symbol | Parameter | Test Conditions | Min | Typ | Max | Unit |
|--------|-----------|-----------------|-----|-----|-----|------|
|--------|-----------|-----------------|-----|-----|-----|------|

## CURRENT SUMMING AMPLIFIER

|           |   |   |      |    |     |               |
|-----------|---|---|------|----|-----|---------------|
| $V_{OS}$  | Offset Voltage                              |   | -500 | -  | 500 | $\mu\text{V}$ |
| $I_L$     | Input Bias Current                          | $CSSUM = CSREF = 1\text{ V}$                                    | -7.5 | -  | 7.5 | $\mu\text{A}$ |
| G         | Open Loop Gain (Note 3)                     |   | -    | 80 | -   | dB            |
| GBW       | Current sense Unity Gain Bandwidth (Note 3) | $C_L = 20\ \text{pF}$ to GND, $R_L = 10\ \text{k}\Omega$ to GND | -    | 10 | -   | MHz           |
| $V_{OUT}$ | Maximum CSCOMP Output Voltage               | $I_{SOURCE} = 2\ \text{mA}$                                     | 3.5  | -  | -   | V             |
| $V_{OUT}$ | Minimum CSCOMP Output Voltage               | $I_{SINK} = 1\ \text{mA}$                                       | -    | -  | 0.3 | V             |

## PHASE CURRENT AMPLIFIER

|                 |  |   |      |     |     |     |
|-----------------|--|---|------|-----|-----|-----|
| $I_{BIAS}$      | Input Bias Current                                   | $CSPX - CSPX + 1 = 1.2\text{ V}$                  | -50  | -   | 50  | nA  |
| $V_{CM}$        | Common Mode Input Voltage Range (Note 3)             | $CSPx = CSREF$                                    | 0    | -   | 2   | V   |
| $V_{DIFF}$      | Differential Mode Input Voltage Range                | $CSREF = 1.2\text{ V}$                            | -250 | -   | 250 | mV  |
|                 | Closed loop Input Offset Voltage Matching            | $CSPx = 2\text{ V}$ , Measured from the average   | -1.5 | -   | 1.5 | mV  |
| G               | Current Sense Amplifier Gain                         | $-250\ \text{mV} < CSPx - CSREF < 250\ \text{mV}$ | 5.5  | 6.0 | 6.5 | V/V |
| BW              | -3dB Bandwidth (Note 3)                              |   | -    | 8   | -   | MHz |
| $V_{ZCD}$       | Single Phase ZCD comparator threshold $CSP1 - CSREF$ | $PSI = 0$ , Single Phase, By Default              | -    | 0   | -   | mV  |
| $T_{ZCD}$       | ZCD Comparator Delay (Note 3)                        |   | -    | 150 | -   | ns  |
| $V_{ZCD\_UNIT}$ | ZCD User Trim Resolution (Note 3)                    |   | -    | 1.2 | -   | mV  |

## IOUT

|                 |                                |                             |     |     |    |               |
|-----------------|--------------------------------|-----------------------------|-----|-----|----|---------------|
| $V_{OS}$        | Input Reference Offset Voltage | CSCOMP to CSREF             | -10 | -   | 10 | mV            |
| $I_{OUT}$       | Output Current Max             | 10 $\mu\text{A}$ on Rcur    | -   | 100 | -  | $\mu\text{A}$ |
| $G_{IOUT}$      | IOUT Current Gain              | $I_{out} / I_{Rcur}$        | -   | 10  | -  | A/A           |
| $V_{IOUT\_RG}$  | IOUT Linear Range              |                             | 0   | -   | 3  | V             |
| $V_{IOUT\_ADC}$ | IOUT Input to ADC Accuracy     | $0 < V_{IOUT} < 2\text{ V}$ | -   | 5   | -  | %             |

## VOLTAGE REFERENCE

|                  |                         |                          |      |   |      |   |
|------------------|-------------------------|--------------------------|------|---|------|---|
| VREF             | VREF Reference Voltage  | $I_{REF} = 1\ \text{mA}$ | 1.98 | 2 | 2.02 | V |
| $\Delta V_{REF}$ | VREF Reference accuracy | Over Temp                | -    | 1 | 1.5  | % |

## PWM\_VID BUFFER

|                 |  |                                       |     |     |      |     |
|-----------------|--|---------------------------------------|-----|-----|------|-----|
| $V_{IH}$        | Upper threshold                        |                                       | 1.4 | -   | -    | V   |
| $V_{IL}$        | Lower threshold                        |                                       | -   | -   | 0.5  | V   |
| $F_{PWM\_VID}$  | PWM_VID switching frequency            |                                       | 400 | -   | 5000 | kHz |
| $t_R$           | Output Rise Time (Note 3)              |                                       | -   | 3   | -    | ns  |
| $t_F$           | Output Fall Time (Note 3)              |                                       | -   | 3   | -    | ns  |
| $\Delta t$      | Rising and falling edge delay (Note 3) | $\Delta t = t_R - t_F$                | -   | 0.5 | -    | ns  |
| $t_{PD}$        | Propagation Delay (Note 3)             | $t_{PD} = t_{PDHL} = t_{PDLH}$        | -   | 8   | -    | ns  |
| $\Delta t_{PD}$ | Propagation Delay Error (Note 3)       | $\Delta t_{PD} = t_{PDHL} - t_{PDLH}$ | -   | 0.5 | -    | ns  |

## VOCL\_min

|              |                        |                          |     |   |     |   |
|--------------|------------------------|--------------------------|-----|---|-----|---|
| VOCL_min     | VOCL_min voltage range |                          | 0.2 | - | 1.3 | V |
| VOCL_min_var | VOCL_min accuracy      | $VOCL\_min = 1\text{ V}$ | -   | 2 | -   | % |

## PSI

|          |                    |  |      |   |   |   |
|----------|--------------------|--|------|---|---|---|
| $V_{IH}$ | PSI high Threshold |  | 1.45 | - | - | V |
|----------|--------------------|--|------|---|---|---|

# NCP81610

**ELECTRICAL CHARACTERISTICS** ( $-10^{\circ}\text{C} < T_A < 100^{\circ}\text{C}$ ;  $4.6\text{ V} < V_{CC} < 5.4\text{ V}$ ;  $C_{VCC} = 0.1\ \mu\text{F}$  unless otherwise noted) (continued)

| Symbol     | Parameter                 | Test Conditions                  | Min | Typ | Max   | Unit          |
|------------|---------------------------|----------------------------------|-----|-----|-------|---------------|
| <b>PSI</b> |                           |                                  |     |     |       |               |
| $V_{MID}$  | PSI mid threshold         | Auto Phase Shedding Enabled      | 0.8 | -   | 1     | V             |
| $V_{IL}$   | PSI low threshold         |                                  | -   | -   | 0.575 | V             |
| $I_L$      | PSI input leakage current | $V_{PSI} = 0\text{ V o } V_{CC}$ | -1  | -   | 1     | $\mu\text{A}$ |

|                |                            |  |   |   |     |   |
|----------------|----------------------------|--|---|---|-----|---|
| <b>VMON</b>    |                            |  |   |   |     |   |
| $V_{MONLN}$    | VMON Linear Range          |  | 0 | - | 2.0 | V |
| $V_{MON\_ADC}$ | VMON Input to ADC Accuracy |  | - | 5 | -   | % |

|                     |   |  |   |    |   |          |
|---------------------|---|--|---|----|---|----------|
| <b>REFIN</b>        |   |  |   |    |   |          |
| $R_{DISCH}$         | REFIN Discharge Switch ON- Resistance (Note 3)  | $I_{REEFIN}(\text{SINK}) = 2\text{ mA}$                      | - | 10 | - | $\Omega$ |
| $V_{ORP}/V_{REFIN}$ | Ratio of Output voltage ripple transferred from REFIN / REFIN Voltage ripple (Note 3) | $F_{PWM\_VID} = 400\text{ kHz}, F_{SW} \leq 600\text{ kHz}$  | - | 10 | - | %        |
| $V_{ORP}/V_{REFIN}$ |   | $F_{PWM\_VID} = 1000\text{ kHz}, F_{SW} \leq 600\text{ kHz}$ | - | 30 | - |          |

|                                |                                      |                          |     |    |     |               |
|--------------------------------|--------------------------------------|--------------------------|-----|----|-----|---------------|
| <b>I<sup>2</sup>C (Note 3)</b> |                                      |                          |     |    |     |               |
| $V_{IH}$                       | Logic High Input Voltage             |                          | 1.4 | -  | 5   | V             |
| $V_{IL}$                       | Logic Low Input Voltage              |                          | 0   | -  | 0.5 | V             |
|                                | Hysteresis                           |                          | -   | 80 | -   | mV            |
| $V_{OL}$                       | Output Low Voltage                   | $I_{SDA} = -6\text{ mA}$ | -   | -  | 0.4 | V             |
| $I_L$                          | Input Current                        |                          | -1  | -  | 1   | $\mu\text{A}$ |
| $C_{SDA}, C_{SCL}$             | Input Capacitance                    |                          | -   | 5  | -   | pF            |
| $f_{SCL}$                      | Clock Frequency                      | see Figure 2             | -   | -  | 400 | kHz           |
| $t_{LOW}$                      | SCL Low period                       |                          | 1.3 | -  | -   | $\mu\text{s}$ |
| $t_{HIGH}$                     | SCL High period                      |                          | 0.6 | -  | -   | $\mu\text{s}$ |
| $t_R$                          | SCL/SDA rise time                    |                          | -   | -  | 300 | ns            |
| $t_F$                          | SCL/SDA fall time                    |                          | -   | -  | 300 | ns            |
| $t_{SU;STA}$                   | Start condition setup time           |                          | 600 | -  | -   | ns            |
| $t_{HD;STA}$                   | Start condition hold time (Note 4)   |                          | 600 | -  | -   | ns            |
| $t_{SU;DAT}$                   | Data setup time (Note 5)             |                          | 100 | -  | -   | ns            |
| $t_{HD;DAT}$                   | Data hold time (Note 5)              |                          | 300 | -  | -   | ns            |
| $t_{SU;STO}$                   | Stop condition setup time (Note 6)   |                          | 600 | -  | -   | ns            |
| $t_{BUF}$                      | Bus free time between stop and start |                          | 1.3 | -  | -   | $\mu\text{s}$ |

3. Guaranteed by design, not production tested.
4. Time from 10% of SDA to 90% of SCL
5. Time from 10% or 90% of SDA to 10% of SCL
6. Time from 90% of SCL to 10% of SDA

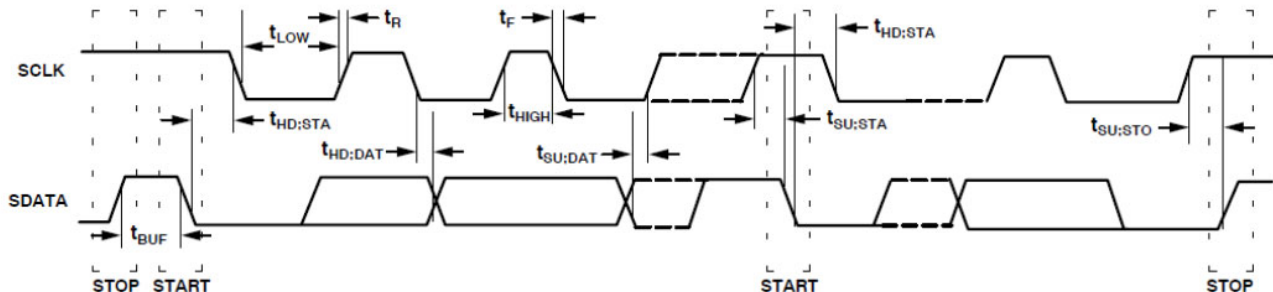

Figure 2. I<sup>2</sup>C Timing Diagram



# NCP81610

## Applications Information

The NCP81610 is a multi-phase buck converter controller optimized for the next generation computing and graphic processor applications. It contains eight PWM channels which can be individually configured to operate from one to eight phases.

The output voltage is set by applying a PWM signal to the PWM\_VID input of the device. The controller converts the PWM\_VID signal (400 kHz ~ 5 MHz) with variable high and low levels into a 2 V PWM signal which is then being filtered and averaged, and applied to the REFIN pin for internal regulation reference.

The remote output voltage and ground are differentially sensed and the REFIN value is subtracted from sensed voltage. The result is biased, combined with loadline input and applied to the error amplifier. If the loadline is disabled, any difference between the sensed output voltage and the

REFIN pin average voltage will change the PWM outputs duty cycle until the two voltages are identical. The load current is continuously monitored on each phase and the PWM outputs are adjusted to ensure even distribution of the load current across all phases. Per phase current is monitored cycle by cycle with current limiting.

The device incorporates different fault protections including per phase overcurrent limiting (OCL), on chip over temperature (TSD), external power stage over temperature monitoring (TMON), output under voltage (UVP) and output overvoltage (OVP) protections.

The communication between the NCP81610 and the user is handled with two interfaces, PWM\_VID to set the output voltage and I<sup>2</sup>C to configure or monitor the status of the controller. The operation of the internal blocks of the device is described in more details in the following sections.

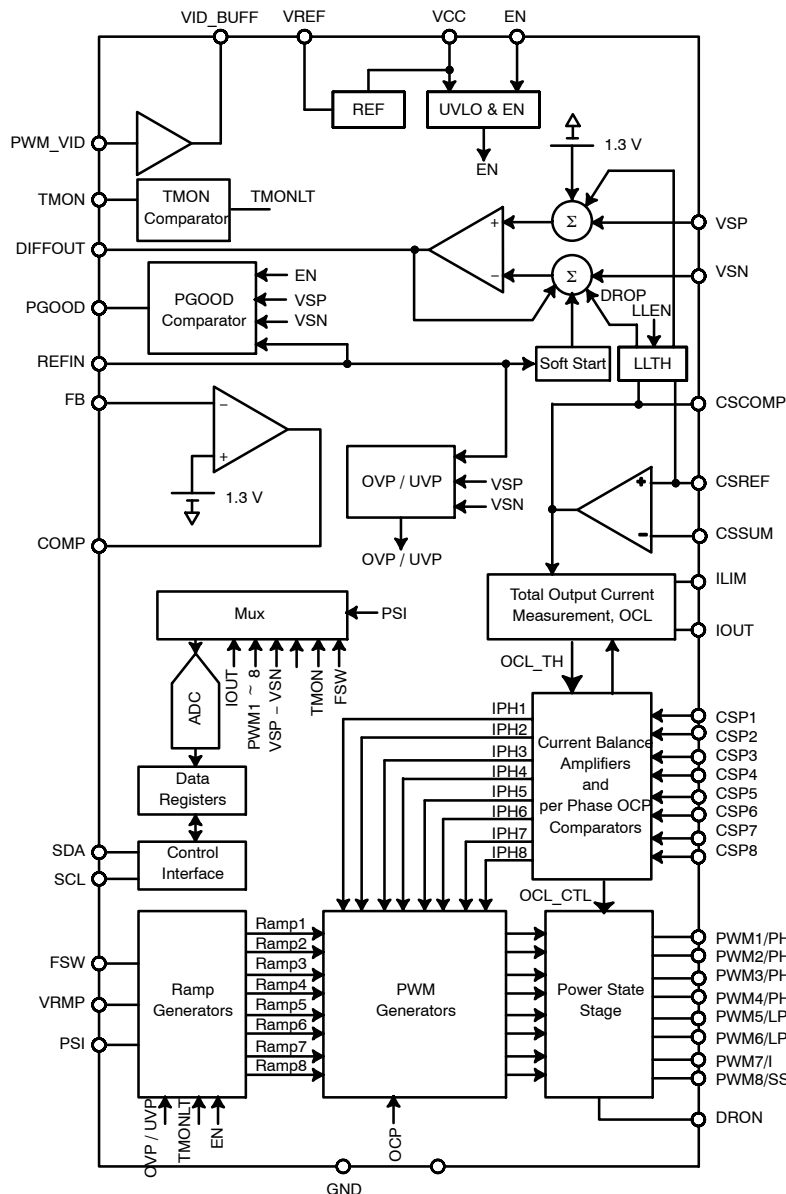

Figure 3. NCP81610 Functional Block Diagram

*Soft Start*

Soft start is defined as the transition from Enable assertion high to the assertion of Power good as shown in Figures 4, 5.

The output is set to the desired voltage in two steps:  $T_{init}$  is a fixed initialization step of less than 1 ms followed by a ramp-up step  $T_{ramp}$  where the output voltage is ramped to the final value set by the PWM\_VID interface and REFIN. During the soft start phase, PGOOD pin is initially set low and will be set high when the output voltage is within regulation and the soft start is complete. The PGOOD signal

only de-asserts (pull low) when the controller shuts down due to a fault condition (UVLO, OVP or UVP event).

The output voltage ramp-up time is user settable by connecting a resistor between pin PWM8/SS and GND. The controller will measure the resistance value at power-up by sourcing a 10  $\mu$ A current through this resistor and set the ramp time ( $T_{ramp}$ ) as shown in Table 11. To prevent false over current claim, CSREF signal of the current summing amplifier needs to be ready before the soft start is complete.

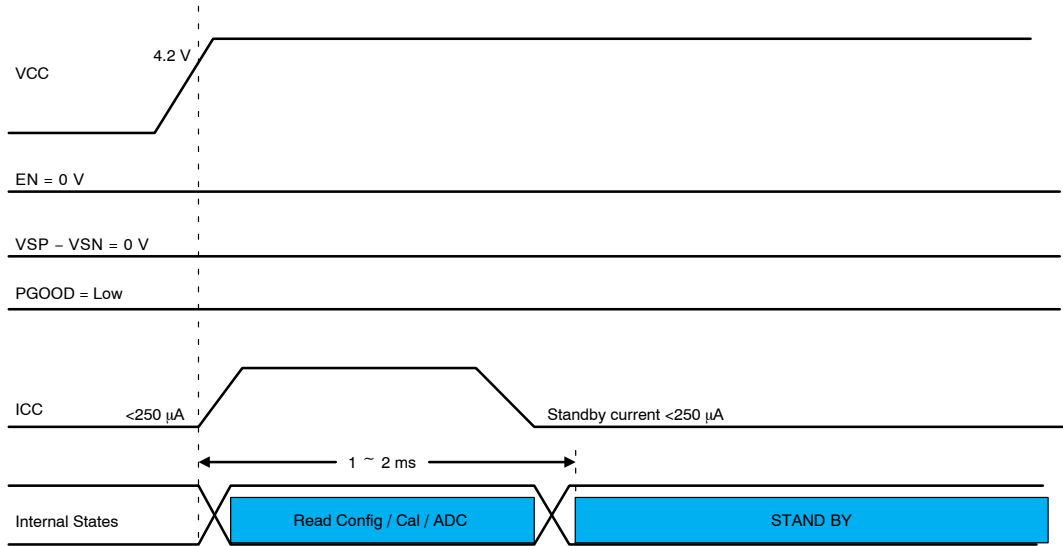

Figure 4. VCC across UVLO with EN = 0

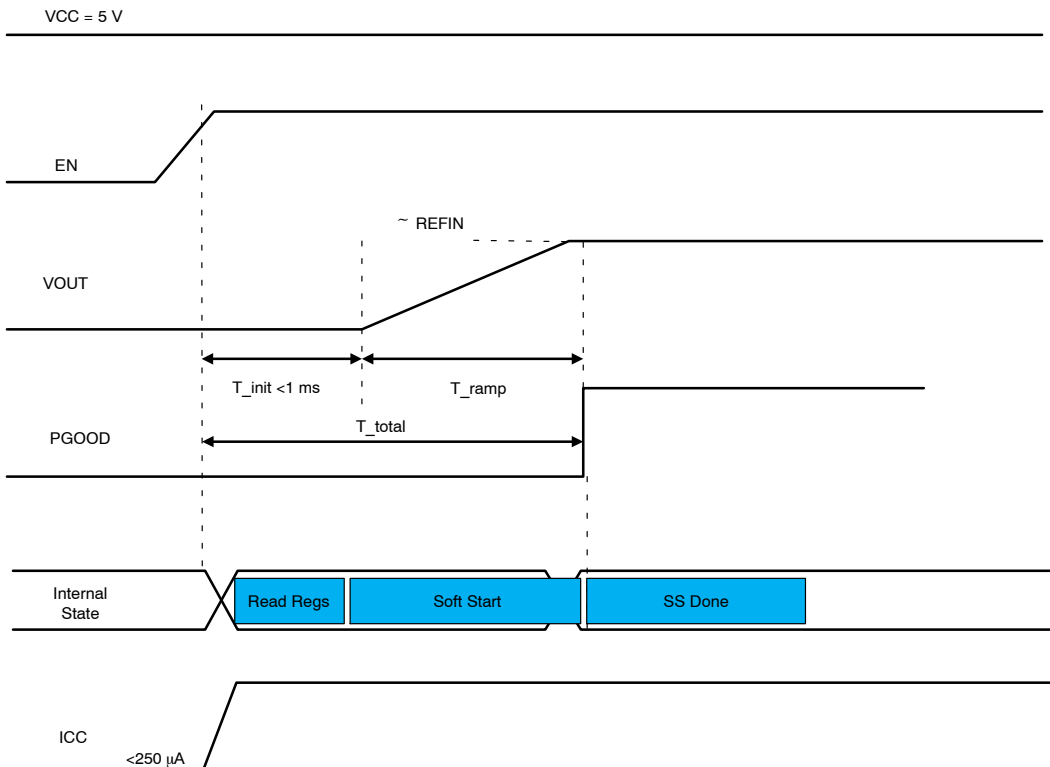

Figure 5. Soft Start by Toggling EN

*PWM\_VID Interface*

PWM-VID is a single wire dynamic voltage control interface where the regulated voltage is set by the duty cycle of the PWM signal applied to the controller.

The device controller converts the variable amplitude PWM signal into a constant 2 V amplitude PWM signal while preserving the duty cycle information of the input signal. In addition, if the PWM\_VID input is left floating, the VID\_BUFF output is tri-stated (floating).

The constant amplitude PWM signal is then connected to the REFIN pin through a scaling and filtering network (see Figure 6). This network allows the user to set the minimum and maximum REFIN voltages corresponding to 0% and 100% duty cycle values.

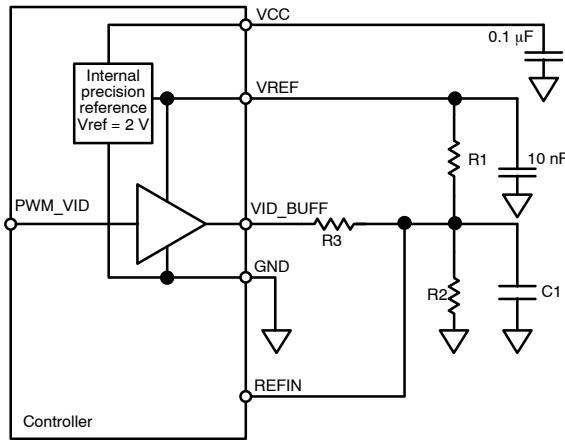

**Figure 6. PWM VID Interface**

The minimum (0% duty cycle), maximum (100% duty cycle) and boot (PWM\_VID input floating) voltages can be calculated with the following formula:

$$V_{MAX} = V_{REF} \cdot \frac{1}{1 + \frac{R_1 \cdot R_3}{R_2 \cdot (R_1 + R_3)}} \quad (\text{eq. 1})$$

$$V_{MIN} = V_{REF} \cdot \frac{1}{1 + \frac{R_1 \cdot (R_2 + R_3)}{R_2 \cdot R_3}} \quad (\text{eq. 2})$$

$$V_{BOOT} = V_{REF} \cdot \frac{1}{1 + \frac{R_1}{R_2}} \quad (\text{eq. 3})$$

*Remote Voltage Sense*

A high performance true differential amplifier allows the controller to measure the output voltage directly at the load using the VSP (VOUT) and VSN (GND) pins. This keeps the ground potential differences between the local controller ground and the load ground reference point from affecting regulation of the load. The output voltage of the differential amplifier is set by the following equation:

$$V_{DIFOUT} = (V_{VSP} - V_{VSN}) + (1.3 \text{ V} - V_{REFIN}) + (V_{DROOP} - V_{CSREF}) \quad (\text{eq. 4})$$

where,

$V_{DIFOUT}$  is the output voltage of the differential amplifier

$V_{VSP} - V_{VSN}$  is the regulated output voltage sensed at the load

$V_{REFIN}$  is the voltage at the output pin set by the PWM\_VID interface

$V_{DROOP} - V_{CSREF}$  is the expected drop in the regulated voltage as a function of the load current (load-line)

1.3 V is an internal reference voltage used to bias the amplifier inputs to allow both positive and negative output voltage for  $V_{DIFOUT}$

*Error Amplifier*

A high performance wide bandwidth error amplifier is provided for fast response to transient load events. Its inverting input is biased internally with the same 1.3 V reference voltage as the one used by the differential sense amplifier to ensure that both positive and negative error voltages are correctly handled.

An external compensation circuit should be used (usually type III) to ensure that the control loop is stable and has adequate response.

*Ramp Feed-Forward Circuit*

The ramp generator circuit provides the ramp used to generate the PWM signals using internal comparators (see Figure 7) The ramp generator provides voltage feed-forward control by varying the ramp magnitude with respect to the VRMP pin voltage.

The VRMP pin also has a UVLO function. The VRMP UVLO rising threshold is 2.8 V, only active after the EN is toggled high. The VRMP pin is a high impedance input when the controller is disabled.

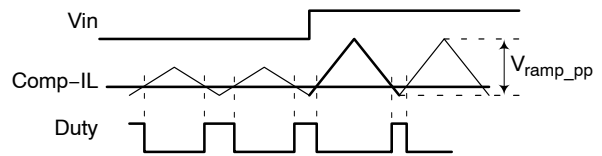

**Figure 7. Ramp Feed-Forward Circuit**

*PWM Output Configuration*

By default the controller operates in 8 phase mode, however the phases can be disabled by connecting the corresponding CSP pins to VCC. At power-up the NCP81610 measures the voltage present at each CSP pin and compares it with the phase detection threshold. If the voltage exceeds the threshold, the phase is disabled. The phase configurations that can be achieved by the device are listed in Table 2. The active phase (PWM<sub>X</sub>) information is also available to the user in the phase status register.

# NCP81610

## PSI, LPC<sub>X</sub>, PHTH<sub>X</sub>

The NCP81610 incorporates a power saving interface (PSI) to maximize the efficiency of the regulator under various loading conditions. The device supports up to five distinct operation modes, called power zones using the PSI, LPC<sub>X</sub> and PHTH<sub>X</sub> pins (see Table 3). At power-up the controller reads the PSI pin logic state and sources a 10 μA current through the resistors connected to the LPC<sub>X</sub> and PHTH<sub>X</sub> pins, measures the voltage at these pins and configures the device accordingly.

The configuration can be changed by the user by writing to the LPC<sub>X</sub> and PHTH<sub>X</sub> configuration registers.

After EN is set high, the NCP81610 ignores any change in the PSI pin logic state until the output voltage reaches the nominal regulated voltage.

When PSI = High, the controller operates with all active phases enabled regardless of the load current. If PSI = Mid, the NCP81610 operates in dynamic phase shedding mode where the voltage present at the IOUT pin (the total load current) is measured every 10 μs and compared to the PHTH<sub>X</sub> thresholds to determine the appropriate power zone.

The resistors connected between the PHTH<sub>X</sub> and GND should be picked to ensure that with a 10 μA source current the voltage reading will match the voltage drop at the IOUT pin at the desired load current. Please note that the maximum allowable voltage at the IOUT pin at the maximum load current is 2 V. Any PHTH<sub>X</sub> threshold can be disabled if the voltage drop across the PHTH<sub>X</sub> resistor is ≥2 V for a 10 μA current, the pin is left floating or 0xFF is written to the appropriate PHTH<sub>X</sub> configuration register. The automatic phase shedding mode is only enabled after the output voltage reaches the nominal regulated voltage.

When PSI = low, the controller is set to a fixed power zone regardless of the load current, programmable through user register 0x34 and 0x36. The LPC2 setting controls the power zone used during cold boot-up (After power on VCC

UVLO, EN is set high) while the LPC1 configuration sets the power zone in the consecutive soft startup by toggling EN only (soft boot-up).

NCP81610 has the internal zero current detection function (ZCD) enabled by default; if PSI = Low and the system is configured to single phase mode (Power Zone = 4), the single phase switching circuit operates in diode emulation mode. The NCP81610 controller will sense the current information from CSP1–CSREF differential voltage in the internal ZCD mode with PWM1 toggling between High, Mid and Low voltage levels accordingly. The controller ZCD threshold can be adjusted by I<sup>2</sup>C command to accommodate different power stages and the propagation delay.

The ZCD function within the NCP81610 can be disabled through the I<sup>2</sup>C command. While internal ZCD function is disabled, PWM1 can be configured to either toggle between High and Low or High and Mid-level depending on type of the power stage devices; In this case the power stage current sensing circuit will be used for zero current detection function if necessary.

## NCP81610 I<sup>2</sup>C Address

On power up, a 10 μA current is sourced from PWM7/I2C pin to the shunt resistor to configure the I2C slave address of the NCP81610. There are four I2C addresses available for this chip associated with different shunt resistor values.

**Table 1. I2C ADDRESS SETTING**

| Resistance (kΩ) | I <sup>2</sup> C Address |
|-----------------|--------------------------|
| 10              | 0x20                     |
| 41.2            | 0x30                     |
| 100             | 0x40                     |
| 249             | 0x50                     |

**Table 2. PWM OUTPUT CONFIGURATION**

| Configuration | Phase Configuration | CSP Pin Configuration (✓ = Normal Connection, X = Tied to VCC) |      |      |      |      |      |      |      | Enabled PWM Outputs (PWM <sub>X</sub> Pins) |
|---------------|---------------------|--|------|------|------|------|------|------|------|---|
|               |                     | CSP1   | CSP2 | CSP3 | CSP4 | CSP5 | CSP6 | CSP7 | CSP8 |   |
| 1             | 8 phase             | ✓  | ✓    | ✓    | ✓    | ✓    | ✓    | ✓    | ✓    | 1, 2, 3, 4, 5, 6, 7, 8                      |
| 2             | 7 phase             | ✓  | ✓    | ✓    | ✓    | ✓    | ✓    | ✓    | X    | 1, 2, 3, 4, 5, 6, 7                         |
| 3             | 6 phase             | ✓  | ✓    | ✓    | ✓    | ✓    | ✓    | X    | X    | 1, 2, 3, 4, 5, 6                            |
| 4             | 5 phase             | ✓  | ✓    | ✓    | ✓    | ✓    | X    | X    | X    | 1, 2, 3, 4, 5                               |
| 5             | 4 phase             | ✓  | ✓    | ✓    | ✓    | X    | X    | X    | X    | 1, 2, 3, 4                                  |
| 6             | 3 phase             | ✓  | ✓    | ✓    | X    | X    | X    | X    | X    | 1, 2, 3                                     |
| 7             | 2 phase             | ✓  | ✓    | X    | X    | X    | X    | X    | X    | 1, 2  |
| 8             | 1 phase             | ✓  | X    | X    | X    | X    | X    | X    | X    | 1   |

# NCP81610

**Table 3. PSI, LPC<sub>x</sub>, PHTH<sub>x</sub> CONFIGURATION**

| PSI Logic State | LPC1, LPC2 Resistor (kΩ) | IOUT vs. PHTH <sub>x</sub> Comparison | Power Zone |         |         |         |         |         |         |         |
|-----------------|--------------------------|---------------------------------------|------------|---------|---------|---------|---------|---------|---------|---------|
|                 |                          |                                       | 8 Phase    | 7 Phase | 6 Phase | 5 Phase | 4 Phase | 3 Phase | 2 Phase | 1 Phase |
| High            | Disabled                 | Function Disabled                     | 0          | 0       | 0       | 0       | 0       | 0       | 0       | 0       |
| Low             | 10                       |                                       | 0          | 0       | 0       | 0       | 0       | 0       | 0       | 0       |
|                 | 23.2                     |                                       | 1          | 1       | 0       | 0       | 0       | 0       | 0       | 0       |
|                 | 37.4                     |                                       | 2          | 2       | 2       | 0       | 2       | 0       | 0       | 0       |
|                 | 54.9                     |                                       | 3          | 3       | 3       | 3       | 3       | 3       | 3       | 0       |
|                 | 78.7                     |                                       | 4          | 4       | 4       | 4       | 4       | 4       | 4       | 4       |
| Mid             | Function Disabled        | IOUT > PHTH4                          | 0          | 0       | 0       | 0       | 0       | 0       | 0       | 0       |
|                 |                          | PHTH4 > IOUT > PHTH3                  | 1          | 1       | 0       | 0       | 0       | 0       | 0       | 0       |
|                 |                          | PHTH3 > IOUT > PHTH2                  | 2          | 2       | 2       | 0       | 2       | 0       | 0       | 0       |
|                 |                          | PHTH2 > IOUT > PHTH1                  | 3          | 3       | 3       | 3       | 3       | 3       | 3       | 0       |
|                 |                          | IOUT < PHTH1                          | 4*         | 4       | 4       | 4       | 4       | 4       | 4       | 4       |

NOTES: Power zone 4 is usually DCM, while zones 0 to 3 are CCM.

**Table 4. PSI, LPC<sub>x</sub>, PHTH<sub>x</sub> CONFIGURATION**

| Power Zone | PWM Output Configuration | PWM Output Status (✓ = Enabled, X = Disabled) |      |      |      |      |      |      |      |
|------------|--------------------------|---|------|------|------|------|------|------|------|
|            |                          | PWM1  | PWM2 | PWM3 | PWM4 | PWM5 | PWM6 | PWM7 | PWM8 |
| 0          | 8 phase                  | ✓   | ✓    | ✓    | ✓    | ✓    | ✓    | ✓    | ✓    |
| 1          |                          | ✓   | X    | ✓    | X    | ✓    | X    | ✓    | X    |
| 2          |                          | ✓   | X    | X    | X    | ✓    | X    | X    | X    |
| 3          |                          | ✓   | X    | X    | X    | X    | X    | X    | X    |
| 4          |                          | ✓   | X    | X    | X    | X    | X    | X    | X    |
| 0          | 7 phase                  | ✓   | ✓    | ✓    | ✓    | ✓    | ✓    | ✓    | X    |
| 1          |                          | ✓   | X    | ✓    | ✓    | ✓    | X    | ✓    | X    |
| 2          |                          | ✓   | X    | X    | ✓    | X    | X    | ✓    | X    |
| 3          |                          | ✓   | X    | X    | X    | X    | X    | X    | X    |
| 4          |                          | ✓   | X    | X    | X    | X    | X    | X    | X    |
| 0          | 6 phase                  | ✓   | ✓    | ✓    | ✓    | ✓    | ✓    | X    | X    |
| 2          |                          | ✓   | X    | ✓    | X    | ✓    | X    | X    | X    |
| 3          |                          | ✓   | X    | X    | X    | X    | X    | X    | X    |
| 4          |                          | ✓   | X    | X    | X    | X    | X    | X    | X    |
| 0          | 5 phase                  | ✓   | ✓    | ✓    | ✓    | ✓    | X    | X    | X    |
| 3          |                          | ✓   | X    | X    | X    | X    | X    | X    | X    |
| 4          |                          | ✓   | X    | X    | X    | X    | X    | X    | X    |
| 0          | 4 phase                  | ✓   | ✓    | ✓    | ✓    | X    | X    | X    | X    |
| 2          |                          | ✓   | X    | ✓    | X    | X    | X    | X    | X    |
| 3          |                          | ✓   | X    | X    | X    | X    | X    | X    | X    |
| 4          |                          | ✓   | X    | X    | X    | X    | X    | X    | X    |

Table 4. PSI, LPC<sub>X</sub>, PHTH<sub>X</sub> CONFIGURATION

| Power Zone | PWM Output Configuration | PWM Output Status (✓ = Enabled, X = Disabled) |      |      |      |      |      |      |      |
|------------|--------------------------|---|------|------|------|------|------|------|------|
|            |                          | PWM1  | PWM2 | PWM3 | PWM4 | PWM5 | PWM6 | PWM7 | PWM8 |
| 0          | 3 phase                  | ✓   | ✓    | ✓    | X    | X    | X    | X    | X    |
| 3          |                          | ✓   | X    | X    | X    | X    | X    | X    | X    |
| 4          |                          | ✓   | X    | X    | X    | X    | X    | X    | X    |
| 0          | 2 phase                  | ✓   | ✓    | X    | X    | X    | X    | X    | X    |
| 3          |                          | ✓   | X    | X    | X    | X    | X    | X    | X    |
| 4          |                          | ✓   | X    | X    | X    | X    | X    | X    | X    |
| 0          | 1 phase                  | ✓   | X    | X    | X    | X    | X    | X    | X    |
| 4          |                          | ✓   | X    | X    | X    | X    | X    | X    | X    |

*Power Zone Transition / Phase Shedding*

The power zones supported by the NCP81610 are set by the resistors connected to the LPC<sub>X</sub> pins (PSI = Low) or PHTH<sub>X</sub> pins (PSI = Mid).

When PSI is set to the Mid-state, the NCP81610 employs a phase shedding scheme where the power zone is automatically adjusted for optimal efficiency by continuously measuring the total output current (voltage at the IOUT pin) and compare it with the PHTH<sub>X</sub> thresholds. When the comparison result indicates that a lower power zone number is required (an increase in the IOUT value), the controller jumps to the required power zone immediately.

A decrease in IOUT that indicates that the controller needs to switch into a higher power zone number, the transition will be executed with a delay of 200 μs set by the phase shed delay configuration register. The value of the delay can be adjusted by the user in steps of 10 μs if required.

To avoid excessive ripple on the output voltage, all power zone changes are gradual and include all intermediate power zones between the current zone and the target zone set by the comparison of the output current with the PHTH<sub>X</sub> thresholds, each transition introducing a programmable 200 μs delay.

To avoid false changes from one power zone to another caused by noise or short IOUT transients, the comparison between IOUT and PHTH<sub>X</sub> threshold uses hysteresis. The switch to a lower power zone is executed if IOUT exceeds the PHTH<sub>X</sub> threshold values while a transition to a higher power zone number is only executed if IOUT is below PHTH<sub>X</sub>-Hysteresis value. The hysteresis value is set to 0x44h and can be changed by the user by writing to the phase shedding configuration register. If a power zone/PHTH<sub>X</sub> threshold is disabled, the controller will skip it during the power zone transition process.

When PSI = Low and the user requires to change the power zone, the transition to the new power zone is identical to the transition process used when PSI is set to the Mid-state. The only exception is when the target power zone is disabled in automatic phase shedding mode. In this case, the controller will automatically enable the target power

zone and allow the transition. When the controller is set to automatic phase shedding, the power zone will be automatically disabled.

*VID Down Operation in Single Phase Mode*

When VID Down change bit (0x31) is enabled and there is a fast VID down transition (REFIN down) detected in single phase operation power zone (Zone 3 or Zone 4), the controller will force all phases to turn on for 2 ms to protect the external power stage against damage from large discharging current and achieve fast and smooth VID down transition in the meantime.

*Switching Frequency*

A programmable precision oscillator is provided for the switching frequency. The clock oscillator serves as the master clock to the ramp generator circuit. This oscillator is programmed by a resistor to ground on the FSW pin. The FSW pin provides approximately 2 V out and the source current is mirrored into the internal ramp oscillator. The oscillator frequency is approximately proportional to the current flowing in the resistor. Table 14 lists the switching frequencies that can be set using discrete resistor values for each phase configuration. Also, the switching frequency information is available in the FSW configuration register and it can be changed by the user by writing to the FSW configuration register.

*Total Current Summing: IMON Sensing Method*

The controller sums the phase currents from each current sense power stage device into a single total current signal (Figure 8). This signal is then used to generate the output voltage droop, total current limit, and the current monitoring output. The total current signal is the difference between CSCOMP and CSREF with CSREF connected to an external voltage bias as required by the power stage current sense output.

The DC gain equation for the current sensing is given by the following equation:

$$CSREF - CSCOMP = I_{out} \cdot A_{ips} \cdot R_{csum} \tag{eq. 5}$$

Where A<sub>ips</sub> is the current sense gain of the power stage.

# NCP81610

## Programming Load Line

The signals CSCOMP and CSREF are differentially summed with the output voltage feedback to add precision summed with the output voltage feedback to add precision voltage droop to the output voltage if the load line is enabled.

$$V_{\text{DROOP}} = \text{LLTH} \cdot (\text{CSREF} - \text{CSCOMP}) \quad (\text{eq. 6})$$

The load line Coefficient LLTH can be configured by I2C register 0x39 to 0% (default), 25%, 50%, 100%.

## Programming IOUT

The IOUT pin sources a current in proportion to the total output current summed up through the current summing amplifier. The voltage on the IOUT pin is monitored by the internal A/D converter and should be scaled with an external resistor to ground such that a load equal to system max current generates a 2 V signal on IOUT. A pull-up resistor to VCC can be used to offset the IOUT signal if needed.

$$I_{\text{out\_max}} \cdot A_{\text{ips}} \cdot R_{\text{cssum}} = \text{CSSUM} - \text{CSCOMP} = \text{CSREF} - \text{CSCOMP} \quad (\text{eq. 7})$$

As an example, if CSREF bias voltage is 1.3 V and the minimum summing amplifier output voltage is set to 0.3 V, the Aips x Rcssum has to be chosen to ensure Iout x Aips x Rcssum = CSREF - CSCOMP always less than 1 V in all the normal operating conditions. Since the internal resistor Rcur is 100 kΩ, that means a less than 10 μA pulling through Rcur in the normal operating conditions. For a 2 V maximum output voltage of IOUT pin, the shunt resistor Riout can be calculated by the following equation:

$$R_{\text{iout}} = \frac{2\text{V}}{10 \mu\text{A} \cdot 10} = 20 \text{ k}\Omega \quad (\text{eq. 8})$$

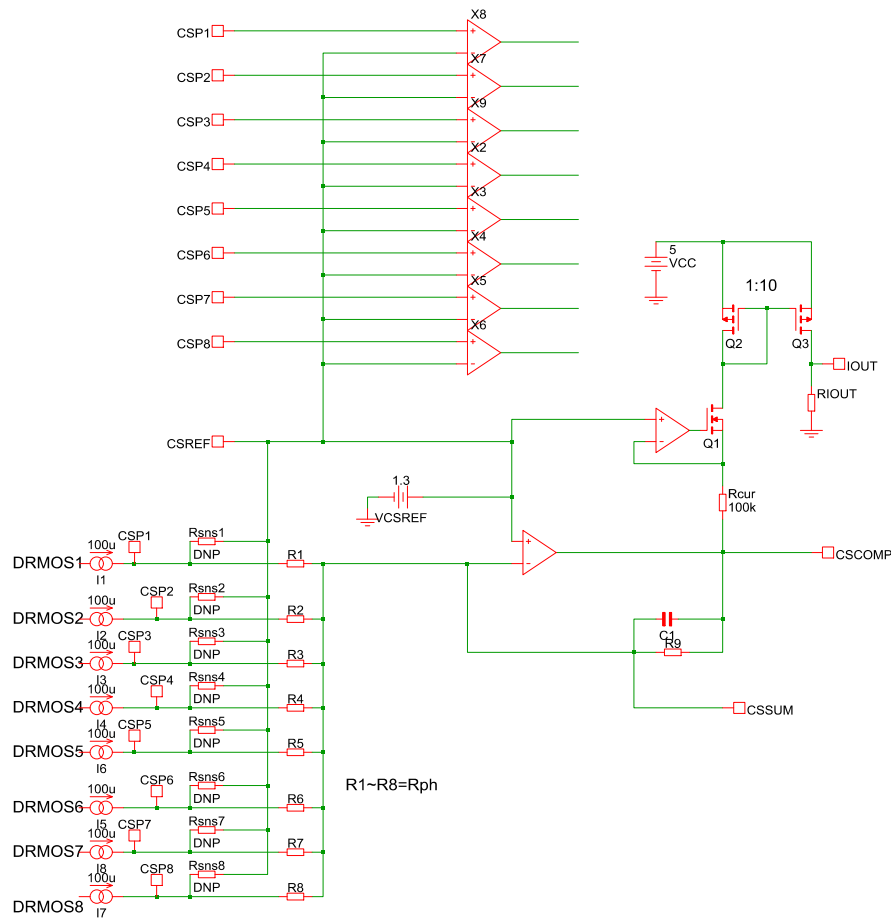

Figure 8. Total Current Summing Amplifier, DRMOS IMON Sensing

# NCP81610

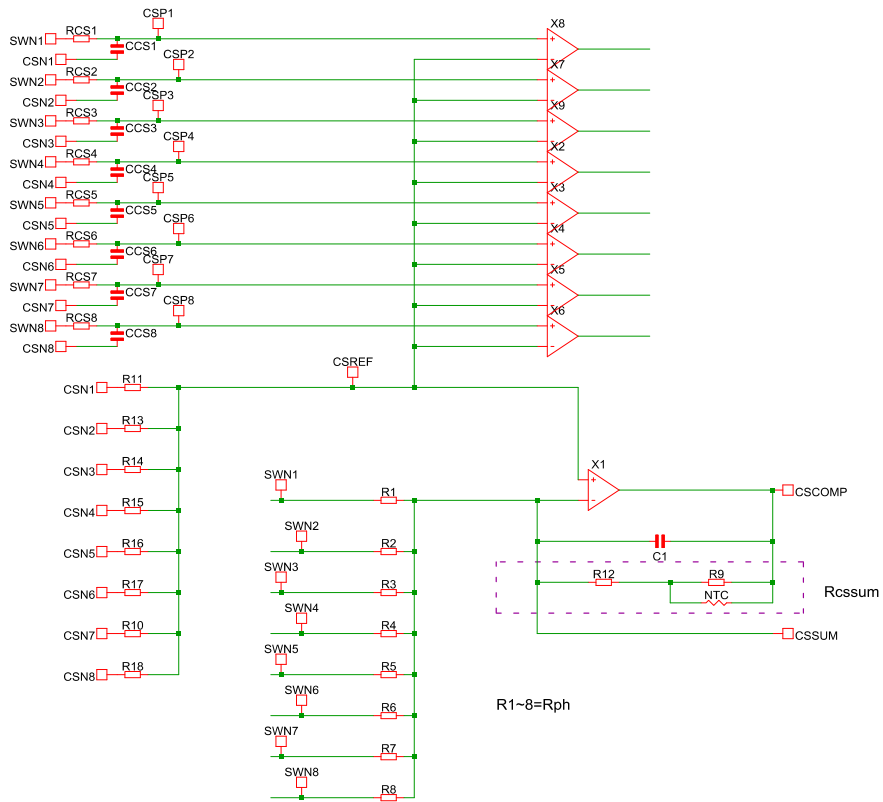

Figure 9. Total Current Summing Amplifier, DCR Sensing Example

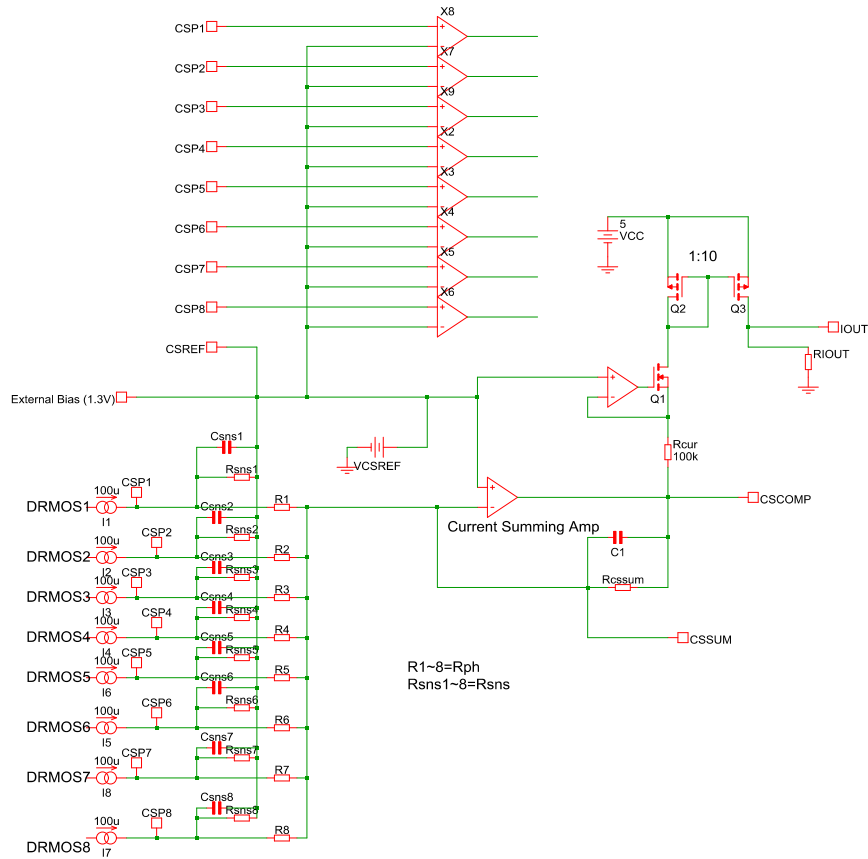

Figure 10. Total Current Summing Amplifier, Pseudo DCR Sensing Example



*Total Current Summing: DCR or Pseudo DCR Methods*

Two current summing methods in Figure 9, 10 are similar, they both convert the current signals drop across inductor DCR or DRMOS IMON current signal across a low value resistor to low impedance voltage signals and then sums them up with the current summing amplifier.

For DCR method,

$$CSREF - CSCOMP = I_{out} \cdot DCRL \cdot R_{csum}/R_{ph} \quad (eq. 9)$$

Where  $R_{csum} = R_{cs2} + R_{cs1} // NTC$ , and the pole frequency of CSCOMP filter needs to be selected to be equal to the zero frequency from the inductor DCRL, or  $R_{csum} * C1 = L / DCRL$  to recover the inductor DCR drop current signal.

For Pseudo DCR method,

$$CSREF - CSCOMP = I_{out} \cdot A_{ips} \cdot R_{sns} \cdot R_{csum}/R_{ph} \quad (eq. 10)$$

Where  $A_{ips}$  is the current sense gain of the power stage, and  $A_{ips} * R_{sns} = DCR_{ps}$  is the equivalent DCR.

The selection of IOUT resistor, and DROOP configuration are similar to the IMON sensing method in previous sections.

*Programming the Current Limit ILIM*

By default, per phase current limit threshold is programmed through an external shunt resistor of the ILIM pin on the fly.

$$R_{ILIM} = \frac{\text{perphase\_CLIM} \cdot DCR_{ps} \cdot 6}{10 \mu A} \quad (eq. 11)$$

Where  $DCR_{ps}$  is the equivalent DCR of the power stage, it can be inductor current sensing (DCRL) or DRMOS IMON sensing ( $A_{ips} * R_{pu}$ ) or DRMOS pseudo DCR sensing ( $A_{ips} * R_{sns}$ ).

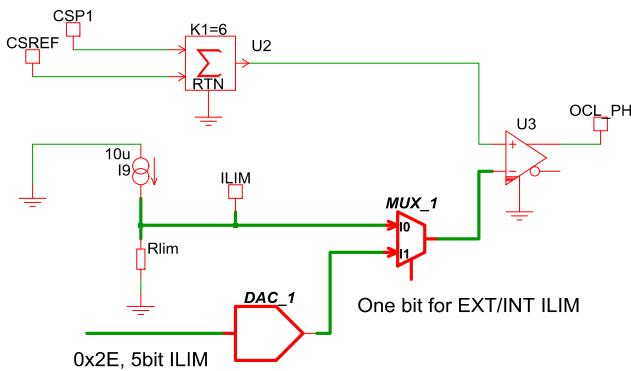

**Figure 11. External / Internal ILIM Setting**

During power on, a 10  $\mu A$  current is sourced from ILIM pin to generate ILIM voltage, it is sampled and stored into register 0x2D on the fly. As an option, the ILIM threshold can also be configured through an internal register 0x2E. The external ILIM voltage ranges from 0 V to 2 V. Internal ILIM value controlled by a 5 bit register (0x2E) has a range from 0.2 V to 1.75 V. One ILIM configuration bit in register

0x46 and 0x47 determines whether the external resistor value or internal register value is selected.

**Protections**

*TMON Monitoring*

External power stages can send signals with its own temperature information or other fault information through TMON pin. The TMON signal proportional to the corresponding power stage temperature usually ranges from 0 V to 2 V. When the power stage device is over heated or under other fault conditions, the signal will be pulled high to across TMON trigger threshold (0x4A, 2.0 V by default), NCP81610 will be able to detect this fault and force the system into two different subsequent states based on the TMON configuration register setting: latch up (by default), or timer based hiccup mode. The TMON fault can also be masked through register 0x22. Once masked, the controller will ignore TMON warning from the power stages.

*Overcurrent Limiting (OCL) and Undervoltage Protection (UVP)*

The device incorporates a per phase overcurrent limiting (OCL) mechanism to limit per phase current and the energy transferred from input to the output to protect against damage due to an over current event. The current limit threshold can be programmed with a shunt resistor on ILIM pin, as shown in the Programming the Current Limit ILIM section.

By default, OCL will always be functional, a large overcurrent event will pull the output below the Under Voltage Protection threshold (UVP) or 400 mV below REFIN to enforce a system latch up. Once latched up, the system will remain disabled until the EN pin is toggled.

VOCL\_min is a threshold level to allow the OCL function to be temporarily disabled when the output voltage is below the threshold; by default VOCL\_min function is disabled. If the VOCL\_min function is enabled during a current limiting event, the output will droop to the VOCL\_min threshold if UVP is disabled or VOCL\_min is set to above UVP threshold, OCL function will be disabled for a 2ms period to allow the system to go back to output voltage regulation. It is recommended that the system designer be aware of this over load condition to avoid per phase current exceeding the inductor saturation current.

VOCL\_min threshold can be configured through the I<sup>2</sup>C interface with a range of 0.2 V to 1.3 V and a 35 mV step resolution.

*Latched Mode Over-Current Protection (OCP)*

To prevent catastrophic system failure, NCP81610 is able to detect the total output current exceeding the overall current limit and force the chip to latch up. When current summing amplifier has its output CSCOMP voltage droop to less than 225 mV (CLIM), the system is considered as total current OCP and enter latched mode protection

## NCP81610

immediately with all the PWMs going to the mid-state, toggling EN is required to restart the system.

### *Under Voltage Lock-Out (VCC UVLO)*

VCC is constantly monitored for the under voltage lockout(UVLO). During power up the VCC pin are monitored Only after VCC exceeds its UVLO threshold will the full circuit be activated and ready for the soft start ramp.

### *Over Voltage Protection*

An output voltage monitor is incorporated into the controller. During normal operation, if the output voltage is 500 mV over the REFIN value, the PGOOD pin will be pulled low, the DRON will assert low and the PWM outputs are set low. The OVP limit will be clamped at 2 V if OVP is

disabled. The output will remain disabled until the EN pin is toggled.

### *VRMP (Line Input) Protection*

A line input voltage monitor is incorporated into the controller. During normal operation, if the line voltage is below the VRMP under voltage threshold (2.5 V), the system will be latched up. The output will remain disabled until the EN pin is toggled.

### *Over Temperature Shutdown (TSD)*

NCP81610 constantly monitors its own junction temperature during operation. If its temperature is over 150°C, an over-temperature fault will be reported. The system will either latch up, or enter into a timer based hiccup mode based on internal register (0x4B) settings.

**Table 5. REGISTER MAP**

| Address | R/W | Default Value | Description                       | Notes:                 |
|---------|-----|---------------|-----------------------------------|------------------------|
| 0x20    | R/W | 0xFF          | IOUT_OC_WARN_LIMIT                |                        |
| 0x21    | R   | 0x00          | STATUS BYTE                       |                        |
| 0x22    | R/W | 0x00          | FAULT MASK                        |                        |
| 0x23    | R   | 0x00          | STATUS Fault                      |                        |
| 0x24    | R   | 0x00          | STATUS Warning                    |                        |
| 0x26    | R   | 0x00          | READ_IOUT                         |                        |
| 0x27    | R   | 0x1A          | MFR_ID                            |                        |
| 0x28    | R   | 0x10          | MFR_MODEL                         |                        |
| 0x29    | R   |               | MFR_REVISION                      |                        |
| 0x2A    | R/W | 0x00          | Lock/Reset                        |                        |
| 0x2B    | R   | 0x00          | Soft Start status                 |                        |
| 0x2C    | N/A | 0x00          | Soft Start configuration          |                        |
| 0x2D    | R   |               | OCL status                        |                        |
| 0x2E    | R/W | 0x00          | OCL configuration                 |                        |
| 0x2F    | R   |               | Switching frequency status        |                        |
| 0x30    | R/W | 0x00          | Switching frequency configuration |                        |
| 0x31    | R/W | 0x01          | VID_DOWN enable                   |                        |
| 0x32    | R   |               | PSI status                        |                        |
| 0x33    | R   |               | Phase Status                      |                        |
| 0x34    | R/W | 0x1F          | LPC_Zone_enable                   |                        |
| 0x35    | R   |               | LPC status                        |                        |
| 0x36    | R/W | 0x03          | LPC configuration                 |                        |
| 0x38    | R   |               | LL status                         |                        |
| 0x39    | R/W | 0x03          | LL configuration                  | Default: Load disabled |
| 0x3A    | RW  | 0x00          | PHTH1 configuration               |                        |
| 0x3B    | R   |               | PHTH1 status                      |                        |
| 0x3C    | R/W | 0x00          | PHTH2 configuration               |                        |
| 0x3D    | R   |               | PHTH2 status                      |                        |

# NCP81610

**Table 5. REGISTER MAP** (continued)

| Address | R/W | Default Value | Description   | Notes: |
|---------|-----|---------------|---|--------|
| 0x3E    | R/W | 0x00          | PHTH3 configuration                                   |        |
| 0x3F    | R   |               | PHTH3 status  |        |
| 0x40    | R/W | 0x00          | PHTH4 configuration                                   |        |
| 0x41    | R   |               | PHTH4 status  |        |
| 0x44    | R/W | 0x08          | Phase shedding hysteresis                             |        |
| 0x45    | R/W | 0x14          | Phase shedding delay                                  |        |
| 0x46    | R/W | 0x00          | Second function configuration register latch A        |        |
| 0x47    | R/W | 0x00          | Second function configuration register latch B        |        |
| 0x48    | R   |               | READ_VOUT   |        |
| 0x49    | R   |               | READ_TMON   |        |
| 0x4A    | R/W | 0x00          | TMON_RESPONSE CONFIG                                  |        |
| 0x4B    | R/W | 0x00          | TSD_enable<br>TSD_fault response                      |        |
| 0x4C    | R/W | 0x00          | ZCD_CONFIG  |        |
| 0x4D    | R/W | 0x00          | ZCD_USER_TRIM   |        |
| 0x4E    | R/W | 0x00          | VOCL_min: Threshold to disable OCL<br>VOCL_min enable |        |
| 0x4F    | R/W | 0x00          | OVP CONFIGURATION                                     |        |
| 0x50    | R/W | 0x00          | UVP CONFIGURATION                                     |        |
| 0x51    | R/W | 0xFF          | TMON WARNING CONFIGURATION                            |        |
| 0x52    | R/W | 0x00          | CLEAR REG   |        |
| 0x53    | R/W | 0x00          | CONFIGURATION AUX                                     |        |

### *IOUT\_OC\_WARN\_LIMIT Register (0x20)*

8 bit register sets the threshold for IOUT voltage output and usually it is to monitor the total current. Once the READ\_IOUT register value exceeds this limit, the IOUT\_OC bit will be set in the STATUS BYTE register (0x21) and an ALERT is generated. Its default value is 0xFF.

### *STATUS BYTE Register (0x21)*

**Table 6. STATUS BYTE REGISTER SETTINGS**

| Bits | Name     | Description  |
|------|----------|--|
| 7    | TMON     | This bit gets set whenever TMON is over its set threshold.                         |
| 6    | TSD      | This bit gets set whenever NCP81610 exceeds its thermal shutdown temperature.      |
| 5    | VOUT_OV  | This bit gets set whenever the NCP81610 goes into OVP mode                         |
| 4    | IOUT_OC  | This bit gets set if READ_IOUT value is over the IOUT_OC_WARN_LIMIT register value |
| 0:3  | Reserved | N/A  |

# NCP81610

## Fault Mask Register (0x22)

**Table 7. FAULT MASK REGISTER SETTINGS (DEFAULT 0X00)**

| Bits | Name           | Description   |
|------|----------------|---|
| 7    | Reserved       |   |
| 6    | VRMP_UV        | Set to 1 means VRMP(VIN) under voltage will not trigger a latchup event but the fault will be reported in the fault status register |
| 5    | TMON           | Set to 1 means TMON fault will not trigger a latchup or hiccup event but the fault will be reported in the fault status register    |
| 4    | TSD            | Set to 1 means TSD fault will not trigger a latchup or hiccup event but the fault will be reported in the fault status register     |
| 3    | CLIM           | Set to 1 means CLIM_fault will not trigger a latchup or hiccup event but the fault will be reported in the fault status register    |
| 2    | per phase ILIM | Set to 1 means OCL per phase per phase current limiting function is disabled.   |
| 1    | OVP            | Set to 1 means OVP will not trigger a latchup event but the fault will be reported in the fault status register                     |
| 0    | UVP            | Set to 1 means UVP will not trigger a latchup event but the fault will be reported in the fault status register                     |

## STATUS Fault Register (0x23)

**Table 8. STATUS FAULT REGISTER SETTINGS**

| Bits | Name                 | Description                               |
|------|----------------------|---|
| 7    | Reserved             |   |
| 6    | VRMP_UV_fault        | VRMP (VIN) under voltage                  |
| 5    | TMON_fault           | TMON over threshold                       |
| 4    | TSD_fault            | NCP81610 over temperature                 |
| 3    | CLIM_fault           | CLIM fault                                |
| 2    | Per phase_ILIM_fault | Per phase current limiting (of any phase) |
| 1    | OVP_fault            | Overvoltage fault                         |
| 0    | UVP_fault            | Undervoltage fault                        |

## STATUS Warning Register (0x24)

**Table 9. STATUS WARNING REGISTER SETTINGS**

| Bits | Name                     | Description   |
|------|--------------------------|---|
| 7:1  | Reserved                 | N/A   |
| 0    | IOUT Overcurrent Warning | This bit sets if IOUT is over the warning value set by 0x20 |

## READ\_IOUT Register (0x26)

Read back output current. ADC conversion 0xff = 2 V on IOUT pin which should equate to max current.

# NCP81610

## Lock/Reset Register (0x2A)

**Table 10. LOCK/RESET REGISTER SETTINGS**

| Bits | Name           | Description  |
|------|----------------|--|
| 7:2  | Reserved       | N/A  |
| 1    | Software reset | Reserved   |
| 0    | Lock           | Logic 1 locks all limit values to their current settings. Once this bit is set, all lockable registers become read-only and cannot be modified until the NCP81610 is powered down and powered up again. This prevents rogue programs such as viruses from modifying critical system limit settings (Lockable). |

## Soft Start Status and Configuration Register (0x2B, 0x2C)

These registers contain the values that set the slew rate of the output voltage during power-up. When power on, the controller reads the value of the resistor connected to the PWM8/SS pin and sets the slew rate. The codes corresponding to each resistor setting are shown in Table 11. The soft start timer can be configured through 0x2C with 4bit resolution. One bit in control registers 0x46, 0x47 needs to be set to select internal soft start settings.

**Table 11. SOFT START STATUS AND CONFIGURATION REGISTER SETTINGS**

| t <sub>RAMP</sub> Resistor (kΩ) | Bits | Name     | Value | t <sub>RAMP</sub> (ms), REFIN = 1 V | t <sub>RAMP</sub> (ms), REFIN = 0.8 V |
|---------------------------------|------|----------|-------|-------------------------------------|---------------------------------------|
| –                               | 7:4  | Reserved | N/A   | N/A                                 | N/A                                   |
| 10                              | 3:0  | T_Ramp   | 0000  | 0.15                                | 0.12                                  |
| 14.7                            |      |          | 0001  | 0.3                                 | 0.24                                  |
| 20                              |      |          | 0010  | 0.45                                | 0.36                                  |
| 26.1                            |      |          | 0011  | 0.6                                 | 0.48                                  |
| 33.2                            |      |          | 0100  | 0.75                                | 0.6                                   |
| 41.2                            |      |          | 0101  | 0.9                                 | 0.72                                  |
| 49.9                            |      |          | 0110  | 1                                   | 0.8                                   |
| 60.4                            |      |          | 0111  | 2                                   | 1.6                                   |
| 71.5                            |      |          | 1000  | 3                                   | 2.4                                   |
| 84.5                            |      |          | 1001  | 4                                   | 3.2                                   |
| 100                             |      |          | 1010  | 5                                   | 4                                     |
| 118.3                           |      |          | 1011  | 6                                   | 4.8                                   |
| 136.6                           |      |          | 1100  | 7                                   | 5.6                                   |
| 157.7                           |      |          | 1101  | 8                                   | 6.4                                   |
| 182.1                           |      |          | 1110  | 9                                   | 7.2                                   |
| 249                             |      |          | 1111  | 10                                  | 8                                     |

## NCP81610

### *OCL\_ILIM Status Register and Configuration Register (0x2D, 0x2E)*

These registers contain per phase current limit (OCL\_ILIM) status and configuration information. By default, a 10  $\mu$ A constant current will be sourced to the external ILIM resistor and read back the OCL\_ILIM threshold level on the fly. OCL\_ILIM threshold can also be dynamically configured by 0x2E register with 5bit resolution. One bit in registers 0x46, 0x47 needs to be set to select internal OCL setting shown in Table 13. When one phase is in OCL mode, the corresponding register bit will be set in 0x2D.

**Table 12. OCL\_ILIM STATUS REGISTER SETTINGS (0X2D)**

| Bits | Name          | Description  |
|------|---------------|--|
| 7:0  | Per phase OCL | Bit 7: Phase 8 current limit triggered.<br>.<br>.<br>Bit 0: Phase 1 current limit triggered. |

**Table 13. OCL\_ILIM CONFIGURATION REGISTER SETTINGS (0X2E)**

| Bits | Name                        | Description  |
|------|-----------------------------|--|
| 7:5  | Reserved                    | N/A  |
| 4:0  | Per phase OCL configuration | Configure the threshold for per phase current limit.<br>0x00: 0.2 V<br>0x01: 0.25 V<br>...<br>0x1F: 1.75 V |

# NCP81610

## Switching Frequency Status and Configuration Registers (0x2F, 0x30)

These registers contain the values that set the switching frequency of the controller. When power on, the controller reads the value of the resistor connected to the FSW pin and sets the switching frequency according to Table 14. The codes corresponding to each setting are also shown in Table 14.

The switching frequency configuration register allows the user to dynamically change the switching frequency through the I<sup>2</sup>C interface provided that the FSW bits from the second function configuration registers A and B (0x46, 0x47) are set.

**Table 14. SWITCHING FREQUENCY STATUS AND CONFIGURATION REGISTER SETTINGS**

| FSW Pin Resistor Value (kΩ) | Bits  | Value              |                        | Switching Frequency (kHz) |         |         |         |         |         |         |         |
|-----------------------------|-------|--------------------|------------------------|---------------------------|---------|---------|---------|---------|---------|---------|---------|
|                             |       | Status Register    | Configuration Register | 8 Phase                   | 7 Phase | 6 Phase | 5 Phase | 4 Phase | 3 Phase | 2 Phase | 1 Phase |
|                             | 7:5   | Reserved           | Reserved               | N/A                       | N/A     | N/A     | N/A     | N/A     | N/A     | N/A     | N/A     |
| 10                          | 4:0   | 00000<br>(default) | 00000                  | 221                       | 253     | 295     | 355     | 221     | 293     | 223     | 232     |
|                             |       | -                  | 00001                  | 244                       | 276     | 330     | 399     | 244     | 329     | 243     | 252     |
| 14.7                        |       | 00010              | 00010                  | 266                       | 309     | 355     | 425     | 266     | 358     | 264     | 272     |
|                             |       | -                  | 00011                  | 293                       | 327     | 387     | 460     | 293     | 381     | 294     | 297     |
| 20                          |       | 00100              | 00100                  | 307                       | 351     | 412     | 501     | 307     | 407     | 317     | 322     |
|                             |       | -                  | 00101                  | 333                       | 384     | 441     | 542     | 333     | 450     | 335     | 340     |
| 26.1                        |       | 00110              | 00110                  | 351                       | 409     | 480     | 561     | 351     | 480     | 352     | 361     |
|                             |       | -                  | 00111                  | 373                       | 431     | 499     | 615     | 373     | 510     | 380     | 385     |
| 33.2                        |       | 01000              | 01000                  | 394                       | 451     | 528     | 639     | 394     | 530     | 399     | 413     |
|                             |       | -                  | 01001                  | 421                       | 481     | 559     | 676     | 421     | 562     | 420     | 435     |
| 41.2                        |       | 01010              | 01010                  | 449                       | 495     | 593     | 725     | 449     | 600     | 436     | 456     |
|                             |       | -                  | 01011                  | 469                       | 525     | 612     | 746     | 469     | 614     | 454     | 478     |
| 49.9                        |       | 01100              | 01100                  | 479                       | 563     | 639     | 757     | 479     | 631     | 483     | 500     |
|                             |       | -                  | 01101                  | 509                       | 570     | 681     | 799     | 509     | 663     | 508     | 509     |
| 60.4                        |       | 01110              | 01110                  | 518                       | 588     | 697     | 831     | 518     | 688     | 526     | 518     |
|                             |       | -                  | 01111                  | 543                       | 617     | 722     | 874     | 543     | 722     | 543     | 540     |
| 71.5                        |       | 10000              | 10000                  | 581                       | 665     | 779     | 930     | 581     | 789     | 583     | 578     |
|                             |       | -                  | 10001                  | 649                       | 718     | 881     | 1043    | 649     | 859     | 656     | 638     |
| 84.5                        |       | 10010              | 10010                  | 708                       | 790     | 937     | 1129    | 708     | 930     | 698     | 698     |
|                             |       | -                  | 10011                  | 751                       | 868     | 1010    | 1211    | 751     | 1010    | 771     | 758     |
| 100                         | 10100 | 10100              | 799                    | 918                       | 1073    | 1278    | 799     | 1095    | 807     | 818     |         |
|                             | -     | 10101              | 866                    | 1003                      | 1136    | 1372    | 866     | 1147    | 860     | 878     |         |
| 118.3                       | 10110 | 10110              | 919                    | 1025                      | 1220    | 1449    | 919     | 1233    | 899     | 938     |         |
|                             | -     | 10111              | 964                    | 1111                      | 1297    | 1533    | 964     | 1260    | 950     | 972     |         |
| 136.6                       | 11000 | 11000              | 993                    | 1140                      | 1339    | 1671    | 993     | 1341    | 1003    | 1014    |         |
|                             | -     | 11001              | 1059                   | 1198                      | 1438    | 1687    | 1059    | 1372    | 1052    | 1067    |         |
| 157.7                       | 11010 | 11010              | 1098                   | 1262                      | 1485    | 1734    | 1098    | 1450    | 1096    | 1106    |         |
|                             | -     | 11011              | 1141                   | 1295                      | 1533    | 1821    | 1141    | 1539    | 1154    | 1155    |         |
| 182.1                       | 11100 | 11100              | 1200                   | 1338                      | 1587    | 1953    | 1200    | 1619    | 1205    | 1201    |         |
|                             | -     | 11101              | 1236                   | 1405                      | 1608    | 1954    | 1236    | 1618    | 1227    | 1245    |         |
| 249                         | 11110 | 11110              | 1291                   | 1459                      | 1707    | 2012    | 1291    | 1674    | 1274    | 1280    |         |
|                             | -     | 11111              | 1312                   | 1493                      | 1724    | 2096    | 1312    | 1724    | 1316    | 1330    |         |

## NCP81610

### *VID DOWN Enable Register (0x31)*

One control bit to enable or disable VID DOWN phase operation change during DCM mode.

**Table 15. STATUS BYTE REGISTER SETTINGS**

| Bits | Name            | Description   |
|------|-----------------|---|
| 7:1  | Reserved        | N/A   |
| 0    | VID DOWN enable | 0: VID DOWN change disabled<br>1 (default): VID DOWN change enabled |

### *PSI Status Register (0x32)*

The PSI status register provides the information regarding the current status of the PSI pin through the I<sup>2</sup>C interface as shown in Table 16.

**Table 16. PSI STATUS REGISTER SETTINGS**

| Bits | Name            | Description             |
|------|-----------------|-------------------------|
| 7:2  | Reserved        | N/A                     |
| 1:0  | PSI input level | 00 = PSI MID (Auto PSI) |
|      |                 | 01 = PSI LOW            |
|      |                 | 10 = PSI HIGH           |

### *Phase Status Register (0x33)*

The Phase Status register provides the information about the status of each of the eight available phases as shown in Table 17.

**Table 17. PHASE STATUS REGISTER SETTINGS**

| Bits | Name    | Description  |
|------|---------|--------------|
| 7    | Phase 8 | 0 = Disabled |
|      |         | 1 = Enabled  |
| 6    | Phase 7 | 0 = Disabled |
|      |         | 1 = Enabled  |
| 5    | Phase 6 | 0 = Disabled |
|      |         | 1 = Enabled  |
| 4    | Phase 5 | 0 = Disabled |
|      |         | 1 = Enabled  |
| 3    | Phase 4 | 0 = Disabled |
|      |         | 1 = Enabled  |
| 2    | Phase 3 | 0 = Disabled |
|      |         | 1 = Enabled  |
| 1    | Phase 2 | 0 = Disabled |
|      |         | 1 = Enabled  |
| 0    | Phase 1 | 0 = Disabled |
|      |         | 1 = Enabled  |



## NCP81610

### *LPC\_Zone\_Enable Register (0x34)*

The LPC\_Zone\_enable register allows the user to enable or disable power zones while the controller has the PSI set low using the I<sup>2</sup>C interface as shown in Table 18.

**Table 18. LPC\_ZONE\_ENABLE REGISTER SETTINGS**

| Bits | Name     | Description          |
|------|----------|----------------------|
| 7:5  | Reserved | N/A                  |
| 4    | Zone 5   | 0 = Disabled         |
|      |          | 1(default) = Enabled |
| 3    | Zone 4   | 0 = Disabled         |
|      |          | 1(default) = Enabled |
| 2    | Zone 3   | 0 = Disabled         |
|      |          | 1(default) = Enabled |
| 1    | Zone 2   | 0 = Disabled         |
|      |          | 1(default) = Enabled |
| 0    | Zone 1   | 0 = Disabled         |
|      |          | 1(default) = Enabled |

### *LPC Status and Configuration Registers (0x35, 0x36)*

These registers contain the values that set the operating power zone when the PSI pin is set low. When power on, the controller reads the value of the resistor connected to the PWM6/LPC1 and PWM5/LPC2 pins and sets the power zone according to Table 3. The codes corresponding to each setting are shown in Table 19.

The LPC configuration register allows the user to dynamically change the power zone (PSI = low) through the I<sup>2</sup>C interface provided that the LPC bits from the second function configuration registers A and B (0x46, 0x47) are set. The achievable power zone settings are listed in Table 19.

**Table 19. LPC STATUS AND CONFIGURATION REGISTER SETTINGS**

| Bits           | Name               | Value          | Level              |
|----------------|--------------------|----------------|--------------------|
| 7:6            | Reserved           | N/A            | N/A                |
| 5:3            | LPC1 configuration | 000 (default)  | 0                  |
|                |                    | 001            | 1                  |
|                |                    | 010            | 2                  |
|                |                    | 011            | 3                  |
|                |                    | 100            | 4                  |
|                |                    | 101 = Reserved | N/A                |
|                |                    | 111 = Reserved | N/A                |
|                |                    | 2:0            | LPC2 configuration |
| 001            | 1                  |                |                    |
| 010            | 2                  |                |                    |
| 011            | 3                  |                |                    |
| 100*           | 3                  |                |                    |
| 101 = Reserved | N/A                |                |                    |
| 110 = Reserved | N/A                |                |                    |
| 111 = Reserved | N/A                |                |                    |

# NCP81610

## Load Line Configuration Registers (0x39)

This register contains the value that set the fraction of the externally configured load line (LL) to be used during the normal operation of the device. The codes corresponding to each setting are shown in Table 20. The LL configuration register allows the user to dynamically change the load line settings through the I<sup>2</sup>C. By default, the load line is disabled.

**Table 20. LL STATUS AND CONFIGURATION REGISTERS SETTINGS**

| Bits | Description                                   |
|------|---|
| 7:2  | Reserved                                      |
| 1:0  | 00 = 100% of externally set load line         |
|      | 01 = 50% of externally set load line          |
|      | 10 = 25% of externally set load line          |
|      | 11 (default) = 0% of externally set load line |

## PHTH1 to PHTH4 Configuration Registers (0x3A, 0x3C, 0x3E, 0x40)

These 8 bit registers contain the values that control the phase shedding thresholds and are active when the PHTH<sub>X</sub> bits from the second function configuration registers A and B (0x46 and 0x47) are set. These thresholds allow the user to dynamically change the thresholds through the I<sup>2</sup>C interface. The values written to these registers should match the value of the READ\_IOUT register (0x26) at the desired load current. If 0xFF is written to a register, the phase shedding threshold corresponding to that register is disabled.

## PHTH1 to PHTH4 Status Registers (0x3B, 0x3D, 0x3F, 0x41)

These 8 bit registers contain the phase shedding threshold values set by the resistors connected to the PHTH<sub>X</sub> pins. The values of the thresholds are updated during the power on period. The resistor values should be chosen to ensure that the voltage drop across them developed by the 10 μA current sourced by the NCP81610 during power-up (EN set high) matches the value of the READ\_IOUT register (0x26) at the desired load current. Setting the resistors to generate a voltage above 2 V will disable the PHTH<sub>X</sub> threshold for that pin.

## Phase Shedding Hysteresis Register (0x44)

This register sets the hysteresis during a transition from a high count phase to a low count phase configuration. The hysteresis is expressed in codes (LSBs) of the PHTH<sub>X</sub> threshold values.

## Phase Shedding Delay Register (0x45)

This register sets the delay during a transition from a high count phase to a low count phase configuration. The power-up default value is 200 μs (14H) and it can be dynamically changed in steps of 30 μs (1 LSB) through the I<sup>2</sup>C interface.

# NCP81610

## Second Function Configuration Register Latch A and B Registers (0x46, 0x47)

These registers allow the user to select whether the second functions settings (FSW, Soft Start, OCL, LPC and PHTH<sub>X</sub>) are controlled by the external resistors or the configuration registers (see Table 21). When power on and enabled (cold start), the default control mode for the functions is the external resistor. Switching between the two modes can be done by simply writing the appropriate byte (the same byte) to both registers (the order doesn't matter).

**Table 21. SECOND CONFIGURATION LATCH REGISTER A AND B**

| Bits | Second Function Configuration Register | Description  |
|------|--|--|
| 7:6  | Reserved                               | N/A  |
| 5    | FSW                                    | 0 (default) = switching frequency set by external resistor                               |
|      |  | 1 (default) = switching frequency set by register 0x30                                   |
| 4    | Reserve                                | Reserve  |
| 3    | Soft Start Timer                       | 0 (default) = soft start timer set by external resistor                                  |
|      |  | 1 (default) = soft start timer set by register 0x2C                                      |
| 2    | OCL_ILIM                               | 0 (default) = per phase current limit set by external resistor                           |
|      |  | 1 = per phase current limit set by register 0x2E   |
| 1    | LPC1,LPC2                              | 0 (default) = low power zone set by external resistor                                    |
|      |  | 1 = low power zone set by register 0x36  |
| 0    | PHTH <sub>X</sub>                      | 0 (default) = set by external resistors connected between PHTH <sub>X</sub> pins and GND |
|      |  | 1 = set by registers 0x3A, 0x3C, 0x3E and 0x40   |

## VMON Register (0x48)

8 bit register to monitor VSP – VSN differential voltage value (Max FFH, 2 V).

## TMON External Power Stage Thermal Monitoring Register (0x49)

8 bit register to monitor external power stage thermal temperature (Max FFH, 2 V).

## TMON Fault Response Configuration Register (0x4A)

**Table 22. TMON CONFIGURATION THRESHOLD**

| Bits | Name                | Description                 |
|------|---------------------|-----------------------------|
| 7:1  | Reserved            | N/A                         |
| 0    | TMON fault response | 0 (default): Latch response |
|      |                     | 1: Hiccup mode              |

## TSD Fault Threshold / Response Configuration Register (0x4B)

**Table 23. TSD CONFIGURATION THRESHOLD**

| Bits | Name               | Description                                 |
|------|--------------------|---|
| 7:2  | Reserved           | N/A   |
| 1    | TSD enable         | 0 (default): TSD disabled<br>1: TSD enabled |
| 0    | TSD fault response | 0 (default): Latch response                 |
|      |                    | 1: Hiccup mode                              |

# NCP81610

## ZCD Configuration Register (0x4C)

**Table 24. ZCD CONFIGURATION REGISTER**

| Bits | Name                        | Description                                 |
|------|-----------------------------|---|
| 7:3  | Reserved                    | N/A   |
| 2    | ZCD PWM level configuration | 0 (default): PWM = H/L                      |
|      |                             | 1: PWM = H/M, PWM can go to Mid state       |
| 1    | ZCD reset                   | Default 0: reset ZCD threshold              |
| 0    | ZCD disable                 | 0 (default): ZCD enabled<br>1: ZCD disabled |

## ZCD User Trim Register (0x4D)

Allow user to set their own ZCD threshold values.

**Table 25. ZCD USER TRIM REGISTER**

| Bits | Name               | Description  |
|------|--------------------|--|
| 7:6  | Reserved           | N/A  |
| 5:0  | Trim ZCD threshold | 0x111111: +18.6 mV<br>0x100000: +0.6 mV<br>0x000000 (Default): 0 mV<br>0x000001: -0.6 mV<br>0x011111: -18.6 mV |

## VOCL\_Min Configuration Register (0x4E)

VOUT per phase OCL disable threshold values relative to DIFFOUT. VOCL\_min function can be disabled by bit 0.

**Table 26. VOCL\_MIN CONFIGURATION REGISTER**

| Bits | Name               | Description   |
|------|--------------------|---|
| 5:1  | VOCL_min threshold | 5 bit, with 35 mV resolution<br>00000 (default): 0.215 V<br>00001: 0.250 V<br>...<br>11111: 1.3 V |
| 0    | VOCL_min enable    | 0 (default): VOCL_min disabled<br>1: VOCL_min enable  |

## OVP Configuration Register (0x4F)

OVP can be changed by this register with 50 mV resolution.

**Table 27. OVP\_CONFIGURATION REGISTER**

| Bits | Name     | Description  |
|------|----------|--|
| 7:3  | Reserved |  |
| 2:0  | OVPth    | 000 (default): typ: 600 mV, min: 500 mV<br>001: +50 mV<br>010: +100 mV<br>011: +150 mV<br>100: OVP Clamped to 2.0 V<br>101: -50 mV<br>110: -100 mV<br>111: -150 mV |

## NCP81610

### UVP Configuration Register (0x50)

UVP configuration can be changed by this register with 50 mV resolution.

**Table 28. UVP\_THRESHOLD REGISTER**

| Bits | Name     | Description  |
|------|----------|--|
| 7:3  | Reserved |  |
| 2:0  | UVPth    | 000 (default): max: -400 mV; typ: -500 mV<br>001: -50 mV<br>010: -100 mV<br>011: -150 mV<br>100: UVP disabled<br>101: +50 mV<br>110: +100 mV<br>111: +150 mV |

### TMON Warning Threshold Register (0x51)

TMON warning threshold is usually less than TMON fault threshold.

**Table 29. TMON WARNING THRESHOLD REGISTER**

| Bits | Name                   | Description  |
|------|------------------------|--|
| 7:0  | TMON WARNING threshold | Default 0xFF or ~ 2.0 V,<br>0x00: 0 V<br>0x01: 0.008 V<br>...<br>0x0F: 2.040 V |

### Clear\_Reg Register (0x52)

Clear\_reg register is used to reset the OCP\_ILIM status register by transition from “0” to “1”.

**Table 30. CLEAR\_REG REGISTER**

| Bits | Name      | Description   |
|------|-----------|---|
| 7:1  | Reserved  | N/A   |
| 0    | Clear_Reg | Bit 0 Transition from 0 to 1 cause the reset of OCP_ILIM status register (0x2D). Please notice that this register remain writable even the lock bit has been set. |

### Auxiliary Configuration Register (0x53)

**Table 31. AUXILIARY CONFIGURATION REGISTER**

| Bits | Name            | Description   |
|------|-----------------|---|
| 7:4  | Reserved        | N/A   |
| 3    | SONIC_TMR_EN    | 0 (default): Ultrasonic timer disabled<br>1: Ultrasonic timer enabled                 |
| 2    | I2C_or_fuse_sel | 0 (default): select fuse settings<br>1: select I <sup>2</sup> C settings              |
| 1    | CLIM_sel        | 0 (default): CSCOMP < 0.225 V trigger CLIM<br>1: CSREFE - CSCOMP > 1.0 V trigger CLIM |
| 0    | TBD             | TBD   |

# MECHANICAL CASE OUTLINE

## PACKAGE DIMENSIONS

ON Semiconductor®

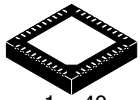

1 40

SCALE 2:1

**QFN40 5x5, 0.4P**  
CASE 485CR  
ISSUE C

DATE 27 AUG 2013

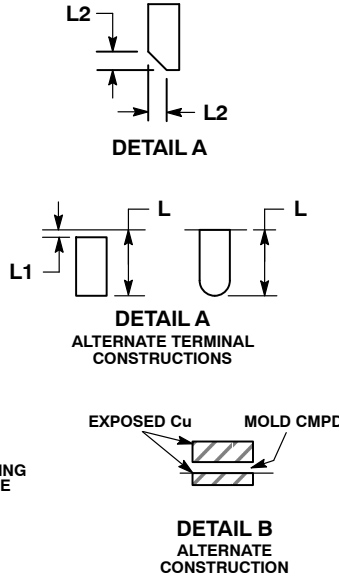
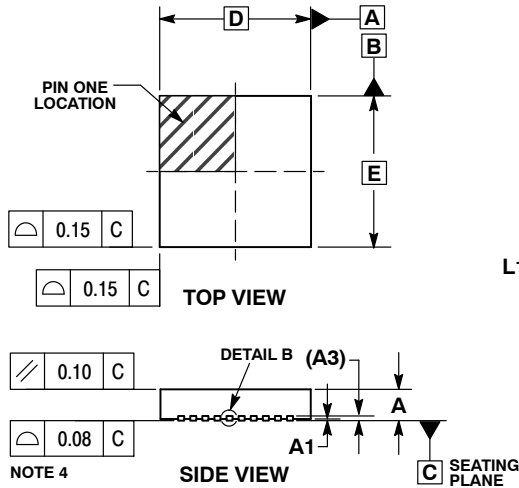

**NOTES:**

1. DIMENSIONING AND TOLERANCING PER ASME Y14.5M, 1994.
2. CONTROLLING DIMENSIONS: MILLIMETERS.
3. DIMENSION b APPLIES TO PLATED TERMINAL AND IS MEASURED BETWEEN 0.15 AND 0.30mm FROM THE TERMINAL TIP.
4. COPLANARITY APPLIES TO THE EXPOSED PAD AS WELL AS THE TERMINALS.

| MILLIMETERS |      |      |
|-------------|------|------|
| DIM         | MIN  | MAX  |
| A           | 0.80 | 1.00 |
| A1          | ---  | 0.05 |
| A3          | 0.20 | REF  |
| b           | 0.15 | 0.25 |
| D           | 5.00 | BSC  |
| D2          | 3.40 | 3.60 |
| E           | 5.00 | BSC  |
| E2          | 3.40 | 3.60 |
| e           | 0.40 | BSC  |
| L           | 0.30 | 0.50 |
| L1          | ---  | 0.15 |
| L2          | 0.12 | REF  |

**GENERIC MARKING DIAGRAM\***

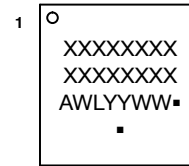

- XXXXXX = Specific Device Code
- A = Assembly Location
- WL = Wafer Lot
- YY = Year
- WW = Work Week
- = Pb-Free Package

(Note: Microdot may be in either location)

\*This information is generic. Please refer to device data sheet for actual part marking.

Pb-Free indicator, "G" or microdot "■", may or may not be present.

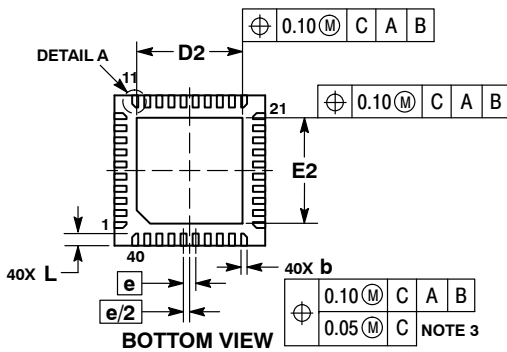

**RECOMMENDED SOLDERING FOOTPRINT**

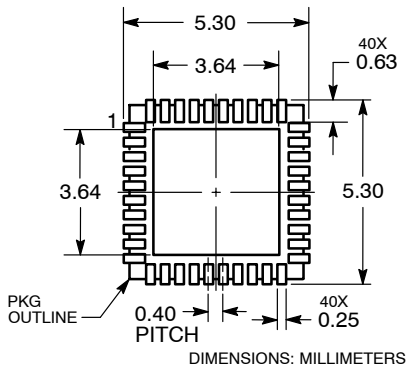

|                         |                         |  |
|-------------------------|-------------------------|--|
| <b>DOCUMENT NUMBER:</b> | <b>98AON83971E</b>      | Electronic versions are uncontrolled except when accessed directly from the Document Repository. Printed versions are uncontrolled except when stamped "CONTROLLED COPY" in red. |
| <b>DESCRIPTION:</b>     | <b>QFN40, 5x5, 0.4P</b> | <b>PAGE 1 OF 1</b>   |

ON Semiconductor and ON are trademarks of Semiconductor Components Industries, LLC dba ON Semiconductor or its subsidiaries in the United States and/or other countries. ON Semiconductor reserves the right to make changes without further notice to any products herein. ON Semiconductor makes no warranty, representation or guarantee regarding the suitability of its products for any particular purpose, nor does ON Semiconductor assume any liability arising out of the application or use of any product or circuit, and specifically disclaims any and all liability, including without limitation special, consequential or incidental damages. ON Semiconductor does not convey any license under its patent rights nor the rights of others.

**onsemi**, **Onsemi**, and other names, marks, and brands are registered and/or common law trademarks of Semiconductor Components Industries, LLC dba "**onsemi**" or its affiliates and/or subsidiaries in the United States and/or other countries. **onsemi** owns the rights to a number of patents, trademarks, copyrights, trade secrets, and other intellectual property. A listing of **onsemi**'s product/patent coverage may be accessed at [www.onsemi.com/site/pdf/Patent-Marking.pdf](http://www.onsemi.com/site/pdf/Patent-Marking.pdf). **onsemi** reserves the right to make changes at any time to any products or information herein, without notice. The information herein is provided "as-is" and **onsemi** makes no warranty, representation or guarantee regarding the accuracy of the information, product features, availability, functionality, or suitability of its products for any particular purpose, nor does **onsemi** assume any liability arising out of the application or use of any product or circuit, and specifically disclaims any and all liability, including without limitation special, consequential or incidental damages. Buyer is responsible for its products and applications using **onsemi** products, including compliance with all laws, regulations and safety requirements or standards, regardless of any support or applications information provided by **onsemi**. "Typical" parameters which may be provided in **onsemi** data sheets and/or specifications can and do vary in different applications and actual performance may vary over time. All operating parameters, including "Typicals" must be validated for each customer application by customer's technical experts. **onsemi** does not convey any license under any of its intellectual property rights nor the rights of others. **onsemi** products are not designed, intended, or authorized for use as a critical component in life support systems or any FDA Class 3 medical devices or medical devices with a same or similar classification in a foreign jurisdiction or any devices intended for implantation in the human body. Should Buyer purchase or use **onsemi** products for any such unintended or unauthorized application, Buyer shall indemnify and hold **onsemi** and its officers, employees, subsidiaries, affiliates, and distributors harmless against all claims, costs, damages, and expenses, and reasonable attorney fees arising out of, directly or indirectly, any claim of personal injury or death associated with such unintended or unauthorized use, even if such claim alleges that **onsemi** was negligent regarding the design or manufacture of the part. **onsemi** is an Equal Opportunity/Affirmative Action Employer. This literature is subject to all applicable copyright laws and is not for resale in any manner.

## PUBLICATION ORDERING INFORMATION

### LITERATURE FULFILLMENT:

Email Requests to: [orderlit@onsemi.com](mailto:orderlit@onsemi.com)

**onsemi Website:** [www.onsemi.com](http://www.onsemi.com)

### TECHNICAL SUPPORT

**North American Technical Support:**

Voice Mail: 1 800-282-9855 Toll Free USA/Canada

Phone: 011 421 33 790 2910

**Europe, Middle East and Africa Technical Support:**

Phone: 00421 33 790 2910

For additional information, please contact your local Sales Representative