

NCP81166, NCP81166A

Synchronous Buck MOSFET Drivers

The NCP81166/A is a high performance dual MOSFET gate driver optimized to drive the gates of both high-side and low-side power MOSFETs in a synchronous buck converter. 2mm x 2mm DFN8 package allows for space-optimized board layout.

Zero current detect feature allows for a high-efficiency solution even at light load conditions. Pre-OVP feature aids in protecting the load in the event of a short across the high-side FET. V_{CC} UVLO ensures the MOSFETs are off when supply voltages are low. A bi-directional Enable pin provides a fault signal to the controller when a pre-OVP or UVLO fault is detected.

Features

- Space-Efficient 2 mm x 2mm DFN8 Thermally-Enhanced Package
- V_{CC} Range of 4.5 V to 13.2 V
- Integrated Bootstrap Diode
- Pre-OVP Function Protects Load during HS FET Short
 - ◆ NCP81166: 2.25 V SW Trip Threshold
 - ◆ NCP81166A: 1.8 V SW Trip Threshold
- Zero Current Detect Function Provides Power Saving Operation during Light Load Conditions
- Bi-directional Enable Feature pulls Enable pin low during pre-OVP and UVLO Faults
- 5 V tri-state PWM Logic
- Adaptive Anti-Cross-Conduction Circuit Protects against Cross-Conduction during FET turn-on and turn-off
- Output Disable Control turns off both MOSFETs via Enable pin
- VCC Undervoltage Lockout
- Direct interface to ASP1252, ASP1400 and other compatible PWM Controllers
- These Devices are Pb-Free, Halogen Free/BFR Free and are RoHS Compliant

Typical Applications

- Power Solutions for Desktop Systems



ON Semiconductor®

<http://onsemi.com>



**DFN8
MN SUFFIX
CASE 506CN**

MARKING DIAGRAM

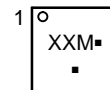

XX = Specific Device Code
CE for NCP81166
CH for NCP81166A

M = Date Code
▪ = Pb-Free Device

(Note: Microdot may be in either location)

ORDERING INFORMATION

Device	Package	Shipping†
NCP81166MNTBG	DFN8 (Pb-Free)	3000 / Tape & Reel
NCP81166AMNTBG	DFN8 (Pb-Free)	3000 / Tape & Reel

†For information on tape and reel specifications, including part orientation and tape sizes, please refer to our Tape and Reel Packaging Specification Brochure, BRD8011/D.

NCP81166, NCP81166A

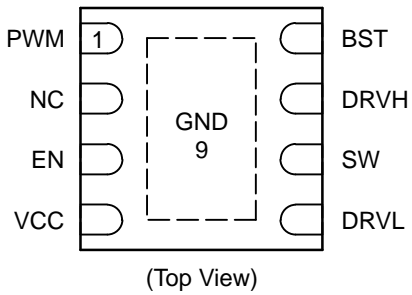

Figure 1. Pin Diagram



Figure 2. Block Diagram

Table 1. Pin Descriptions

Pin No.	Symbol	Description
1	PWM	Control input. The PWM signal has three distinctive states: Low = Low Side FET Enabled, Mid = Diode Emulation Enabled, High = High Side FET Enabled.
2	NC	No connect. There is no electrical connection from this pin to the die. Externally connecting this pin to ground will not affect the functionality of the part.
3	EN	Logic input. A logic high to enable the part and a logic low to disable the part. Pin is internally pulled low during pre-OVP and UVLO faults.
4	VCC	Power supply input. Connect a bypass capacitor (1 μ F) from this pin to ground.
5	DRVL	Low side gate drive output. Connect to the gate of low side MOSFET.
6	SW	Switch node. Connect this pin to the source of the high side MOSFET and drain of the low side MOSFET.
7	DRVH	High side gate drive output. Connect to the gate of high side MOSFET.
8	BST	Floating bootstrap supply pin for high side gate driver. Connect the bootstrap capacitor between this pin and the SW pin.
9	GND	Bias and reference ground. All signals are referenced to this node.

NCP81166, NCP81166A

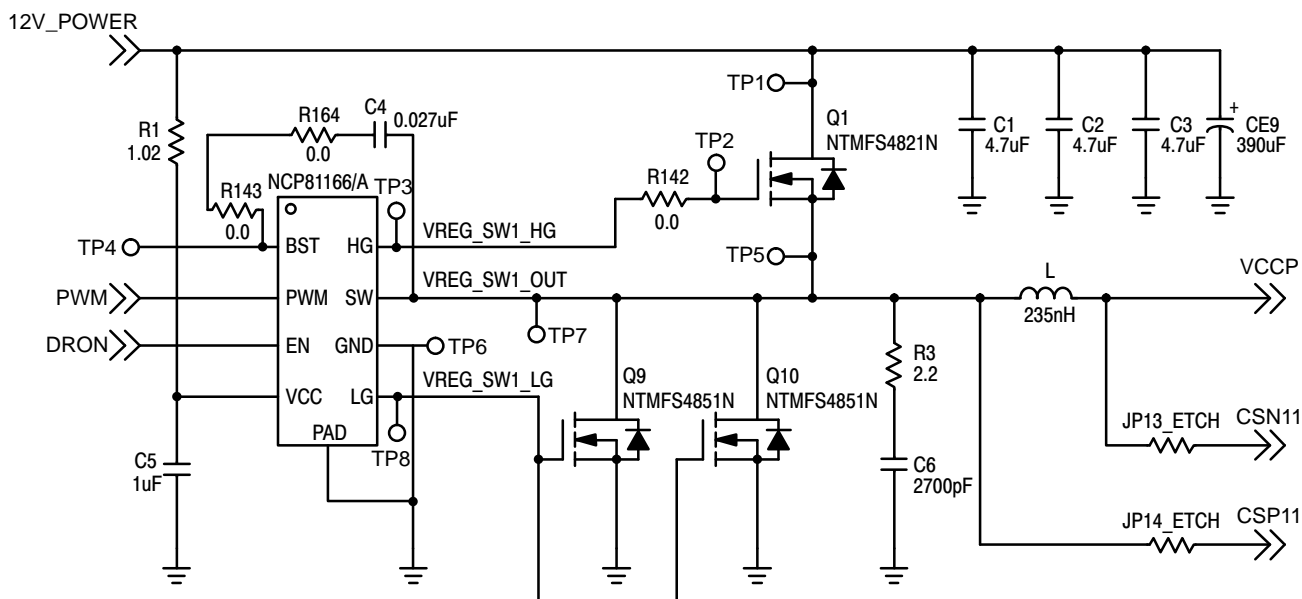

Figure 3. Application Circuit

Table 2. ABSOLUTE MAXIMUM RATINGS

Pin Symbol	Pin Name	V _{MAX}	V _{MIN}
VCC	Main Supply Voltage Input	15 V	-0.3 V
BST	Bootstrap Supply Voltage	35 V wrt/ GND 40 V ≤ 50 ns wrt/ GND 15 V wrt/ SW	-0.3 V wrt/SW
SW	Switching Node (Bootstrap Supply Return)	35 V 40 V ≤ 50 ns	-5 V -10 V (200 ns)
DRVH	High Side Driver Output	BST+0.3 V	-0.3 V wrt/SW -2 V (<200 ns) wrt/SW
DRVL	Low Side Driver Output	VCC+0.3 V	-0.3 V DC -5 V (<200 ns)
PWM	DRVH and DRVL Control Input	6.5 V	-0.3 V
EN	Enable Pin	6.5 V	-0.3 V
GND	Ground	0 V	0 V

Stresses exceeding Maximum Ratings may damage the device. Maximum Ratings are stress ratings only. Functional operation above the Recommended Operating Conditions is not implied. Extended exposure to stresses above the Recommended Operating Conditions may affect device reliability.

Table 3. THERMAL INFORMATION (All signals referenced to AGND unless noted otherwise)

Symbol	Parameter	Value	Unit
R _{θJA}	Thermal Characteristic (Note 1)	74	°C/W
T _J	Operating Junction Temperature Range* (Note 2)	-40 to 150	°C
T _A	Operating Ambient Temperature Range*	-10 to +125	°C
T _{STG}	Maximum Storage Temperature Range	-55 to +150	°C
MSL	Moisture Sensitivity Level	1	

* The maximum package power dissipation must be observed.

1. 1 in² Cu, 1 oz thickness.

2. Operation at -40°C to -10°C guaranteed by design, not production tested.

NCP81166, NCP81166A

Table 4. ELECTRICAL CHARACTERISTICS (Unless otherwise stated: $-10^{\circ}\text{C} < T_A < +125^{\circ}\text{C}$; $4.5\text{ V} < V_{\text{CC}} < 13.2\text{ V}$, $4.5\text{ V} < \text{BST-SWN} < 13.2\text{ V}$, $4.5\text{ V} < \text{BST} < 30\text{ V}$, $0\text{ V} < \text{SWN} < 21\text{ V}$)

Parameter	Test Conditions	Min.	Typ.	Max.	Units
SUPPLY VOLTAGE					
VCC Operation Voltage		4.5		13.2	V
Pre-OVP Threshold			2.75	3.2	V
UNDERVOLTAGE LOCKOUT					
VCC Start Threshold		3.8	4.35	4.5	V
VCC UVLO Hysteresis		150	200	250	mV
Output Overvoltage Trip Threshold at Startup	VCC > Pre-OVP Threshold NCP81166 NCP81166A	2.1 1.65	2.25 1.80	2.4 1.95	V
SUPPLY CURRENT					
Normal Mode	I _{cc} + I _{bst} , EN = 5 V, PWM = OSC, F _{sw} = 100 KHz, C _{load} = 3 nF for DRVH, 3 nF for DRVL		10		mA
Standby Current	I _{cc} + I _{bst} , EN = GND		0.5	1.4	mA
Standby Current	I _{CC} + I _{BST} , EN = HIGH, PWM = LOW, No loading on DRVH & DRVL		2.0		mA
Standby Current	I _{CC} + I _{BST} , EN = HIGH, PWM = HIGH, No loading on DRVH & DRVL		2.0		mA
BOOTSTRAP DIODE					
Forward Voltage	V _{CC} = 12 V, forward bias current = 2 mA	0.1	0.4	0.6	V
PWM INPUT					
PWM Input High		3.4			V
PWM Mid-State		1.3		2.7	V
PWM Input Low				0.7	V
ZCD Blanking Timer			250		ns
HIGH SIDE DRIVER (VCC = 12 V)					
Output Impedance, Sourcing Current	VBST – VSW = 12 V		1.9	3.0	Ω
Output Impedance, Sinking Current	VBST – VSW = 12 V		1.0	1.7	Ω
DRVH Rise Time t _{rDRVH}	V _{VCC} = 12 V, 3 nF load, VBST–VSW = 12 V		16	30	ns
DRVH Fall Time t _{fDRVH}	V _{VCC} = 12 V, 3 nF load, VBST–VSW = 12 V		11	25	ns
DRVH Turn-Off Propagation Delay t _{pdlDRVH}	C _{LOAD} = 3 nF	8.0		30	ns
DRVH Turn-On Propagation Delay t _{pdhDRVH}	C _{LOAD} = 3 nF			30	ns
SW Pull Down Resistance	SW to PGND		45		kΩ
DRVH Pull Down Resistance	DRVH to SW, BST–SW = 0 V		45		kΩ
HIGH SIDE DRIVER (VCC = 5 V)					
Output Impedance, Sourcing Current	VBST – VSW = 5 V		2.5		Ω
Output Impedance, Sinking Current	VBST – VSW = 5 V		1.6		Ω
DRVH Rise Time t _{rDRVH}	V _{VCC} = 5 V, 3 nF load, VBST – VSW = 5 V		30		ns
DRVH Fall Time t _{fDRVH}	V _{VCC} = 5 V, 3 nF load, VBST – VSW = 5 V		27		ns
DRVH Turn-Off Propagation Delay t _{pdlDRVH}	C _{LOAD} = 3 nF		20		ns
DRVH Turn-On Propagation Delay t _{pdhDRVH}	C _{LOAD} = 3 nF		27		ns
SW Pull Down Resistance	SW to PGND		45		kΩ

NCP81166, NCP81166A

Table 4. ELECTRICAL CHARACTERISTICS (Unless otherwise stated: $-10^{\circ}\text{C} < T_A < +125^{\circ}\text{C}$; $4.5\text{ V} < V_{CC} < 13.2\text{ V}$, $4.5\text{ V} < \text{BST-SWN} < 13.2\text{ V}$, $4.5\text{ V} < \text{BST} < 30\text{ V}$, $0\text{ V} < \text{SWN} < 21\text{ V}$)

Parameter	Test Conditions	Min.	Typ.	Max.	Units
-----------	-----------------	------	------	------	-------

HIGH SIDE DRIVER (VCC = 5 V)

DRVH Pull Down Resistance	DRVH to SW, BST-SW = 0 V		45		k Ω
---------------------------	--------------------------	--	----	--	------------

LOW SIDE DRIVER (VCC = 12 V)

Output Impedance, Sourcing Current			2.0	3.0	Ω
Output Impedance, Sinking Current			0.7	1.5	Ω
DRVL Rise Time t_{rDRVL}	$C_{LOAD} = 3\text{ nF}$		16	35	ns
DRVL Fall Time t_{fDRVL}	$C_{LOAD} = 3\text{ nF}$		11	20	ns
DRVL Turn-Off Propagation Delay t_{pdDRVL}	$C_{LOAD} = 3\text{ nF}$			35	ns
DRVL Turn-On Propagation Delay $t_{pdhDRVL}$	$C_{LOAD} = 3\text{ nF}$	8.0		30	ns
DRVL Pull Down Resistance	DRVL to PGND, VCC = PGND		45		k Ω

LOW SIDE DRIVER (VCC = 5 V)

Output Impedance, Sourcing Current			2.5		Ω
Output Impedance, Sinking Current			1.0		Ω
DRVL Rise Time t_{rDRVL}	$C_{LOAD} = 3\text{ nF}$		30		ns
DRVL Fall Time t_{fDRVL}	$C_{LOAD} = 3\text{ nF}$		22		ns
DRVL Turn-Off Propagation Delay t_{pdDRVL}	$C_{LOAD} = 3\text{ nF}$		27		ns
DRVL Turn-On Propagation Delay $t_{pdhDRVL}$	$C_{LOAD} = 3\text{ nF}$		12		ns
DRVL Pull Down Resistance	DRVL to PGND, VCC = PGND		45		k Ω

EN INPUT

Input Voltage High		2.0			V
Input Voltage Low				1.0	V
Hysteresis			500		mV
Normal Mode Bias Current		-1		1	μA
Enable Pin Sink Current		4		30	mA
Propagation Delay Time			20	40	ns

SW Node

SW Node Leakage Current				20	μA
Zero Cross Detection Threshold Voltage	SW to -20 mV, ramp slowly until BG goes off (Start in DCM mode) (Note 3)		-6		mV

Table 5. DECODER TRUTH TABLE

PWM INPUT	ZCD	DRVL	DRVH
PWM High	ZCD Reset	Low	High
PWM Mid	Positive current through the inductor	High	Low
PWM Mid	Zero current through the inductor	Low	Low
PWM Low	ZCD Reset	High	Low

3. Guaranteed by design; not production tested.

NCP81166, NCP81166A

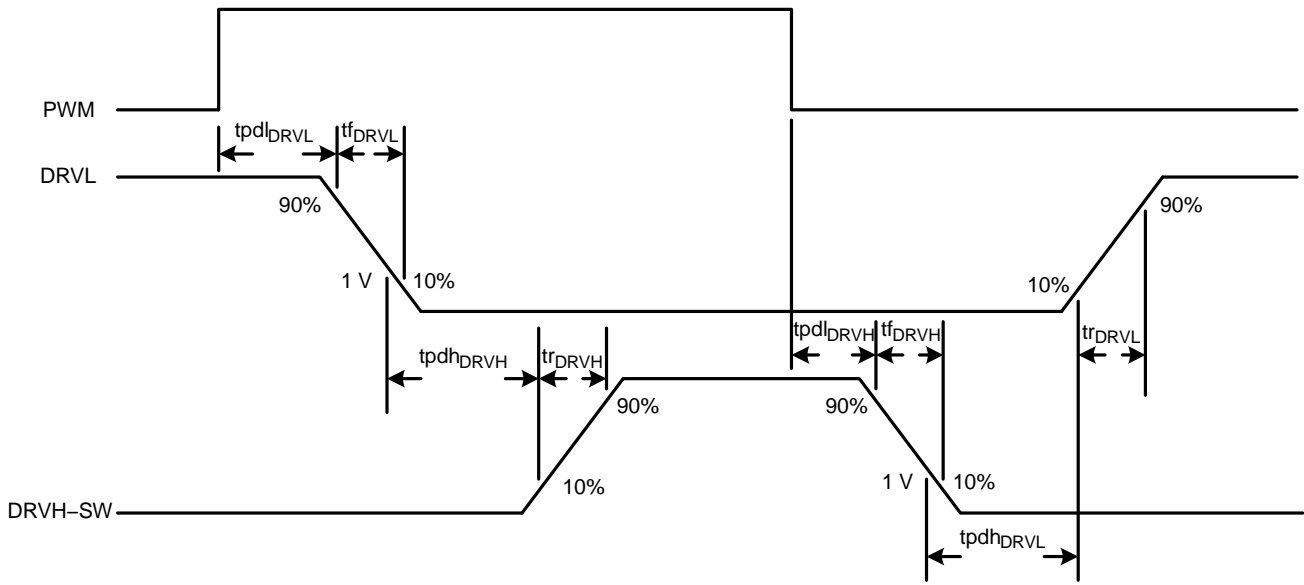

Figure 4. Timing Diagram

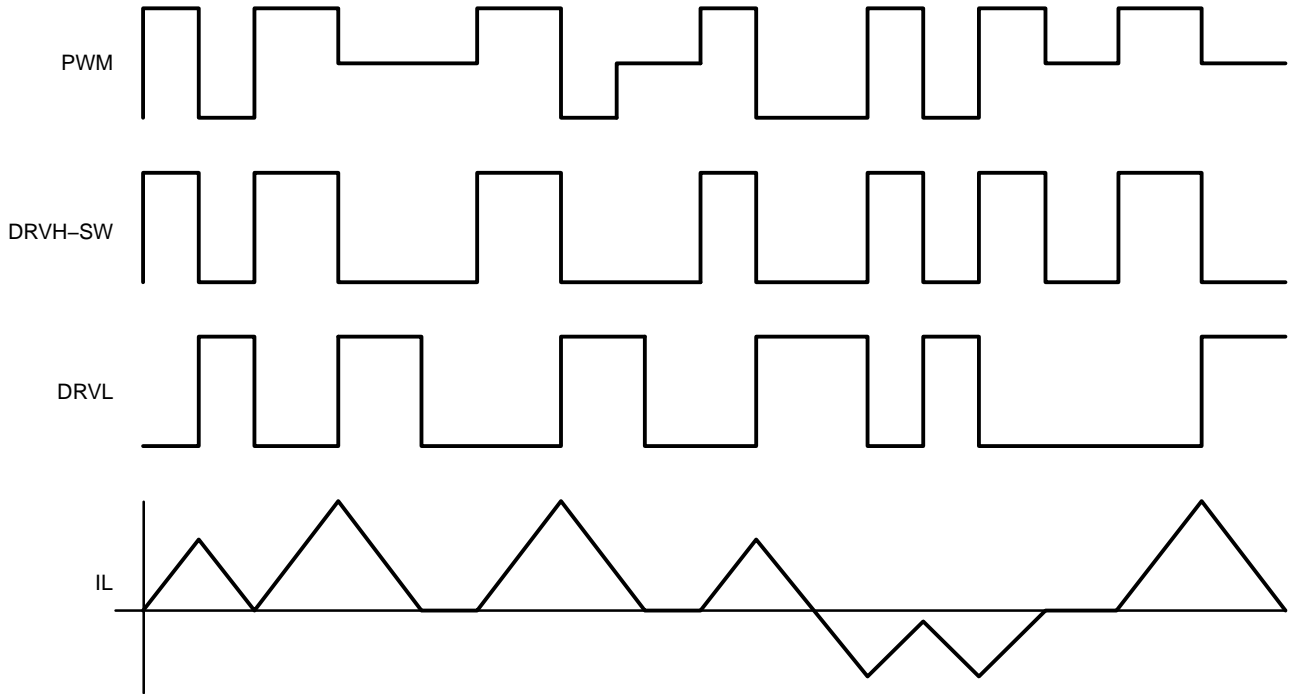

Figure 5. Logic Diagram

NCP81166, NCP81166A

APPLICATIONS INFORMATION

Description

The NCP81166/A gate driver is a single phase MOSFET driver designed for driving N-channel MOSFETs in a synchronous buck converter topology. The NCP81166 is designed to work with the ON Semiconductor's ASP1252 controller and the NCP81166A is designed to work with ON Semiconductor's ASP1400 controller.

Low-Side Driver

The low-side driver is designed to drive a ground-referenced low- $R_{DS(on)}$ N-channel MOSFET. The voltage supply for the low-side driver is internally connected to the VCC and GND pins. There is a 45 k Ω pull-down resistor connected between DRV_L and GND.

High-Side Driver

The high-side driver is designed to drive a floating low- $R_{DS(on)}$ N-channel MOSFET. The gate voltage for the high-side driver is developed by a bootstrap circuit referenced to the SW pin. There is a 45 k Ω pull-down resistor connected between DRV_H and SW.

The bootstrap circuit is comprised of the integrated diode and an external bootstrap capacitor. When the NCP81166/A is starting up, the SW pin is held at ground, allowing the bootstrap capacitor to charge up to VCC (minus the diode forward voltage) through the bootstrap diode. When the PWM input is driven high, the high-side driver will turn on the high-side MOSFET, using the stored charge of the bootstrap capacitor. As the high-side MOSFET turns on, the SW pin rises. When the high-side MOSFET is fully turned on, SW will settle to VIN and BST will settle to VIN + VCC (excluding parasitic ringing).

Bootstrap Circuit

The bootstrap circuit relies on an external charge storage capacitor (C_{BST}) and an integrated diode to provide current to the high-side driver. A multi-layer ceramic capacitor (MLCC) with a value greater than 100 nF should be used for C_{BST} .

Power Supply Decoupling

The NCP81166/A can source and sink relatively large currents to the gate pins of the MOSFETs. In order to maintain a constant and stable supply voltage, a low-ESR capacitor should be placed near the VCC and GND pins. A MLCC between 1 μ F and 4.7 μ F is typically used.

Undervoltage Lockout

DRV_H and DRV_L are low until VCC reaches the VCC UVLO threshold, typically 4.35 V. Once VCC reaches this threshold, the PWM signal will control DRV_H and DRV_L. There is a 200 mV hysteresis on VCC UVLO. There are pull-down resistors on DRV_H, DRV_L and SW to prevent the gates of the MOSFETs from accumulating enough charge to turn on when the driver is powered off.

Pre-Overvoltage Protection

The pre-Overvoltage Protection (pre-OVP) feature is used to protect the load if there is a short across the high-side FET. When VCC is greater than 2.75 V, the voltage on SW is monitored. During startup, if SW is determined to be greater than Output Overvoltage Trip Threshold, DRV_L will be latched high to turn on the synchronous FET and provide a path from VIN to ground. This also pulls the EN pin low. To exit this behavior, power to the driver must be turned off (VCC less than UVLO_RISING minus UVLO hysteresis) and then VCC powered back on. When VCC rises above UVLO_RISING and EN is above EN_HI, the gate driver enters normal PWM operation (DRV_H and DRV_L respond to the PWM signal) and the pre-OVP function is disabled.

Bi-Directional EN Signal

The Enable pin (EN) is used to disable the DRV_H and DRV_L outputs to prevent power transfer. When EN is above the EN_HI threshold, DRV_H and DRV_L change their states according to the PWM input. Fault modes, such as pre-OVP and UVLO, turn on an internal MOSFET that pulls the EN pin towards ground. By connecting EN to the DRON pin of a controller, the controller is alerted when the driver encounters a fault condition.

PWM Input and Zero Cross Detect (ZCD)

Switching PWM between logic-high and logic-low states will allow the driver to operate in continuous conduction mode as long as VCC is greater than the UVLO threshold and EN is high. The threshold limits are specified in the electrical characteristics table in this datasheet.

When PWM is set above PWM_HI, DRV_L will first turn off after a propagation delay of tpd_{DRV_L} . To ensure non-overlap between DRV_L and DRV_H, there is a delay of tpd_{DRV_H} from the time DRV_L falls to 1 V, before DRV_H is allowed to turn on.

When PWM falls below PWM_LO, DRV_H will first turn off after a propagation delay of tpd_{DRV_H} . To ensure non-overlap between DRV_H and DRV_L, there is a delay of tpd_{DRV_L} from the time DRV_H - SW falls to 1 V, before DRV_L is allowed to turn on.

When PWM enters the mid-state voltage range, PWM_MID, DRV_L goes high after the non-overlap delay, and stays high for the duration of the ZCD blanking timer and an 80 ns de-bounce timer. Once these timers expire, SW is monitored for zero current detection and pulls DRV_L low once zero current is detected.

Layout Guidelines

Layout for DC-DC converter is very important. The bootstrap and VCC bypass capacitors should be placed as close as to the driver IC as possible.

NCP81166, NCP81166A

Connect the GND flag to local ground plane. The ground plane can provide a good return path for gate drives and reduce the ground noise. This connection also allows for good heat dissipation. To minimize the ground loop for the

low-side MOSFET, the GND flag should be close to the low-side FET source pin. The gate drive trace should be routed to minimize the length, the minimum recommended width is 20 mils.

NCP81166, NCP81166A

PACKAGE DIMENSIONS

DFN8 2x2, 0.5P
CASE 506CN
ISSUE O

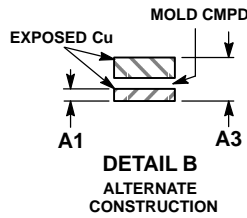
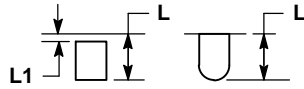
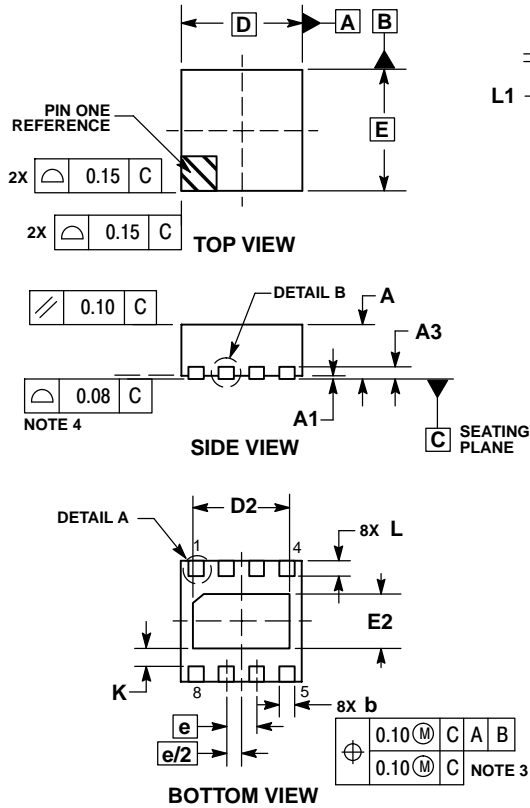

NOTES:

1. DIMENSIONING AND TOLERANCING PER ASME Y14.5M, 1994.
2. CONTROLLING DIMENSION: MILLIMETERS.
3. DIMENSION b APPLIES TO PLATED TERMINAL AND IS MEASURED BETWEEN 0.15 AND 0.30 MM FROM TERMINAL TIP.
4. COPLANARITY APPLIES TO THE EXPOSED PAD AS WELL AS THE TERMINALS.

MILLIMETERS		
DIM	MIN	MAX
A	0.80	1.00
A1	0.00	0.05
A3	0.20	REF
b	0.20	0.30
D	2.00	BSC
D2	1.50	1.70
E	2.00	BSC
E2	0.80	1.00
e	0.50	BSC
K	0.27	REF
L	0.17	0.38
L1	---	0.15

RECOMMENDED SOLDERING FOOTPRINT*

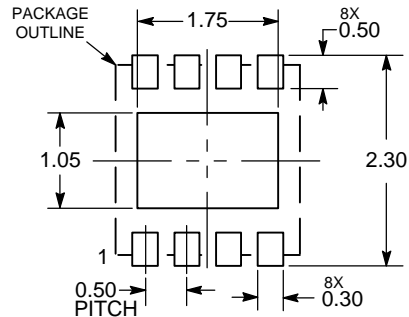

DIMENSIONS: MILLIMETERS

*For additional information on our Pb-Free strategy and soldering details, please download the ON Semiconductor Soldering and Mounting Techniques Reference Manual, SOLDERRM/D.

ON Semiconductor and are registered trademarks of Semiconductor Components Industries, LLC (SCILLC). SCILLC reserves the right to make changes without further notice to any products herein. SCILLC makes no warranty, representation or guarantee regarding the suitability of its products for any particular purpose, nor does SCILLC assume any liability arising out of the application or use of any product or circuit, and specifically disclaims any and all liability, including without limitation special, consequential or incidental damages. "Typical" parameters which may be provided in SCILLC data sheets and/or specifications can and do vary in different applications and actual performance may vary over time. All operating parameters, including "Typicals" must be validated for each customer application by customer's technical experts. SCILLC does not convey any license under its patent rights nor the rights of others. SCILLC products are not designed, intended, or authorized for use as components in systems intended for surgical implant into the body, or other applications intended to support or sustain life, or for any other application in which the failure of the SCILLC product could create a situation where personal injury or death may occur. Should Buyer purchase or use SCILLC products for any such unintended or unauthorized application, Buyer shall indemnify and hold SCILLC and its officers, employees, subsidiaries, affiliates, and distributors harmless against all claims, costs, damages, and expenses, and reasonable attorney fees arising out of, directly or indirectly, any claim of personal injury or death associated with such unintended or unauthorized use, even if such claim alleges that SCILLC was negligent regarding the design or manufacture of the part. SCILLC is an Equal Opportunity/Affirmative Action Employer. This literature is subject to all applicable copyright laws and is not for resale in any manner.

PUBLICATION ORDERING INFORMATION

LITERATURE FULFILLMENT:
Literature Distribution Center for ON Semiconductor
P.O. Box 5163, Denver, Colorado 80217 USA
Phone: 303-675-2175 or 800-344-3860 Toll Free USA/Canada
Fax: 303-675-2176 or 800-344-3867 Toll Free USA/Canada
Email: orderlit@onsemi.com

N. American Technical Support: 800-282-9855 Toll Free USA/Canada
Europe, Middle East and Africa Technical Support:
Phone: 421 33 790 2910
Japan Customer Focus Center
Phone: 81-3-5817-1050

ON Semiconductor Website: www.onsemi.com
Order Literature: <http://www.onsemi.com/orderlit>

For additional information, please contact your local Sales Representative