

# NB6L11

## 2.5 V/3.3 V Multilevel Input to Differential LVPECL/LVNECL 1:2 Clock or Data Fanout Buffer/Translator

The NB6L11 is an enhanced differential 1:2 clock or data fanout buffer/translator. The device has the same pinout and is functionally equivalent to the LVEL11, EP11, LVEP11 devices. Moreover, the device is optimized for the systems that require LOW skew, LOW jitter and LOW power consumption.

Differential input can be configured to accept single-ended signal by applying an external reference voltage to unused complementary input pin. Input accept LVNECL, LVPECL, LVTTTL, LVCMOS, CML, or LVDS. The outputs are 800 mV ECL signals.

### Features

- Maximum Input Clock Frequency  $\geq 6$  GHz Typical
- Maximum Input Data Rate  $\geq 6$  Gb/s Typical
- Low 14 mA Typical Power Supply Current
- 150 ps Typical Propagation Delay
- 5 ps Typical Within Device Skew
- 75 ps Typical Rise/Fall Times
- PECL Mode Operating Range:  
 $V_{CC} = 2.375$  V to  $3.465$  V with  $V_{EE} = 0$  V
- NECL Mode Op rating Range:  
 $V_{CC} = 0$  V with  $V_{EE} = -2.375$  V to  $-3.465$  V
- Open Input Default State
- Q Outputs Will Default LOW with Inputs Open or at  $V_{EE}$
- LVDS, LVPECL, LVNECL, LCMOS, LVTTTL and CML Input Compatible
- Pb-Free Packages are Available



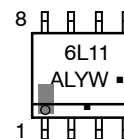
ON Semiconductor®

<http://onsemi.com>

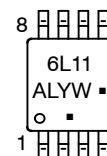
### MARKING DIAGRAMS\*



8  
1  
**SO-8**  
**D SUFFIX**  
**CASE 751**



8  
1  
**TSSOP-8**  
**DT SUFFIX**  
**CASE 948R**



A = Assembly Location  
L = Wafer Lot  
Y = Year  
W = Work Week  
▪ = Pb-Free Package

(Note: Microdot may be in either location)

\*For additional marking information, refer to Application Note AND8002/D.

### ORDERING INFORMATION

See detailed ordering and shipping information in the package dimensions section on page 10 of this data sheet.

# NB6L11

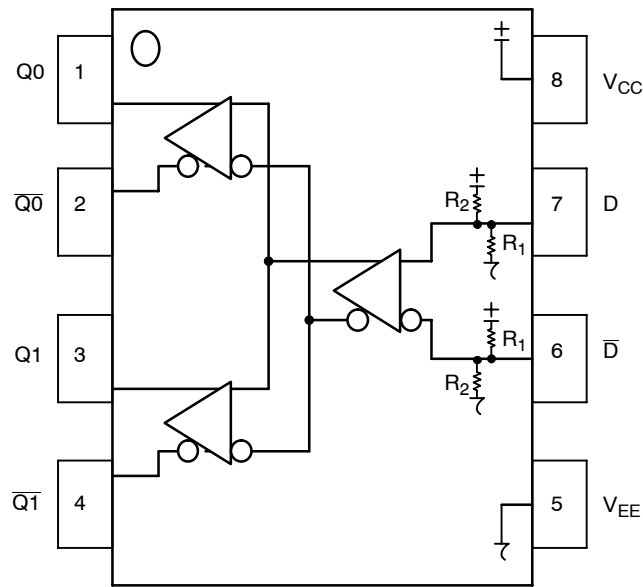


Figure 1. Pinout (Top View) and Logic Diagram

Table 1. PIN DESCRIPTION

Pin	Name	I/O	Default State	Description
1	Q0	ECL Output	-	Non-inverted differential clock/data output 0. Typically terminated with 50 $\Omega$ Resistor to $V_{TT} = V_{CC} - 2 V$ .
2	$\overline{Q0}$	ECL Output	-	Inverted differential clock/data output 0. Typically terminated with 50 $\Omega$ resistor to $V_{TT} = V_{CC} - 2 V$ .
3	Q1	ECL Output	-	Non-inverted differential clock/data output 1. Typically terminated with 50 $\Omega$ resistor to $V_{TT} = V_{CC} - 2 V$ .
4	$\overline{Q1}$	ECL Output	-	Inverted differential clock/data output 1. Typically terminated with 50 $\Omega$ resistor to $V_{TT} = V_{CC} - 2 V$ .
5	$V_{EE}$	-	-	Negative power supply voltage
6	$\overline{D}$	LVDS, CML, LVPECL, LVNECL, LVCMOS, LVTTTL Input	HIGH	Inverted differential clock/data input. Internal 37.5 k $\Omega$ to $V_{CC}$ and 75 k $\Omega$ to $V_{EE}$ .
7	D	LVDS, CML, LVPECL, LVNECL, LVCMOS, LVTTTL Input	LOW	Non-inverted differential clock/data input. Internal 75 k $\Omega$ to $V_{CC}$ and 37.5 k $\Omega$ to $V_{EE}$ .
8	$V_{CC}$	-	-	Positive power supply voltage

Table 2. ATTRIBUTES

Characteristics		Value	
Internal Input Pulldown Resistor		37.5 k $\Omega$	
Internal Input Pullup Resistor		75 k $\Omega$	
ESD Protection	Human Body Model	> 2 kV	
	Machine Model	> 100 V	
	Charged Device Model	> 1 kV	
Moisture Sensitivity, Indefinite Time Out of Drypack (Note 1)	Pb Pkg	Pb-Free Pkg	
	SOIC-8 TSSOP-8	Level 1 Level 1	Level 1 Level 3
Flammability Rating	Oxygen Index: 28 to 34	UL 94 V-0 @ 0.125 in	
Transistor Count	167 Devices		
Meets or exceeds JEDEC Spec EIA/JESD78 IC Latchup Test			

1. For additional information, see Application Note AND8003/D.

# NB6L11

**Table 3. MAXIMUM RATINGS**

Symbol	Parameter	Condition 1	Condition 2	Rating	Unit
$V_{CC}$	Positive Power Supply	$V_{EE} = 0\text{ V}$		3.6	V
$V_{EE}$	Negative Power Supply	$V_{CC} = 0\text{ V}$		-3.6	V
$V_I$	Positive Input Voltage Negative Input Voltage	$V_{EE} = 0\text{ V}$ $V_{CC} = 0\text{ V}$	$V_I \leq V_{CC}$ $V_I \geq V_{EE}$	3.6 -3.6	V V
$V_{INPP}$	Differential Input Voltage $ D - \bar{D} $	$V_{CC} - V_{EE} \geq 2.8\text{ V}$ $V_{CC} - V_{EE} < 2.8\text{ V}$		2.8 $ V_{CC} - V_{EE} $	V
$I_{out}$	Output Current	Continuous Surge		25 50	mA mA
$T_A$	Operating Temperature Range			-40 to +85	°C
$T_{stg}$	Storage Temperature Range			-65 to +150	°C
$\theta_{JA}$	Thermal Resistance (Junction-to-Ambient)	0 lfpm 500 lfpm	SOIC-8 SOIC-8	190 130	°C/W °C/W
$\theta_{JC}$	Thermal Resistance (Junction-to-Case)	Standard Board	SOIC-8	41 to 44	°C/W
$\theta_{JA}$	Thermal Resistance (Junction-to-Ambient)	0 lfpm 500 lfpm	TSSOP-8 TSSOP-8	185 140	°C/W °C/W
$\theta_{JC}$	Thermal Resistance (Junction-to-Case)	Standard Board	TSSOP-8	41 to 44	°C/W
$T_{sol}$	Wave Solder	Standard Pb-Free	$\leq 3\text{ sec @ }248^\circ\text{C}$ $\leq 3\text{ sec @ }260^\circ\text{C}$	265 265	°C

Stresses exceeding Maximum Ratings may damage the device. Maximum Ratings are stress ratings only. Functional operation above the Recommended Operating Conditions is not implied. Extended exposure to stresses above the Recommended Operating Conditions may affect device reliability.

# NB6L11

**Table 4. DC CHARACTERISTICS, PECL**  $V_{CC} = 2.5\text{ V}$ ,  $V_{EE} = 0\text{ V}$  (Note 4)

Symbol	Characteristic	-40°C			25°C			85°C			Unit
		Min	Typ	Max	Min	Typ	Max	Min	Typ	Max	
$I_{EE}$	Negative Power Supply Current (Note 5)	5	14	20	5	14	20	5	14	20	mA
$V_{OH}$	Output HIGH Voltage (Note 6)	1350	1450	1550	1400	1500	1600	1450	1550	1650	mV
$V_{OL}$	Output LOW Voltage (Note 6)	565	725	870	630	765	920	690	825	970	mV

**DIFFERENTIAL INPUT DRIVEN SINGLE-ENDED** (Figures 10, 12)

$V_{th}$	Input Threshold Reference Voltage Range (Note 2)	1125		$V_{CC} - 75$	1125		$V_{CC} - 75$	1125		$V_{CC} - 75$	mV
$V_{IH}$	Single-Ended Input HIGH Voltage	$V_{th} + 75$		$V_{CC}$	$V_{th} + 75$		$V_{CC}$	$V_{th} + 75$		$V_{CC}$	mV
$V_{IL}$	Single-Ended Input LOW Voltage	$V_{EE}$		$V_{th} - 75$	$V_{EE}$		$V_{th} - 75$	$V_{EE}$		$V_{th} - 75$	mV

**DIFFERENTIAL INPUTS DRIVEN DIFFERENTIALLY** (Figures 11, 13)

$V_{IHD}$	Differential Input HIGH Voltage	1200		$V_{CC}$	1200		$V_{CC}$	1200		$V_{CC}$	mV
$V_{ILD}$	Differential Input LOW Voltage	$V_{EE}$		$V_{CC} - 75$	$V_{EE}$		$V_{CC} - 75$	$V_{EE}$		$V_{CC} - 75$	mV
$V_{CMR}$	Input Common Mode Range (Differential Cross-Point Voltage) (Note 3)	1163		$V_{CC} - 38$	1163		$V_{CC} - 38$	1163		$V_{CC} - 38$	mV
$V_{ID}$	Differential Input Voltage ( $V_{IHD} - V_{ILD}$ )	75		2500	75		2500	75		2500	mV
$I_{IH}$	Input HIGH Current	$\frac{D}{\bar{D}}$	50 10	150 150	$\frac{D}{\bar{D}}$	50 10	150 150	$\frac{D}{\bar{D}}$	50 10	150 150	$\mu\text{A}$
$I_{IL}$	Input LOW Current	$\frac{D}{\bar{D}}$	-150 -150	-5 -30	$\frac{D}{\bar{D}}$	-150 -150	-5 -30	$\frac{D}{\bar{D}}$	-150 -150	-5 -30	$\mu\text{A}$

NOTE: Device will meet the specifications after thermal equilibrium has been established when mounted in a test socket or printed circuit board with maintained transverse airflow greater than 500 lfm. Electrical parameters are guaranteed only over the declared operating temperature range. Functional operation of the device exceeding these conditions is not implied. Device specification limit values are applied individually under normal operating conditions and not valid simultaneously.

2.  $V_{th}$  is applied to the complementary input when operating in single-ended mode.
3.  $V_{CMR}$  minimum varies 1:1 with  $V_{EE}$ ,  $V_{CMR}$  maximum varies 1:1 with  $V_{CC}$ .
4. Input and output parameters vary 1:1 with  $V_{CC}$ .  $V_{EE}$  can vary +0.125 V to -1.3 V.
5. All input and output pins left open.
6. All loading with 50  $\Omega$  to  $V_{CC} - 2.0\text{ V}$ .

# NB6L11

**Table 5. DC CHARACTERISTICS, PECL**  $V_{CC} = 3.3\text{ V}$ ,  $V_{EE} = 0\text{ V}$  (Note 9)

Symbol	Characteristic	-40°C			25°C			85°C			Unit
		Min	Typ	Max	Min	Typ	Max	Min	Typ	Max	
$I_{EE}$	Negative Power Supply Current (Note 10)	5	14	20	5	14	20	5	14	20	mA
$V_{OH}$	Output HIGH Voltage (Note 11)	2150	2250	2350	2200	2300	2400	2250	2350	2450	mV
$V_{OL}$	Output LOW Voltage (Note 11)	1365	1525	1670	1430	1565	1720	1490	1625	1770	mV

**DIFFERENTIAL INPUT DRIVEN SINGLE-ENDED** (Figures 10, 12)

$V_{th}$	Input Threshold Reference Voltage Range (Note 7)	1125		$V_{CC} - 75$	1125		$V_{CC} - 75$	1125		$V_{CC} - 75$	mV
$V_{IH}$	Single-Ended Input HIGH Voltage	$V_{th} + 75$		$V_{CC}$	$V_{th} + 75$		$V_{CC}$	$V_{th} + 75$		$V_{CC}$	mV
$V_{IL}$	Single-Ended Input LOW Voltage	$V_{EE}$		$V_{th} - 75$	$V_{EE}$		$V_{th} - 75$	$V_{EE}$		$V_{th} - 75$	mV

**DIFFERENTIAL INPUTS DRIVEN DIFFERENTIALLY** (Figures 11, 13)

$V_{IHD}$	Differential Input HIGH Voltage	1200		$V_{CC}$	1200		$V_{CC}$	1200		$V_{CC}$	mV
$V_{ILD}$	Differential Input LOW Voltage	$V_{EE}$		$V_{CC} - 75$	$V_{EE}$		$V_{CC} - 75$	$V_{EE}$		$V_{CC} - 75$	mV
$V_{CMR}$	Input Common Mode Range (Differential Cross-Point Voltage) (Note 8)	1163		$V_{CC} - 38$	1163		$V_{CC} - 38$	1163		$V_{CC} - 38$	mV
$V_{ID}$	Differential Input Voltage ( $V_{IHD} - V_{ILD}$ )	75		2500	75		2500	75		2500	mV
$I_{IH}$	Input HIGH Current	$\overline{D}$	50	150		50	150		50	150	$\mu\text{A}$
		$D$	10	150		10	150		10	150	
$I_{IL}$	Input LOW Current	$\overline{D}$	-150	-5		-150	-5		-150	-5	$\mu\text{A}$
		$D$	-150	-30		-150	-30		-150	-30	

NOTE: Device will meet the specifications after thermal equilibrium has been established when mounted in a test socket or printed circuit board with maintained transverse airflow greater than 500 lfm. Electrical parameters are guaranteed only over the declared operating temperature range. Functional operation of the device exceeding these conditions is not implied. Device specification limit values are applied individually under normal operating conditions and not valid simultaneously.

7.  $V_{th}$  is applied to the complementary input when operating in single-ended mode.
8.  $V_{CMR}$  minimum varies 1:1 with  $V_{EE}$ ,  $V_{CMR}$  maximum varies 1:1 with  $V_{CC}$ .
9. Input and output parameters vary 1:1 with  $V_{CC}$ .  $V_{EE}$  can vary +0.3 V to -2.2 V.
10. All input and output pins left open.
11. All loading with 50  $\Omega$  to  $V_{CC} - 2.0\text{ V}$ .

# NB6L11

**Table 6. DC CHARACTERISTICS, NECL**  $V_{CC} = 0\text{ V}$ ;  $V_{EE} = -3.465\text{ V}$  to  $-2.375\text{ V}$  (Note 14)

Symbol	Characteristic	-40°C			25°C			85°C			Unit
		Min	Typ	Max	Min	Typ	Max	Min	Typ	Max	
$I_{EE}$	Negative Power Supply Current (Note 15)	5	14	20	5	14	20	5	14	20	mA
$V_{OH}$	Output HIGH Voltage (Note 16)	-1150	-1050	-950	-1100	-1000	-900	-1050	-950	-850	mV
$V_{OL}$	Output LOW Voltage (Note 16)	-1935	-1775	-1630	-1870	-1735	-1580	-1810	-1675	-1530	mV

**DIFFERENTIAL INPUT DRIVEN SINGLE-ENDED** (Figures 10, 12)

$V_{th}$	Input Threshold Reference Voltage Range (Note 12)	$V_{EE} + 1125$		$V_{CC} - 75$	$V_{EE} + 1125$		$V_{CC} - 75$	$V_{EE} + 1125$		$V_{CC} - 75$	mV
$V_{IH}$	Single-Ended Input HIGH Voltage	$V_{th} + 75$		$V_{CC}$	$V_{th} + 75$		$V_{CC}$	$V_{th} + 75$		$V_{CC}$	mV
$V_{IL}$	Single-Ended Input LOW Voltage	$V_{EE}$		$V_{th} - 75$	$V_{EE}$		$V_{th} - 75$	$V_{EE}$		$V_{th} - 75$	mV

**DIFFERENTIAL INPUTS DRIVEN DIFFERENTIALLY** (Figures 11, 13)

$V_{IHD}$	Differential Input HIGH Voltage	$V_{EE} + 1200$		$V_{CC}$	$V_{EE} + 1200$		$V_{CC}$	$V_{EE} + 1200$		$V_{CC}$	mV
$V_{ILD}$	Differential Input LOW Voltage	$V_{EE}$		$V_{CC} - 75$	$V_{EE}$		$V_{CC} - 75$	$V_{EE}$		$V_{CC} - 75$	mV
$V_{CMR}$	Input Common Mode Range (Differential Cross-Point Voltage) (Note 13)	$V_{EE} + 1163$		$V_{CC} - 38$	$V_{EE} + 1163$		$V_{CC} - 38$	$V_{EE} + 1163$		$V_{CC} - 38$	mV
$V_{ID}$	Differential Input Voltage ( $V_{IHD} - V_{ILD}$ )	75		2500	75		2500	75		2500	mV
$I_{IH}$	Input HIGH Current	$\overline{D}$	50	150	$\overline{D}$	50	150	$\overline{D}$	50	150	$\mu\text{A}$
$I_{IL}$	Input LOW Current	$\overline{D}$	-150	-5	$\overline{D}$	-150	-5	$\overline{D}$	-150	-5	$\mu\text{A}$

NOTE: Device will meet the specifications after thermal equilibrium has been established when mounted in a test socket or printed circuit board with maintained transverse airflow greater than 500 lfpm. Electrical parameters are guaranteed only over the declared operating temperature range. Functional operation of the device exceeding these conditions is not implied. Device specification limit values are applied individually under normal operating conditions and not valid simultaneously.

12.  $V_{th}$  is applied to the complementary input when operating in single-ended mode.

13.  $V_{CMR}$  minimum varies 1:1 with  $V_{EE}$ ,  $V_{CMR}$  maximum varies 1:1 with  $V_{CC}$

14. Input and output parameters vary 1:1 with  $V_{CC}$ .

15. Input and output pins left open.

16. All loading with  $50\ \Omega$  to  $V_{CC} - 2.0\text{ V}$ .

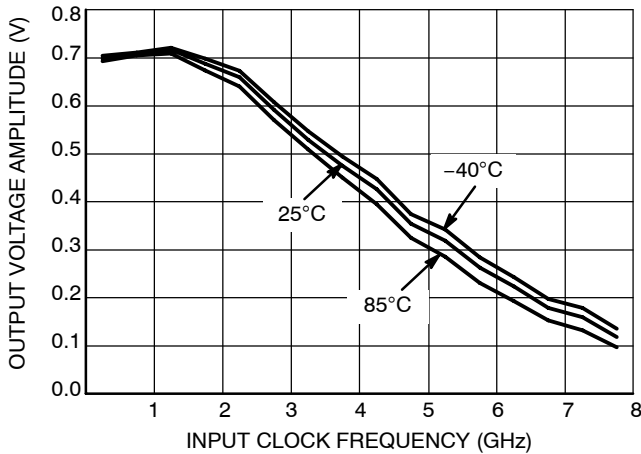
# NB6L11

**Table 7. AC CHARACTERISTICS**  $V_{CC} = 0\text{ V}$ ;  $V_{EE} = -3.465\text{ V}$  to  $-2.375\text{ V}$  or  $V_{CC} = 2.375\text{ V}$  to  $3.465\text{ V}$ ;  $V_{EE} = 0\text{ V}$  (Note 17)

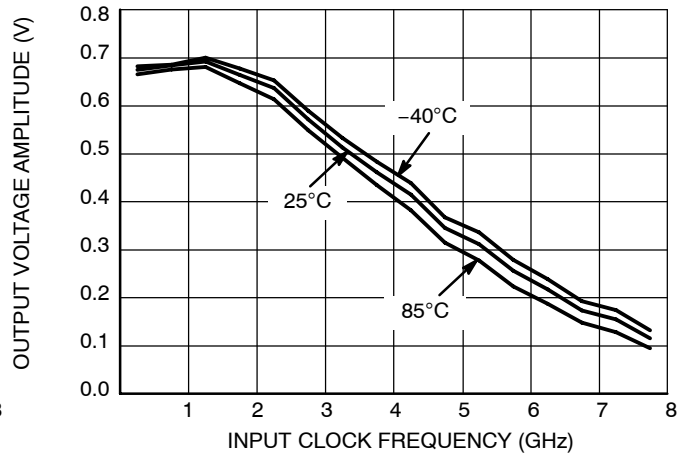
Symbol	Characteristic	-40°C			25°C			85°C			Unit
		Min	Typ	Max	Min	Typ	Max	Min	Typ	Max	
$V_{OUTPP}$	Output Voltage Amplitude (See Figures 2 & 3) $f_{in} \leq 3\text{ GHz}$ $f_{in} \leq 6\text{ GHz}$	480 270	700 300		480 270	700 300		480 270	700 300		mV
$t_{PLH}$ , $t_{PHL}$	Propagation Delay to Output Differential @ 1 GHz D to Q, $\bar{Q}$	110	150	190	110	150	200	120	160	220	ps
$t_{SKEW}$	Duty Cycle Skew Within Device Skew Device-to-Device Skew (Note 18)		2 5 15	10 15 60		2 5 15	10 15 60		2 5 15	10 15 60	ps
$t_{JITTER}$	RMS Random Clock Jitter (Note 19) Peak-to-Peak Data Dependent Jitter (Note 20) $f_{in} \leq 6\text{ GHz}$ $f_{in} \leq 6\text{ Gb/s}$		0.2 2	1 12		0.2 2	1 12		0.2 2	1 12	ps
$V_{INPP}$	Input Voltage Swing / Sensitivity (Differential Configuration) (Note 21)	75	700	2500	75	700	2500	75	700	2500	mV
$t_r$ , $t_f$	Output Rise/Fall Times @ 1 GHz (20% - 80%) Q, $\bar{Q}$	30	75	120	30	75	120	30	75	120	ps

NOTE: Device will meet the specifications after thermal equilibrium has been established when mounted in a test socket or printed circuit board with maintained transverse airflow greater than 500 lfm. Electrical parameters are guaranteed only over the declared operating temperature range. Functional operation of the device exceeding these conditions is not implied. Device specification limit values are applied individually under normal operating conditions and not valid simultaneously.

17. Measured using a 800 mV source, 50% duty cycle clock source. All loading with  $50\ \Omega$  to  $V_{CC} - 2.0\text{ V}$ . Input edge rates 40 ps (20% - 80%).
18. See Figure 9  $t_{skew} = |t_{PLH} - t_{PHL}|$  for a nominal 50% differential clock input waveform. Skew is measured between outputs under identical transitions and conditions @ 1 GHz.
19. Additive RMS jitter with 50% duty cycle clock signal at 6 GHz.
20. Additive Peak-to-Peak data dependent jitter with NRZ PRBS  $2^{23}-1$  data rate at 6 Gb/s.
21.  $V_{INPP(max)}$  cannot exceed  $V_{CC} - V_{EE}$  (applicable only when  $V_{CC} - V_{EE} < 2500\text{ mV}$ ). Input voltage swing is a single-ended measurement operating in differential mode

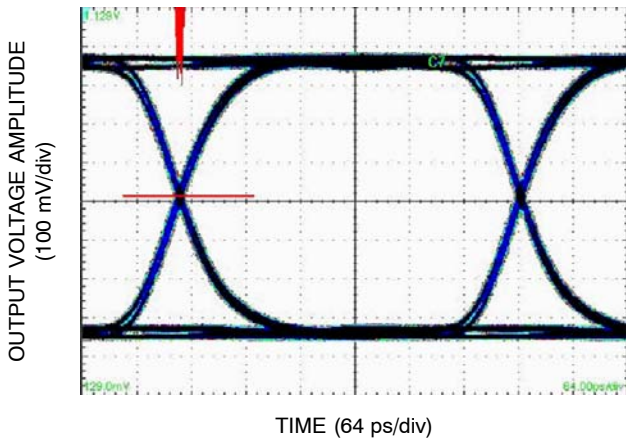


**Figure 2. Output Voltage Amplitude ( $V_{OUTPP}$ ) versus Input Clock Frequency ( $f_{IN}$ ) and Temperature at  $V_{CC} - V_{EE} = 3.3\text{ V}$**

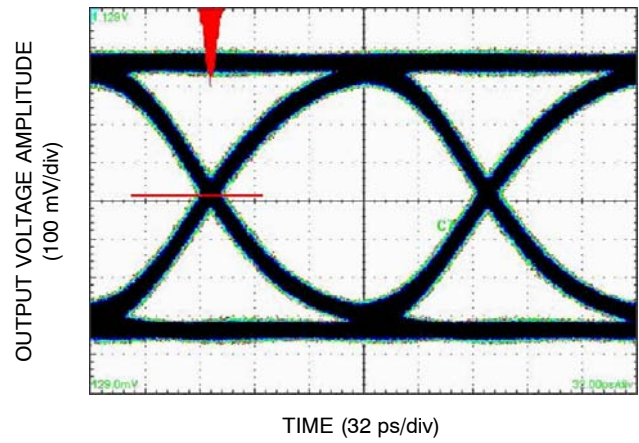


**Figure 3. Output Voltage Amplitude ( $V_{OUTPP}$ ) versus Input Clock Frequency ( $f_{IN}$ ) and Temperature at  $V_{CC} - V_{EE} = 2.5\text{ V}$**

# NB6L11

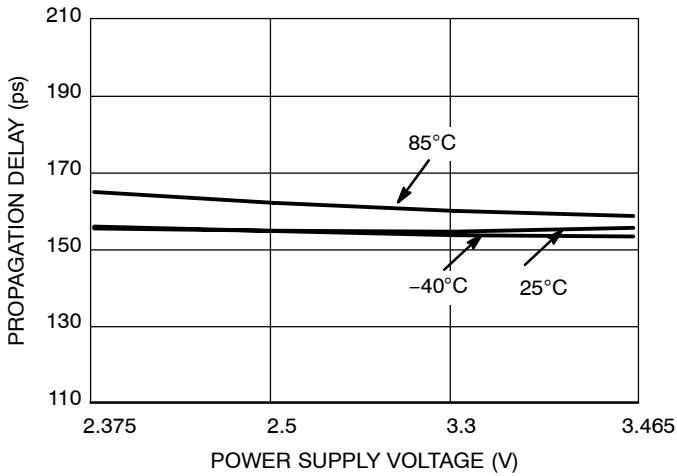


**Figure 4. Typical Output Waveform at 2.488 Gb/s with PRBS 2<sup>23</sup>-1 (Total System Pk-Pk Jitter is 17 ps. Device Pk-Pk Jitter Contribution is 4 ps)**

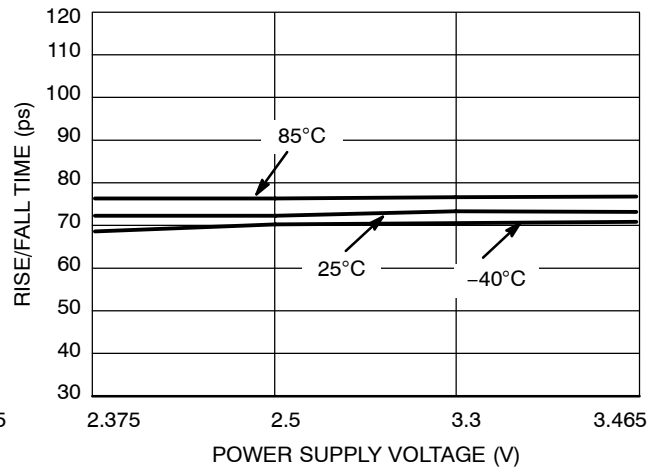


**Figure 5. Typical Output Waveform at 6.125 Gb/s with PRBS 2<sup>23</sup>-1 (Total System Pk-Pk Jitter is 20 ps. Device Pk-Pk Jitter Contribution is 5 ps)**

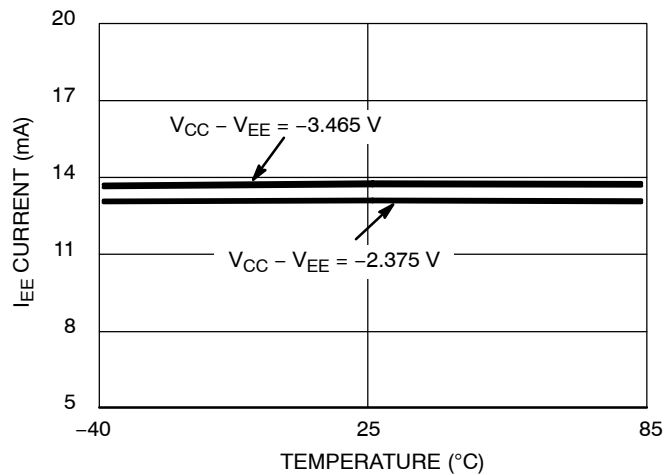
NOTE:  $V_{CC} - V_{EE} = 3.3 \text{ V}$ ;  $V_{IN} = 700 \text{ mV}$ ;  $T_A = 25^\circ\text{C}$ .



**Figure 6. Propagation Delay versus Power Supply Voltage and Temperature**



**Figure 7. Rise/Fall Time versus Power Supply Voltage and Temperature**



**Figure 8.  $I_{EE}$  Current versus Temperature and Power Supply Voltage**



# NB6L11

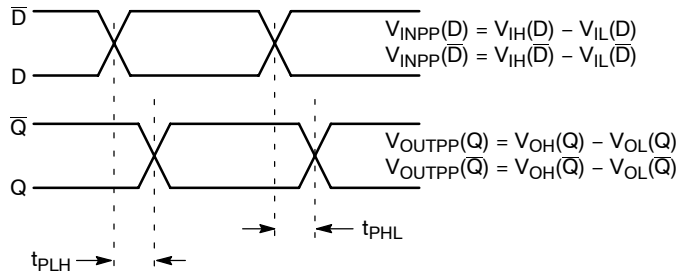


Figure 9. AC Reference Measurement

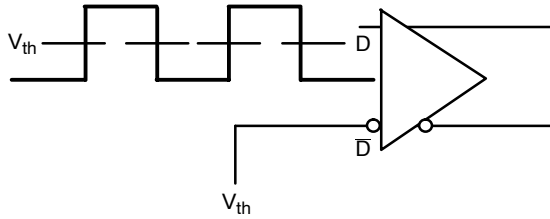


Figure 10. Differential Input Driven Single-Ended

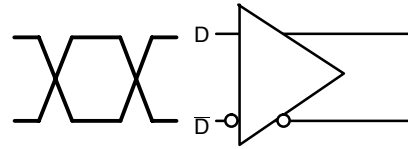


Figure 11. Differential Inputs Driven Differentially

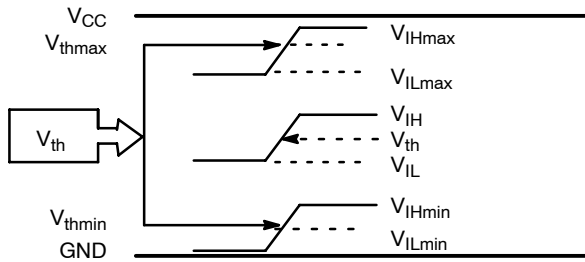


Figure 12.  $V_{th}$  Diagram

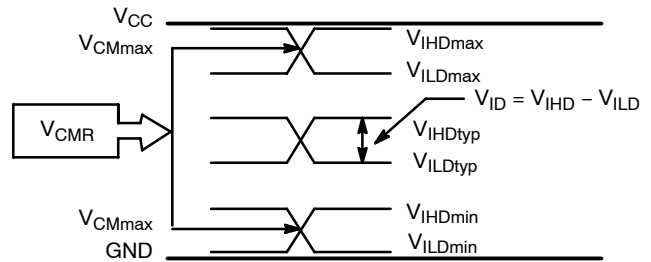


Figure 13.  $V_{CMR}$  Diagram

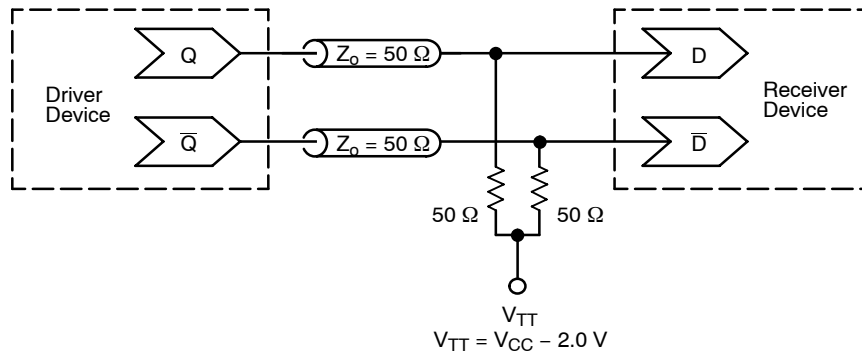


Figure 14. Typical Termination for Output Driver and Device Evaluation (See Application Note AND8020/D – Termination of ECL Logic Devices.)

# NB6L11

## ORDERING INFORMATION

Device	Package	Shipping <sup>†</sup>
NB6L11D	SOIC-8	98 Units / Rail
NB6L11DG	SOIC-8 (Pb-Free)	98 Units / Rail
NB6L11DR2	SOIC-8	2500 / Tape & Reel
NB6L11DR2G	SOIC-8 (Pb-Free)	2500 / Tape & Reel
NB6L11DT	TSSOP-8	100 Units / Rail
NB6L11DTG*	TSSOP-8 (Pb-Free)	100 Units / Rail
NB6L11DTR2	TSSOP-8	2500 / Tape & Reel
NB6L11DTR2G*	TSSOP-8 (Pb-Free)	2500 / Tape & Reel

<sup>†</sup>For information on tape and reel specifications, including part orientation and tape sizes, please refer to our Tape and Reel Packaging Specifications Brochure, BRD8011/D.

\*Future Product – Contact factory for availability.

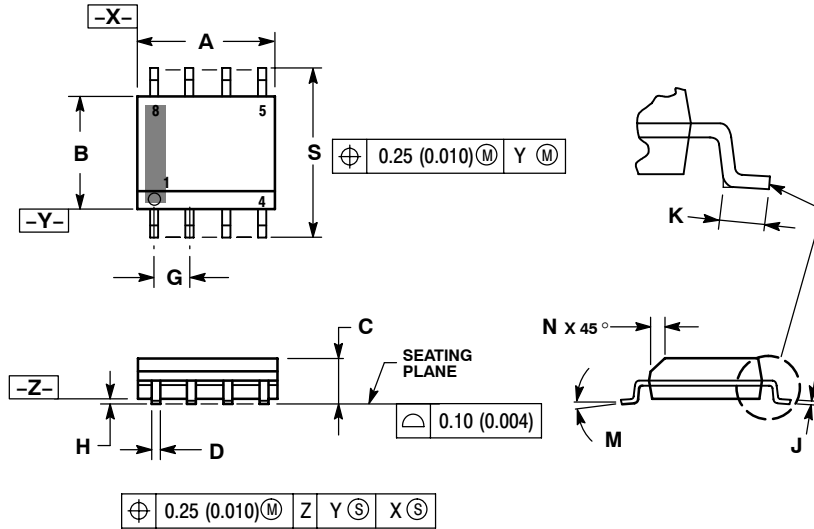
### Resource Reference of Application Notes

- AN1405/D** – ECL Clock Distribution Techniques
- AN1406/D** – Designing with PECL (ECL at +5.0 V)
- AN1503/D** – ECLinPS™ I/O SPiCE Modeling Kit
- AN1504/D** – Metastability and the ECLinPS Family
- AN1568/D** – Interfacing Between LVDS and ECL
- AN1672/D** – The ECL Translator Guide
- AND8001/D** – Odd Number Counters Design
- AND8002/D** – Marking and Date Codes
- AND8020/D** – Termination of ECL Logic Devices
- AND8066/D** – Interfacing with ECLinPS
- AND8090/D** – AC Characteristics of ECL Devices

# NB6L11

## PACKAGE DIMENSIONS

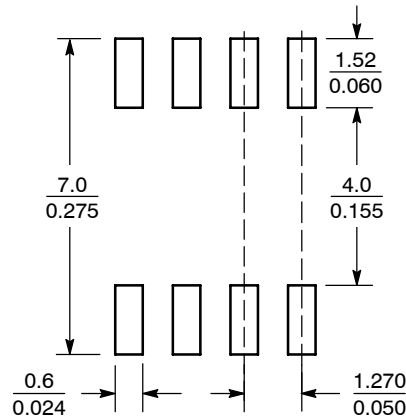
SOIC-8 NB  
CASE 751-07  
ISSUE AH



- NOTES:
1. DIMENSIONING AND TOLERANCING PER ANSI Y14.5M, 1982.
  2. CONTROLLING DIMENSION: MILLIMETER.
  3. DIMENSION A AND B DO NOT INCLUDE MOLD PROTRUSION.
  4. MAXIMUM MOLD PROTRUSION 0.15 (0.006) PER SIDE.
  5. DIMENSION D DOES NOT INCLUDE DAMBAR PROTRUSION. ALLOWABLE DAMBAR PROTRUSION SHALL BE 0.127 (0.005) TOTAL IN EXCESS OF THE D DIMENSION AT MAXIMUM MATERIAL CONDITION.
  6. 751-01 THRU 751-06 ARE OBSOLETE. NEW STANDARD IS 751-07.

DIM	MILLIMETERS		INCHES	
	MIN	MAX	MIN	MAX
A	4.80	5.00	0.189	0.197
B	3.80	4.00	0.150	0.157
C	1.35	1.75	0.053	0.069
D	0.33	0.51	0.013	0.020
G	1.27 BSC		0.050 BSC	
H	0.10	0.25	0.004	0.010
J	0.19	0.25	0.007	0.010
K	0.40	1.27	0.016	0.050
M	0°	8°	0°	8°
N	0.25	0.50	0.010	0.020
S	5.80	6.20	0.228	0.244

### SOLDERING FOOTPRINT\*



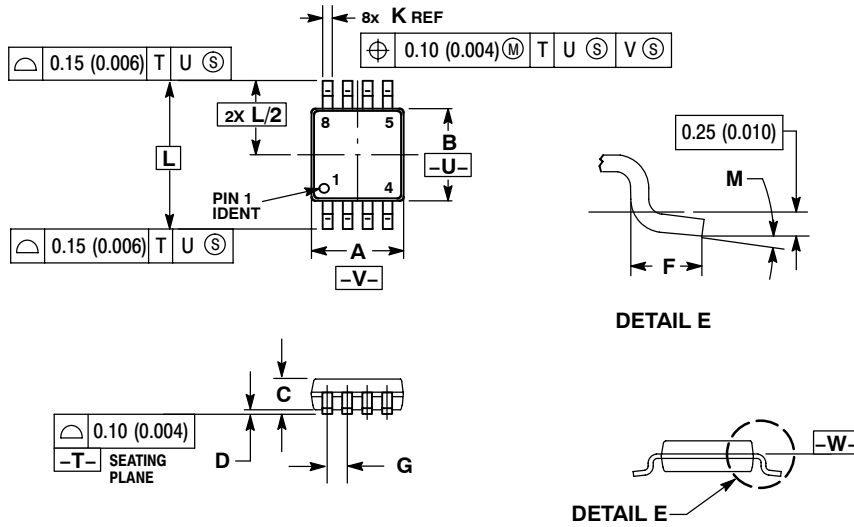
SCALE 6:1  $\left(\frac{\text{mm}}{\text{inches}}\right)$

\*For additional information on our Pb-Free strategy and soldering details, please download the ON Semiconductor Soldering and Mounting Techniques Reference Manual, SOLDERRM/D.

# NB6L11

## PACKAGE DIMENSIONS

### TSSOP-8 DT SUFFIX PLASTIC TSSOP PACKAGE CASE 948R-02 ISSUE A



#### NOTES:

1. DIMENSIONING AND TOLERANCING PER ANSI Y14.5M, 1982.
2. CONTROLLING DIMENSION: MILLIMETER.
3. DIMENSION A DOES NOT INCLUDE MOLD FLASH, PROTRUSIONS OR GATE BURRS. MOLD FLASH OR GATE BURRS SHALL NOT EXCEED 0.15 (0.006) PER SIDE.
4. DIMENSION B DOES NOT INCLUDE INTERLEAD FLASH OR PROTRUSION. INTERLEAD FLASH OR PROTRUSION SHALL NOT EXCEED 0.25 (0.010) PER SIDE.
5. TERMINAL NUMBERS ARE SHOWN FOR REFERENCE ONLY.
6. DIMENSION A AND B ARE TO BE DETERMINED AT DATUM PLANE -W-.

DIM	MILLIMETERS		INCHES	
	MIN	MAX	MIN	MAX
A	2.90	3.10	0.114	0.122
B	2.90	3.10	0.114	0.122
C	0.80	1.10	0.031	0.043
D	0.05	0.15	0.002	0.006
F	0.40	0.70	0.016	0.028
G	0.65 BSC		0.026 BSC	
K	0.25	0.40	0.010	0.016
L	4.90 BSC		0.193 BSC	
M	0°	6°	0°	6°

ECLinPS is a trademark of Semiconductor Components Industries, LLC.

**ON Semiconductor** and **ON** are registered trademarks of Semiconductor Components Industries, LLC (SCILLC). SCILLC reserves the right to make changes without further notice to any products herein. SCILLC makes no warranty, representation or guarantee regarding the suitability of its products for any particular purpose, nor does SCILLC assume any liability arising out of the application or use of any product or circuit, and specifically disclaims any and all liability, including without limitation special, consequential or incidental damages. "Typical" parameters which may be provided in SCILLC data sheets and/or specifications can and do vary in different applications and actual performance may vary over time. All operating parameters, including "Typicals" must be validated for each customer application by customer's technical experts. SCILLC does not convey any license under its patent rights nor the rights of others. SCILLC products are not designed, intended, or authorized for use as components in systems intended for surgical implant into the body, or other applications intended to support or sustain life, or for any other application in which the failure of the SCILLC product could create a situation where personal injury or death may occur. Should Buyer purchase or use SCILLC products for any such unintended or unauthorized application, Buyer shall indemnify and hold SCILLC and its officers, employees, subsidiaries, affiliates, and distributors harmless against all claims, costs, damages, and expenses, and reasonable attorney fees arising out of, directly or indirectly, any claim of personal injury or death associated with such unintended or unauthorized use, even if such claim alleges that SCILLC was negligent regarding the design or manufacture of the part. SCILLC is an Equal Opportunity/Affirmative Action Employer. This literature is subject to all applicable copyright laws and is not for resale in any manner.

#### PUBLICATION ORDERING INFORMATION

**LITERATURE FULFILLMENT:**  
Literature Distribution Center for ON Semiconductor  
P.O. Box 5163, Denver, Colorado 80217 USA  
**Phone:** 303-675-2175 or 800-344-3860 Toll Free USA/Canada  
**Fax:** 303-675-2176 or 800-344-3867 Toll Free USA/Canada  
**Email:** orderlit@onsemi.com

**N. American Technical Support:** 800-282-9855 Toll Free  
USA/Canada  
**Europe, Middle East and Africa Technical Support:**  
Phone: 421 33 790 2910  
**Japan Customer Focus Center**  
Phone: 81-3-5773-3850

**ON Semiconductor Website:** [www.onsemi.com](http://www.onsemi.com)  
**Order Literature:** <http://www.onsemi.com/orderlit>

For additional information, please contact your local Sales Representative