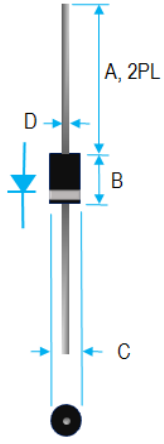

## 4A ULTRA FAST RECTIFIER

 <table border="1" data-bbox="373 420 706 609"> <thead> <tr> <th rowspan="2">Dim.</th> <th colspan="2">Value Inch[mm]</th> </tr> <tr> <th>Min.</th> <th>Max.</th> </tr> </thead> <tbody> <tr> <td>A</td> <td>1.000[25.40]</td> <td>---</td> </tr> <tr> <td>B</td> <td>0.335[8.51]</td> <td>0.375[9.52]</td> </tr> <tr> <td>C</td> <td>0.197[5.00]</td> <td>0.220[5.59]</td> </tr> <tr> <td>D</td> <td>0.048[1.22]</td> <td>0.052[1.32]</td> </tr> </tbody> </table>	Dim.	Value Inch[mm]		Min.	Max.	A	1.000[25.40]	---	B	0.335[8.51]	0.375[9.52]	C	0.197[5.00]	0.220[5.59]	D	0.048[1.22]	0.052[1.32]	<h3>PRODUCT FEATURES</h3> <ol style="list-style-type: none"> <li>1. FLAMMABILITY CLASSIFICATION: 94V-0</li> <li>2. GLASS PASSIVATED CHIP JUNCTION</li> <li>3. LOW LEAKAGE</li> <li>4. LOW FORWARD VOLTAGE DROP</li> <li>5. HIGH SURGE CURRENT CAPABILITY</li> <li>6. ULTRA FAST SWITCHING</li> <li>7. LOW LOSSES</li> <li>8. CASE: MOLDED PLASTIC, DO-201AD</li> <li>9. POLARITY: INDICATED BY CATHODE BAND</li> <li>10. WEIGHT: 1.2 GRAMS</li> <li>11. LEADS: SOLDERABILITY PER MIL-STD-202 METHOD 208</li> <li>12. RoHS</li> </ol>
Dim.		Value Inch[mm]																
	Min.	Max.																
A	1.000[25.40]	---																
B	0.335[8.51]	0.375[9.52]																
C	0.197[5.00]	0.220[5.59]																
D	0.048[1.22]	0.052[1.32]																

MAXIMUM RATINGS AND ELECTRICAL CHARACTERISTICS RATINGS AT 25°C AMBIENT TEMPERATURE UNLESS OTHERWISE SPECIFIED STORAGE AND OPERATING TEMPERATURE RANGE -55°C TO +150°C. SINGLE PHASE, HALF WAVE, 60 HZ, RESISTIVE OR INDUCTIVE LOAD. FOR CAPACITIVE LOAD, DERATE CURRENT BY 20%.

RATINGS	SYMBOL	VALUE	UNITS
MAXIMUM AVERAGE FORWARD RECTIFIED CURRENT 0.375"(9.5mm) LEAD LENGTH @ TA=55°C	$I_o$	4.0	A
TYPICAL JUNCTION CAPACITANCE(NOTE 1)	$C_j$	70	pF
TYPICAL THERMAL RESISTANCE (NOTE 2)	$R_{\theta ja}$	50	°C/W
MAXIMUM REVERSE CURRENT @ 25°C	$I_R$	10	uA
MAXIMUM REVERSE CURRENT @ 100°C	$I_R$	100	uA

1.  $C_j$  MEASURED @ 1 MHZ AND APPLIED REVERSE VOLTAGE OF 4.0 VOLTS
2. BOTH LEADS ATTACHED TO HEAT SINK 20x20x1 T (mm) COPPER PLATE @ LEAD LENGTH 5mm
3. REVERSE RECOVERY TEST CONDITIONS:  $I_F=0.5A$ ,  $I_R=1.0A$ ,  $I_{RR}=0.25A$
4. MAXIMUM FORWARD VOLTAGE @  $I_o$  DC

PART NUMBER	MAX RECURRENT PEAK REV VOLTAGE $V_{RRM}$ (V)	MAX RMS VOLTAGE $V_{RMS}$ (V)	MAX DC BLOCKING VOLTAGE $V_{DC}$ (V)	MAX FWD VOLTAGE $V_F$ (V)	MAX REVERSE RECOVERY TIME $T_{RR}$ (nS)
MUR405	50	35	50	0.92	50
MUR410	100	70	100	0.92	50
MUR415	150	105	150	0.92	50
MUR420	200	140	200	0.92	50
MUR440	400	280	400	1.25	50
MUR460	600	480	600	1.25	50
MUR480	800	560	800	1.85	75
MUR4100	1000	700	1000	1.85	75

## RATING AND CHARACTERISTIC CURVES

FIG. 1-TEST CIRCUIT DIAGRAM AND REVERSE RECOVERY TIME CHARACTERISTIC

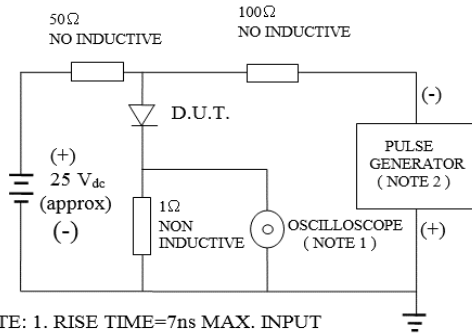

NOTE: 1. RISE TIME=7ns MAX. INPUT IMPEDANCE=1 MOhms 22PF  
 2. RISE TIME =10ns MAX. SOURCE IMPEDANCE=50 OHMS

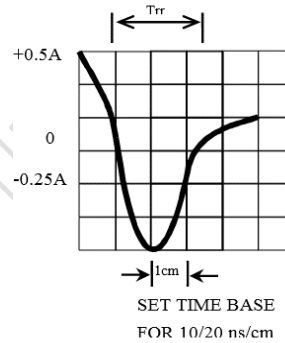

FIG. 2-TYPICAL FORWARD CURRENT DERATING CURVE

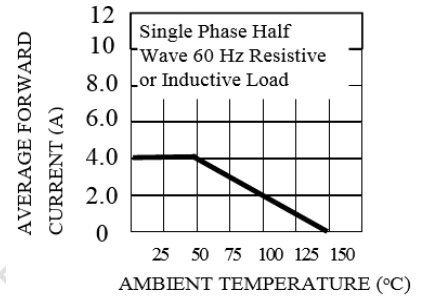

FIG. 3-TYPICAL REVERSE CHARACTERISTICS

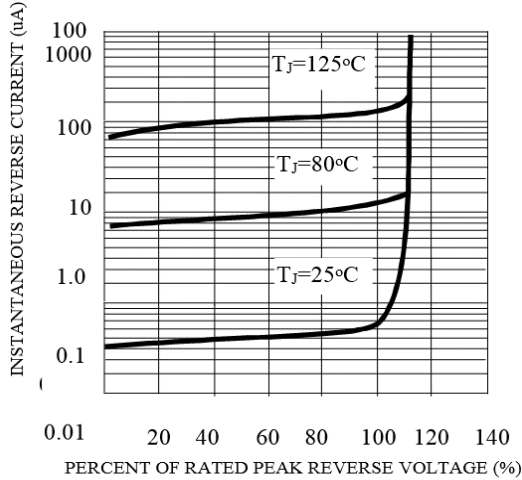

FIG. 4-TYPICAL INSTANTANEOUS FORWARD CHARACTERISTICS

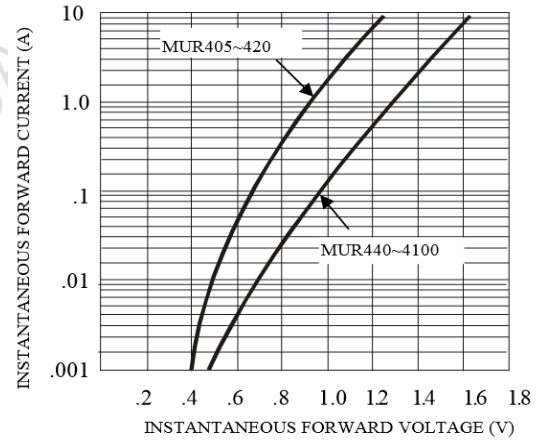

FIG. 5-MAXIMUM NON-REPETITIVE FORWARD SURGE CURRENT

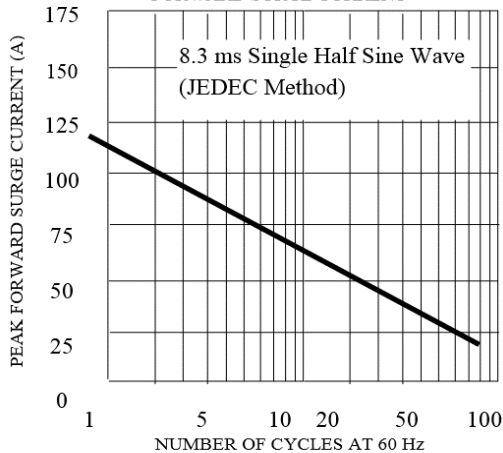

FIG. 6-TYPICAL JUNCTION CAPACITANCE

