

Integrated Silicon Pressure Sensor On-Chip Signal Conditioned, Temperature Compensated and Calibrated

**MPX5700
 Series**

0 to 700 kPa (0 to 101.5 psi)
 15 to 700 kPa (2.18 to 101.5 psi)
 0.2 to 4.7 V Output

The MPX5700 series piezoresistive transducer is a state-of-the-art monolithic silicon pressure sensor designed for a wide range of applications, but particularly those employing a microcontroller or microprocessor with A/D inputs. This patented, single element transducer combines advanced micromachining techniques, thin-film metallization, and bipolar processing to provide an accurate, high level analog output signal that is proportional to the applied pressure.

Features

- 2.5% Maximum Error over 0° to 85°C
- Ideally Suited for Microprocessor or Microcontroller-Based Systems
- Available in Absolute, Differential and Gauge Configurations
- Patented Silicon Shear Stress Strain Gauge
- Durable Epoxy Unibody Element

ORDERING INFORMATION								
Device Name	Case No.	# of Ports			Pressure Type			Device Name
		None	Single	Dual	Gauge	Differential	Absolute	
Unibody Package (MPX5700 Series)								
MPX5700A	867	•					•	MPX5700A
MPX5700AP	867B		•				•	MPX5700AP
MPX5700AS	867E		•				•	MPX5700A
MPX5700ASX	867F		•				•	MPX5700A
MPX5700D	867	•				•		MPX5700D
MPX5700DP	867C			•		•		MPX5700DP
MPX5700GP	867B		•		•			MPX5700GP
MPX5700GP1 ⁽¹⁾	867B		•		•			MPX5700GP
MPX5700GS	867E		•		•			MPX5700D

1. MPX5700GP1 has 90 degree lead form.

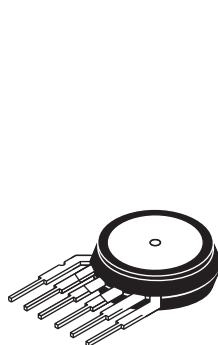
UNIBODY PACKAGES

MPX5700A/D
 CASE 867-08

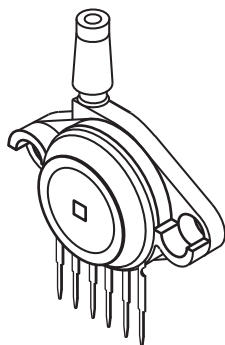

MPX5700AP/GP/GP1
 CASE 867B-04

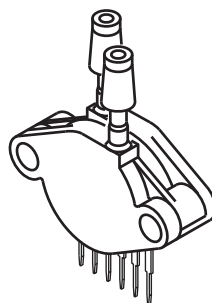

MPX5700DP
 CASE 867C-05

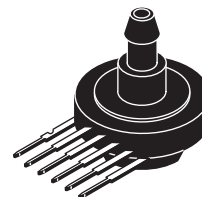

MPX5700AS/GS
 CASE 867E-03

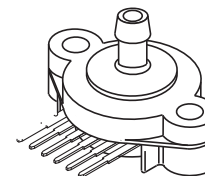

MPX5700ASX
 CASE 867F-03

Operating Characteristics

Table 1. Operating Characteristics ($V_S = 5.0$ Vdc, $T_A = 25^\circ\text{C}$ unless otherwise noted, $P_1 > P_2$. Decoupling circuit shown in required to meet electrical specifications.)

Characteristic	Symbol	Min	Typ	Max	Unit
Pressure Range ⁽¹⁾ Gauge, Differential: MPX5700D Absolute: MPX5700A	P_{OP}	0 15	— —	700 700	kPa
Supply Voltage ⁽²⁾	V_S	4.75	5.0	5.25	Vdc
Supply Current	I_O	—	7.0	10	mAdc
Zero Pressure Offset ⁽³⁾ Gauge, Differential (0 to 85°C) Absolute (0 to 85°C)	V_{off}	0.088 0.184	0.2 —	0.313 0.409	Vdc
Full Scale Output ⁽⁴⁾ (0 to 85°C)	V_{FSO}	4.587	4.7	4.813	Vdc
Full Scale Span ⁽⁵⁾ (0 to 85°C)	V_{FSS}	—	4.5	—	Vdc
Accuracy ⁽⁶⁾ (0 to 85°C)	—	—	—	±2.5	% V_{FSS}
Sensitivity	V/P	—	6.4	—	mV/kPa
Response Time ⁽⁷⁾	t_R	—	1.0	—	ms
Output Source Current at Full Scale Output	I_{O+}	—	0.1	—	mAdc
Warm-Up Time ⁽⁸⁾	—	—	20	—	ms

- 1.0 kPa (kiloPascal) equals 0.145 psi.
- Device is ratiometric within this specified excitation range.
- Offset (V_{off}) is defined as the output voltage at the minimum rated pressure.
- Full Scale Output (V_{FSO}) is defined as the output voltage at the maximum or full rated pressure.
- Full Scale Span (V_{FSS}) is defined as the algebraic difference between the output voltage at full rated pressure and the output voltage at the minimum rated pressure.
- Accuracy (error budget) consists of the following:
 - Linearity: Output deviation from a straight line relationship with pressure over the specified pressure range.
 - Temperature Hysteresis: Output deviation at any temperature within the operating temperature range, after the temperature is cycled to and from the minimum or maximum operating temperature points, with zero differential pressure applied.
 - Pressure Hysteresis: Output deviation at any pressure within the specified range, when this pressure is cycled to and from the minimum or maximum rated pressure, at 25°C.
 - TcSpan: Output deviation over the temperature range of 0° to 85°C, relative to 25°C.
 - TcOffset: Output deviation with minimum rated pressure applied, over the temperature range of 0° to 85°C, relative to 25°C.
 - Variation from Nominal: The variation from nominal values, for Offset or Full Scale Span, as a percent of V_{FSS} , at 25°C.
- Response Time is defined as the time for the incremental change in the output to go from 10% to 90% of its final value when subjected to a specified step change in pressure.
- Warm-up Time is defined as the time required for the device to meet the specified output voltage after the pressure has been stabilized.

Maximum Ratings

Table 2. Maximum Ratings⁽¹⁾

Parametrics	Symbol	Value	Unit
Maximum Pressure ⁽²⁾ ($P2 \leq 1$ Atmosphere)	$P1_{max}$	2800	kPa
Storage Temperature	T_{stg}	-40 to +125	°C
Operating Temperature	T_A	-40 to +125	°C

- Maximum Ratings apply to Case 867 only. Extended exposure at the specified limits may cause permanent damage or degradation to the device.
- This sensor is designed for applications where P1 is always greater than, or equal to P2. P2 maximum is 500 kPa.

Figure 1 shows a block diagram of the internal circuitry integrated on a pressure sensor chip.

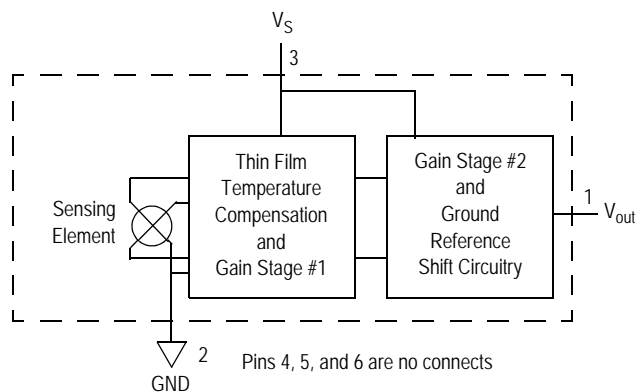

Figure 1. Fully Integrated Pressure Sensor Schematic

On-chip Temperature Compensation and Calibration

Figure 3 illustrates both the Differential/Gauge and the Absolute Sensing Chip in the basic chip carrier (Case 867). A fluorosilicone gel isolates the die surface and wire bonds from the environment, while allowing the pressure signal to be transmitted to the sensor diaphragm. (For use of the MPX5700D in a high-pressure cyclic application, consult the factory.)

The MPX5700 series pressure sensor operating characteristics, and internal reliability and qualification tests are based on use of dry air as the pressure media. Media, other than dry air, may have adverse effects on sensor

performance and long-term reliability. Contact the factory for information regarding media compatibility in your application.

Figure 2 shows the sensor output signal relative to pressure input. Typical, minimum, and maximum output curves are shown for operation over a temperature range of 0° to 85°C using the decoupling circuit shown in . The output will saturate outside of the specified pressure range.

shows the recommended decoupling circuit for interfacing the output of the integrated sensor to the A/D input of a microprocessor or microcontroller. Proper decoupling of the power supply is recommended.

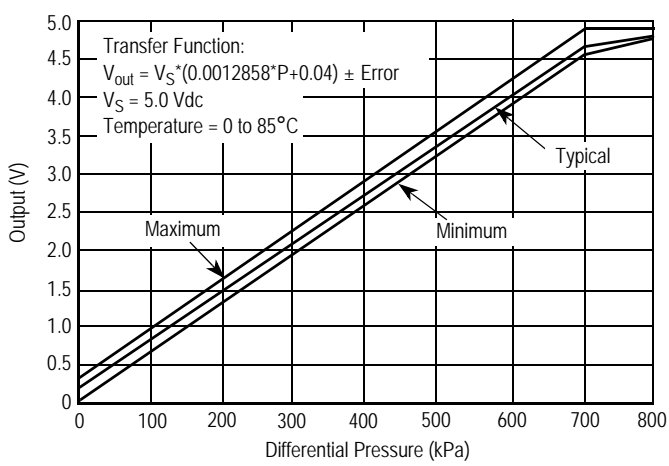

Figure 2. Output vs. Pressure Differential

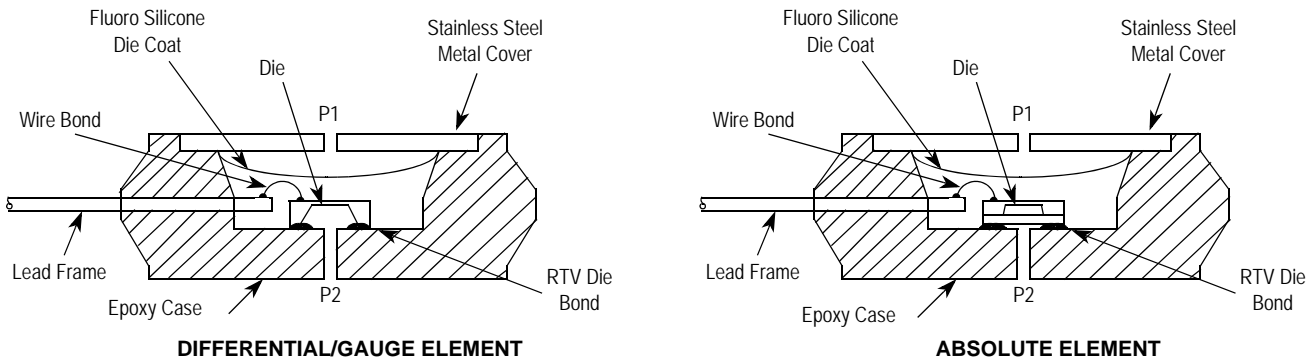

Figure 3. Cross-Sectional Diagrams (not to scale)

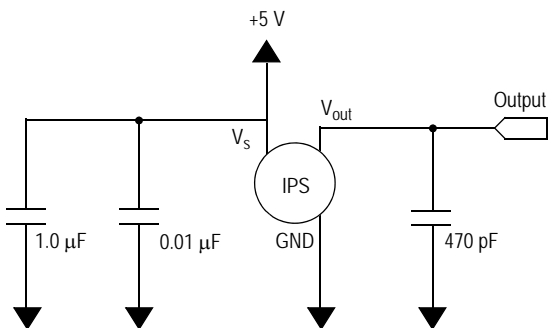

Figure 4. Recommended Power Supply Decoupling and Output Filtering (For additional output filtering, please refer to Application Note AN1646)

PRESSURE (P1)/VACUUM (P2) SIDE IDENTIFICATION TABLE

Freescale designates the two sides of the pressure sensor as the Pressure (P1) side and the Vacuum (P2) side. The Pressure (P1) side is the side containing fluorosilicone gel which protects the die from harsh media. The Freescale MPX

pressure sensor is designed to operate with positive differential pressure applied, $P1 > P2$.

The Pressure (P1) side may be identified by using the following table.

Part Number	Case Type	Pressure (P1) Side Identifier
MPX5700A/D	867	Stainless Steel Cap
MPX5700DP	867C	Side with Part Marking
MPX5700GP/AP	867B	Side with Port Attached
MPX5700GS/AS	867E	Side with Port Attached
MPX5700ASX	867F	Side with Port Attached

PACKAGE DIMENSIONS

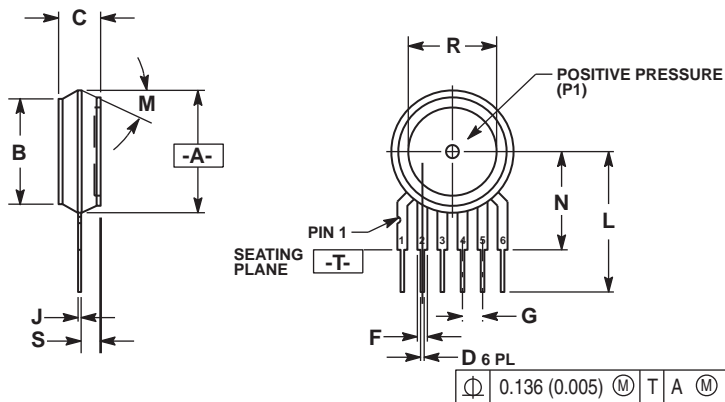

- NOTES:
1. DIMENSIONING AND TOLERANCING PER ANSI Y14.5M, 1982.
 2. CONTROLLING DIMENSION: INCH.
 3. DIMENSION -A- IS INCLUSIVE OF THE MOLD STOP RING. MOLD STOP RING NOT TO EXCEED 16.00 (0.630).

DIM	INCHES		MILLIMETERS	
	MIN	MAX	MIN	MAX
A	0.595	0.630	15.11	16.00
B	0.514	0.534	13.06	13.56
C	0.200	0.220	5.08	5.59
D	0.027	0.033	0.68	0.84
F	0.048	0.064	1.22	1.63
G	0.100 BSC		2.54 BSC	
J	0.014	0.016	0.36	0.40
L	0.695	0.725	17.65	18.42
M	30° NOM		30° NOM	
N	0.475	0.495	12.07	12.57
R	0.430	0.450	10.92	11.43
S	0.090	0.105	2.29	2.66

- STYLE 1:
 PIN 1. VOUT
 2. GROUND
 3. VCC
 4. V1
 5. V2
 6. VEX

- STYLE 2:
 PIN 1. OPEN
 2. GROUND
 3. -VOUT
 4. VSUPPLY
 5. +VOUT
 6. OPEN

- STYLE 3:
 PIN 1. OPEN
 2. GROUND
 3. +VOUT
 4. +VSUPPLY
 5. -VOUT
 6. OPEN

CASE 867-08 ISSUE N BASIC ELEMENT

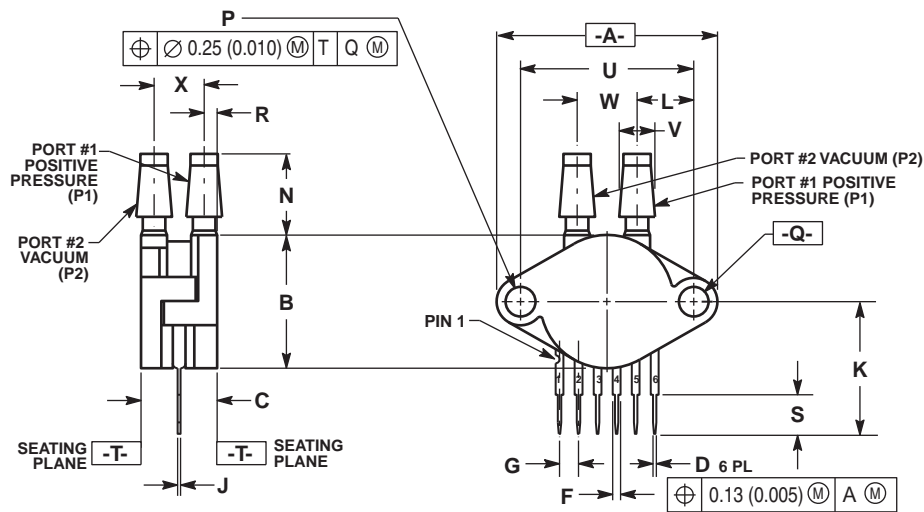

- NOTES:
1. DIMENSIONING AND TOLERANCING PER ASME Y14.5M, 1994.
 2. CONTROLLING DIMENSION: INCH.

DIM	INCHES		MILLIMETERS	
	MIN	MAX	MIN	MAX
A	1.145	1.175	29.08	29.85
B	0.685	0.715	17.40	18.16
C	0.405	0.435	10.29	11.05
D	0.027	0.033	0.68	0.84
F	0.048	0.064	1.22	1.63
G	0.100 BSC		2.54 BSC	
J	0.014	0.016	0.36	0.41
K	0.695	0.725	17.65	18.42
L	0.290	0.300	7.37	7.62
N	0.420	0.440	10.67	11.18
P	0.153	0.159	3.89	4.04
Q	0.153	0.159	3.89	4.04
R	0.063	0.083	1.60	2.11
S	0.220	0.240	5.59	6.10
U	0.910 BSC		23.11 BSC	
V	0.182	0.194	4.62	4.93
W	0.310	0.330	7.87	8.38
X	0.248	0.278	6.30	7.06

- STYLE 1:
 PIN 1. VOUT
 2. GROUND
 3. VCC
 4. V1
 5. V2
 6. VEX

CASE 867C-05 ISSUE F PRESSURE AND VACUUM SIDES PORTED (DP)

PACKAGE DIMENSIONS

NOTES:

1. DIMENSIONS ARE IN MILLIMETERS.
2. DIMENSIONS AND TOLERANCES PER ASME Y14.5M-1994.
3. 867B-01 THRU -3 OBSOLETE, NEW STANDARD 867B-04.

STYLE 1:

- PIN 1: V OUT
 2: GROUND
 3: VCC
 4: V1
 5: V2
 6: V EX

© FREESCALE SEMICONDUCTOR, INC. ALL RIGHTS RESERVED.	MECHANICAL OUTLINE	PRINT VERSION NOT TO SCALE	
TITLE: SENSOR, 6 LEAD UNIBODY CELL, AP & GP 01ASB09087B	DOCUMENT NO: 98ASB42796B	REV: G	
	CASE NUMBER: 867B-04	28 JUL 2005	
	STANDARD: NON-JEDEC		

PAGE 2 OF 2

CASE 867B-04
ISSUE G
PRESSURE SIDE PORTED (AP, GP)

PACKAGE DIMENSIONS

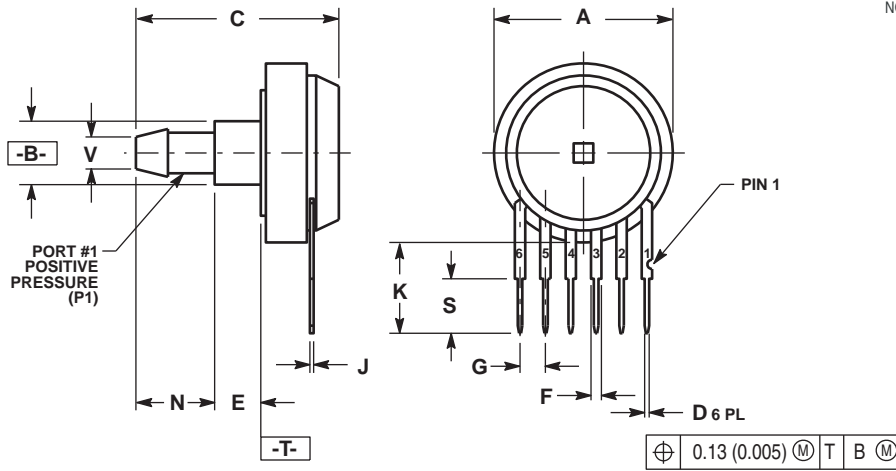

- NOTES:
1. DIMENSIONING AND TOLERANCING PER ANSI Y14.5M, 1982.
 2. CONTROLLING DIMENSION: INCH.

DIM	INCHES		MILLIMETERS	
	MIN	MAX	MIN	MAX
A	0.690	0.720	17.53	18.28
B	0.245	0.255	6.22	6.48
C	0.780	0.820	19.81	20.82
D	0.027	0.033	0.69	0.84
E	0.178	0.186	4.52	4.72
F	0.048	0.064	1.22	1.63
G	0.100 BSC		2.54 BSC	
J	0.014	0.016	0.36	0.41
K	0.345	0.375	8.76	9.53
N	0.300	0.310	7.62	7.87
S	0.220	0.240	5.59	6.10
V	0.182	0.194	4.62	4.93

- STYLE 1:
1. V_{OUT}
 2. GROUND
 3. V_{CC}
 4. V1
 5. V2
 6. V_{EX}

**CASE 867E-03
ISSUE D
PRESSURE SIDE PORTED (AS, GS)**

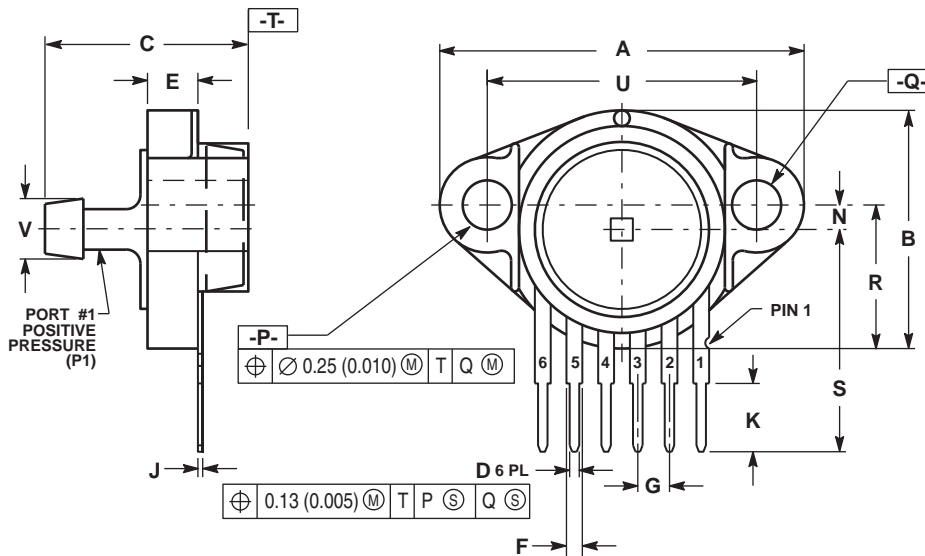

- NOTES:
1. DIMENSIONING AND TOLERANCING PER ANSI Y14.5M, 1982.
 2. CONTROLLING DIMENSION: INCH.

DIM	INCHES		MILLIMETERS	
	MIN	MAX	MIN	MAX
A	1.080	1.120	27.43	28.45
B	0.740	0.760	18.80	19.30
C	0.630	0.650	16.00	16.51
D	0.027	0.033	0.68	0.84
E	0.160	0.180	4.06	4.57
F	0.048	0.064	1.22	1.63
G	0.100 BSC		2.54 BSC	
J	0.014	0.016	0.36	0.41
K	0.220	0.240	5.59	6.10
N	0.070	0.080	1.78	2.03
P	0.150	0.160	3.81	4.06
Q	0.150	0.160	3.81	4.06
R	0.440	0.460	11.18	11.68
S	0.695	0.725	17.65	18.42
U	0.840	0.860	21.34	21.84
V	0.182	0.194	4.62	4.93

- STYLE 1:
1. V_{OUT}
 2. GROUND
 3. V_{CC}
 4. V1
 5. V2
 6. V_{EX}

**CASE 867F-03
ISSUE D
PRESSURE SIDE AXIAL PORT (ASX)**

Table 3. Revision History

Revision number	Revision date	Description of changes
10	10/2012	<ul style="list-style-type: none"> On page 1, added a table note to the Ordering Information table indicating that the device MPX5700GP1 has 90 degree lead form.

How to Reach Us:

Home Page:
freescale.com

Web Support:
freescale.com/support

Information in this document is provided solely to enable system and software implementers to use Freescale products. There are no express or implied copyright licenses granted hereunder to design or fabricate any integrated circuits based on the information in this document.

Freescale reserves the right to make changes without further notice to any products herein. Freescale makes no warranty, representation, or guarantee regarding the suitability of its products for any particular purpose, nor does Freescale assume any liability arising out of the application or use of any product or circuit, and specifically disclaims any and all liability, including without limitation consequential or incidental damages. "Typical" parameters that may be provided in Freescale data sheets and/or specifications can and do vary in different applications, and actual performance may vary over time. All operating parameters, including "typicals," must be validated for each customer application by customer's technical experts. Freescale does not convey any license under its patent rights nor the rights of others. Freescale sells products pursuant to standard terms and conditions of sale, which can be found at the following address: freescale.com/salestermsandconditions.

Freescale, the Freescale logo, Energy Efficient Solutions logo, are trademarks of Freescale Semiconductor, Inc., Reg. U.S. Pat. & Tm. Off. Xtrinsic is a trademark of Freescale Semiconductor, Inc. All other product or service names are the property of their respective owners.

© 2012 Freescale Semiconductor, Inc.