



MP3V5050, 0 to 50 kPa, Differential, and Gauge Pressure Sensor

The MP3V5050 series piezoresistive transducer is a state-of-the-art, monolithic silicon, pressure sensor designed for a wide range of applications, but particularly those employing a microcontroller or microprocessor with A/D inputs. This patented, single element transducer combines advanced micromachining techniques, thin-film metallization, and bipolar processing to provide an accurate, high level analog output signal that is proportional to the applied pressure.

Features

- 2.5% maximum error over 0 °C to 85 °C
- Ideally suited for microprocessor or microcontroller-based systems
- Temperature compensated over -40 °C to +125 °C
- Patented silicon shear stress strain gauge
- Thermoplastic (PPS) surface mount package
- Multiple porting options for design flexibility
- Barbed side ports for robust tube connection

Application examples

- Pump/motor control
- Robotics
- Level detectors
- Medical diagnostics
- Pressure switching
- Blood pressure measurement

MP3V5050

Small outline package

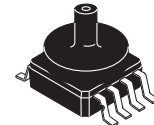

MP3V5050GC6U/6T1
Case 98ASB17757C

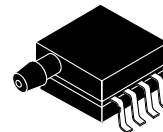

MP3V5050GP
Case 98ASA99303D

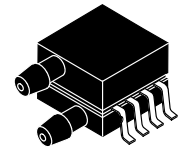

MP3V5050DP
Case 98ASA99255D

Top view

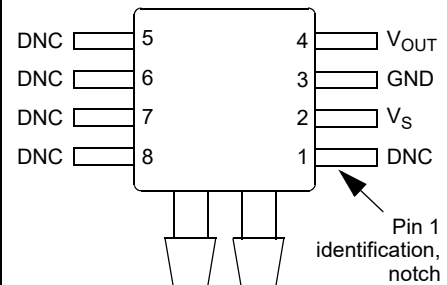

Pinout

Ordering information									
Part number	Shipping	Package	# of Ports			Pressure Type			Device marking
			None	Single	Dual	Gauge	Differential	Absolute	
MP3V5050DP	Tray	98ASA99255D			•		•		MP3V5050DP
MP3V5050GP	Tray	98ASA99303D		•		•			MP3V5050GP
MP3V5050GC6U	Rail	98ASB17757C		•		•			MP3V5050G
MP3V5050GC6T1	Reel	98ASB17757C		•		•			MP3V5050G

NXP reserves the right to change the detail specifications as may be required to permit improvements in the design of its products.

© 2008, 2009, 2015, 2017, 2018 NXP B.V. All rights reserved.



Contents

1	General Description	3
1.1	Block diagram	3
1.2	Pinout	3
2	Mechanical and Electrical Specifications	4
2.1	Maximum ratings	4
2.2	Operating characteristics	4
3	On-chip Temperature Compensation and Calibration	5
4	Package Information	7
4.1	Pressure source 1 (P1)/Pressure source 2 (P2) side identification	7
4.2	Minimum recommended footprint for surface mounted applications	7
4.3	Package dimensions	8
5	Revision History	14

Related Documentation

The MP3V5050 device features and operations are described in a variety of reference manuals, user guides, and application notes. To find the most-current versions of these documents:

1. Go to the MP3V5050 product page at <http://www.nxp.com/MP3V5050>
2. Click on the Documentation tab.

1 General Description

1.1 Block diagram

Figure 1 shows a block diagram of the internal circuitry integrated on a pressure sensor chip.

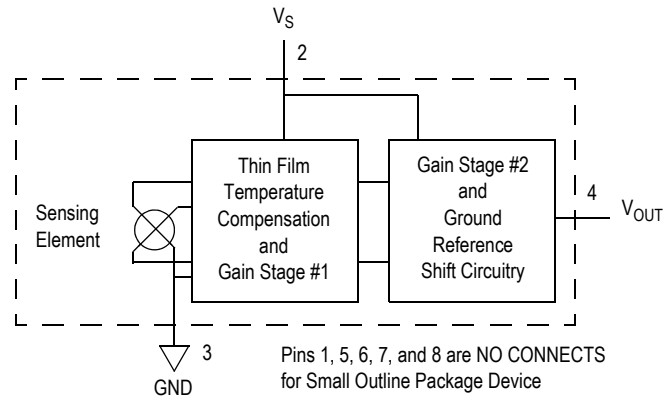

Figure 1. Fully integrated pressure sensor block diagram

1.2 Pinout

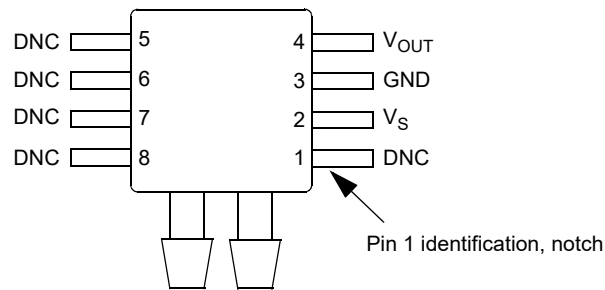

Figure 2. Device pinout (top view)

Table 1. Pin functions

Pin	Name	Function
1	DNC	Do not connect to external circuitry or ground. Pin 1 is denoted by notch.
2	V_S	Voltage supply
3	GND	Ground
4	V_{OUT}	Output voltage
5	DNC	Do not connect to external circuitry or ground.
6	DNC	Do not connect to external circuitry or ground.
7	DNC	Do not connect to external circuitry or ground.
8	DNC	Do not connect to external circuitry or ground.

2 Mechanical and Electrical Specifications

2.1 Maximum ratings

Table 2. Maximum ratings⁽¹⁾

Rating	Symbol	Value	Unit
Maximum pressure (P1 > P2)	P _{max}	200	kPa
Storage temperature	T _{stg}	-40 to +125	°C
Operating temperature	T _A	-40 to +125	°C

1.Exposure beyond the specified limits may cause permanent damage or degradation to the device.

2.2 Operating characteristics

Table 3. Operating characteristics (V_S = 3.0 V_{DC}, T_A = 25 °C unless otherwise noted, P1 > P2. Decoupling circuit shown in [Figure 5](#) required to meet electrical specifications.)

Characteristic	Symbol	Min	Typ	Max	Unit
Pressure range ⁽¹⁾	P _{OP}	0	—	50	kPa
Supply voltage ⁽²⁾	V _S	2.7	3.0	3.3	V _{DC}
Supply current	I _O	—	7.0	10	mAdc
Minimum pressure offset ⁽³⁾ (0 °C to 85 °C) @ V _S = 3.0 Volts	V _{OFF}	0.053	0.12	0.188	V _{DC}
Full-scale output ⁽⁴⁾ (0 °C to 85 °C) @ V _S = 3.0 Volts	V _{FSS}	2.752	2.8	2.888	V _{DC}
Full-scale span ⁽⁵⁾ (0 °C to 85 °C) @ V _S = 3.0 Volts	V _{FSS}	—	2.7	—	V _{DC}
Accuracy ⁽⁶⁾ (0 °C to 85 °C)	—	—	—	±2.5	%V _{FSS}
Sensitivity	V/P	—	54	—	mV/kPa
Response time ⁽⁷⁾	t _R	—	1.0	—	ms
Output source current at full-scale output	I _{O+}	—	0.1	—	mAdc
Warm-up time ⁽⁸⁾	—	—	20	—	ms
Offset stability ⁽⁹⁾	—	—	±0.5	—	%V _{FSS}

1. 1.0 kPa (kilopascal) equals 0.145 psi.

2.Device is ratiometric within this specified excitation range.

3.Offset (V_{off}) is defined as the output voltage at the minimum rated pressure.

4.Full-scale Output (V_{FSS}) is defined as the output voltage at the maximum or full-rated pressure.

5.Full-scale Span (V_{FSS}) is defined as the algebraic difference between the output voltage at full-rated pressure and the output voltage at the minimum rated pressure.

6.Accuracy (error budget) consists of the following:

Linearity: Output deviation from a straight line relationship with pressure over the specified pressure range.

Temperature Hysteresis: Output deviation at any temperature within the operating temperature range, after the temperature is cycled to and from the minimum or maximum operating temperature points, with zero differential pressure applied.

Pressure Hysteresis: Output deviation at any pressure within the specified range, when this pressure is cycled to and from the minimum or maximum rated pressure at 25 °C.

TcSpan: Output deviation over the temperature range of 0 °C to 85 °C, relative to 25 °C.

TcOffset: Output deviation with minimum pressure applied, over the temperature range of 0 °C to 85 °C, relative to 25 °C.

Variation from nominal: The variation from nominal values, for offset or full-scale span, as a percent of V_{FSS} at 25 °C.

7.Response time is defined as the time for the incremental change in the output to go from 10% to 90% of its final value when subjected to a specified step change in pressure.

8.Warm-up time is defined as the time required for the product to meet the specified output voltage after the pressure has been stabilized.

9.Offset stability is the product's output deviation when subjected to 1000 hours of pulsed pressure, temperature cycling with bias test.

3 On-chip Temperature Compensation and Calibration

The MP3V5050 series pressure sensor operating characteristics, and internal reliability and qualification tests are based on use of dry air as the pressure media. Media, other than dry air, may have adverse effects on sensor performance and long-term reliability. Contact the factory for information regarding media compatibility in your application.

Figure 3 shows the sensor output signal relative to pressure input. Typical, minimum, and maximum output curves are shown for operation over a temperature range of 0 °C to 85 °C using the decoupling circuit shown in Figure 5. The output will saturate outside of the specified pressure range.

Figure 4 illustrates the Differential/Gauge Sensing Chip in the basic chip carrier (case 98ASB17757C). A fluorosilicone gel isolates the die surface and wire bonds from the environment, while allowing the pressure signal to be transmitted to the sensor diaphragm.

Figure 5 shows the recommended decoupling circuit for interfacing the output of the integrated sensor to the A/D input of a microprocessor or microcontroller. Proper decoupling of the power supply is recommended.

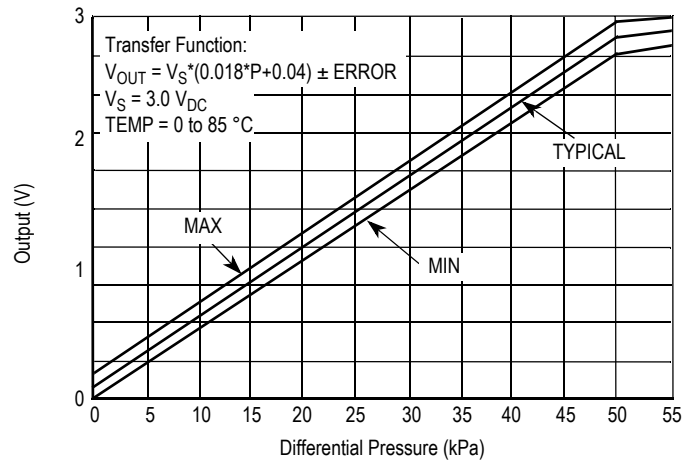

Figure 3. Output versus Pressure differential

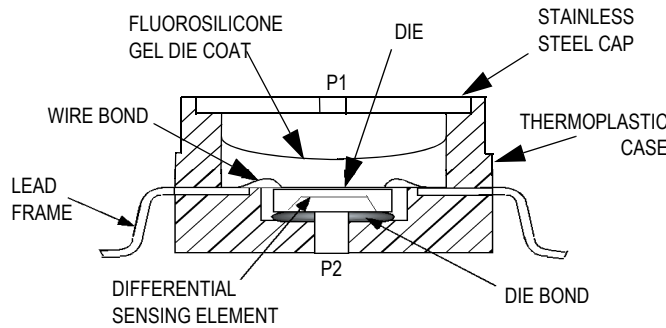

Figure 4. Cross-sectional diagram SOP (not to scale)

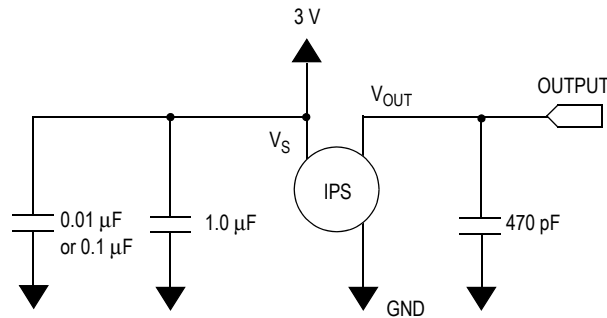
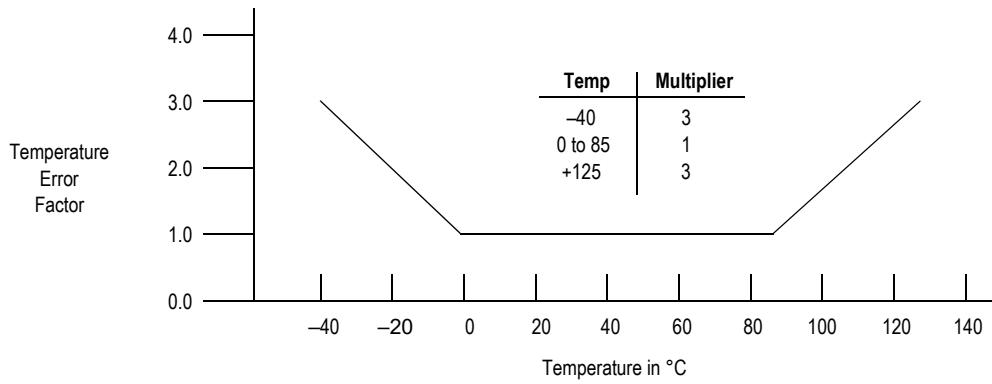

Figure 5. Recommended power supply decoupling and output filtering
 (For additional output filtering, please refer to Application Note AN1646)

Nominal Transfer Value: $V_{OUT} = V_S (P \times 0.018 + 0.04)$
 $\pm (\text{Pressure Error} \times \text{Temp. Factor} \times 0.018 \times V_S)$
 $V_S = 3.0 \text{ V} \pm 0.30 \text{ V}_{DC}$

Figure 6. Transfer function



NOTE: The Temperature Multiplier is a linear response from 0 °C to -40 °C and from 85 °C to 125 °C.

Figure 7. Temperature error band

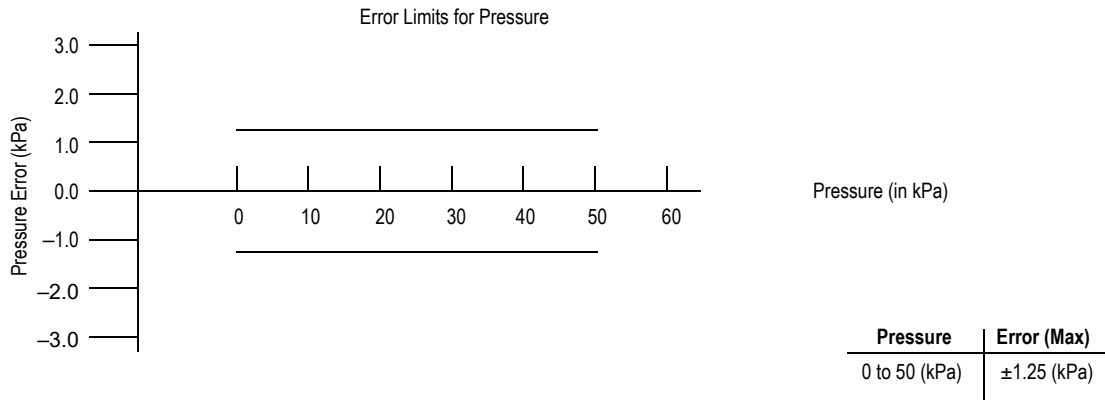

Figure 8. Pressure error band

4 Package Information

4.1 Pressure source 1 (P1)/Pressure source 2 (P2) side identification

NXP Semiconductors designates the two sides of the pressure sensor as the Pressure source 1 (P1) side and Pressure source 2 (P2) side. The Pressure (P1) side is the side containing fluorosilicone gel which protects the die from harsh media. The MP3V pressure sensor is designed to operate with positive differential pressure applied, $P1 > P2$.

The Pressure (P1) side may be identified by using the table below:

Table 4. Pressure source 1 (P1)/Pressure source 2 (P2) side identification table

Part number	Case number	Pressure (P1) side identifier
MP3V5050GP	98ASA99303D	Side with port attached
MP3V5050DP	98ASA99255D	P1 is identified as the top-side port, above the leads.
MP3V5050GC6U/T1	98ASB17757C	Vertical port attached

4.2 Minimum recommended footprint for surface mounted applications

Surface mount board layout is a critical portion of the total design. The footprint for the surface mount packages must be the correct size to ensure proper solder connection interface between the board and the package. With the correct footprint, the packages will self align when subjected to a solder reflow process. It is always recommended to design boards with a solder mask layer to avoid bridging and shorting between solder pads.

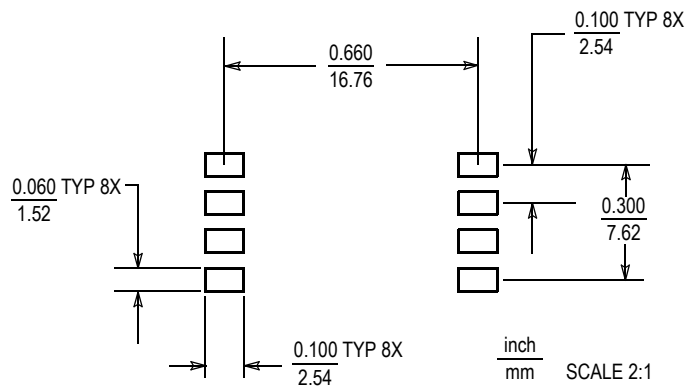

Figure 9. SOP footprint (case 98ASB17757C)



NOTES:

1. DIMENSIONING AND TOLERANCING PER ANSI Y14.5M-1982.
2. CONTROLLING DIMENSION: INCH.
3. DIMENSION 'A' AND 'B' DO NOT INCLUDE MOLD PROTUSION.
4. MAXIMUM MOLD PROTRUSION 0.15 (0.006).
5. ALL VERTICAL SURFACES 5° TYPICAL DRAFT.

DIM	INCHES		MILLIMETERS			
	MIN	MAX	MIN	MAX		
A	0.415	0.425	10.54	10.79		
B	0.415	0.425	10.54	10.79		
C	0.500	0.520	12.70	13.21		
D	0.038	0.042	0.96	1.07		
G	0.100	BSC	2.54	BSC		
H	0.002	0.010	0.05	0.25		
J	0.009	0.011	0.23	0.28		
K	0.061	0.071	1.55	1.80		
M	0°	7°	0°	7°		
N	0.444	0.448	11.28	11.38		
S	0.709	0.725	18.01	18.41		
V	0.245	0.255	6.22	6.48		
W	0.115	0.125	2.92	3.17		
© NXP SEMICONDUCTORS N.V. ALL RIGHTS RESERVED			MECHANICAL OUTLINE		PRINT VERSION NOT TO SCALE	
TITLE: SENSOR UNIBODY, 11.33 X 11.33 X 12.955 PKG, 2.54 PITCH, 8 I/O			DOCUMENT NO: 98ASB17757C		REV: C	
			STANDARD: NON-JEDEC			
			SOT1854-1		13 JUL 2017	

PAGE 2 OF 2

Case 98ASB17757C, small outline package

MP3V5050

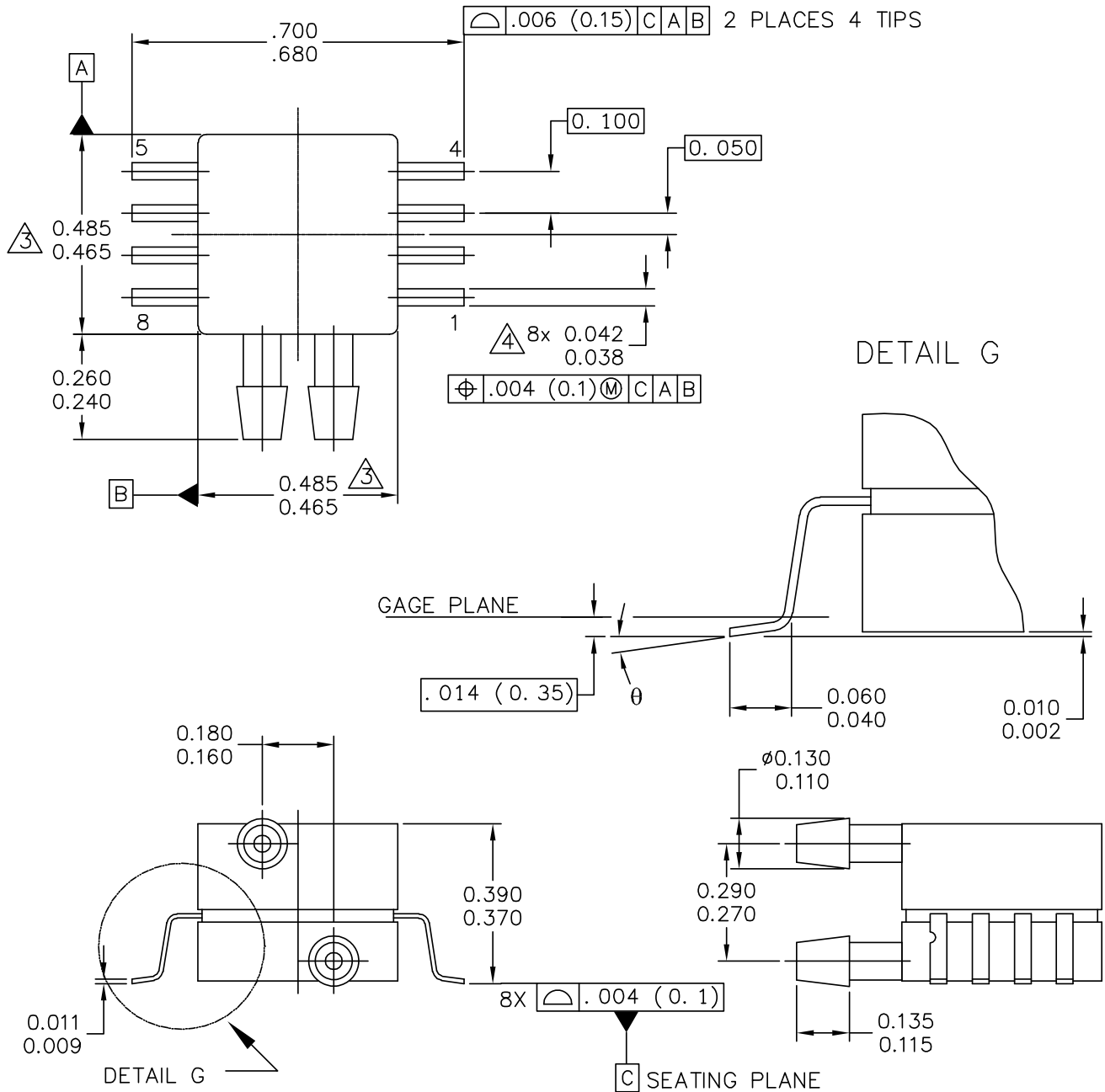

© NXP SEMICONDUCTORS N. V. ALL RIGHTS RESERVED	MECHANICAL OUTLINE	PRINT VERSION NOT TO SCALE
TITLE: 8 LD SNSR, DUAL PORT	DOCUMENT NO: 98ASA99255D	REV: B
	STANDARD: NON-JEDEC	
	SOT1693-1	14 MAR 2016

Case 98ASA99255D, small outline package



NOTES:

1. CONTROLLING DIMENSION: INCH

2. INTERPRET DIMENSIONS AND TOLERANCES PER ASME Y14.5M-1994.

3. DIMENSIONS DO NOT INCLUDE MOLD FLASH OR PROTRUSIONS.
MOLD FLASH AND PROTRUSIONS SHALL NOT EXCEED .006 PER SIDE.

4. DIMENSION DOES NOT INCLUDE DAMBAR PROTRUSION. ALLOWABLE DAMBAR
PROTRUSION SHALL BE .008 MAXIMUM.

STYLE 1:

PIN 1: GND
PIN 2: +Vout
PIN 3: Vs
PIN 4: -Vout
PIN 5: N/C
PIN 6: N/C
PIN 7: N/C
PIN 8: N/C

STYLE 2:

PIN 1: N/C
PIN 2: Vs
PIN 3: GND
PIN 4: Vout
PIN 5: N/C
PIN 6: N/C
PIN 7: N/C
PIN 8: N/C

© NXP SEMICONDUCTORS N. V. ALL RIGHTS RESERVED	MECHANICAL OUTLINE	PRINT VERSION NOT TO SCALE
TITLE: 8 LD SNSR, DUAL PORT	DOCUMENT NO: 98ASA99255D STANDARD: NON-JEDEC SOT1693-1	REV: B 14 MAR 2016

PAGE 2 OF 2

Case 98ASA99255D, small outline package

MP3V5050

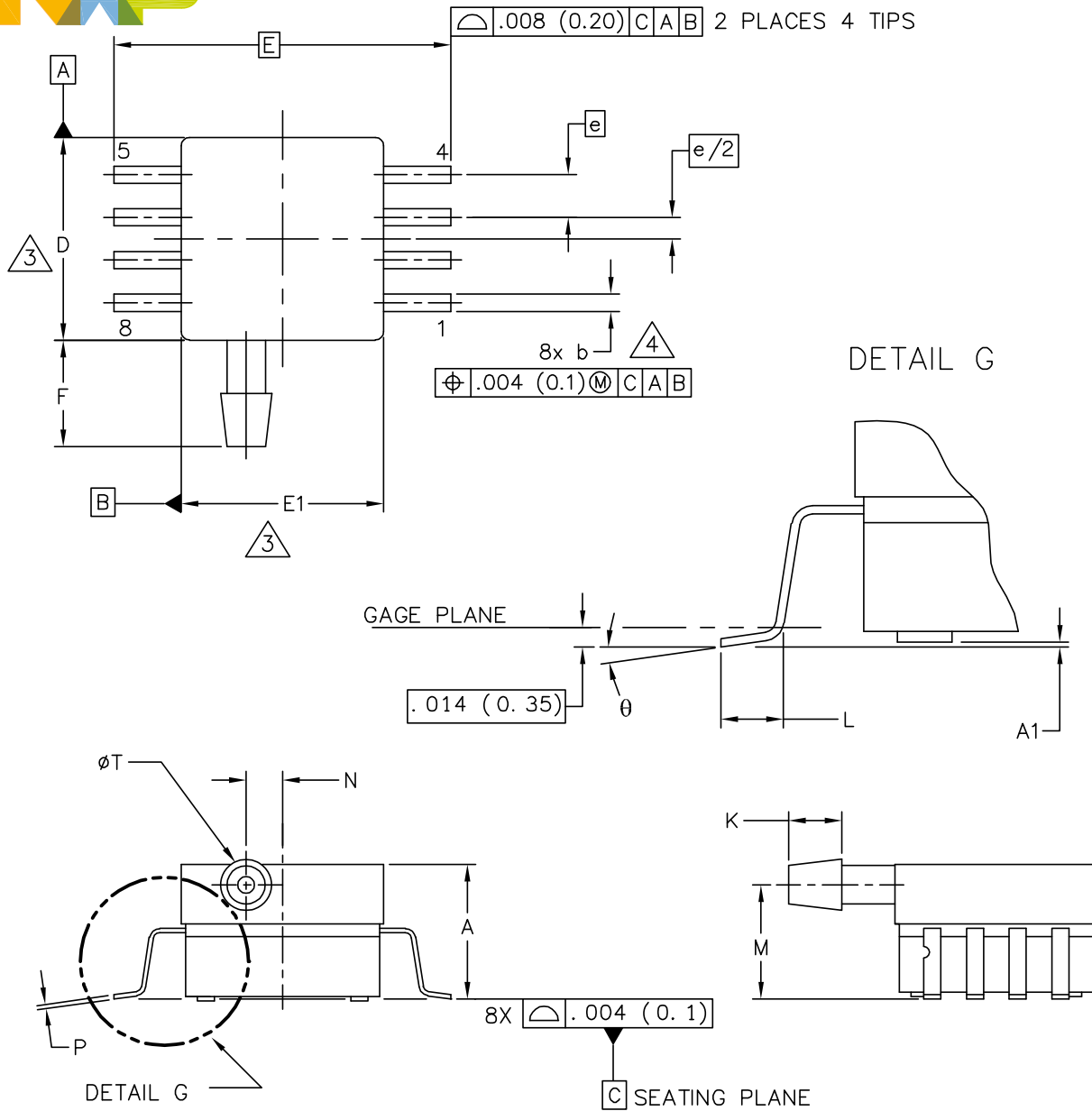

© NXP SEMICONDUCTORS N. V. ALL RIGHTS RESERVED	MECHANICAL OUTLINE	PRINT VERSION NOT TO SCALE
TITLE:	DOCUMENT NO: 98ASA99303D	REV: E
8 LD SOP, SIDE PORT	STANDARD: NON-JEDEC	
	SOT1693-3	14 MAR 2016

Case 98ASA99303D, small outline package

MP3V5050



NOTES:

1. CONTROLLING DIMENSION: INCH
 2. INTERPRET DIMENSIONS AND TOLERANCES PER ASME Y14.5M-1994.
- ③ DIMENSIONS DO NOT INCLUDE MOLD FLASH OR PROTRUSIONS.
MOLD FLASH AND PROTRUSIONS SHALL NOT EXCEED .006 (0.152) PER SIDE.
- ④ DIMENSION DOES NOT INCLUDE DAMBAR PROTRUSION. ALLOWABLE DAMBAR PROTRUSION SHALL BE .008 (0.203) MAXIMUM.

DIM	INCHES		MILLIMETERS		DIM	INCHES		MILLIMETERS	
	MIN	MAX	MIN	MAX		MIN	MAX	MIN	MAX
A	.300	.330	7.62	8.38	θ	0°	7°	0°	7°
A1	.002	.010	0.05	0.25	-	---	---	---	---
b	.038	.042	0.96	1.07	-	---	---	---	---
D	.465	.485	11.81	12.32	-	---	---	---	---
E	.717 BSC		18.21 BSC		-	---	---	---	---
E1	.465	.485	11.81	12.32	-	---	---	---	---
e	.100 BSC		2.54 BSC		-	---	---	---	---
F	.245	.255	6.22	6.47	-	---	---	---	---
K	.120	.130	3.05	3.30	-	---	---	---	---
L	.061	.071	1.55	1.80	-	---	---	---	---
M	.270	.290	6.86	7.36	-	---	---	---	---
N	.080	.090	2.03	2.28	-	---	---	---	---
P	.009	.011	0.23	0.28	-	---	---	---	---
T	.115	.125	2.92	3.17	-	---	---	---	---

© NXP SEMICONDUCTORS N. V. ALL RIGHTS RESERVED		MECHANICAL OUTLINE		PRINT VERSION NOT TO SCALE			
TITLE: 8 LD SOP, SIDE PORT			DOCUMENT NO: 98ASA99303D		REV: E		
			STANDARD: NON-JEDEC				
			SOT1693-3		14 MAR 2016		

Case 98ASA99303D, small outline package

5 Revision History

Table 5. Revision history

Revision number	Revision date	Description
1.4	08/2018	<ul style="list-style-type: none">• Replaced two occurrences of “,Äi” with “-20” and “-40” on the “Temperature in °C” axis in Figure 7.• Replaced three occurrences of “,Äi” with “-1.0”, “-2.0”, and “-3.0” on the “Pressure Error (kPa)” axis in Figure 8.• Revised “± 1.25 (kPa)” to “± 1.25 (kPa)” for “Error (Max)” in Figure 8.
1.3	11/2017	<ul style="list-style-type: none">• Corrected device marking column for MP3V5050DP and MP3V5050GP in Ordering Information table.• Corrected package numbers for devices MP3V5050GP and MP3V5050GC6U/6T1 in Ordering Information table and in illustration block.• Updated case 98ASB17757C with current drawing.
1.2	06/2017	<ul style="list-style-type: none">• Revised the case numbers for MP3V5050GP and MP3V5050GC6U/6T1.• Revised the package column of the ordering information table.• Updated “Freescale” references to “NXP.”
1.1	09/2015	<ul style="list-style-type: none">• Updated format.• Updated package drawings with current version.

How to Reach Us:

Home Page:

nxp.com

Web Support:

nxp.com/support

Information in this document is provided solely to enable system and software implementers to use NXP products. There are no express or implied copyright licenses granted hereunder to design or fabricate any integrated circuits based on the information in this document.

NXP reserves the right to make changes without further notice to any products herein. NXP makes no warranty, representation, or guarantee regarding the suitability of its products for any particular purpose, nor does NXP assume any liability arising out of the application or use of any product or circuit, and specifically disclaims any and all liability, including without limitation consequential or incidental damages. "Typical" parameters that may be provided in NXP data sheets and/or specifications can and do vary in different applications, and actual performance may vary over time. All operating parameters, including "typicals," must be validated for each customer application by customer's technical experts. NXP does not convey any license under its patent rights nor the rights of others. NXP sells products pursuant to standard terms and conditions of sale, which can be found at the following address:

nxp.com/salestermsandconditions.

NXP and Freescale are trademarks of NXP B.V., Reg. U.S. Pat. & Tm. Off. All other product or service names are the property of their respective owners.

© 2008, 2009, 2015, 2017, 2018 NXP B.V. All rights reserved.

Document Number: MP3V5050

Rev. 1.4

12/2018

