

MP3H6115A, 15 to 115 kPa, Absolute, Integrated Pressure Sensor

Freescale's MP3H6115A series sensor integrates on-chip, bipolar op amp circuitry and thin film resistor networks to provide a high output signal and temperature compensation. The small form factor and high reliability of on-chip integration make the Freescale pressure sensor a logical and economical choice for the system designer.

The MP3H6115A series piezoresistive transducer is a state-of-the-art, monolithic, signal conditioned, silicon pressure sensor. This sensor combines advanced micromachining techniques, thin film metallization, and bipolar semiconductor processing to provide an accurate, high level analog output signal that is proportional to applied pressure.

Features

- Improved accuracy at high temperature
- Available in super small outline package
- 1.5% maximum error over 0 °C to 85 °C
- Ideally suited for microprocessor or microcontroller-based systems
- Temperature compensated from -40 °C to +125 °C
- Durable thermoplastic (PPS) surface mount package

Typical applications

- Aviation altimeters
- Industrial controls
- Engine control/manifold absolute pressure (MAP)
- Weather station and weather reporting device barometers

MP3H6115A

Super small outline package

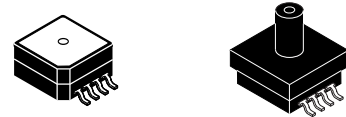

MP3H6115A6U/6T1
Case 98ARH99066A

MP3H6115AC6T1
Case 98ARH99089A

Top view

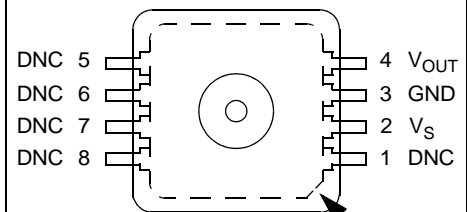

Pin 1 identification, chamfered corner.

Pinout

Ordering information									
Part number	Shipping	Package	# of Ports			Pressure type			Device marking
			None	Single	Dual	Gauge	Differential	Absolute	
Small Outline Package (MP3H6115A series)									
MP3H6115A6U	Rail	98ARH99066A	•					•	MP3H6115A
MP3H6115A6T1	Tape and Reel	98ARH99066A	•					•	MP3H6115A
MP3H6115AC6T1	Tape and Reel	98ARH99089A		•				•	MP3H6115A

Freescale reserves the right to change the detail specifications as may be required to permit improvements in the design of its products.

© 2006-2015 Freescale Semiconductor, Inc. All rights reserved.



Contents

1	General Description	3
1.1	Block diagram	3
1.2	Pinout	3
2	Mechanical and Electrical Specifications	4
2.1	Maximum ratings	4
2.2	Operating characteristics	4
3	On-chip Temperature Compensation and Calibration	5
4	Package Information	7
4.1	Minimum recommended footprint for surface mounted applications	7
4.2	Package Dimensions	8
5	Revision History	13

Related Documentation

The MP3H6115A device features and operations are described in a variety of reference manuals, user guides, and application notes. To find the most-current versions of these documents:

1. Go to the Freescale homepage at:
<http://www.freescale.com/>
2. In the Keyword search box at the top of the page, enter the device number MP3H6115A.
3. In the Refine Your Result pane on the left, click on the Documentation link.

MP3H6115A

1 General Description

1.1 Block diagram

Figure 1 shows a block diagram of the internal circuitry integrated on a pressure sensor chip.

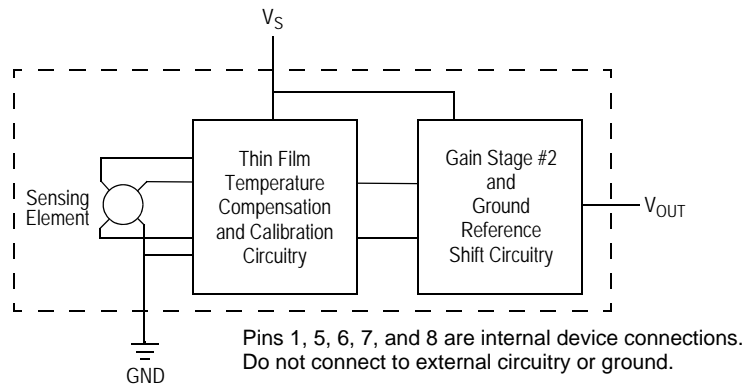

Figure 1. Integrated pressure sensor schematic

1.2 Pinout

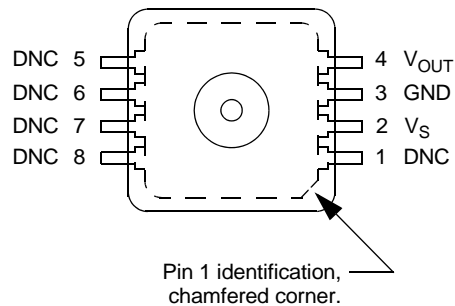

Figure 2. Device pinout (top view)

Table 1. Pin functions

Pin	Name	Function
1	DNC	Do not connect to external circuitry or ground. Pin 1 is notated by chamfered corner.
2	V_S	Voltage supply
3	GND	Ground
4	V_{OUT}	Output voltage
5	DNC	Do not connect to external circuitry or ground.
6	DNC	Do not connect to external circuitry or ground.
7	DNC	Do not connect to external circuitry or ground.
8	DNC	Do not connect to external circuitry or ground.

2 Mechanical and Electrical Specifications

2.1 Maximum ratings

Table 2. Maximum ratings⁽¹⁾

Parametrics	Symbol	Value	Units
Maximum pressure (P1 > P2)	P_{max}	400	kPa
Storage temperature	T_{stg}	-40 to +125	°C
Operating temperature	T_A	-40 to +125	°C
Output source current @ full-scale output ⁽²⁾	I_{o+}	0.5	mAdc
Output sink current @ minimum pressure offset ⁽²⁾	I_{o-}	-0.5	mAdc

1.Exposure beyond the specified limits may cause permanent damage or degradation to the device.

2.Maximum output current is controlled by effective impedance from V_{OUT} to GND or V_{OUT} to V_S in the application circuit.

2.2 Operating characteristics

Table 3. Operating characteristics ($V_S = 3.0$ Vdc, $T_A = 25$ °C unless otherwise noted, P1 > P2.)

Characteristic	Symbol	Min	Typ	Max	Unit
Pressure range	P_{OP}	15	—	115	kPa
Supply voltage ⁽¹⁾	V_S	2.7	3.0	3.3	Vdc
Supply current	I_o	—	4.0	8.0	mAdc
Minimum pressure offset ⁽²⁾ (0 to 85 °C) @ $V_S = 3.0$ Volts	V_{off}	0.079	0.12	0.161	Vdc
Full-scale output ⁽³⁾ (0 to 85 °C) @ $V_S = 3.0$ Volts	V_{FSO}	2.780	2.82	2.861	Vdc
Full-scale span ⁽⁴⁾ (0 to 85 °C) @ $V_S = 3.0$ Volts	V_{FSS}	2.660	2.70	2.741	Vdc
Accuracy (0 to 85 °C)	—	—	—	±1.5	% V_{FSS}
Sensitivity	V/P	—	27	—	mV/kPa
Response time ⁽⁵⁾	t_R	—	1.0	—	ms
Warm-up time ⁽⁶⁾	—	—	20	—	ms
Offset stability ⁽⁷⁾	—	—	±0.25	—	% V_{FSS}

1.Device is ratiometric within this specified excitation range.

2.Offset (V_{off}) is defined as the output voltage at the minimum rated pressure.

3.Full-scale output (V_{FSO}) is defined as the output voltage at the maximum or full-rated pressure.

4. Full-scale span (V_{FSS}) is defined as the algebraic difference between the output voltage at full-rated pressure and the output voltage at the minimum rated pressures

5.Response time is defined as the time for the incremental change in the output to go from 10% to 90% of its final value when subjected to a specified step change in pressure.

6.Warm-up time is defined as the time required for the product to meet the specified output voltage after the pressure has been stabilized.

7.Offset stability is the product's output deviation when subjected to 1000 cycles of pulsed pressure, temperature cycling with bias test.

3 On-chip Temperature Compensation and Calibration

Figure 3 illustrates the absolute sensing chip in the basic super small outline chip carrier (case 98ARH99066A).

Figure 4 shows a typical application circuit (output source current operation).

Figure 5 shows the sensor output signal relative to pressure input. Typical minimum and maximum output curves are shown for operation over 0 to 85 °C temperature range. The output will saturate outside of the rated pressure range.

A fluorosilicone gel isolates the die surface and wire bonds from the environment, while allowing the pressure signal to be transmitted to the silicon diaphragm. The MP3H6115A pressure sensor operating characteristics, internal reliability and qualification tests are based on use of dry air as the pressure media. Media other than dry air may have adverse effects on sensor performance and long-term reliability. Contact the factory for information regarding media compatibility in your application.

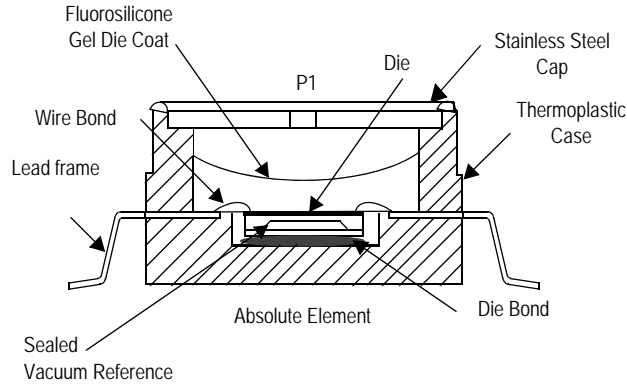

Figure 3. Cross-sectional diagram (not to scale)

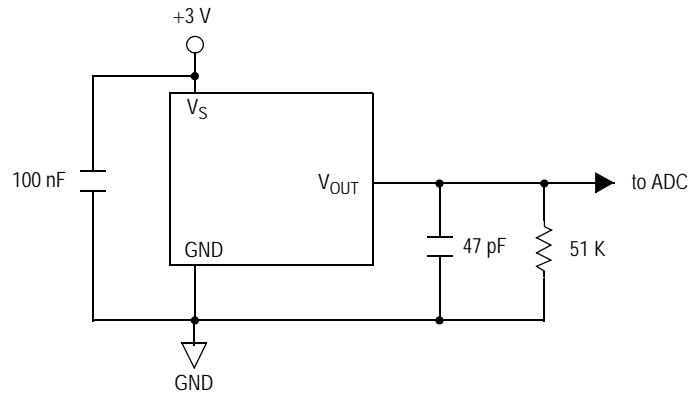

Figure 4. Recommended power supply decoupling and output filtering

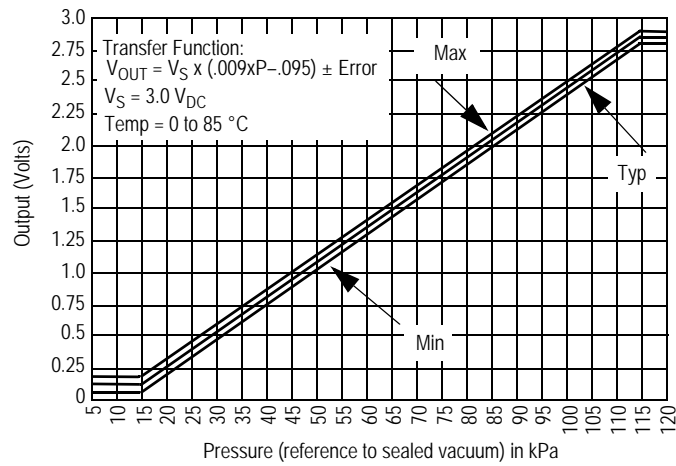
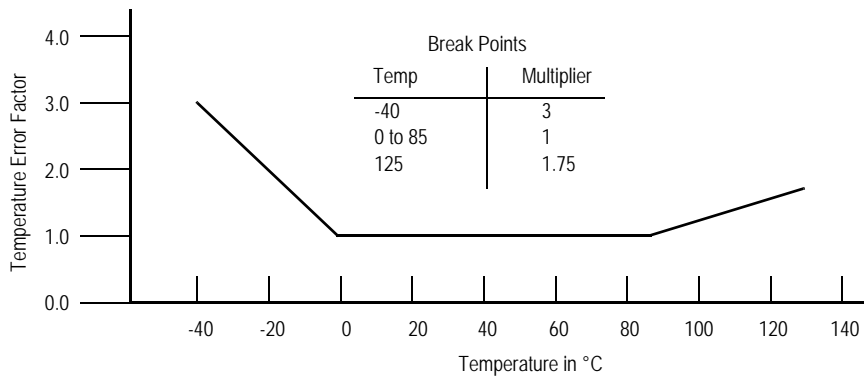

Figure 5. Output vs. absolute pressure

Normal Transfer Value: $V_{OUT} = V_S \times (0.009 \times P - 0.095)$
 $\pm (\text{Pressure Error} \times \text{Temp. Factor} \times 0.009 \times V_S)$
 $V_S = 3.0 \pm 0.3 V_{DC}$

Figure 6. Transfer function



NOTE: The temperature multiplier is a linear response from 0 °C to -40 °C and from 85 °C to 125 °C

Figure 7. Temperature error band

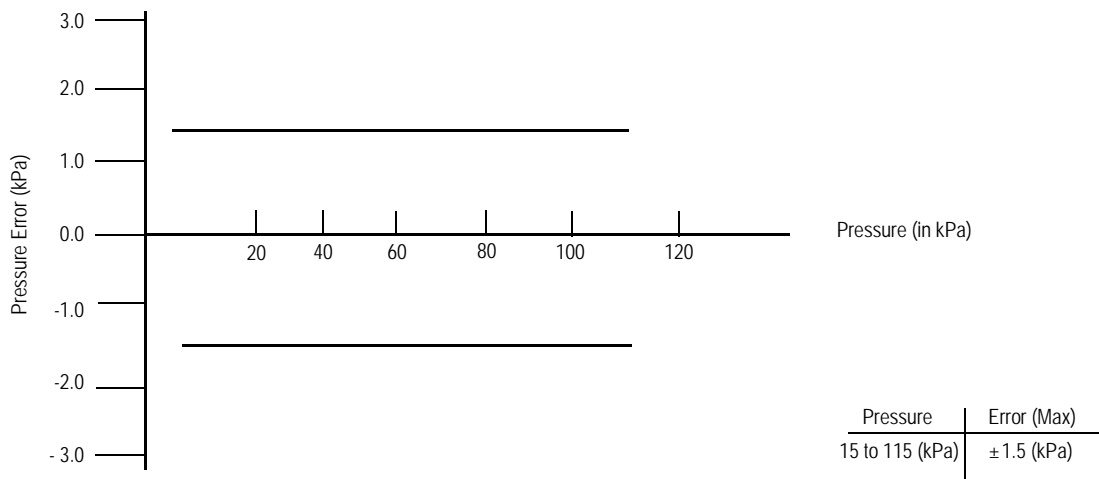

Figure 8. Pressure error band

4 Package Information

4.1 Minimum recommended footprint for surface mounted applications

Surface mount board layout is a critical portion of the total design. The footprint for the semiconductor package must be the correct size to ensure proper solder connection interface between the board and the package. With the correct pad geometry, the packages will self-align when subjected to a solder reflow process. It is always recommended to fabricate boards with a solder mask layer to avoid bridging and/or shorting between solder pads, especially on tight tolerances and/or tight layouts.



Figure 9. SSOP footprint

4.2 Package Dimensions

This drawing is located at http://cache.freescale.com/files/shared/doc/package_info/98ARH99066A.pdf.

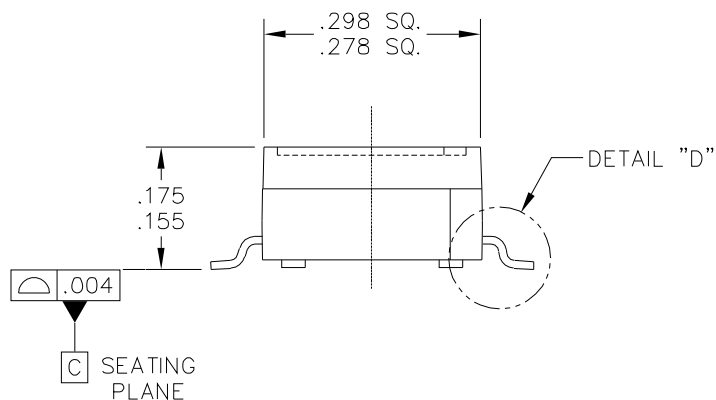
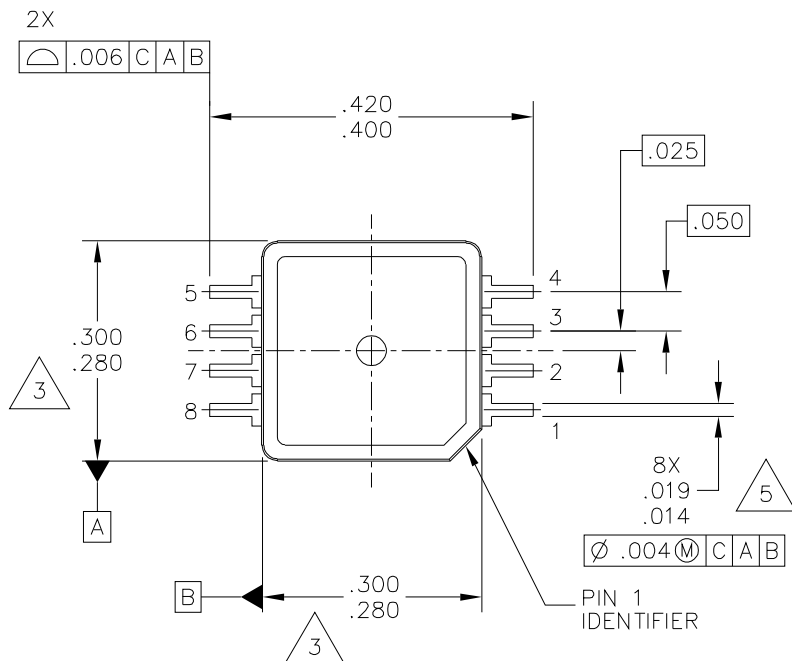

© FREESCALE SEMICONDUCTOR, INC. ALL RIGHTS RESERVED.		MECHANICAL OUTLINE		PRINT VERSION NOT TO SCALE	
TITLE: 8 LEAD SSOP		DOCUMENT NO: 98ARH99066A		REV: H	
		CASE NUMBER: 1317-04		13 APR 2012	
		STANDARD: NON-JEDEC			

Case 98ARH99066A, small outline package, surface mount

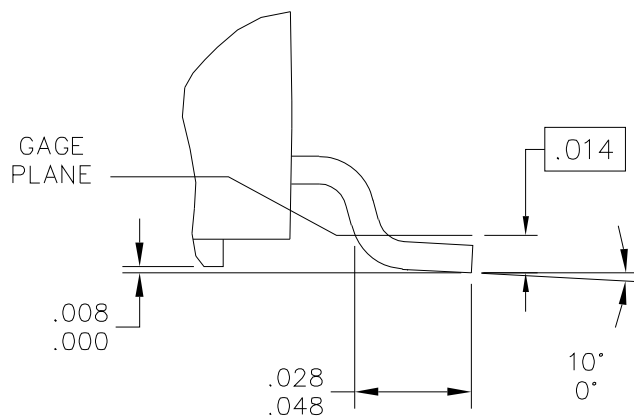

DETAIL "D"

© FREESCALE SEMICONDUCTOR, INC. ALL RIGHTS RESERVED.	MECHANICAL OUTLINE	PRINT VERSION NOT TO SCALE	
TITLE: 8 LEAD SSOP	DOCUMENT NO: 98ARH99066A	REV: H	
	CASE NUMBER: 1317-04	13 APR 2012	
	STANDARD: NON-JEDEC		

Case 98ARH99066A, small outline package, surface mount



NOTES:

1. ALL DIMENSIONS IN INCHES.
2. DIMENSIONING AND TOLERANCING PER ASME Y14.5M-1994.
3. DIMENSIONS DO NOT INCLUDE MOLD FLASH OR PROTRUSIONS.
MOLD FLASH OR PROTRUSION SHALL NOT EXCEED .006 INCHES PER SIDE.
4. ALL VERTICAL SURFACES TO BE 5° MAXIMUM.
5. DIMENSION DOES NOT INCLUDE DAMBAR PROTRUSION.
ALLOWABLE DAMBAR PROTRUSION SHALL BE .008 INCHES MAXIMUM.

© FREESCALE SEMICONDUCTOR, INC. ALL RIGHTS RESERVED.	MECHANICAL OUTLINE	PRINT VERSION NOT TO SCALE	
TITLE: 8 LEAD SSOP	DOCUMENT NO: 98ARH99066A	REV: H	
	CASE NUMBER: 1317-04	13 APR 2012	
	STANDARD: NON-JEDEC		

Case 98ARH99066A, small outline package, surface mount

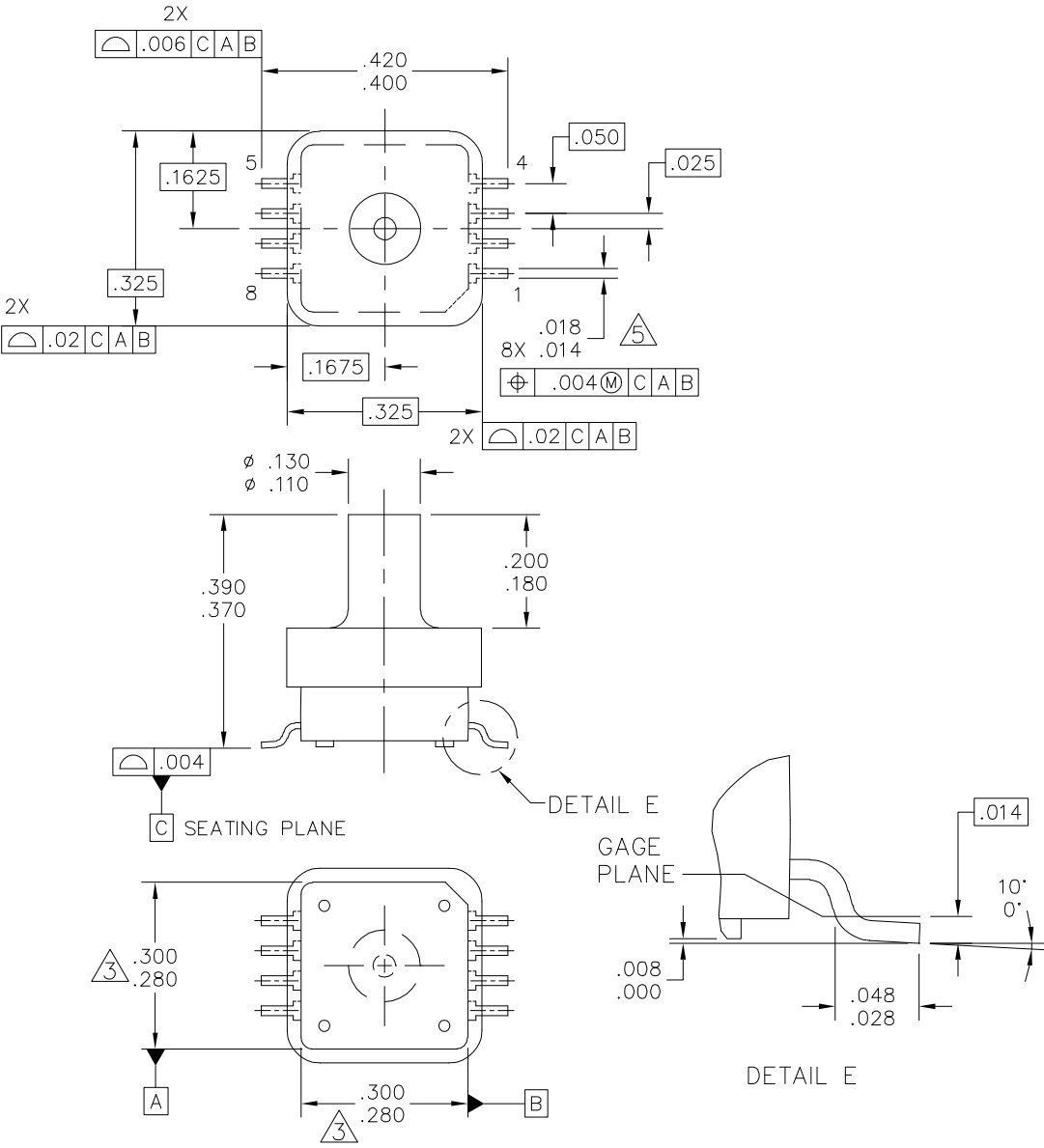

© FREESCALE SEMICONDUCTOR, INC. ALL RIGHTS RESERVED.	MECHANICAL OUTLINE	PRINT VERSION NOT TO SCALE
TITLE: 8 LD, PORTED SSOP		DOCUMENT NO: 98ARH99089A REV: G
		STANDARD: NON-JEDEC
		09 NOV 2012

Case 98ARH99089A, small outline package, surface mount



NOTES:

1. ALL DIMENSIONS IN INCHES.
2. DIMENSIONING AND TOLERANCING PER ASME Y14.5M-1994.
3. DIMENSIONS DO NOT INCLUDE MOLD FLASH OR PROTRUSIONS.
MOLD FLASH OR PROTRUSION SHALL NOT EXCEED .006 INCHES PER SIDE.
4. ALL VERTICAL SURFACES TO BE 5° MAXIMUM.
5. DIMENSION DOES NOT INCLUDE DAMBAR PROTRUSION.
ALLOWABLE DAMBAR PROTRUSION SHALL BE .008 INCHES MAXIMUM.

© FREESCALE SEMICONDUCTOR, INC. ALL RIGHTS RESERVED.	MECHANICAL OUTLINE	PRINT VERSION NOT TO SCALE
TITLE: 8 LD, PORTED SSOP	DOCUMENT NO: 98ARH99089A	REV: G
	STANDARD: NON-JEDEC	
		09 NOV 2012

Case 98ARH99089A, small outline package, surface mount

5 Revision History

Table 4. Revision history

Revision number	Revision date	Description
5.1	05/2012	<ul style="list-style-type: none"> Updated Package Drawing 98ARH99066A was Rev. F, updated to Rev. H.
6	02/2014	<ul style="list-style-type: none"> Removed non-ported part numbers, MP3H6115A6U and MP3H6115A6T1 and any references to the device. Removed package outline. Updated Package Drawing 98ARH99089A was Rev. D, updated to Rev. G.
6.1	06/2015	<ul style="list-style-type: none"> Added non-ported option back into document. Updated format.



How to Reach Us:

Home Page:

freescale.com

Web Support:

freescale.com/support

Information in this document is provided solely to enable system and software implementers to use Freescale products. There are no express or implied copyright licenses granted hereunder to design or fabricate any integrated circuits based on the information in this document.

Freescale reserves the right to make changes without further notice to any products herein. Freescale makes no warranty, representation, or guarantee regarding the suitability of its products for any particular purpose, nor does Freescale assume any liability arising out of the application or use of any product or circuit, and specifically disclaims any and all liability, including without limitation consequential or incidental damages. "Typical" parameters that may be provided in Freescale data sheets and/or specifications can and do vary in different applications, and actual performance may vary over time. All operating parameters, including "typicals," must be validated for each customer application by customer's technical experts. Freescale does not convey any license under its patent rights nor the rights of others. Freescale sells products pursuant to standard terms and conditions of sale, which can be found at the following address: freescale.com/salestermsandconditions.

Freescale and the Freescale logo are trademarks of Freescale Semiconductor, Inc., Reg. U.S. Pat. & Tm. Off. All other product or service names are the property of their respective owners.

© 2006-2015 Freescale Semiconductor, Inc.

Document Number: MP3H6115A

Rev. 6.1

06/2015

