

PNP EPITAXIAL SILICON TRANSISTOR

HIGH VOLTGE TRANDIDTOR

- Complement to MMBTA42LT1
- High Collector-Emitter Voltage: $V_{cbo} = -300V$
- Collector current: $I_c = -500mA$
- Collector Dissipation: $P_c = 225mW (T_a = 25^\circ C)$

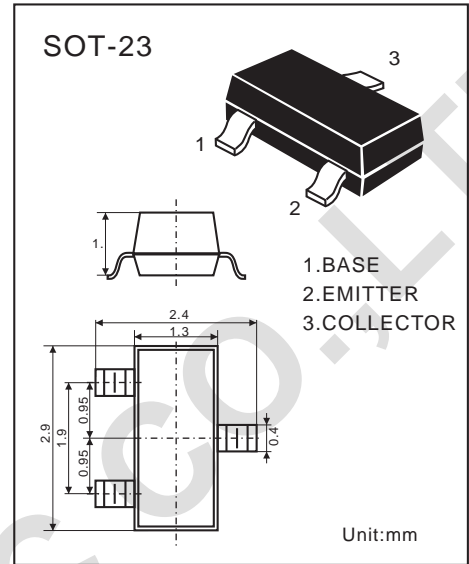

ABSOLUTE MAXIMUM RATINGS

($T_a = 25^\circ C$)

Characteristic	Symbol	Rating	Unit
Collector-Base Voltage	V_{CBO}	-300	V
Collector-Emitter Voltage	V_{CEO}	-300	V
Emitter-Base Voltage	V_{EBO}	-5	V
Collector Current	I_C	-500	mA
Collector Dissipation $T_a = 25^\circ C^*$	P_D	225	mW
Junction Temperature	T_j	150	$^\circ C$
Storage Temperature	T_{stg}	-55~150	$^\circ C$

Electrical Characteristics

($T_a = 25^\circ C$)

Characteristic	Symbol	MIN.	TYP.	MAX.	Unit	Condition
Collector-Base Breakdown Voltage	BV_{CBO}	-300			V	$I_C = -100\mu A, I_E = 0$
Collector-Emitter Breakdown Voltage#	BV_{CEO}	-300			V	$I_C = -1mA, I_B = 0$
Emitter-Base Breakdown Voltage	BV_{EBO}	-5			V	$I_E = -100\mu A, I_C = 0$
Collector Cutoff Current	I_{CBO}			-250	nA	$V_{CB} = -200V, V_e = 0$
Collector Cutoff Current	I_{EBO}			-100	nA	$V_{CB} = -3V, I_C = 0$
DC Current Gain	H_{FE}	40		250		$V_{CE} = -10V, I_C = -10mA$
Collector-Emitter Saturation Voltage	$V_{CE(sat)}$			-0.5	V	$I_C = -20mA, I_B = -2mA$
Base-Emitter On Voltage	$V_{BE(sat)}$			-0.9	V	$I_C = -20mA, I_B = -2mA$
Collector-Base Capacitance	C_{ob}			6	PF	$V_{CB} = -20V, I_E = 0, f = 100MHz$
Current Gain-Bandwidth Product	f_T	50	100		MHZ	$V_{CE} = -20V, I_C = -10mA, f = 100MHz$

*Total Device Dissipation: $FR = 1X0.75X0.062$ in Board Derate $25^\circ C$

#Pulse Test: Pulse Width $\leq 300\mu S$ Duty cycle $\leq 2\%$

DEVICE MARKING:

MMBTA92LT1=2D

Typical Characteristics

