

NPN EPITAXIAL SILICON TRANSISTOR

**2W OUTPUT AMPLIFIER OF PORTABLE
RADIO IN CLASS
B PUSH-PULL OPERATION**

- Complement to MMPT8550LT1
- Collector Current: $I_C=500\text{mA}$
- Collector Dissipation: $P_C=225\text{mW}(T_C=25^\circ\text{C})$

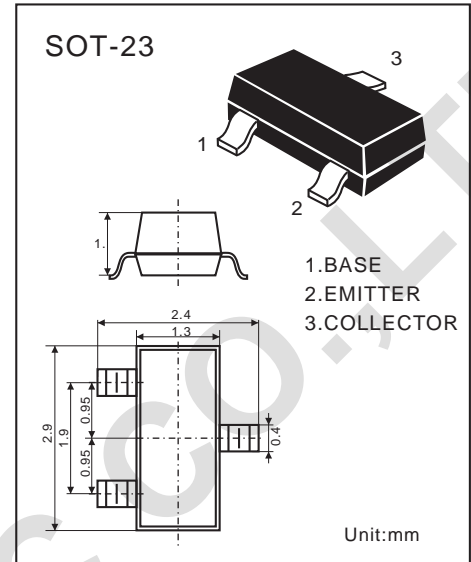

ABSOLUTE MAXIMUM RATINGS

($T_a=25^\circ\text{C}$)

Characteristic	Symbol	Rating	Unit
Collector-Base Voltage	V_{CB0}	40	V
Collector-Emitter Voltage	V_{CE0}	25	V
Emitter-Base Voltage	V_{EB0}	6	V
Collector Current	I_C	500	mA
Collector Dissipation $T_a=25^\circ\text{C}^*$	P_D	225	mW
Junction Temperature	T_j	150	$^\circ\text{C}$
Storage Temperature	T_{stg}	-55-150	$^\circ\text{C}$

Electrical Characteristics

($T_a=25^\circ\text{C}$)

Characteristic	Symbol	MIN.	TYP.	MAX.	Unit	Test Conditions
Collector-Base Breakdown Voltage	BV_{CB0}	40			V	$I_C=100\mu\text{A}$ $I_E=0$
Collector-Emitter Breakdown Voltage#	BV_{CE0}	25			V	$I_C=1\text{mA}$ $I_B=0$
Emitter-Base Breakdown Voltage	BV_{EB0}	6			V	$I_E=100\mu\text{A}$ $I_C=0$
Collector Cutoff Current	I_{CBO}			100	nA	$V_{CB}=35\text{V}$, $I_E=0$
Emitter Cutoff Current	I_{EBO}			100	nA	$V_{EB}=6\text{V}$, $I_C=0$
DC Current Gain	h_{FE1}	45				$V_{CE}=1\text{V}$, $I_C=5\text{mA}$
DC Current Gain	h_{FE2}	85	160	300		$V_{CE}=1\text{V}$, $I_C=50\text{mA}$
DC Current Gain	h_{FE3}	30				$V_{CE}=1\text{V}$, $I_C=500\text{mA}$
Collector-Emitter Saturation Voltage	$V_{CE(sat)}$		0.28	0.5	V	$I_C=500\text{mA}$, $I_B=50\text{mA}$
Base-Emitter Saturation Voltage	$V_{BE(sat)}$		0.98	1.2	V	$I_C=500\text{mA}$, $I_B=50\text{mA}$
Base-Emitter Voltage	V_{BE}		0.66	1	V	$I_{CE}=1\text{V}$, $I_C=10\text{mA}$
Output Capacitance	C_{ob}		9		PF	$V_{CB}=10\text{V}$, $I_E=0$, $f=1\text{MHz}$
Current Gain-Bandwidth Product	f_T	100	190		MHZ	$V_{CE}=10\text{V}$, $I_C=50\text{mA}$

*Total Device Dissipation:FR=1X0.75X0.062 in Board ,Derate 25°C

#Pulse Test: Pulse Width $\leq 300\mu\text{S}$,Duty cycle $\leq 2\%$

MMBT8050LT1=A6

Typical Characteristics

