

General Description

The MICRF112 is a high-performance, easy to use, true “Data-In, RF-Out,” ASK/FSK, phase-locked loop (PLL) based, transmitter IC for applications in the 300MHz to 450MHz frequency range. These applications include remote keyless entry (RKE) and tire pressure monitoring (TPMS). The device needs only a low-cost crystal to precisely set the desired RF frequency, and a few external components for matching the power amplifier output to the antenna.

The MICRF112 operates over the 1.8V to 3.6V operating range and delivers +10dBm (CW) output power into a 50Ω load, while consuming 11.5mA of supply current from a 3.0V power supply. In ASK mode, the device consumes 6.9mA of supply current at a data rate of 1kbps (Manchester 50%). It features a low-power shutdown mode in which the device typically consumes 50nA of supply current. This makes it an ideal solution for battery powered applications.

The MICRF112 is rated for the -40°C to +125°C temperature range, and is available in 10-pin MSOP and 10-pin Ultra-Thin DFN packages. For automotive applications, where AEC-Q100 qualification is required, consider the MAQRF112. For ASK-only applications that do not require shutdown, consider the MICRF113 in SOT23-6.

Datasheets and support documentation can be found on Micrel’s website at: www.micrel.com.

Features

- 1.8V to 3.6V supply voltage range
- Up to +10dBm output power (CW)
- 6.9mA supply current at 1kbps ASK (50% Manchester)
- 11.5mA supply current at +10dBm (FSK/CW)
- 1μA shutdown supply current
- Data rates up to 50kbps ASK, 10kbps FSK
- Crystal or ceramic resonators sets RF frequency
- -40°C to +125°C temperature range
- 10-pin MSOP (3.0mm x 4.9mm)
- 10-pin Ultra-Thin DFN (2mm x 2mm x 0.4mm)

Applications

- Remote keyless entry systems (RKE)
- Remote control (STB, HVAC, and appliances)
- Garage door openers (GDO)
- Tire pressure monitor systems (TPMS)
- Outdoor weather stations
- Security/Alarm systems
- Lighting and fan remote controls
- Doorbells
- Irrigation control

Typical Application

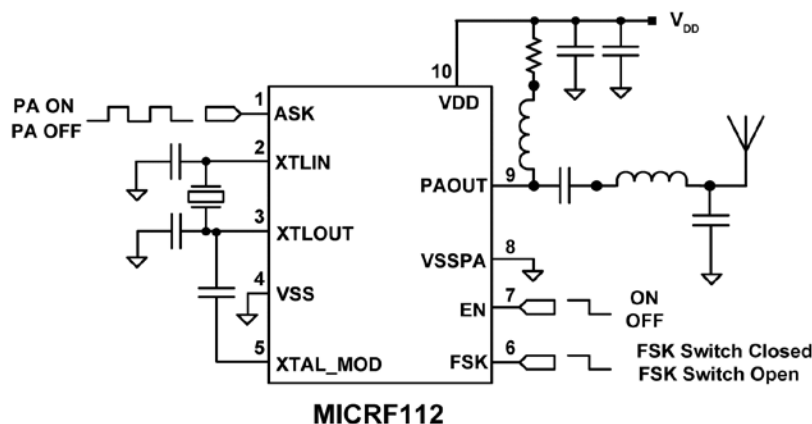

Ordering Information

Part Number	Top Mark	Temp. Range	Package
MICRF112YMM	RF112YMM	-40°C to +125°C	10-Pin MSOP
MICRF112YMU	12B	-40°C to +125°C	10-Pin UTDFN

Pin Configuration

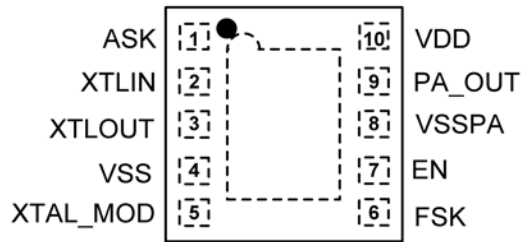

10-Pin Ultra-Thin DFN (MU)
(2mm x 2mm x 0.4mm)
Top View

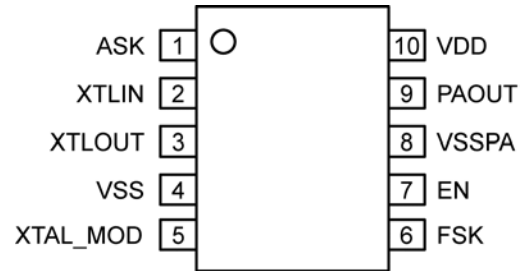

10-Pin MSOP (MM)
Top View

Note: The Pin1 marking symbol could be a circle, triangle, or other symbol.

Pin Description

Pin Number	Pin Name	Pin Function
1	ASK	ASK Data input
2	XTLIN	Reference oscillator input connection
3	XTLOUT	Reference oscillator output connection
4	VSS	Ground
5	XTAL_MOD	Reference oscillation modulation port for FSK operation
6	FSK	FSK Data input
7	EN	Chip enable, active high
8	VSSPA	PA ground
9	PAOUT	PA output
10	VDD	Positive power supply

Absolute Maximum Ratings⁽¹⁾

Supply Voltage (VDD)	+4.3V
Voltage on PAOUT	+7.2V
Voltage on I/O Pins	VSS – 0.3 to VDD + 0.3
Lead Temperature (soldering, 10s).....	+300°C
Storage Temperature (T _S).....	–65°C to +150°C
ESD Rating.....	Note 3

Operating Ratings⁽²⁾

Supply Voltage (VDD)	1.8V to 3.6V
Ambient Operating Temperature (T _A)	–40°C to +125°C
Transmitter Frequency Range	300MHz to 450MHz

Electrical Characteristics⁽⁴⁾

Specifications apply for VDD = 3.0V, T_A = 25°C, Freq_{REFOSC} = 13.560MHz, EN = VDD. 1Kbps data rate, 50% duty cycle. R_L 50Ω load (matched)

Parameter	Condition	Min.	Typ.	Max.	Units
Power Supply					
Standby Supply Current, I _q	EN = V _{SS}		0.05	1	μA
Mark Supply Current I _{ON}	@ 315MHz, P _{OUT} = +10dBm		11.5		mA
	@ 433.92MHz, P _{OUT} = +10dBm		11.6		mA
SPACE Supply Current, I _{OFF}	@ 315MHz		2.4		mA
	@ 433.92MHz		2.7		mA
RF Output Section and Modulation Limits:					
Output Power Level, P _{OUT} FSK or ASK "Mark"	@ 315MHz ⁽⁴⁾		10		dBm
	@ 433.92MHz ⁽⁴⁾		10		dBm
Harmonics output for 315MHz	@ 630MHz ⁽⁴⁾ 2nd harm.		–53		dBc
	@ 945MHz ⁽⁴⁾ 3rd harm.		–53		dBc
Harmonics Output for 433.92MHz	@ 867.84MHz ⁽⁴⁾ 2nd harm.		–51		dBc
	@ 1301.76MHz ⁽⁴⁾ 3rd harm.		–65		dBc
Extinction Ratio for ASK			80		dBc
FSK Modulation					
Frequency Deviation	Load capacitor = 10pF, crystal type = HC49/U		22		kHz
Data Rate				10	Kbps
ASK Modulation					
Data Rate				50	Kbps
Occupied Bandwidth	@ 315MHz ⁽⁵⁾		<700		kHz
	@ 433.92MHz ⁽⁵⁾		<1000		kHz
VCO Section					
315MHz Single Side Band Phase Noise	@ 100kHz from Carrier		–76		dBc/Hz
	@ 1000kHz from Carrier		–79		dBc/Hz
433.92MHz Single Side Band Phase Noise	@ 100kHz from Carrier		–72		dBc/Hz
	@ 1000kHz from Carrier		–81		dBc/Hz
Reference Oscillator Section					
XTLIN, XTLOUT, XTLMOD	Pin capacitance		2		pF
External Capacitance	See Schematic C17 & C18		18		pF
Oscillator Start-Up Time ⁽⁶⁾	Crystal: HC49S		400		μs

Parameter	Condition	Min.	Typ.	Max.	Units
Digital/Control Section					
Output Blanking	STDBY transition from low to high		500		μs
Digital Input (EN, ASK, and FSK)	High (V_{IH})	$0.8 \times V_{DD}$			V
	Low (V_{IL})			$0.2 \times V_{DD}$	V
Digital Input Leakage Current (EN, ASK, and FSK Pins)	High (V_{IH})		0.05		μA
	Low (V_{IL})		0.05		μA
Undervoltage Lock Out (UVLO)			1.6		V

Notes:

1. Exceeding the absolute maximum rating may damage the device.
2. The device is not guaranteed to function outside its operating ratings.
3. Devices are ESD sensitive. Handling precautions recommended. Human body model, 1.5k in series with 100pF.
4. Measured using the circuit shown in the "Test Circuit" section.
5. RBW = 100kHz, OBW measured at -20dBc.
6. Dependent on crystal.

Test Circuit

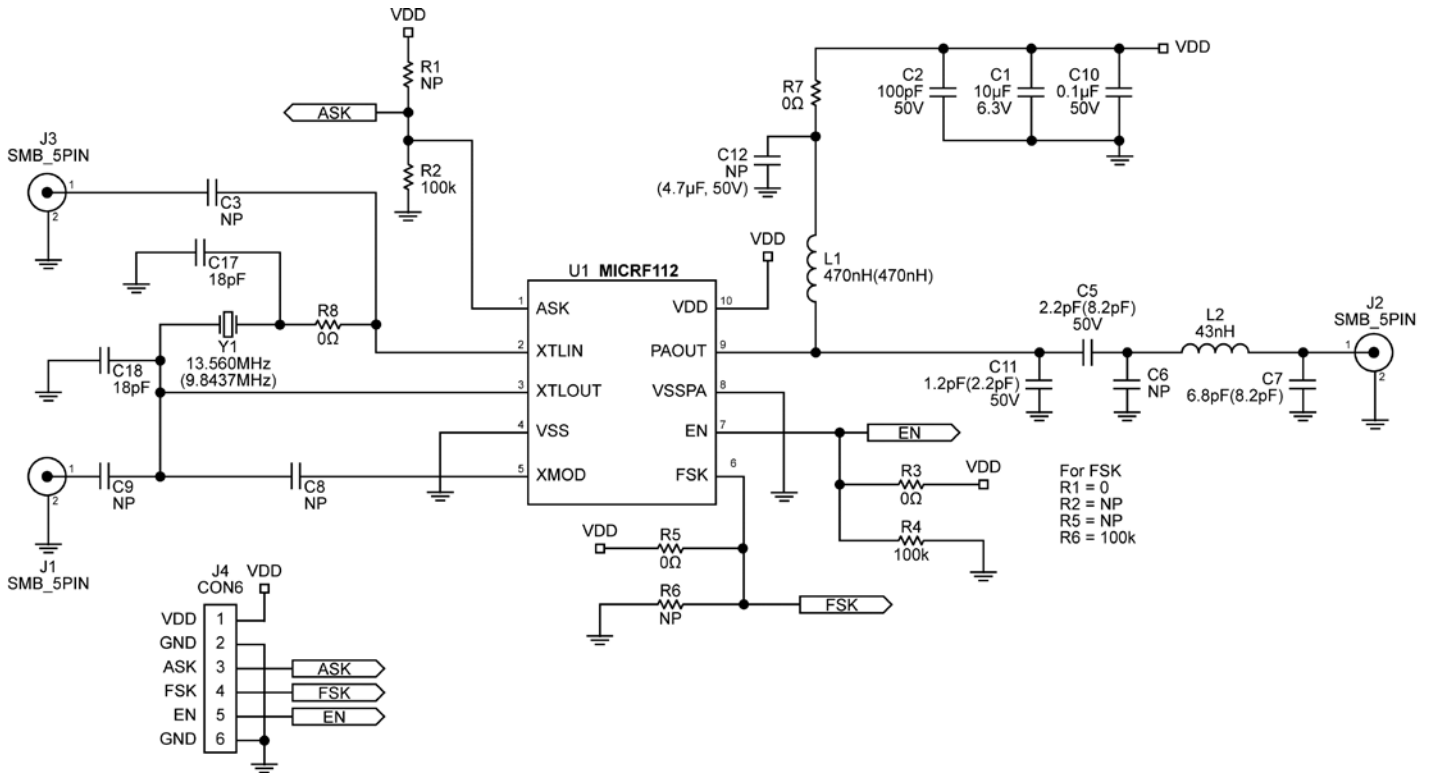

MICRF112 Test Circuit with 50Ω Output (MSOP)

Notes:

1. Values without parenthesis are for 433.92MHz and values in parenthesis are for 315MHz.
2. C9 = 100pF for external REF-OSC.
3. For FSK R1 = 0Ω, R2 = NP, R6 = 100k, and R5 = NP.

50Ω Evaluation Board PCB Layout

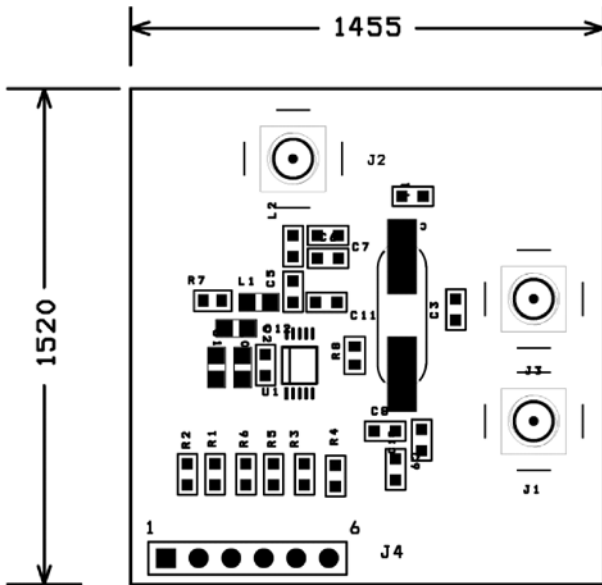

Assembly Drawing
MICRF112 50Ω Evaluation Board (MSOP)

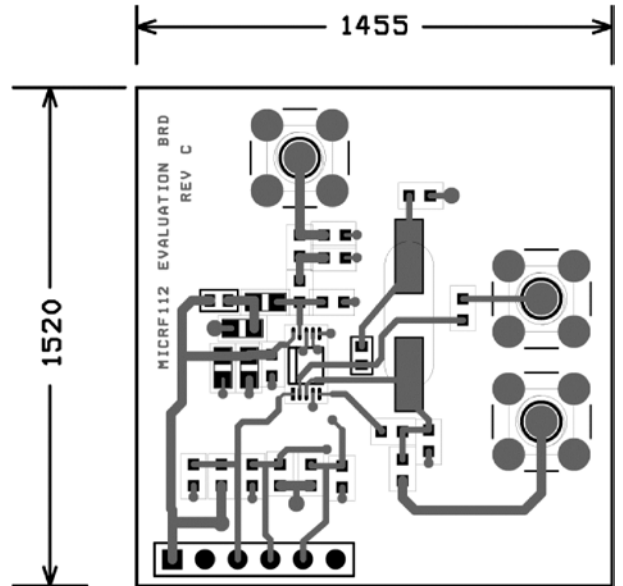

Top Layer
MICRF112 50Ω Evaluation Board (MSOP)

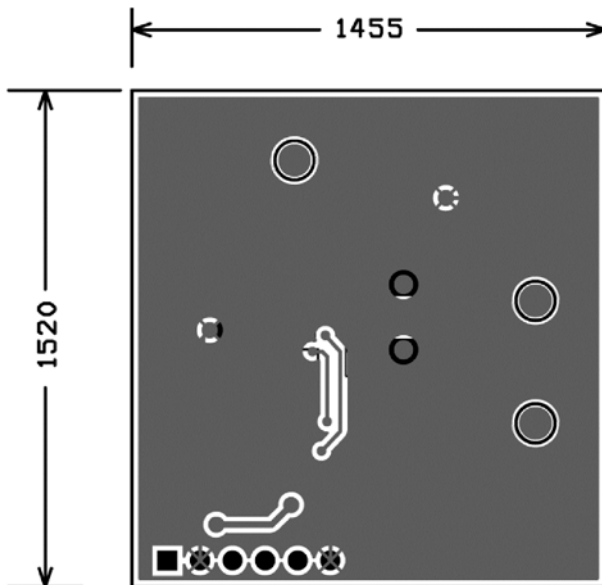

Bottom Layer
MICRF112 50Ω Evaluation Board (MSOP)

Typical Characteristics Using MICRF112, 50Ω Evaluation Board (MSOP)

315MHz OBW, ASK = 1kHz

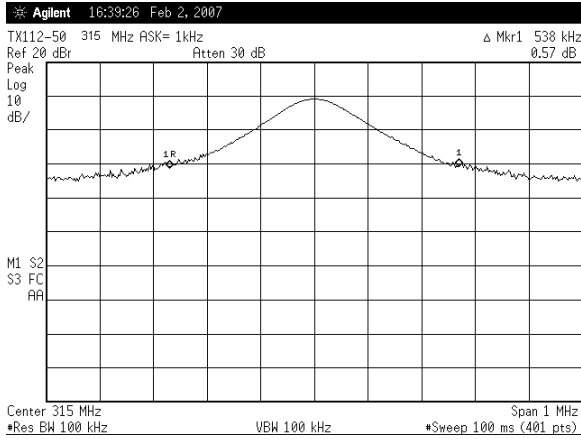

315MHz OBW, ASK = 50kHz

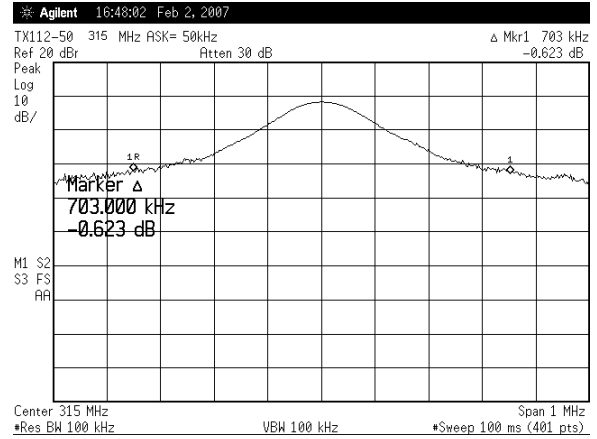

CW Max Power @ 3V, 315MHz, ASK = 1kHz⁽¹⁾

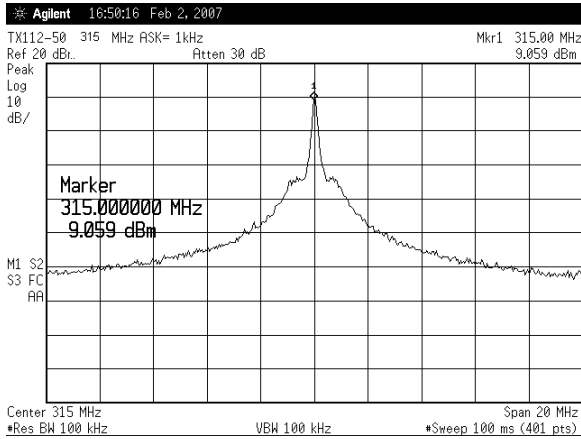

RF Spectrum 2nd Harmonic; Fundamental at 315MHz

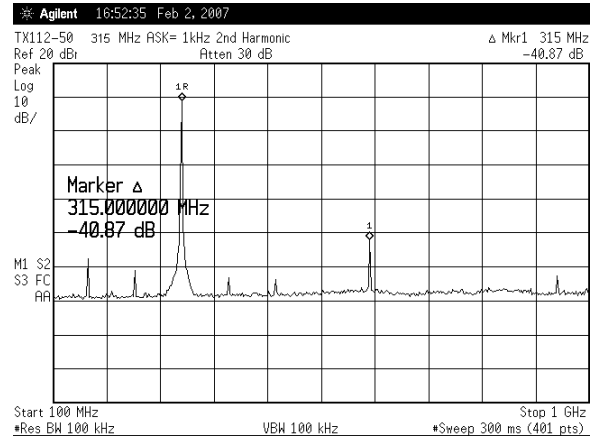

RF Spectrum 3rd Harmonic; Fundamental at 315MHz

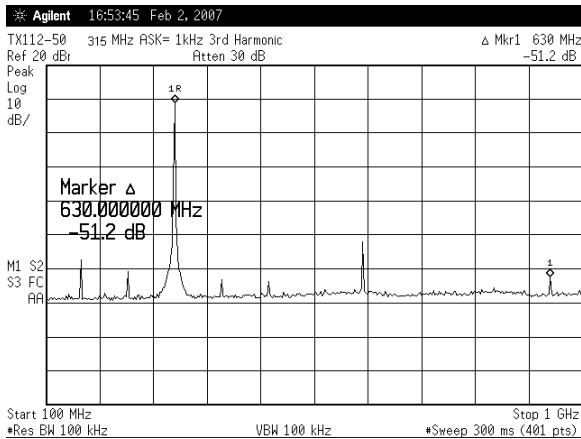

315MHz, Power Level at Space, VDD = 3.0V, ASK = 1kHz



Note:

1. 1.2dB cable loss.

Typical Characteristics Using MICRF112, 50Ω Evaluation Board (MSOP) (Continued)

315MHz, Zero Span, ASK = 1kHz

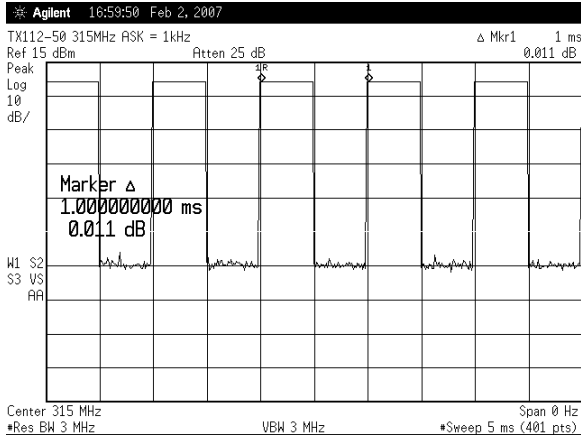

315MHz, Zero Span, ASK = 50kHz

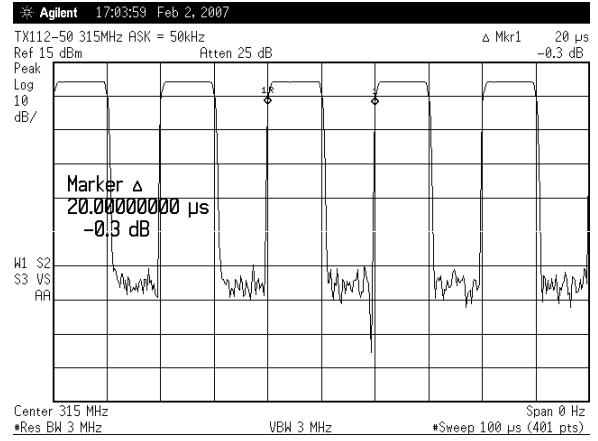

315MHz, Phase Noise, ASK = 1kHz, 100kHz Offset, -75.59dBc/Hz

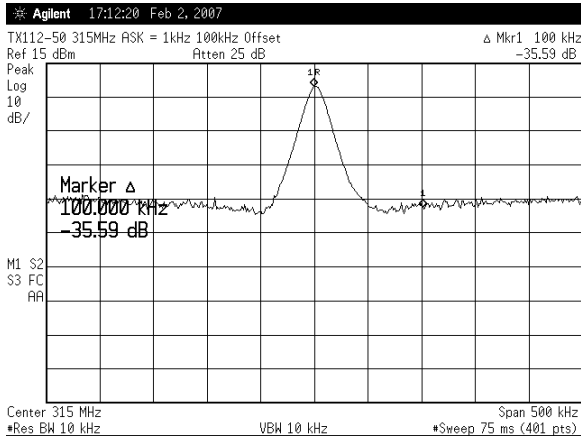

315MHz, Phase Noise, ASK = 1kHz, 1MHz Offset, -78.99dBc/Hz

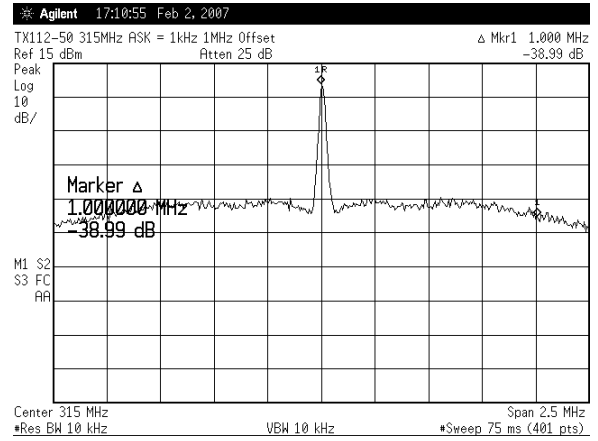

315MHz, Phase Noise, ASK = CW, 100kHz Offset, -74.39dBc/Hz

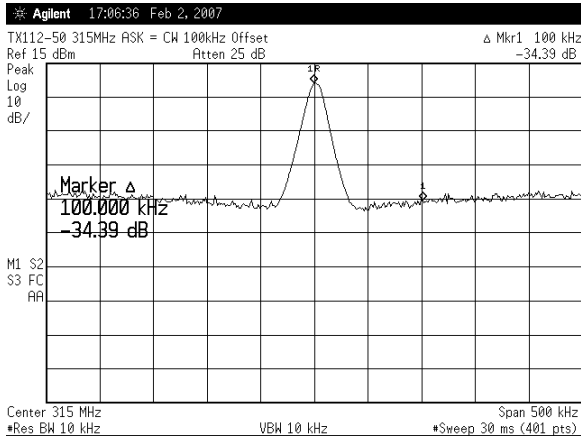

315MHz, Phase Noise, ASK = CW, 1MHz Offset, -77.28dBc/Hz

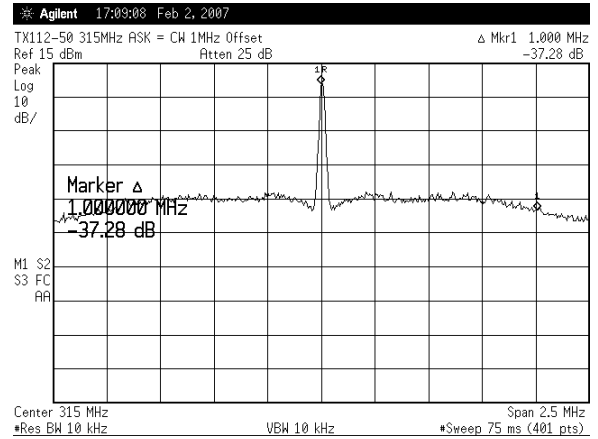

Typical Characteristics Using MICRF112, 50Ω Evaluation Board (MSOP) (Continued)

433.92MHz OBW, ASK = 1kHz

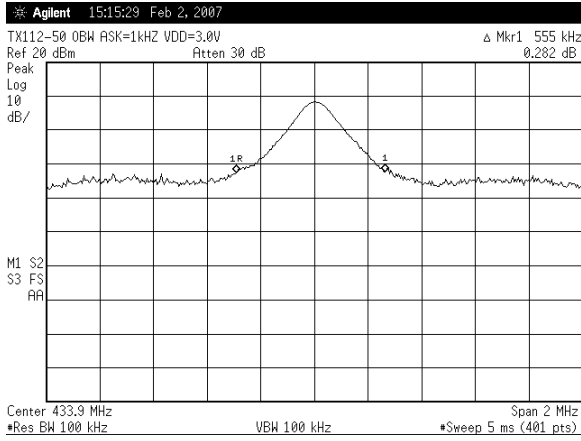

433.92MHz OBW, ASK = 50kHz

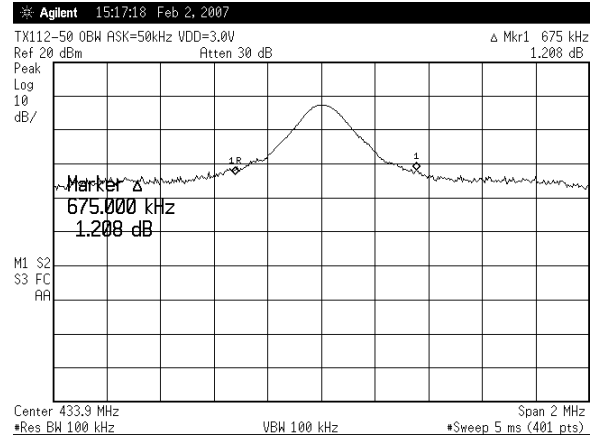

433.92MHz, CW Max Power @ 3V, ASK = 1kHz⁽¹⁾

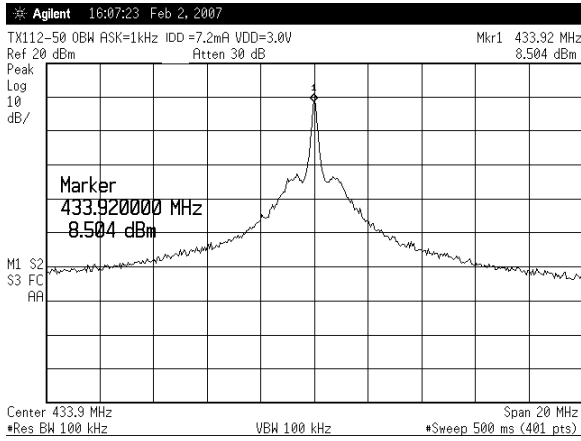

RF Spectrum 2nd Harmonic; Fundamental at 433.92MHz

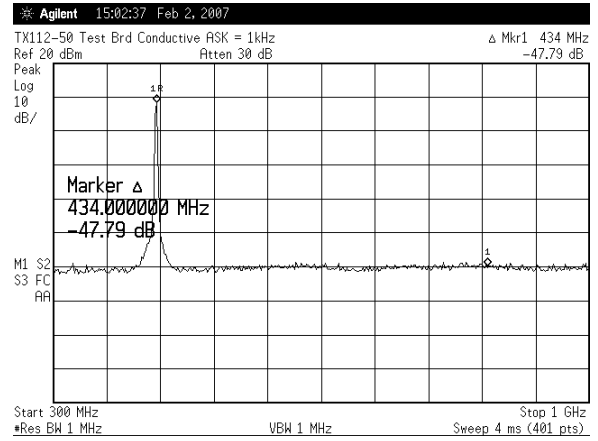

RF Spectrum 3rd Harmonic; Fundamental at 433.92MHz

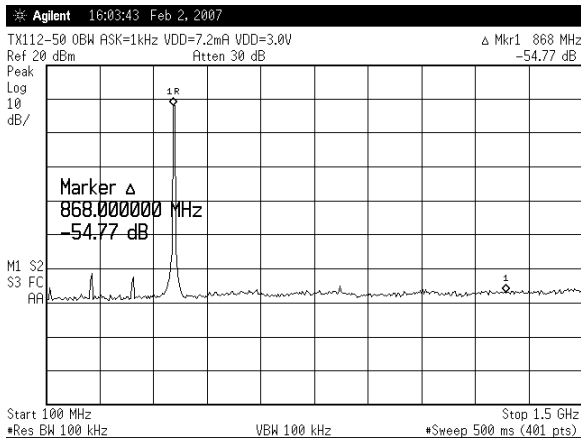

433.92MHz, Power Level at Space, VDD = 3.0V, ASK = 1kHz

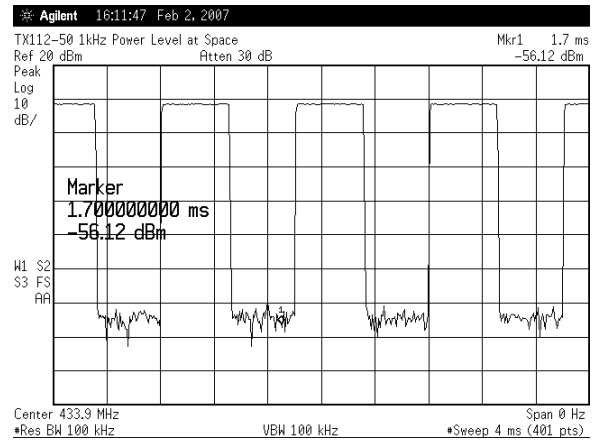

Note:

1. 1.3dB cable loss.

Typical Characteristics Using MICRF112, 50Ω Evaluation Board (MSOP) (Continued)

433.92MHz Zero Span, 1kHz

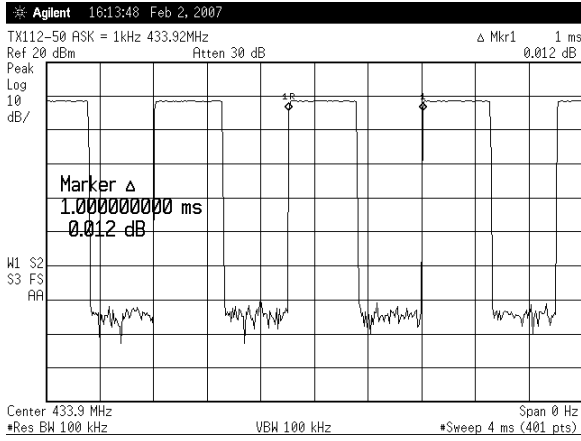

433.92ASK Zero Span at 50kHz

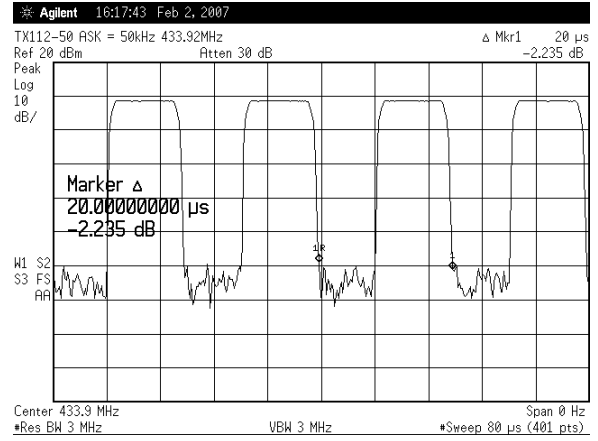

433.92MHz Phase Noise, ASK = CW, 100kHz Offset, -81.04dBc/Hz

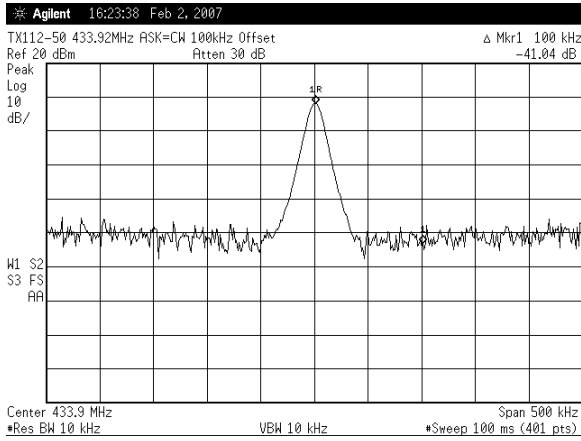

433.92MHz Phase Noise, ASK = CW, 1MHz Offset, -78.76dBc/Hz

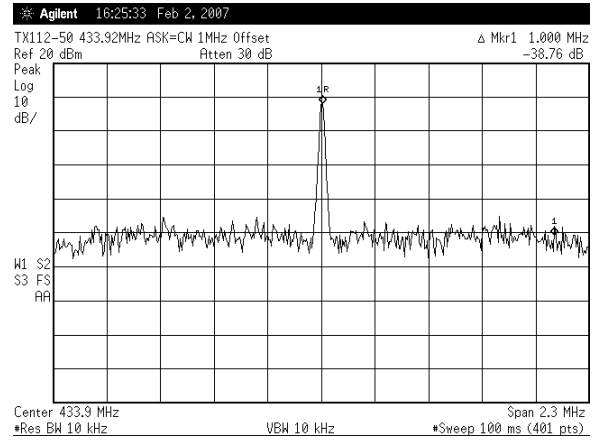

433.92MHz Phase Noise, ASK = 1kHz, 100kHz Offset, -71.73dBc/Hz

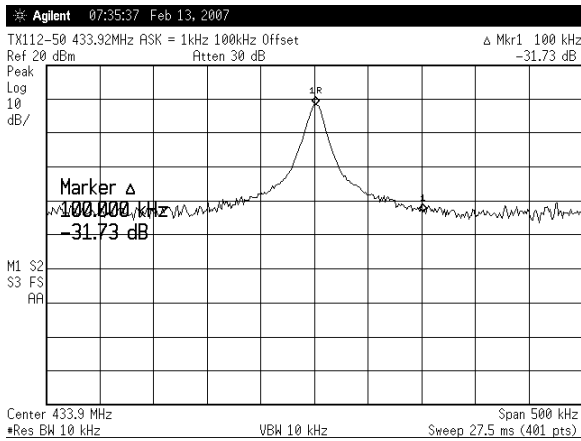

433.92MHz Phase Noise, ASK = 1kHz, 1MHz Offset, -81.04dBc/H

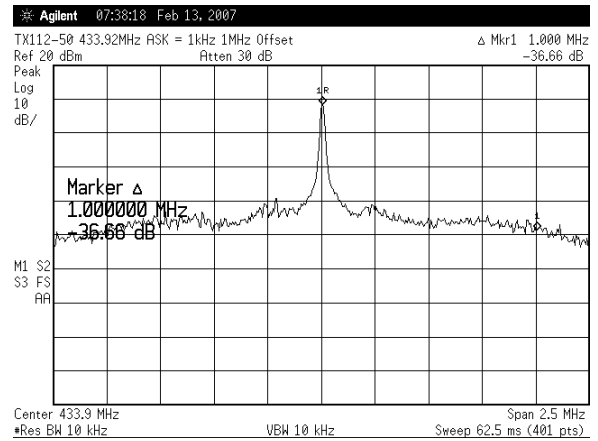

Functional Diagram

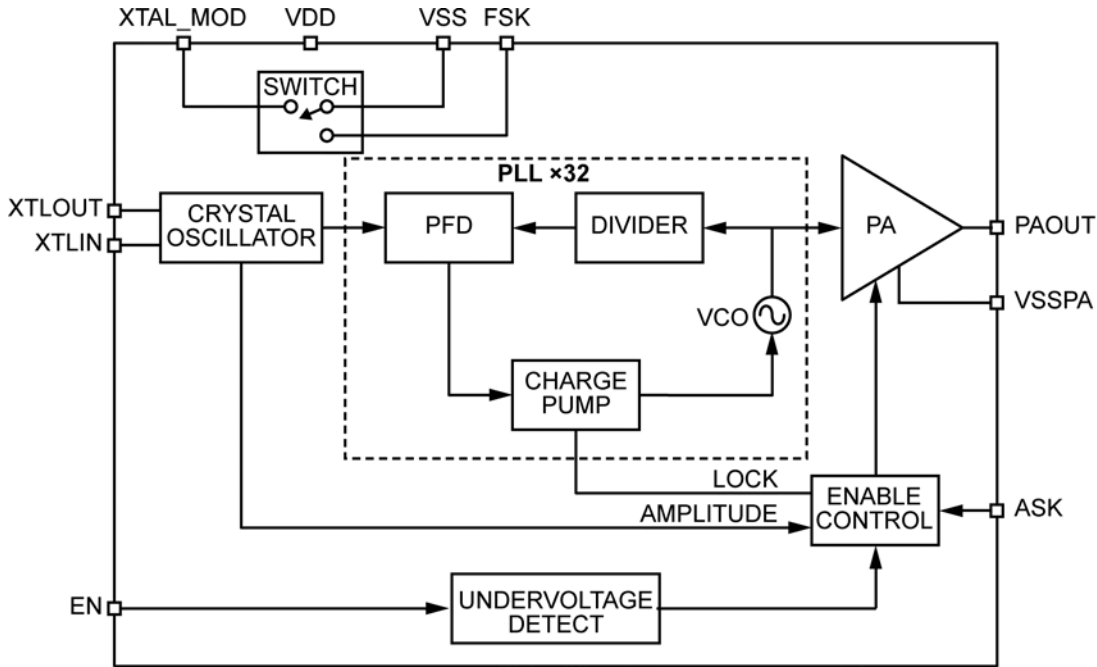

Figure 1. Functional Block Diagram MICRF112 10 Pin ASK/FSK Version

Functional Description

Figure 1 shows a functional block diagram of the MICRF112 transmitter. The MICRF112 can be best described as a phase-locked transmitter. The system can be partitioned into six functional blocks: crystal oscillator, PLLx32, power amplifier, enable control, undervoltage detect, and open-drain switch for FSK operation.

Crystal Oscillator

The reference oscillator is a crystal-based Pierce configuration. It is designed to accept crystals with frequencies from 9.375MHz to 14.0625MHz.

Crystal Oscillator Parameters for ASK Operation

Figure 2 shows a reference oscillator circuit configuration for ASK operation. The reference oscillator can drive crystals with an ESR range from 20Ω to 300Ω.

When the ESR of the crystal is at 20Ω, the crystal parameter limits are:

ESR	20Ω
C _{PAR}	2 to 10pF
C _{MO}	10 to 40fF

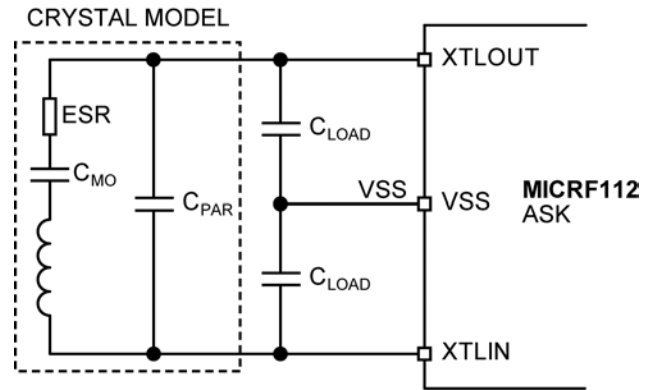

Figure 2. Reference Oscillator ASK Operation

When the ESR of the crystal is at 300Ω, the crystal parameter limits are:

ESR	300Ω
C _{PAR}	2 to 5pF
C _{MO}	10 to 40fF
C _{LOAD}	10 to 30pF

Crystal Oscillator for FSK Operation

Figure 3 shows the reference oscillator circuit configuration for FSK operation. To operate the MICRF112 in FSK mode, one additional capacitor is needed between XTLOUT pin and the XTAL_MOD pin. Crystal parameters for FSK operation are the same as for ASK operation except:

- When the ESR of crystal is at 20Ω , $C_{FSK} + C_{LOAD}$ must not exceed 70pF .
- When the ESR of crystal is at 300Ω , $C_{FSK} + C_{LOAD}$ must not exceed 30pF .

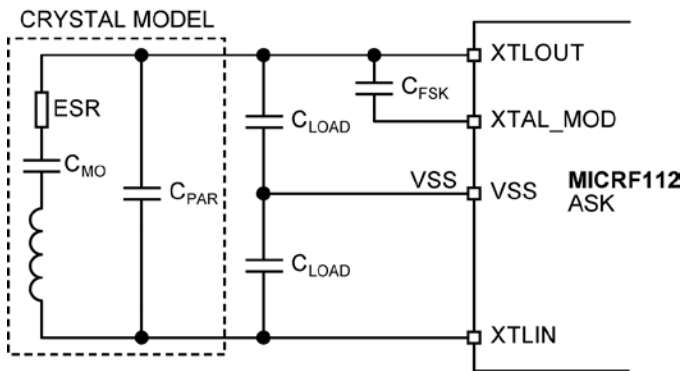

Figure 3. Reference Oscillator FSK Operation

PLLx32

The function of PLLx32 is to provide a stable carrier frequency for transmission. It is a “divided by 32” phase-locked oscillator.

Power Amplifier

The power amplifier serves two purposes: to buffer the VCO from external elements and to amplify the phase-locked signal. The power amplifier can produce $+10\text{dBm}$ at 3V (typical).

Enable Control

The enable control gates the ASK data. It only allows transmission when Lock, Amplitude, and Undervoltage Detect conditions are valid.

Undervoltage Detect

The undervoltage detect block senses operating voltage. If the operating voltage falls below 1.6V , the undervoltage detect block sends a signal to the enable control block to disable the PA.

Open-Drain Switch

The open-drain switch is used for FSK operation. FSK data is fed into the FSK pin. The FSK pin is connected to the gate of the open-drain switch. The open collector is connected to the XTAL_MOD pin. In Figure 3, a capacitor is shown connected from the XTAL_MOD pin to XTLOUT. When the FSK pin goes high, the capacitor between XTAL_MOD and XTLOUT pulls the frequency of REFOSC low.

Application Information

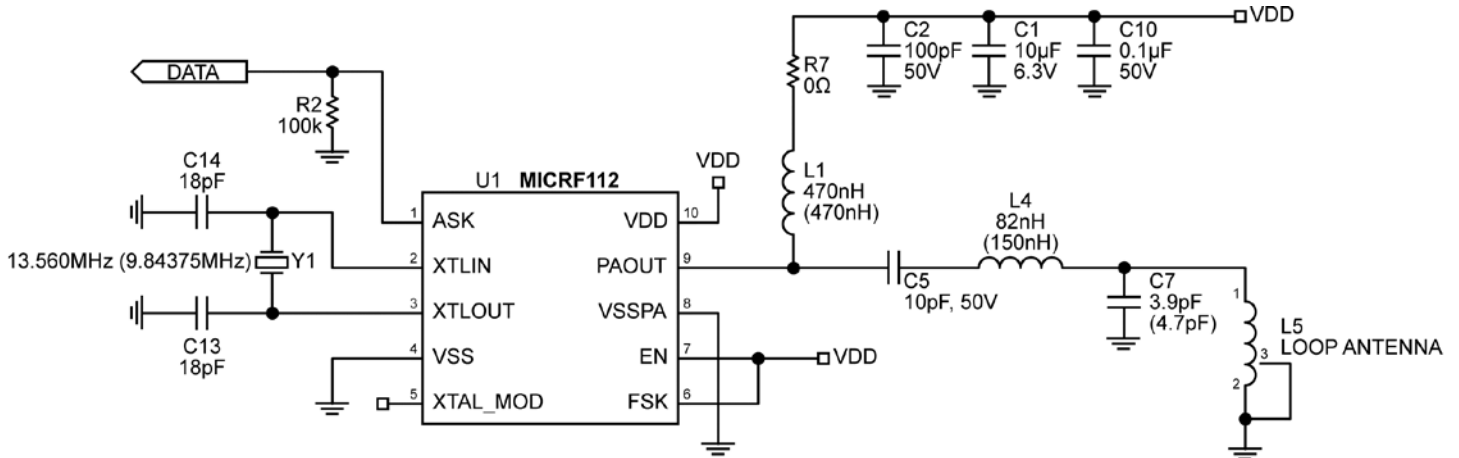

Figure 4. ASK 433.92MHz and 315MHz (MSOP)

Note: Values in parenthesis are for 315MHz.

The MICRF112 is ideal for driving a 50Ω source monopole or a loop antenna. Figure 4 is an example of a loop antenna configuration. Figure 4 also shows both 315MHz and 433.92MHz ASK configurations for a loop antenna. In addition to using a different crystal, modified values are needed for certain frequencies. These are listed in Table 1.

Frequency (MHz)	L1 (nH)	C5 (pF)	L4 (nH)	C7 (pF)	Y1 (MHz)
315.0	470	10	150	6.8	9.84375
433.92	680	10	82	4.7	13.5600

Table 1. Modified Frequency Values

The reference design shown in Figure 4 has an antenna optimized for using the matching network, as described in Table 1.

Power Control Using an External Resistor

R7 is used to adjust the RF output levels that may be needed to meet compliance. As an example, Tables 2 and 3 list typical values of conducted RF output levels and corresponding R7 resistor values for the 50Ω test board shown in the Test Circuit.

R7, Ω	Output Power, dBm	IDD, mA
0	10	6.7
75	8.5	6.3
100	8.0	6.2
500	1.6	4.13
1000	-3.8	4.87

Table 2. ASK Output Power at 1Kbps (Manchester) vs. External Resistor at 315MHz

R7, Ω	Output Power, dBm	IDD, mA
0	8.68	7.5
75	8.34	7.33
100	8.02	7.3
500	4.34	6.3
1000	0.42	5.5

Table 3. ASK Output Power at 1Kbps (Manchester) vs. External Resistor at 433.92MHz

Output Matching Network

Part of the function of the output network is to attenuate the second and third harmonics. When matching to a transmit frequency, be sure not only to optimize for maximum output power but to attenuate unwanted harmonics.

Layout Issues

PCB layout is extremely important to achieve optimum performance and consistent manufacturing results. Be careful with the orientation of the components to ensure that they do not couple or decouple the RF signal. PCB trace length should be short, to minimize parasitic inductance (1in ~ 20nH). For example, depending on inductance values, a 0.5in trace can change the

inductance by as much as 10%. To reduce parasitic inductance, the use of wide traces and a ground plane under signal traces is recommended. Use vias with low value inductance for components requiring a connection to ground.

Antenna Layout

The antenna trace layout affects directivity. No ground plane should be under the antenna trace. For consistent performance, do not place components inside the loop of the antenna. Gerbers for the Evaluation Board PCB, with a suggested layout are available on the Micrel web site at: www.micrel.com.

Demo Board PCB Layout

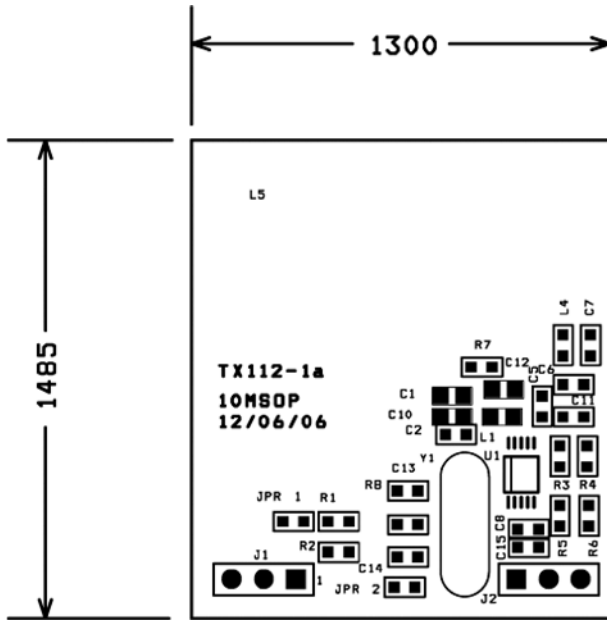

Assembly Drawing
MICRF112 Evaluation Board (MSOP)

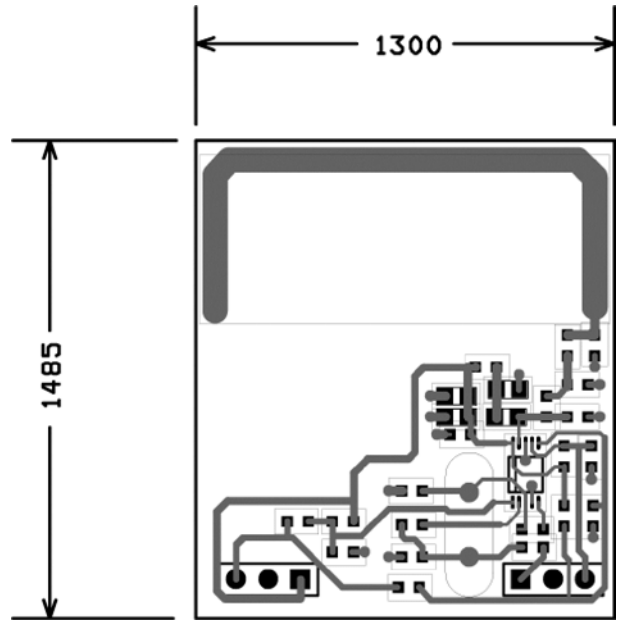

Top Layer
MICRF112 Evaluation Board (MSOP)

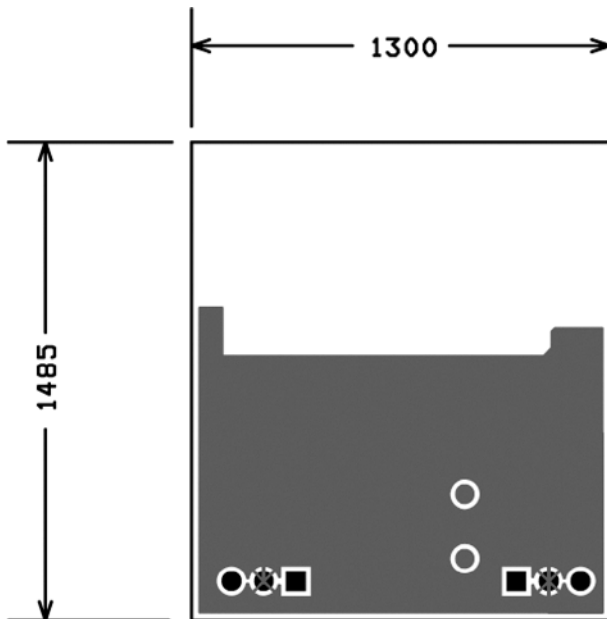

Bottom Layer
MICRF112 Evaluation Board (MSOP)

Evaluation Board Schematic

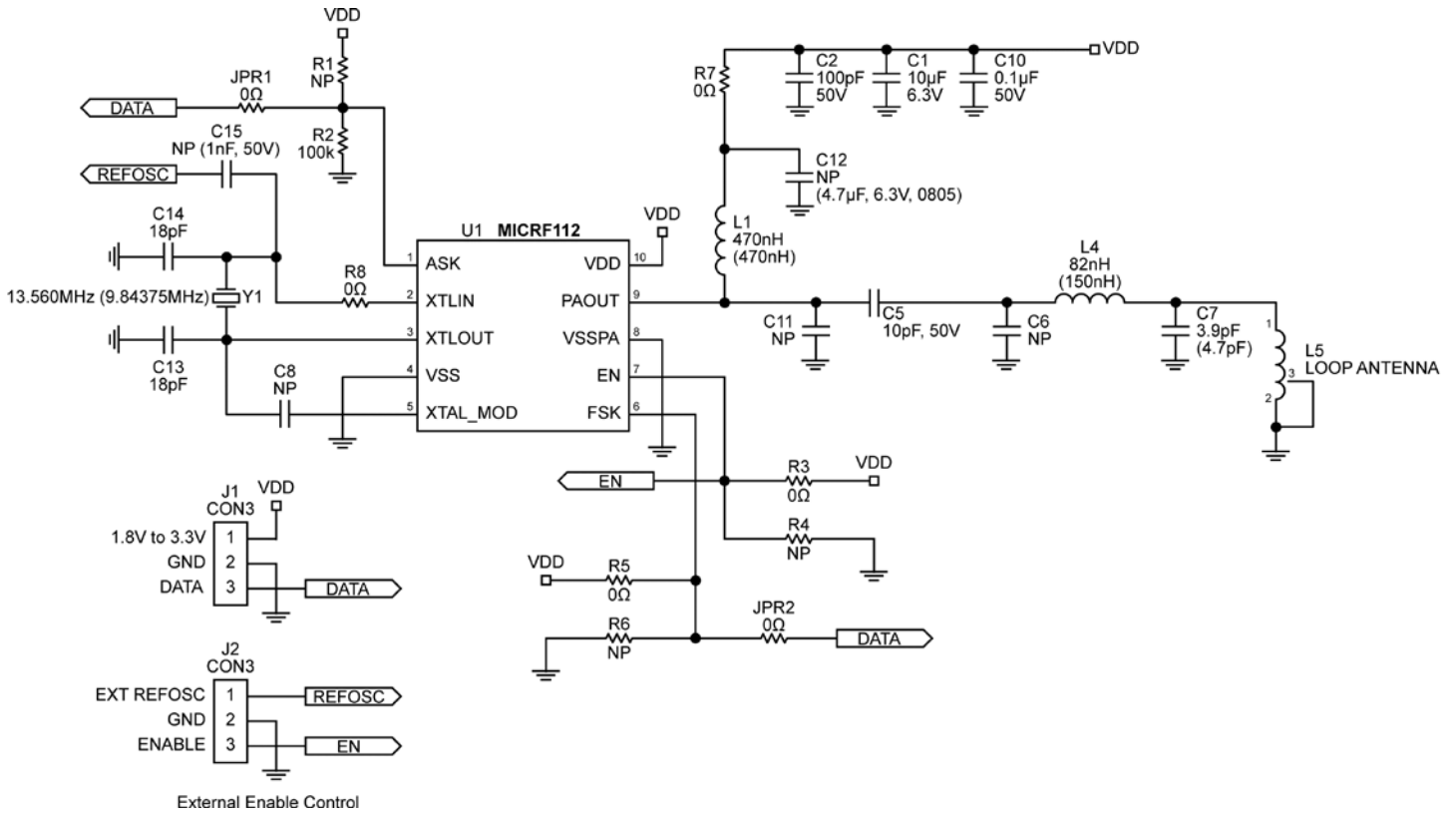

Figure 5. TX112-1 Evaluation Board Schematic (MSOP)

Note: Configuration is for ASK operation. Values in parenthesis are for 315MHz.

Functional Description of the TX112-1 Evaluation Board

The layout of the TX112-1 Evaluation Board PCB is shown on page 15. Figure 5 is a detailed schematic of the TX112-1. Components labeled “NP” use different configurations for FSK operation. Table 2 describes each header pin connector used in the evaluation board.

Pin	Function Name	Functional Description
J1-1	VDD	1.8V to 3.6V
J1-2	Ground	VSS
J1-3	ASK INPUT	Modulating Data Input, ASK or FSK
J2-1	REF-OSC	External Reference Input
J2-2	GROUND	VSS
J2-3	ENABLE	Enable Input, Active High

Table 4. Header Pin Connectors

TX112-1-433.92 ASK Bill of Materials

Item	Part Number	Manufacturer	Description	Qty.
C1	GRM21BR60J106KE01L	Murata ⁽¹⁾	10µF Capacitor, 0805	1
C2	GRM1885C1H101JA01D	Murata	100pF Capacitor, 0603	1
C5	GRM1885C1H100JA01D	Murata	10pF Capacitor, 0603	1
R1,R4,R6				3
C6,C8,C11,C12,C15				5
C7	GRM1885C1H4R7JA01D	Murata	4.7pF Capacitor, 0603	1
C10	GRM188F51H104ZA01D	Murata	0.1µF Capacitor, 0603	1
C13,C14	GRM1885C1H180JA01D	Murata	18pF Capacitor, 0603	2
J1,J2	TSHR-114-S-02-A-GT		CON3	2
L1	0805CS-680XJB	Coilcraft ⁽²⁾	470nH Inductor, 0805	1
L4	0603CS-082NXJB	Coilcraft	150nH Inductor, 0603	1
L5	ANTENNA LOOP, Part of PCB		Antenna	1
R2	CRCW0603100KFKEA	Vishay ⁽³⁾	100kΩ Resistor, 0603	1
R3,R5,R7 R8,JPR1,JPR2	CRC06030000Z0EA	Vishay	0Ω Resistor, 0603	6
U1	MICRF112YMM	Micrel⁽⁴⁾	300MHz to 450MHz, +10dBm ASK/FSK Transmitter with Shutdown	1
Y1	SA-13.5600-F-10-C-3-3	HIB ⁽⁵⁾	13.560MHz XTAL	1

Notes:

1. Murata Tel: www.murata.com.
2. Coilcraft: www.coilcraft.com.
3. Vishay Tel: www.vishay.com
4. **Micrel, Inc.:** www.micrel.com.
5. HIB: www.hib.com.br.

Tx112-1-315MHz ASK Bill of Materials

Item	Part Number	Manufacturer	Description	Qty.
C1	GRM21BR60J106KE01L	Murata ⁽¹⁾	10 μ F Capacitor, 0805	1
C2	GRM1885C1H101JA01D	Murata	100pF Capacitor, 0603	1
C5	GRM1885C1H1000JA01D	Murata	10pF Capacitor, 0603	1
R1,R4,R6				3
C6,C8,C11,C12,C15				5
C7	GRM1885C1H6R8JA01D	Murata	4.7pF Capacitor, 0603	1
C10	GRM188F51H104ZA01D	Murata	0.1 μ F Capacitor, 0603	1
C13,C14	GRM1885C1H180JA01D	Murata	18pF Capacitor, 0603	2
J1,J2	TSHR-114-S-02-A-GT		CON3	2
L1	0805CS-470XJB	Coilcraft ⁽²⁾	470nH Inductor, 0805	1
L4	0603CS-R15XJB	Coilcraft	150nH Inductor, 0603	1
L5	ANTENNA LOOP, Part of PCB		Antenna	1
R2	CRCW0603100KFKEA	Vishay ⁽³⁾	100k Ω Resistor, 0603	1
R3,R5,R7 R8,JPR1,JPR2	CRC06030000Z0EA	Vishay	0 Ω Resistor, 0603	6
U1	MICRF112YMM	Micrel⁽⁴⁾	300MHz to 450MHz, +10dBm ASK/FSK Transmitter with Shutdown	1
Y1	SA-9.84375-F-10-C-3-3	HIB ⁽⁵⁾	9.84375MHz XTAL	1

Notes:

1. Murata Tel: www.murata.com.
2. Coilcraft: www.coilcraft.com.
3. Vishay Tel: www.vishay.com.
4. Micrel, Inc.: www.micrel.com.
5. HIB: www.hib.com.br.

FSK Operation

The Bill of Materials tables describe the components needed for ASK operation for 433.92MHz and 315MHz.

Table 5 lists the component values that change between ASK and FSK operation. Note that use of a high FSK data rate may excite parasitic resonant modes with some crystal types. Recommended crystals from the Bill of Materials tables are good for both ASK and FSK.

Mode	R1	R2	R5	R6	JPR1	JPR2	C8
ASK	NP	100k Ω	0 Ω	NP	0 Ω	NP	NP
FSK	0 Ω	NP	NP	100k Ω	NP	0 Ω	3.3pF ⁽¹⁾ 10pF ⁽²⁾

Notes:

1. C8 = 3.3pF for 1kHz using HC49/U or HC49US type crystals.
2. C8= 10pF for 10kHz using HC49/U, (high profile) only.

Table 5. ASK and FSK Settings

	R3	R4
Constant ON	0 Ω	NP
External Standby Control	NP	100k Ω

Table 6. Enable Control (Shutdown)

Package Information⁽¹⁾

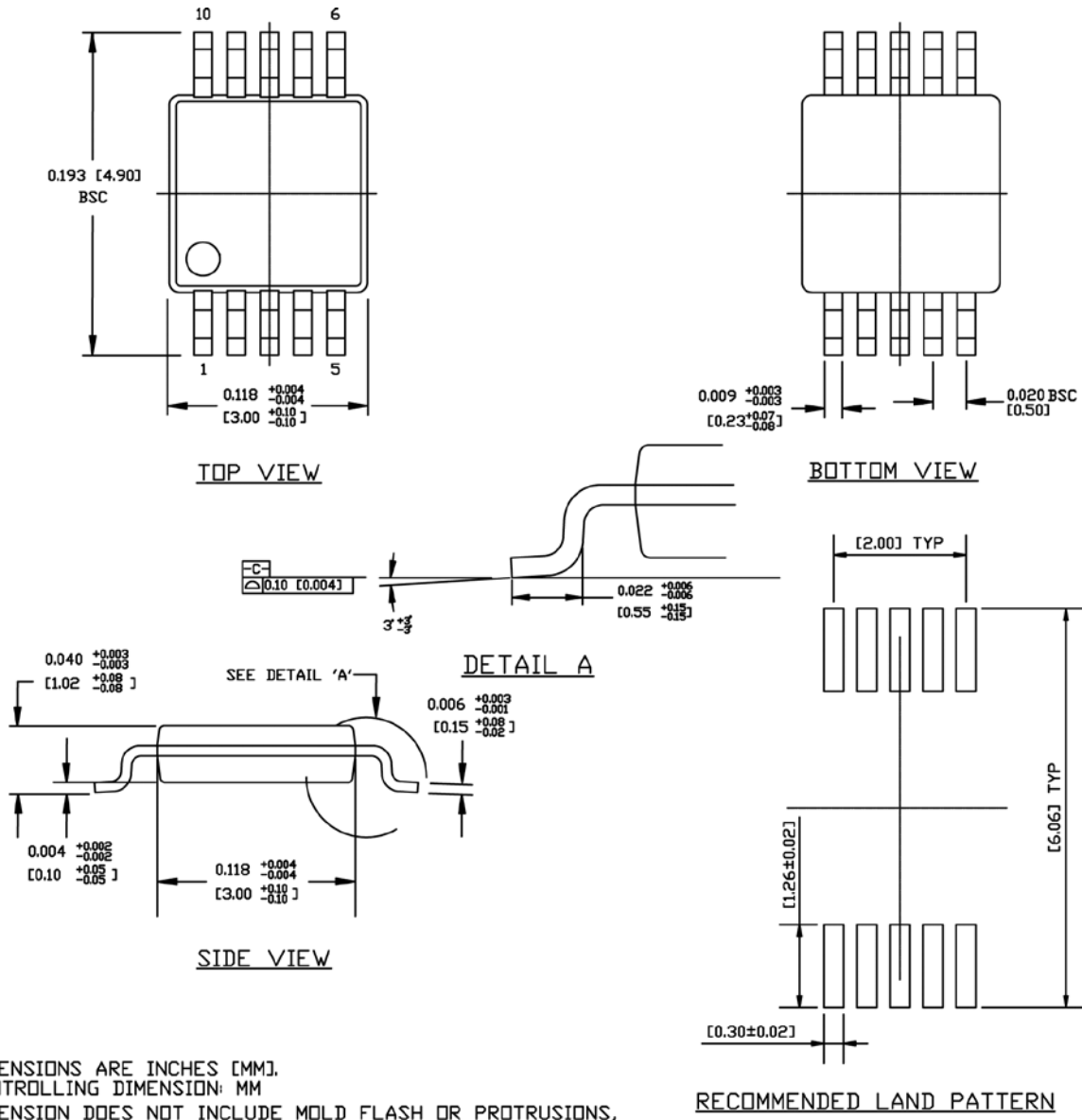

- NOTES:**
1. DIMENSIONS ARE INCHES [MM].
 2. CONTROLLING DIMENSION: MM
 3. DIMENSION DOES NOT INCLUDE MOLD FLASH OR PROTRUSIONS, EITHER OF WHICH SHALL NOT EXCEED 0.008 [0.20] PER SIDE.

10-Pin MSOP Package Type (YMM)

Note: The Pin1 marking symbol could be a circle, triangle, or other symbol. Package information is correct as of the publication date. For updates and most current information, go to www.micrel.com.

Package Information⁽¹⁾ (Continued)

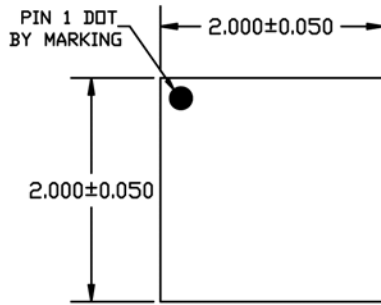

TOP VIEW
NOTE: 1,2,3,4

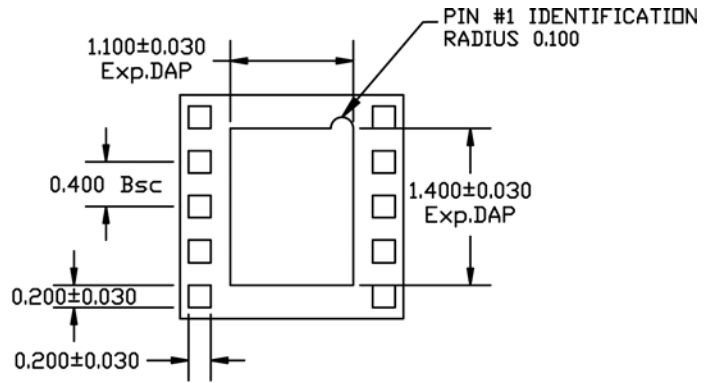

BOTTOM VIEW
NOTE: 1,2,3,4

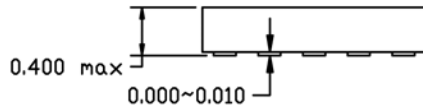

SIDE VIEW
NOTE: 1,2,3,4

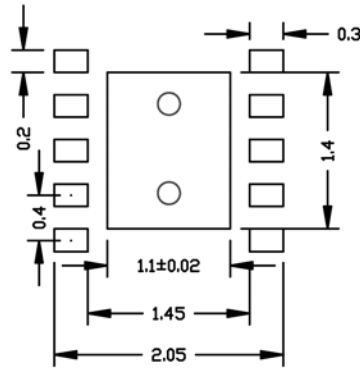

RECOMMENDED LAND PATTERN
NOTE: 5

- NOTE:
1. ALL DIMENSIONS ARE IN MILLIMETERS.
 2. MAX. PACKAGE WARPAGE IS 0.08 mm.
 3. MAXIMUM ALLOWABLE BURRS IS 0.076 mm IN ALL DIRECTIONS.
 4. PIN #1 ID ON TOP WILL BE LASER MARKED.
 5. Red Circle Indicates Thermal Via. Size should be 0.200mm to 0.0350mm in diameter, 0.80mm pitch, and should be connected to ground plane for maximum thermal performance.

10-Pin Ultra-Thin DFN 2mm x 2mm x 0.4mm (MU)

Note: The Pin1 marking symbol could be a circle, triangle, or other symbol. Package information is correct as of the publication date. For updates and most current information, go to www.micrel.com.

MICREL, INC. 2180 FORTUNE DRIVE SAN JOSE, CA 95131 USA
TEL +1 (408) 944-0800 FAX +1 (408) 474-1000 WEB <http://www.micrel.com>

Micrel makes no representations or warranties with respect to the accuracy or completeness of the information furnished in this data sheet. This information is not intended as a warranty and Micrel does not assume responsibility for its use. Micrel reserves the right to change circuitry, specifications and descriptions at any time without notice. No license, whether express, implied, arising by estoppel or otherwise, to any intellectual property rights is granted by this document. Except as provided in Micrel's terms and conditions of sale for such products, Micrel assumes no liability whatsoever, and Micrel disclaims any express or implied warranty relating to the sale and/or use of Micrel products including liability or warranties relating to fitness for a particular purpose, merchantability, or infringement of any patent, copyright or other intellectual property right.

Micrel Products are not designed or authorized for use as components in life support appliances, devices or systems where malfunction of a product can reasonably be expected to result in personal injury. Life support devices or systems are devices or systems that (a) are intended for surgical implant into the body or (b) support or sustain life, and whose failure to perform can be reasonably expected to result in a significant injury to the user. A Purchaser's use or sale of Micrel Products for use in life support appliances, devices or systems is a Purchaser's own risk and Purchaser agrees to fully indemnify Micrel for any damages resulting from such use or sale.