



MIC5159

Programmable Current Limit μ Cap LDO Regulator Controller

General Description

Micrel's MIC5159 is a precision-voltage regulator controller. Used with an external P-Channel MOSFET, the MIC5159 forms a two-chip low-dropout regulator capable of driving a wide range of output currents.

The MIC5159 operates from an input of 1.65V to 5.5V. The low input voltage allows the MIC5159 to operate off of high power 1.8V rails to generate lower voltages such as 1.5V.

Features of the MIC5159 include enable input and current-limit protection. As a μ Cap design, the MIC5159 is stable with ceramic output capacitors.

The MIC5159 is packaged in the IttyBitty[®] SOT-23-6, and is offered in fixed and adjustable output voltages. Junction temperature range of the MIC5159 is from -40°C to $+125^{\circ}\text{C}$.

Features

- Fast transient response
- **Input voltage range: V_{IN} 1.65V to 5.5V**
- $\pm 1.0\%$ initial output tolerance
- Fixed 1.8V or adjustable output voltage down to 1.25V
- **Stable with ceramic output capacitor**
- **Capable up to 10A**
- Excellent line and load regulation specifications
- Logic-controlled shutdown
- Programmable current limit
- Current-limit protection
- IttyBitty[®] SOT-23-6 package
- Available temperature range: -40°C to $+125^{\circ}\text{C}$
-

Applications

- Ultra-high current, ultra-low dropout voltage regulator
- High-efficiency linear power supplies
- Low-voltage distributed power
- Fixed telecom
- Multimedia and PC power supplies
- Battery chargers
- Low-voltage DSP, microprocessor and microcontroller power supplies

Typical Application

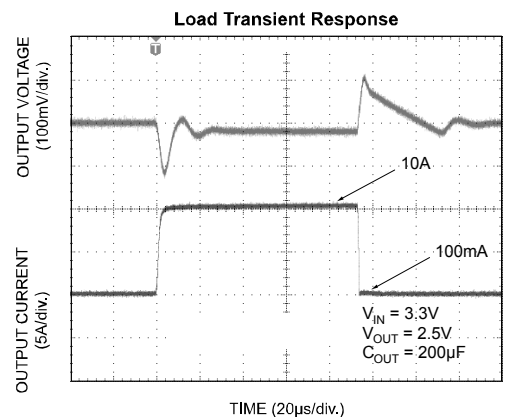
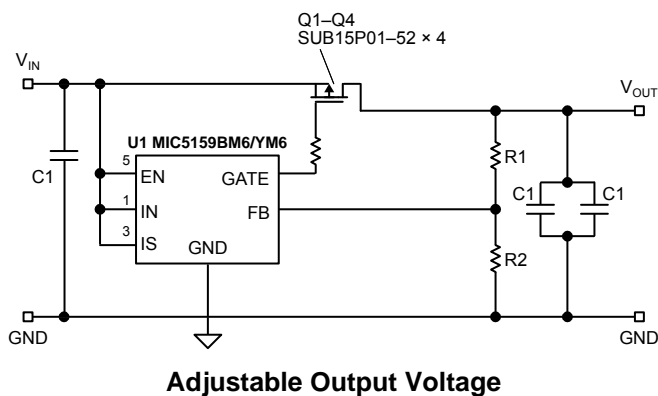

IttyBitty is a registered trademark of Micrel, Inc.

Micrel Inc. • 2180 Fortune Drive • San Jose, CA 95131 • USA • tel +1 (408) 944-0800 • fax + 1 (408) 474-1000 • <http://www.micrel.com>

June 2006

M9999-062706

Ordering Information

Part Number		Marking	Voltage*	Junction Temp. Range	Package
Standard	Pb-Free				
MIC5159BM6	MIC5159YM6	LZAA	Adj.	-40° to +125°C	SOT-23-6
MIC5159-1.8BM6	MIC5159-1.8YM6	LZ18	1.8V.	-40° to +125°C	SOT-23-6
MIC5159-3.0BM6	MIC5159-3.0YM6	LZ30	3.0V	-40° to +125°C	SOT-23-6

Note:

Other Voltage available. Contact Micrel for details.

Pin Configuration

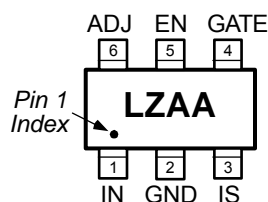

SOT-23-6 (M6)
Adjustable Voltage Version

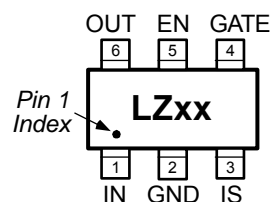

SOT-23-6 (M6)
Fixed Voltage Version

Pin Description

Pin Number	Pin Name	Pin Function
1	IN	Input Voltage.
2	GND	Ground.
3	IS	Current Sense: IS must be tied to VIN pin if the current limit feature is not used.
4	GATE	Gate drive of the external P-Channel MOSFET.
5	EN	Enable Input: Logic Level ON/OFF control. Logic high = ON; logic low = OFF.
6	ADJ	Adjustable Regulator Feedback Input: Connect to resistor voltage divider.
	OUT	Output Voltage: Connect to drain of P-Channel MOSFET to regulate output to proper voltage.

Absolute Maximum Ratings⁽¹⁾

Supply Voltage (V_{IN})	+6.0V
Enable Input Voltage (V_{EN})	+6.0V
Power Dissipation ($P_{D(max)}$)	Note 3
Storage Temperature (T_s)	-65°C to +150°C
Lead Temperature (soldering, 5 sec.)	260°C
EDS Rating ⁽⁴⁾	2kV

Operating Ratings⁽²⁾

Supply voltage (V_{IN})	+1.65V to +5.5V
Enable Input Voltage (V_{EN})	0V to +5.5V
Junction Temperature (T_J)	-40°C ≤ T_J ≤ +125°C
Package Thermal Resistance	
SOT-23-6 (θ_{JA})	235°C/W

Electrical Characteristics⁽⁵⁾

$T_A = 25^\circ\text{C}$ with $V_{IN} = V_{OUT} + 1\text{V}$; $V_{EN} = 1.2\text{V}$, $C_{IN} = C_{OUT} = 10\mu\text{F}$, ceramic, $I_{OUT} = 10\text{mA}$; **bold** values indicate $-40^\circ\text{C} < T_J < +125^\circ\text{C}$; unless otherwise specified, **Note 3**

Parameter	Condition	Min	Typ	Max	Units
Output Voltage Accuracy	At 25°C	-1		+1	%
	Over temperature range	-2		+2	%
Output Voltage Line Regulation	$V_{IN} = V_{OUT} + 1.0\text{V}$ to 5.5V	-0.1	0.007	+0.1	%/V
Output Voltage Load Regulation	$I_L = 10\text{mA}$ to 1.0A		0.2	1.0	%
Ground Pin Current ⁽⁶⁾	$V_{EN} \leq 0.2\text{V}$ (MIC5159 OFF)		15	30	μA
	$V_{EN} \geq 1.2\text{V}$ (MIC5159 ON)		10	20	mA
Adjust Pin Bias Current				1	μA
Maximum V_{GS}	(PFET fully ON); $V_{IN} = 5.0\text{V}$	4.5			V
	(PFET fully ON); $V_{IN} = 3.3\text{V}$	3.1			V
	(PFET fully ON); $V_{IN} = 2.5\text{V}$	2.3			V
Current-Limit Threshold	$V_{IN} - V_{IS}$	40	50	65	mV
Start-up Time	$V_{EN} = V_{IN}$		30	150	μs
Enable Input					
Enable Input Threshold	Regulator enabled	1.2			V
	Regulator shutdown			0.2	V
	Enable hysteresis	20	50	250	mV
Enable Pin Input Current	Independent of state		0.01		nA
				1	μA

Notes:

- Exceeding the absolute maximum rating may damage the device.
- The device is not guaranteed to function outside its operating rating.
- $P_{D(max)} = (T_{J(max)} - T_A) \div \theta_{JA}$, where θ_{JA} depends upon the printed circuit layout, see "Applications Information."
- Devices are ESD sensitive. Handling precautions recommended. Human body model, 1.5k in series with 100pF.
- Specification for packaged product only.
- I_{GND} is the quiescent current. $I_{IN} = I_{GND} + I_{OUT}$.

Typical Characteristics

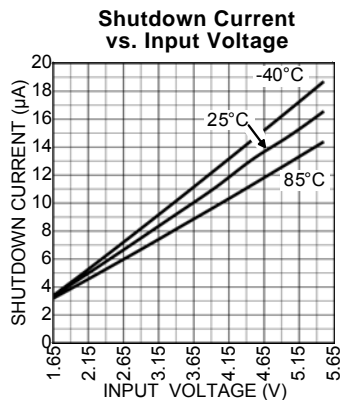
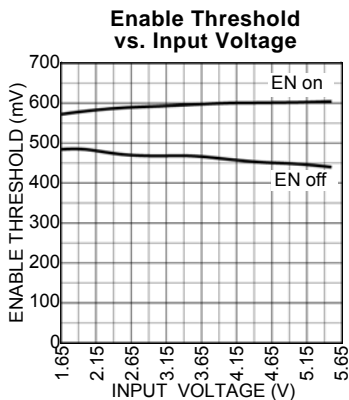
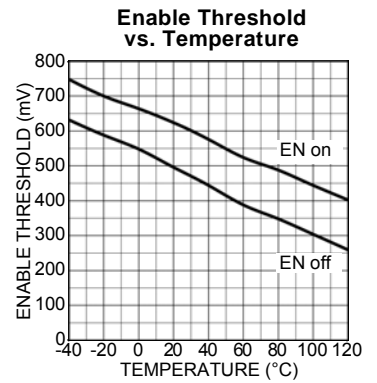
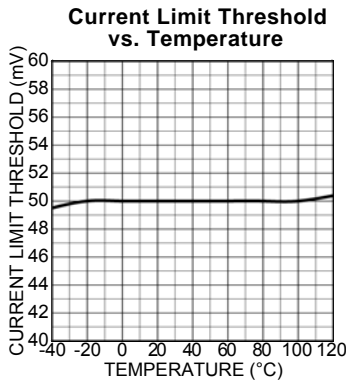
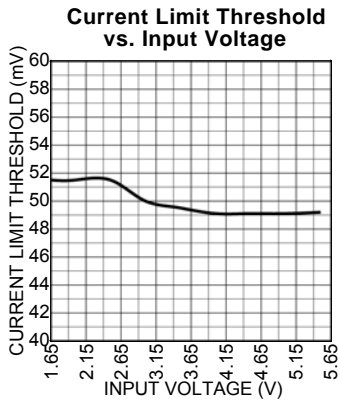
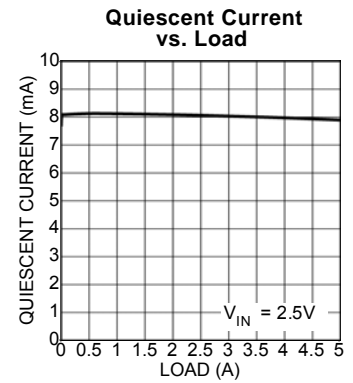
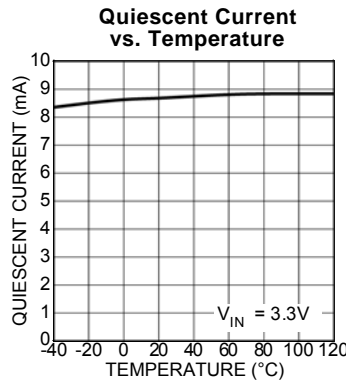
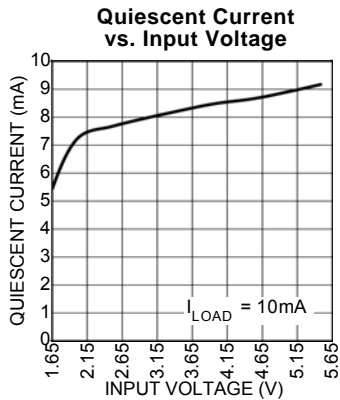
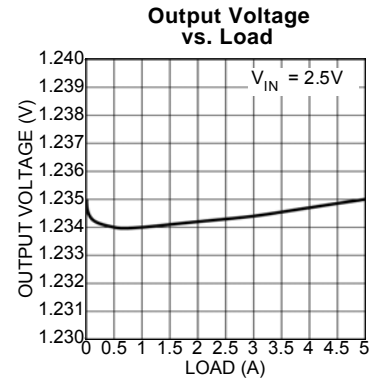
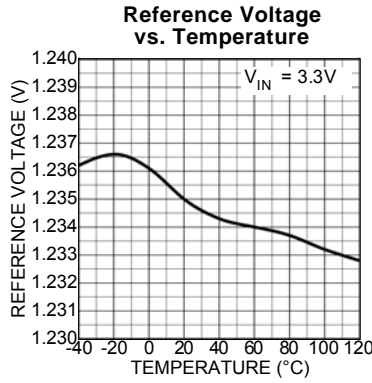
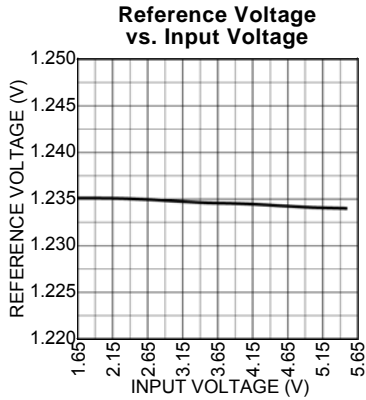

Functional Characteristics

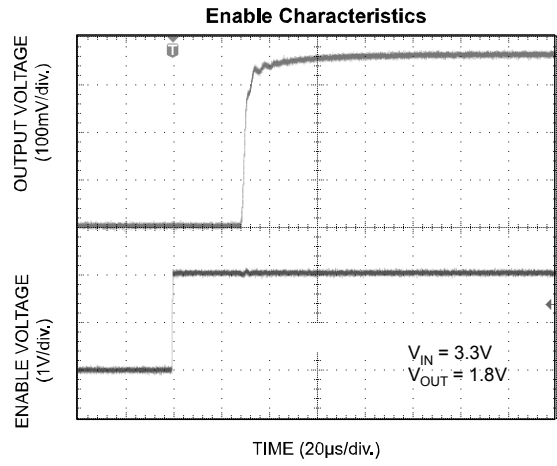
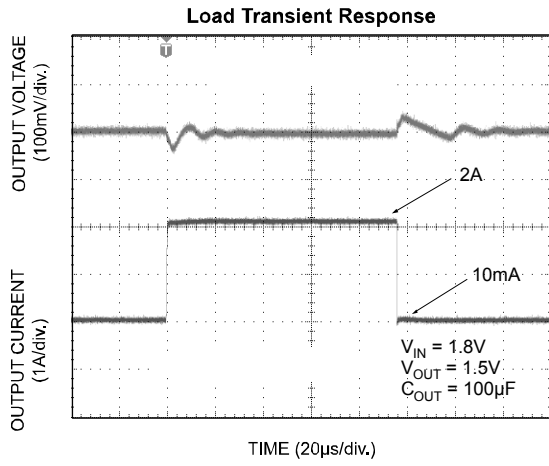

Application Information

The MIC5159 is a high performance voltage regulator controller. When used with an external P-Channel MOSFET and a tiny ceramic output capacitor, it forms a wide variety of simple, inexpensive ultra-low-dropout voltage regulators.

Current Sense Resistor Selection

A current sense resistor placed between the input and the current sense pin (IS) allows for programmability of the current limit. This resistor can simply be calculated by:

$$R_{\text{SENSE}} = \left(\frac{50\text{mV}}{I_{\text{OUT}}} \right)$$

Where I_{OUT} is the maximum output current. For example, the current sense resistor for a 2.5V_{IN} to 1.8V_{OUT}, 5A, linear regulator calculates as follows:

$$R_{\text{SENSE}} = \left(\frac{50\text{mV}}{5\text{A}} \right)$$

$$R_{\text{SENSE}} = 10\text{m}\Omega$$

P-Channel MOSFET Selection

The P-Channel MOSFET selected for use with the MIC5159 must satisfy the following requirements:

- Input voltage
- Gate threshold
- Load current
- Dropout voltage (input-to-output differential)
- Thermal performance

To prevent damage to the P-Channel MOSFET, the maximum input voltage ($V_{\text{IN(max)}}$) must be less than its drain-source breakdown voltage (BV_{DS}). In addition, the minimum input voltage ($V_{\text{IN(min)}}$) must be greater than or equal to the gate threshold voltage (V_{GS}) of the P-Channel MOSFET. For a given output current and dropout requirement, the ON-resistance ($R_{\text{DS(ON)}}$) of the P-Channel MOSFET must also be determined. The minimum $R_{\text{DS(ON)}}$ of the P-Channel MOSFET is calculated as follows:

$$R_{\text{DS(ON)}} = \left(\frac{(V_{\text{IN(MIN)}} - V_{\text{OUT}})}{I_{\text{OUT(MAX)}}} \right) - R_{\text{SENSE}}$$

Where $I_{\text{OUT(max)}}$ is the maximum output current and R_{SENSE} is the current sense resistor.

For example, the MIC5159-1.8BM6 is used with an external MOSFET to form a 5A LDO with an input of 2.5V. Either a 2.5V or 1.8V gate threshold MOSFET can be selected. The minimum $R_{\text{DS(ON)}}$ is calculated as:

$$R_{\text{DS(ON)}} = \left(\frac{(2.5\text{V} - 1.8\text{V})}{5\text{A}} \right) - 10\text{m}\Omega$$

$$R_{\text{DS(ON)}} = 130\text{m}\Omega$$

According to the above calculation, the minimum $R_{\text{DS(ON)}}$ is 130m Ω for a 2.5V to 1.8V LDO with 5A of output current. For this design, the $R_{\text{DS(ON)}}$ for the FETs should maintain better than 130m Ω over the required temperature, current, and voltage conditions.

Placing two or more P-Channel FETs in parallel can reduce the total $R_{\text{DS(ON)}}$ of the regulator. This also aids thermal dissipation by sharing the current and heat between the multiple FETs.

Thermal Considerations

Linear regulators are simple to use. The most complicated design parameters to consider are thermal characteristics. Since the MIC5159 offers no thermal protection, thermal design requires the following application-specific parameters:

- Maximum ambient temperature (T_{A})
- Output current (I_{OUT})
- Output voltage (V_{OUT})
- Input voltage (V_{IN})

First, calculate the maximum power dissipation of the regulator:

$$P_{\text{D}} = (V_{\text{IN}} - V_{\text{OUT}}) \times I_{\text{OUT}}$$

Ground current can generally be ignored. The amount of power dissipated by ground current and input voltage is minimal. Minimum θ_{JA} for the MOSFET can be calculated using the following formula:

$$\theta_{\text{JA}} = \left(\frac{(T_{\text{J(MAX)}} - T_{\text{A}})}{P_{\text{D}}} \right)$$

Where $T_{\text{J(max)}}$ is equal to the maximum die temperature of the P-Channel.

$$\theta_{\text{JA}} = \theta_{\text{JC}} + \theta_{\text{CS}} + \theta_{\text{SA}}$$

Example

For the same regulator, 2.5V_{IN} to 1.8V_{OUT} at 5A with an ambient temperature of 60°C:

$$P_{\text{D}} = (2.5\text{V} - 1.8\text{V}) \times 5\text{A}$$

$$P_{\text{D}} = 3.5\text{W}$$

Where V_{IN} is the maximum V_{IN} and I_{OUT} is the maximum I_{OUT} .

The P-Channel MOSFET must be able to dissipate 3.5W. The minimum θ_{JA} to maintain a maximum T_{J} of 150°C (max.) T_{J} according to a typical MOSFET data sheet is as follows:

$$\theta_{\text{JA}} = \frac{(150^{\circ}\text{C} - 60^{\circ}\text{C})}{3.5\text{W}}$$

$$\theta_{JA} = 25.71^{\circ}\text{C/W}$$

The heatsink and MOSFET must have a combined thermal resistance to meet the above criteria.

The typical thermal resistance from the junction to the case (θ_{JC}) of a TO-263 (D² pack) is 6°C/W. Adding 0.2°C/W for case to sink thermal resistance (θ_{CS}), the heatsink must have a sink to ambient thermal resistance (θ_{SA}) of:

$$\theta_{SA} = \theta_{JA} - (\theta_{JC} + \theta_{CS})$$

$$\theta_{SA} = 25.71^{\circ}\text{C/W} - (6^{\circ}\text{C/W} + 0.2^{\circ}\text{C/W})$$

$$\theta_{SA} = 19.51^{\circ}\text{C/W}$$

According to the calculations, the heatsink must have a θ_{SA} of 19.51°C/W or better.

For a full discussion of heat sinking and thermal effects on voltage regulators, refer to the “Regulator Thermals” section of Micrel’s *Designing with Low-Dropout Voltage Regulators* handbook.

Short-Circuit Current Limit

The above thermal design calculations apply to normal operation. In the case where the P-Channel MOSFET must survive extended periods of short-circuit current, another approach for thermal design must be considered. Due to the fact that the MIC5159 delivers constant current limiting, power dissipated by the MOSFET is equal to the input voltage multiplied by the maximum output current.

Figure 1 shows a simple, inexpensive circuit that allows the current limiting to be re-entrant. This reduces power dissipation in current limited conditions. As the output voltage begins to drop, the differential voltage across the input and output increases. This pulls the current sense voltage lower, reducing the amount of output current to maintain 50mV across the sense resistor. This reduction in output current equates to a reduction in power dissipation in the MOSFET. Figures 2 and 3 show a comparison of linear current limiting versus the re-entrant current limiting scheme implemented in Figure 1.

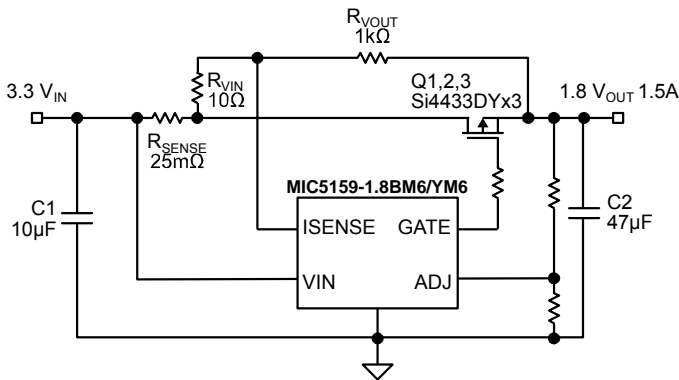

Figure 1. Re-Entrant Current Limit

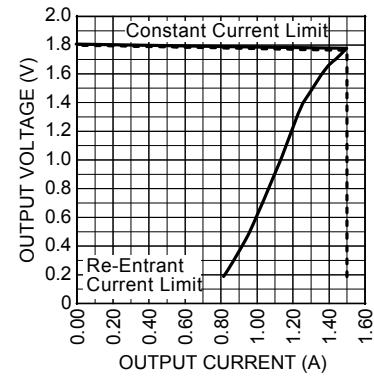

Figure 2. Output Voltage Characteristics Re-Entrant Current Limit

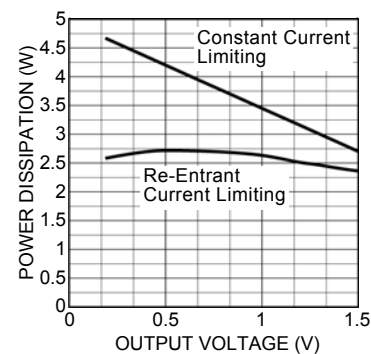

Figure 3. Power Dissipation vs. Output Voltage

Enable/Shutdown

The MIC5159 comes with an active-high enable pin that allows the regulator to be disabled. Forcing the enable pin low disables the regulator and sends it into a low off-mode-current state. Forcing the enable pin high enables the output voltage. This part is CMOS and the enable pin cannot be left floating; a floating enable pin may cause an indeterminate state on the output.

Output Capacitor

The MIC5159 requires an output capacitor to maintain stability and improve transient response. Proper selection is important to ensure proper operation. The MIC5159 output capacitor selection is highly dependent upon the components and the application. With a very high gate charge (gate capacitance) MOSFET, the output requires a much larger valued ceramic capacitor for stability. As an alternative to a large valued ceramic capacitor, a smaller-valued tantalum capacitor can be used to provide stability. At higher load currents, lower R_{DS(ON)} MOSFETs are used; these MOSFETs typically having much larger gate charge. If the application does not require ultra-low-dropout voltage, smaller values of ceramic capacitance may be used.

Input Capacitor

An input capacitor of 1.0 μ F or greater is recommended when the device is more than 4 inches away from the bulk AC supply capacitance or when the supply is a battery. Small, surface mount, ceramic capacitors can be used for bypassing the input to the regulator, further improving the integrity of the output voltage. Larger input capacitors may be required depending on the impedance of the source and the output load requirements.

Layout Considerations

Input and output capacitor placement should be as close as possible to the input and output, respectively. Trace resistance between the current sense and the MOSFET source should be minimized. Trace resistance will increase dropout voltage. This is more of a factor at higher output currents.

Also, a minimum amount of distance between the gate pin, on the MIC5159, and the P-Channel MOSFET gate is recommended. A long trace can create a small parasitic inductor. This, coupled to the gate capacitance of the MOSFET, can create a high frequency tank circuit. A small 50 Ω resistor in series with the gate may be required to eliminate high-frequency noise.

Adjustable Regulator Design

The MIC5159 allows programming the output voltage anywhere between 1.235V to V_{IN} . Two resistors are used. See Figure 4. The resistor values are calculated by:

$$R1 = R2 \times \left(\left(\frac{V_{OUT}}{1.235} \right) - 1 \right)$$

Where V_{OUT} is the desired output voltage.

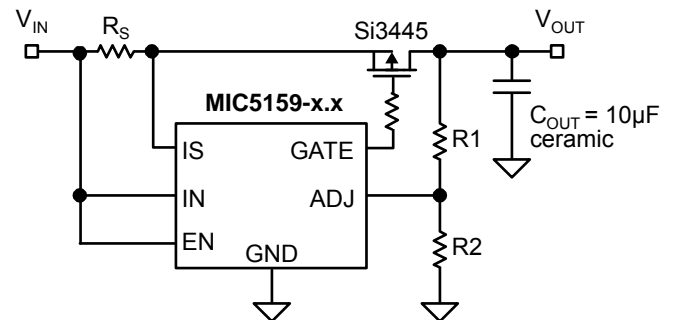

Figure 4. Adjustable Regulator Design

Designing with MIC5159

The following section details:

- Application examples of possible input/output configurations with related schematics designator.
- Schematics with “Bill of Materials” recommendation, dropout performance and maximum output current for each FET combination.
- Further advice on MOSFET selection.

3.3V_{IN} to 2.5V_{OUT} Conversion

I _{OUT}	C _{OUT}	MOSFET	Package	Schematic
1.0A	10μF	Si4433DY	SO-8	C
2.5A	22μF	Si4433DY x2	SO-8	D
2.5A	10μF	SUB15P01-52	D2PAK	H
3.5A	44μF	Si4433DY x3	SO-8	E
5.0A	44μF	Si4433DY x4	SO-8	F
5.0A	22μF	SUB15P01-52 x2	D2PAK	I
7.5A	44μF	SUB15P01-52 x3	D2PAK	J
10.0A	44μF	SUB15P01-52 x4	D2PAK	K

3.3V_{IN} to 1.8V_{OUT} Conversion

I _{OUT}	C _{OUT}	MOSFET	Package	Schematic
0.6A	10μF	Si4433DY	SO-8	C
1.25A	22μF	Si4433DY x2	SO-8	D
1.25A	10μF	SUB15P01-52	D2PAK	H
2.0A	44μF	Si4433DY x3	SO-8	E
2.5A	44μF	Si4433DY x4	SO-8	F
2.5A	22μF	SUB15P01-52 x2	D2PAK	I
3.75A	44μF	SUB15P01-52 x3	D2PAK	J
5.0A	44μF	SUB15P01-52 x4	D2PAK	K

3.3V_{IN} to 1.5V_{OUT} Conversion

I _{OUT}	C _{OUT}	MOSFET	Package	Schematic
0.5A	10μF	Si4433DY	SO-8	C
1.0A	22μF	Si4433DY x2	SO-8	D
1.0A	10μF	SUB15P01-52	D2PAK	H
1.5A	44μF	Si4433DY x3	SO-8	E
2.0A	44μF	Si4433DY x4	SO-8	F
2.0A	22μF	SUB15P01-52 x2	D2PAK	I
3.0A	44μF	SUB15P01-52 x3	D2PAK	J
4.25A	44μF	SUB15P01-52 x4	D2PAK	K

3.3V_{IN} to 1.25V_{OUT} Conversion

I _{OUT}	C _{OUT}	MOSFET	Package	Schematic
0.4A	10μF	Si4433DY	SO-8	C
0.75A	22μF	Si4433DY x2	SO-8	D
0.75A	10μF	SUB15P01-52	D2PAK	H
1.25A	44μF	Si4433DY x3	SO-8	E
1.75A	44μF	Si4433DY x4	SO-8	F
1.75A	22μF	SUB15P01-52 x2	D2PAK	I
2.75A	44μF	SUB15P01-52 x3	D2PAK	J
3.75A	44μF	SUB15P01-52 x4	D2PAK	K

2.5V_{IN} to 1.8V_{OUT} Conversion

I _{OUT}	C _{OUT}	MOSFET	Package	Schematic
1.25A	10μF	Si4433DY	SO-8	C
2.5A	22μF	Si4433DY x2	SO-8	D
2.5A	10μF	SUB15P01-52	D2PAK	H
4.0A	44μF	Si4433DY x3	SO-8	E
5.5A	44μF	Si4433DY x4	SO-8	F
5.5A	22μF	SUB15P01-52 x2	D2PAK	I
8.0A	44μF	SUB15P01-52 x3	D2PAK	J
11.0A	44μF	SUB15P01-52 x4	D2PAK	K

2.5V_{IN} to 1.5V_{OUT} Conversion

I _{OUT}	C _{OUT}	MOSFET	Package	Schematic
1.0A	10μF	Si4433DY	SO-8	C
2.0A	22μF	Si4433DY x2	SO-8	D
2.0A	10μF	SUB15P01-52	D2PAK	H
3.0A	44μF	Si4433DY x3	SO-8	E
4.0A	44μF	Si4433DY x4	SO-8	F
4.0A	22μF	SUB15P01-52 x2	D2PAK	I
6.0A	44μF	SUB15P01-52 x3	D2PAK	J
8.0A	44μF	SUB15P01-52 x4	D2PAK	K

2.5V_{IN} to 1.25V_{OUT} Conversion

I _{OUT}	C _{OUT}	MOSFET	Package	Schematic
0.75A	10μF	Si4433DY	SO-8	C
1.5A	22μF	Si4433DY x2	SO-8	D
1.5A	10μF	SUB15P01-52	D2PAK	H
2.0A	44μF	Si4433DY x3	SO-8	E
3.0A	44μF	Si4433DY x4	SO-8	F
3.0A	22μF	SUB15P01-52 x2	D2PAK	I
4.5A	44μF	SUB15P01-52 x3	D2PAK	J
6.0A	44μF	SUB15P01-52 x4	D2PAK	K

1.8V_{IN} to 1.5V_{OUT} Conversion

I _{OUT}	C _{OUT}	MOSFET	Package	Schematic
2.0A	10μF	Si3445DV	TSOP-6	A
4.0A	22μF	Si3445DV x2	TSOP-6	B
6.0A	200μF	Si4403DY x2	SO-8	G
7.0A ⁽¹⁾	44μF	SUB15P01-52 x4	D2PAK	K

Note:

1. For space constrained designs, a DPAK equivalent can be used in this application (SUD15P01-52). This is due to R_{DS(ON)} limitation NOT power dissipation.

1.8V_{IN} to 1.25V_{OUT} Conversion

I _{OUT}	C _{OUT}	MOSFET	Package	Schematic
1.0A	10μF	Si3445DV	TSOP-6	A
1.5A	10μF	Si4433DY	SO-8	C
3.0A	22μF	Si4433DY x2	SO-8	D
3.0A	10μF	SUB15P01-52	D2PAK	H
4.5A	44μF	Si4433DY x3	SO-8	E
6.0A	44μF	Si4433DY x4	SO-8	F
6.5A	22μF	SUB15P01-52 x2	D2PAK	I
9.0A	88μF	SUB15P01-52 x3	D2PAK	J
13.0A	88μF	SUB15P01-52 x4	D2PAK	K

Schematic A

Input/Output Combination Examples

Input	Output	Maximum Current
1.8V	1.5V	2A
1.8V	1.25V	1A

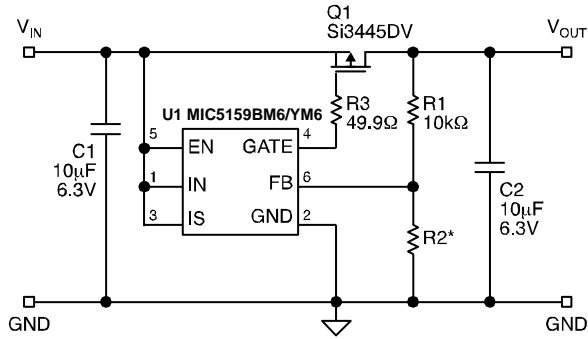

Application Circuit

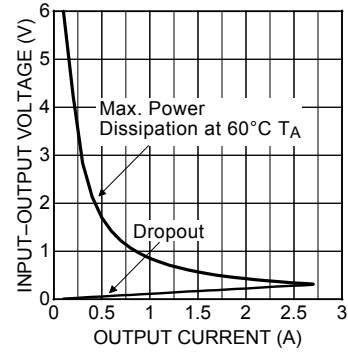

Si3445DV SOA

Bill of Materials

Item	Part Number	Manufacturer	Description	Qty.
C1	GRM40 X7R 106 6.3	Murata ⁽¹⁾	10µF, 6.3V Ceramic MLCC, Size 0805	1
C2	C2012X5RR0J106M	Murata	10µF, 6.3V Ceramic MLCC, Size 0805	1
R1	CRCW08051002	Vishay Dale ⁽²⁾	10kΩ Resistor, Size 0805	1
R2	CRCW08059761	Vishay Dale	Output Voltage:2.5V; 9.76kΩ Resistor, Size 0805 ⁽³⁾	1
	CRCW08052152	Vishay Dale	Output Voltage:1.8V; 21.5kΩ Resistor, Size 0805 ⁽³⁾	1
	CRCW08054642	Vishay Dale	Output Voltage:1.5V; 46.4kΩ Resistor, Size 0805 ⁽³⁾	1
	CRCW08058253	Vishay Dale	Output Voltage:1.25V; 825kΩ Resistor, Size 0805 ⁽³⁾	1
R3	CRCW080549R9 F	Vishay Dale	49.9Ω Resistor, Size 0805	1
Q1	Si3445DV	Vishay Siliconix ⁽⁴⁾	P-Channel MOSFET TSOP-6	1
U1	MIC5159BM6/YM6	Micrel, Inc. ⁽⁵⁾	Programmable Current Limit µCap LDO Regulator	1

Notes:

- Murata Tel: 949-916-4000
- Vishay Dale Tel: 402-563-6866
- To calculate other output voltage values:

$$R2 = \frac{R1}{\left(\frac{V_{OUT}}{1.235}\right) - 1}$$

- Vishay Siliconix Tel: 402-563-6866
- Micrel, Inc. Tel: 408-944-0800

Schematic B

Input/Output Combination Examples

Input	Output	Maximum Current
1.8V	1.5V	4A

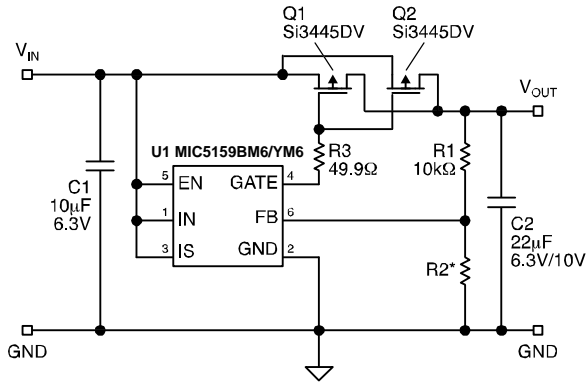

Application Circuit

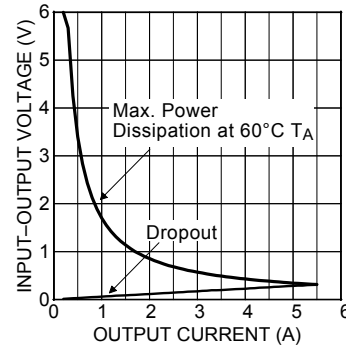

Si3445DV x2 SOA

Bill of Materials

Item	Part Number	Manufacturer	Description	Qty.
C1	GRM40 X7R 106 6.3	Murata ⁽¹⁾	10μF, 6.3V Ceramic MLCC, Size 0805	1
	C2012X5RR0J106M	TDK ⁽²⁾	10μF, 6.3V Ceramic MLCC, Size 0805	
C2	GRM42-2 X5R 226K 6.3	Murata	22μF, 6.3V Ceramic MLCC, Size 1210	1
	C2012X5RR0J106M	TDK	22μF, 10V Ceramic MLCC, Size 1210	
R1	CRCW08051002	Vishay Dale ⁽³⁾	10kΩ Resistor, Size 0805	1
R2	CRCW08059761	Vishay Dale	Output Voltage:2.5V; 9.76kΩ Resistor, Size 0805 ⁽⁴⁾	1
	CRCW08052152	Vishay Dale	Output Voltage:1.8V; 21.5kΩ Resistor, Size 0805 ⁽⁴⁾	1
	CRCW08054642	Vishay Dale	Output Voltage:1.5V; 46.4kΩ Resistor, Size 0805 ⁽⁴⁾	1
	CRCW08058253	Vishay Dale	Output Voltage:1.25V; 825kΩ Resistor, Size 0805 ⁽⁴⁾	1
R3	CRCW080549R9 F	Vishay Dale	49.9Ω Resistor, Size 0805	1
Q1, Q2	Si3445DV	Vishay Siliconix ⁽⁵⁾	P-Channel MOSFET TSOP-6	2
U1	MIC5159BM6/YM6	Micrel, Inc. ⁽⁶⁾	Programmable Current Limit μCap LDO Regulator	1

Notes:

- Murata Tel: 949-916-4000
- TDK Tel: 1-888-835-6646
- Vishay Dale Tel: 402-563-6866
- To calculate other output voltage values:

$$R2 = \frac{R1}{\left(\frac{V_{OUT}}{1.235}\right) - 1}$$

- Vishay Siliconix Tel: 402-563-6866
- Micrel, Inc. Tel: 408-944-0800

Schematic C

Input/Output Combination Examples

Input	Output	Maximum Current
3.3V	2.5V	1A
3.3V	1.8V	0.6A
3.3V	1.5V	0.5A
3.3V	1.25V	0.4A
2.5V	1.8V	1.25A
2.5V	1.5V	1A
2.5V	1.25V	0.75A
1.8V	1.25V	1.5A

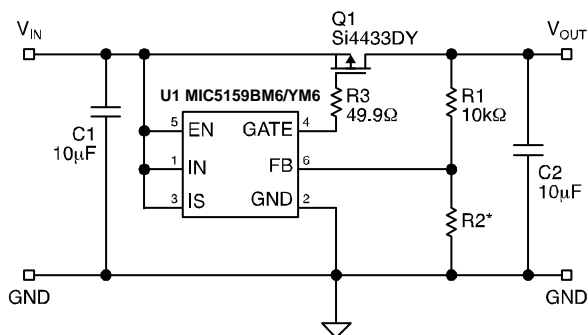

Application Circuit

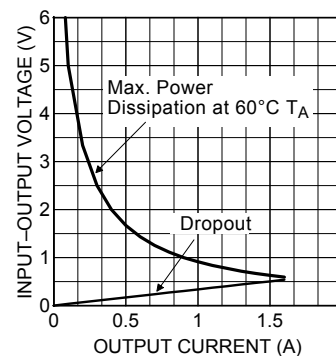

Si34433DY SOA

Bill of Materials

Item	Part Number	Manufacturer	Description	Qty.
C1	GRM40 X7R 106 6.3	Murata ⁽¹⁾	10µF, 6.3V Ceramic MLCC, Size 0805	1
C2	C2012X5RROJ106M	TDK ⁽²⁾	10µF, 6.3V Ceramic MLCC, Size 0805	1
R1	CRCW08051002	Vishay Dale ⁽³⁾	10kΩ Resistor, Size 0805	1
R2	CRCW08059761	Vishay Dale	Output Voltage:2.5V; 9.76kΩ Resistor, Size 0805 ⁽⁴⁾	1
	CRCW08052152	Vishay Dale	Output Voltage:1.8V; 21.5kΩ Resistor, Size 0805 ⁽⁴⁾	1
	CRCW08054642	Vishay Dale	Output Voltage:1.5V; 46.4kΩ Resistor, Size 0805 ⁽⁴⁾	1
	CRCW08058253	Vishay Dale	Output Voltage:1.25V; 825kΩ Resistor, Size 0805 ⁽⁴⁾	1
R3	CRCW080549R9 F	Vishay Dale	49.9Ω Resistor, Size 0805	1
Q1	Si4433DY	Vishay Siliconix ⁽⁵⁾	P-Channel MOSFET SO-8	1
U1	MIC5159BM6/YM6	Micrel, Inc. ⁽⁶⁾	Programmable Current Limit µCap LDO Regulator	1

Notes:

1. Murata Tel: 949-916-4000
2. TDK Tel: 1-888-835-6646
3. Vishay Dale Tel: 402-563-6866
4. To calculate other output voltage values:

$$R2 = \frac{R1}{\left(\frac{V_{OUT}}{1.235}\right) - 1}$$

5. Vishay Siliconix Tel: 402-563-6866
6. Micrel, Inc. Tel: 408-944-0800

Schematic D

Input/Output Combination Examples

Input	Output	Maximum Current
3.3V	2.5V	2.5A
3.3V	1.8V	1.25A
3.3V	1.5V	1A
3.3V	1.25V	0.75A
2.5V	1.8V	2.5A
2.5V	1.5V	2A
2.5V	1.25V	1.5A
1.8V	1.5V	2A
1.8V	1.25V	3A

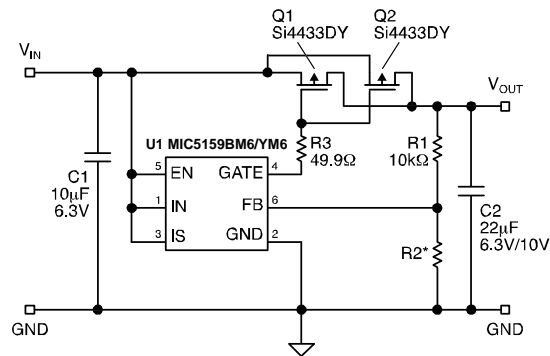

Application Circuit

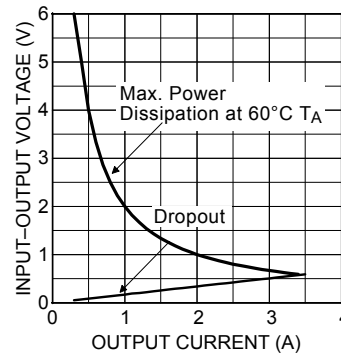

Si34433DY x2 SOA

Bill of Materials

Item	Part Number	Manufacturer	Description	Qty.
C1	GRM40 X7R 106 6.3	Murata ⁽¹⁾	10µF, 6.3V Ceramic MLCC, Size 0805	1
	C2012X5RR0J106M	TDK ⁽²⁾	10µF, 6.3V Ceramic MLCC, Size 0805	
C2	GRM42-2 X5R 226K 6.3	Murata	22µF, 6.3V Ceramic MLCC, Size 1210	1
	C3225X5R1A226M	TDK	22µF, 10V Ceramic MLCC, Size 1210	
R1	CRCW08051002	Vishay Dale ⁽³⁾	10kΩ Resistor, Size 0805	1
R2	CRCW08059761	Vishay Dale	Output Voltage:2.3V; 9.76kΩ Resistor, Size 0805 ⁽⁴⁾	1
	CRCW08052152	Vishay Dale	Output Voltage:1.8V; 21.5kΩ Resistor, Size 0805 ⁽⁴⁾	1
	CRCW08054642	Vishay Dale	Output Voltage:1.5V; 46.4kΩ Resistor, Size 0805 ⁽⁴⁾	1
	CRCW08058253	Vishay Dale	Output Voltage:1.25V; 825kΩ Resistor, Size 0805 ⁽⁴⁾	1
R3	CRCW080549R9 F	Vishay Dale	49.9Ω Resistor, Size 0805	1
Q1, Q2	Si4433DY	Vishay Siliconix ⁽⁵⁾	P-Channel MOSFET SO-8	2
U1	MIC5159BM6/YM6	Micrel, Inc. ⁽⁶⁾	Programmable Current Limit µCap LDO Regulator	1

Notes:

- Murata Tel: 949-916-4000
- TDK Tel: 1-888-835-6646
- Vishay Dale Tel: 402-563-6866
- To calculate other output voltage values:

$$R2 = \frac{R1}{\left(\frac{V_{OUT}}{1.235}\right) - 1}$$

- Vishay Siliconix Tel: 402-563-6866
- Micrel, Inc. Tel: 408-944-0800

Schematic E

Input/Output Combination Examples

Input	Output	Maximum Current
3.3V	2.5V	3.5A
3.3V	1.8V	2A
3.3V	1.5V	1.5A
3.3V	1.25V	1.25A
2.5V	1.8V	4A
2.5V	1.5V	3A
2.5V	1.25V	2A
1.8V	1.25V	4.5A

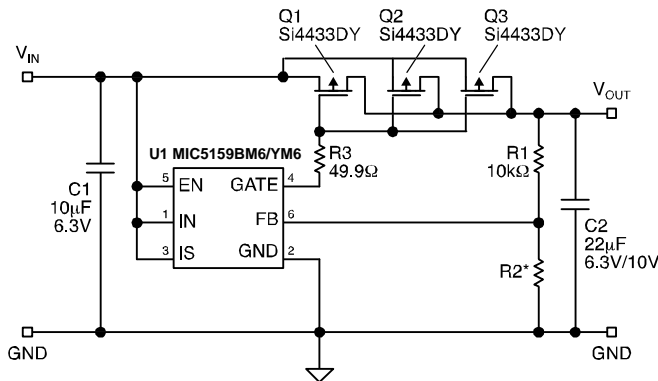

Application Circuit

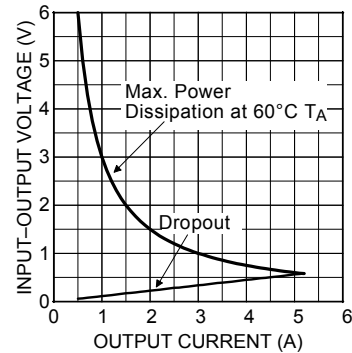

Si34433DY x3 SOA

Bill of Materials

Item	Part Number	Manufacturer	Description	Qty.
C1	GRM40 X7R 106 6.3	Murata ⁽¹⁾	10µF, 6.3V Ceramic MLCC, Size 0805	1
	C2012X5RROJ106M	TDK ⁽²⁾	10µF, 6.3V Ceramic MLCC, Size 0805	
C2	GRM42-2 X5R 226K 6.3	Murata	22µF, 6.3V Ceramic MLCC, Size 1210	1
	C3225X5R1A226M	TDK	22µF, 10V Ceramic MLCC, Size 1210	
R1	CRCW08051002	Vishay Dale ⁽³⁾	10kΩ Resistor, Size 0805	1
R2	CRCW08059761	Vishay Dale	Output Voltage:2.5V; 9.76kΩ Resistor, Size 0805 ⁽⁴⁾	1
	CRCW08052152	Vishay Dale	Output Voltage:1.8V; 21.5kΩ Resistor, Size 0805 ⁽⁴⁾	1
	CRCW08054642	Vishay Dale	Output Voltage:1.5V; 46.4kΩ Resistor, Size 0805 ⁽⁴⁾	1
	CRCW08058253	Vishay Dale	Output Voltage:1.25V; 825kΩ Resistor, Size 0805 ⁽⁴⁾	1
R3	CRCW080549R9 F	Vishay Dale	49.9Ω Resistor, Size 0805	1
Q1,Q2, Q3	Si4433DY	Vishay Siliconix ⁽⁵⁾	P-Channel MOSFET SO-8	3
U1	MIC5159BM6/YM6	Micrel, Inc. ⁽⁶⁾	Programmable Current Limit µCap LDO Regulator	1

Notes:

1. Murata Tel: 949-916-4000
2. TDK Tel: 1-888-835-6646
3. Vishay Dale Tel: 402-563-6866
4. To calculate other output voltage values:

$$R2 = \frac{R1}{\left(\frac{V_{OUT}}{1.235}\right) - 1}$$

5. Vishay Siliconix Tel: 402-563-6866
6. Micrel, Inc. Tel: 408-944-0800

Schematic F

Input/Output Combination Examples

Input	Output	Maximum Current
3.3V	2.5V	5A
3.3V	1.8V	2.5A
3.3V	1.5V	2A
3.3V	1.25V	1.75A
2.5V	1.8V	5.5A
2.5V	1.5V	4A
2.5V	1.25V	3A
1.8V	1.25V	6.5A

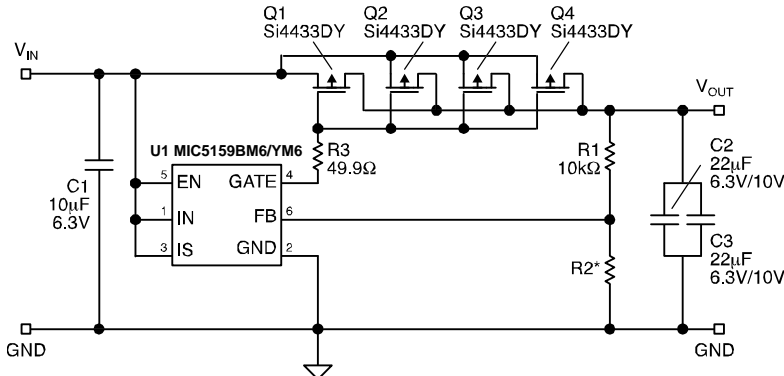

Application Circuit

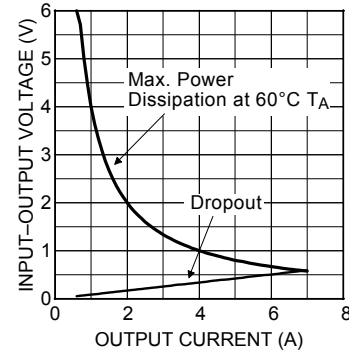

Si34433DY x4 SOA

Bill of Materials

Item	Part Number	Manufacturer	Description	Qty.
C1	GRM40 X7R 106 6.3	Murata ⁽¹⁾	10µF, 6.3V Ceramic MLCC, Size 0805	1
	C2012X5RROJ106M	TDK ⁽²⁾	10µF, 6.3V Ceramic MLCC, Size 0805	
C2	GRM42-2 X5R 226K 6.3	Murata	22µF, 6.3V Ceramic MLCC, Size 1210	1
	C3225X5R1A226M	TDK	22µF, 10V Ceramic MLCC, Size 1210	
R1	CRCW08051002	Vishay Dale ⁽³⁾	10kΩ Resistor, Size 0805	1
R2	CRCW08059761	Vishay Dale	Output Voltage:2.5V; 9.76kΩ Resistor, Size 0805(4)	1
	CRCW08052152	Vishay Dale	Output Voltage:1.8V; 21.5kΩ Resistor, Size 0805(4)	1
	CRCW08054642	Vishay Dale	Output Voltage:1.5V; 46.4kΩ Resistor, Size 0805(4)	1
	CRCW08058253	Vishay Dale	Output Voltage:1.25V; 825kΩ Resistor, Size 0805(4)	1
R3	CRCW080549R9 F	Vishay Dale	49.9Ω Resistor, Size 0805	1
Q1,Q2, Q3,Q4	Si4433DY	Vishay Siliconix ⁽⁵⁾	P-Channel MOSFET SO-8	4
U1	MIC5159BM6/YM6	Micrel, Inc. ⁽⁶⁾	Programmable Current Limit µCap LDO Regulator	1

Notes:

1. Murata Tel: 949-916-4000
2. TDK Tel: 1-888-835-6646
3. Vishay Dale Tel: 402-563-6866
4. To calculate other output voltage values:

$$R2 = \frac{R1}{\left(\frac{V_{OUT}}{1.235}\right) - 1}$$

5. Vishay Siliconix Tel: 402-563-6866
6. Micrel, Inc. Tel: 408-944-0800

Schematic G

Input/Output Combination Examples

Input	Output	Maximum Current
1.8V	1.5V	6A

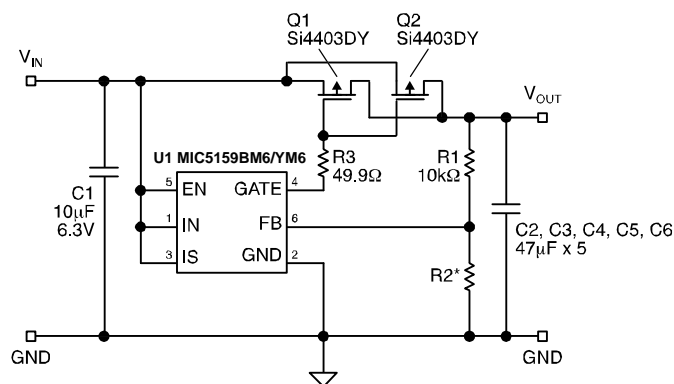

Application Circuit

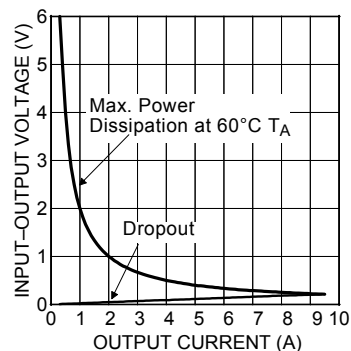

Si34403DY x2 SOA

Bill of Materials

Item	Part Number	Manufacturer	Description	Qty.
C1	GRM40 X7R 106 6.3	Murata ⁽¹⁾	10µF, 6.3V Ceramic MLCC, Size 0805	1
	C2012X5RR0J106M	TDK ⁽²⁾	10µF, 6.3V Ceramic MLCC, Size 0805	
C2,C3 C4,C5,C6	GRM43 ER60J476K	Murata	47µF, 6.3V Ceramic MLCC, Size 1812	1
	C4532X5R0J476M	TDK	47µF, 6.3V Ceramic MLCC, Size 1812	
R1	CRCW08051002	Vishay Dale ⁽³⁾	10kΩ Resistor, Size 0805	1
R2	CRCW08059761	Vishay Dale	Output Voltage:2.5V; 9.76kΩ Resistor, Size 0805 ⁽⁴⁾	1
	CRCW08052152	Vishay Dale	Output Voltage:1.8V; 21.5kΩ Resistor, Size 0805 ⁽⁴⁾	1
	CRCW08054642	Vishay Dale	Output Voltage:1.5V; 46.4kΩ Resistor, Size 0805 ⁽⁴⁾	1
	CRCW08058253	Vishay Dale	Output Voltage:1.25V; 825kΩ Resistor, Size 0805 ⁽⁴⁾	1
R3	CRCW080549R9 F	Vishay Dale	49.9Ω Resistor, Size 0805	1
Q1,Q2	Si4403DY	Vishay Siliconix ⁽⁵⁾	P-Channel MOSFET SO-8	2
U1	MIC5159BM6/YM6	Micrel, Inc. ⁽⁶⁾	Programmable Current Limit µCap LDO Regulator	1

Notes:

- Murata Tel: 949-916-4000
- TDK Tel: 1-888-835-6646
- Vishay Dale Tel: 402-563-6866
- To calculate other output voltage values:

$$R2 = \frac{R1}{\left(\frac{V_{OUT}}{1.235}\right) - 1}$$

- Vishay Siliconix Tel: 402-563-6866
- Micrel, Inc. Tel: 408-944-0800

Schematic H

Input/Output Combination Examples

Input	Output	Maximum Current
3.3V	2.5V	2.5A
3.3V	1.8V	1.25A
3.3V	1.5V	1A
3.3V	1.25V	0.75A
2.5V	1.8V	2.5A
2.5V	1.5V	2A
2.5V	1.25V	1.5A
1.8V	1.25V	3A

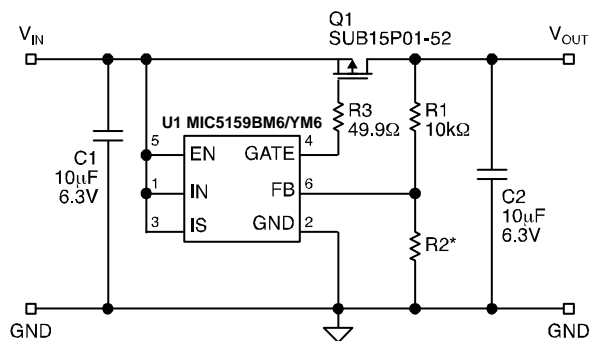

Application Circuit

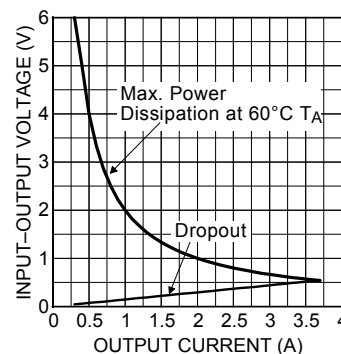

SUB15P01-52 SOA

Bill of Materials

Item	Part Number	Manufacturer	Description	Qty.
C1	GRM40 X7R 106 6.3	Murata ⁽¹⁾	10µF, 6.3V Ceramic MLCC, Size 0805	1
C2	C2012X5RR0J106M	TDK ⁽²⁾	10µF, 6.3V Ceramic MLCC, Size 0805	1
R1	CRCW08051002	Vishay Dale ⁽³⁾	10kΩ Resistor, Size 0805	1
R2	CRCW08059761	Vishay Dale	Output Voltage:2.5V; 9.76kΩ Resistor, Size 0805 ⁽⁴⁾	1
	CRCW08052152	Vishay Dale	Output Voltage:1.8V; 21.5kΩ Resistor, Size 0805 ⁽⁴⁾	1
	CRCW08054642	Vishay Dale	Output Voltage:1.5V; 46.4kΩ Resistor, Size 0805 ⁽⁴⁾	1
	CRCW08058253	Vishay Dale	Output Voltage:1.25V; 825kΩ Resistor, Size 0805 ⁽⁴⁾	1
R3	CRCW080549R9 F	Vishay Dale	49.9Ω Resistor, Size 0805	1
Q1	SUB15P01-52	Vishay Siliconix ⁽⁵⁾	P-Channel MOSFET TO-263	1
U1	MIC5159BM6/YM6	Micrel, Inc. ⁽⁶⁾	Programmable Current Limit µCap LDO Regulator	1

Notes:

1. Murata Tel: 949-916-4000
2. TDK Tel: 1-888-835-6646
3. Vishay Dale Tel: 402-563-6866
4. To calculate other output voltage values:

$$R2 = \frac{R1}{\left(\frac{V_{OUT}}{1.235}\right) - 1}$$

5. Vishay Siliconix Tel: 402-563-6866
6. Micrel, Inc. Tel: 408-944-0800

Schematic I

Input/Output Combination Examples

Input	Output	Maximum Current
3.3V	2.5V	5A
3.3V	1.8V	2.5A
3.3V	1.5V	2A
3.3V	1.25V	1.75A
2.5V	1.8V	5.5A
2.5V	1.5V	4A
2.5V	1.25V	3A
1.8V	1.25V	6.5A

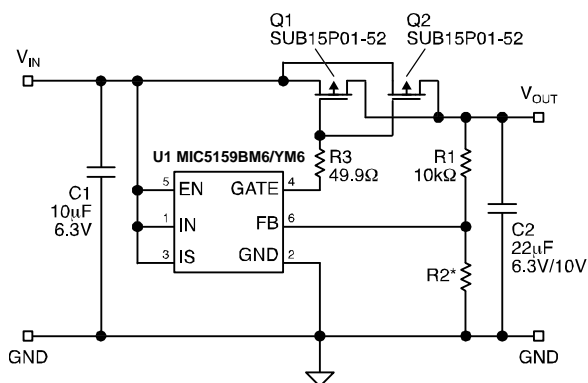

Application Circuit

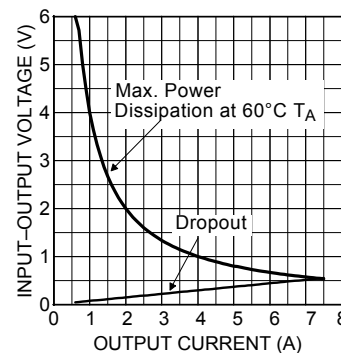

SUB15P01-52 x2 SOA

Bill of Materials

Item	Part Number	Manufacturer	Description	Qty.
C1	GRM40 X7R 106 6.3	Murata ⁽¹⁾	10µF, 6.3V Ceramic MLCC, Size 0805	1
	C2012X5RR0J106M	TDK ⁽²⁾	10µF, 6.3V Ceramic MLCC, Size 0805	
C2	GRM42-2 X5R 226K 6.3	Murata	22µF, 6.3V Ceramic MLCC, Size 1210	1
	C3225X5R1A226M	TDK	22µF, 10V Ceramic MLCC, Size 1210	
R1	CRCW08051002	Vishay Dale ⁽³⁾	10kΩ Resistor, Size 0805	1
R2	CRCW08059761	Vishay Dale	Output Voltage:2.5V; 9.76kΩ Resistor, Size 0805 ⁽⁴⁾	1
	CRCW08052152	Vishay Dale	Output Voltage:1.8V; 21.5kΩ Resistor, Size 0805 ⁽⁴⁾	1
	CRCW08054642	Vishay Dale	Output Voltage:1.5V; 46.4kΩ Resistor, Size 0805 ⁽⁴⁾	1
	CRCW08058253	Vishay Dale	Output Voltage:1.25V; 825kΩ Resistor, Size 0805 ⁽⁴⁾	1
R3	CRCW080549R9 F	Vishay Dale	49.9Ω Resistor, Size 0805	1
Q1,Q2	SUB15P01-52	Vishay Siliconix ⁽⁵⁾	P-Channel MOSFET TO-263	2
U1	MIC5159BM6/YM6	Micrel, Inc. ⁽⁶⁾	Programmable Current Limit µCap LDO Regulator	1

Notes:

- Murata Tel: 949-916-4000
- TDK Tel: 1-888-835-6646
- Vishay Dale Tel: 402-563-6866
- To calculate other output voltage values:

$$R2 = \frac{R1}{\left(\frac{V_{OUT}}{1.235}\right) - 1}$$

- Vishay Siliconix Tel: 402-563-6866
- Micrel, Inc. Tel: 408-944-0800

Schematic J

Input/Output Combination Examples

Input	Output	Maximum Current
3.3V	2.5V	7.5A
3.3V	1.8V	3.75A
3.3V	1.5V	3A
3.3V	1.25V	2.75A
2.5V	1.8V	8A
2.5V	1.5V	6A
2.5V	1.25V	4.5A
1.8V	1.25V	9.5A

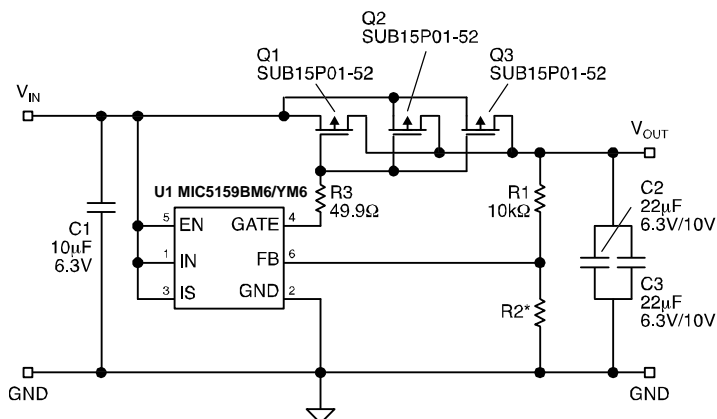

Application Circuit

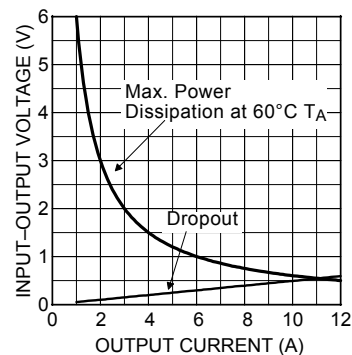

SUB15P01-52 x3 SOA

Bill of Materials

Item	Part Number	Manufacturer	Description	Qty.
C1	GRM40 X7R 106 6.3	Murata ⁽¹⁾	10µF, 6.3V Ceramic MLCC, Size 0805	1
	C2012X5RR0J106M	TDK ⁽²⁾	10µF, 6.3V Ceramic MLCC, Size 0805	
C2, C3	GRM42-2 X5R 226K 6.3	Murata	22µF, 6.3V Ceramic MLCC, Size 1210	1
	C3225X5R1A226M	TDK	22µF, 10V Ceramic MLCC, Size 1210	
R1	CRCW08051002	Vishay Dale ⁽³⁾	10kΩ Resistor, Size 0805	1
R2	CRCW08059761	Vishay Dale	Output Voltage:2.5V; 9.76kΩ Resistor, Size 0805 ⁽⁴⁾	1
	CRCW08052152	Vishay Dale	Output Voltage:1.8V; 21.5kΩ Resistor, Size 0805 ⁽⁴⁾	1
	CRCW08054642	Vishay Dale	Output Voltage:1.5V; 46.4kΩ Resistor, Size 0805 ⁽⁴⁾	1
	CRCW08058253	Vishay Dale	Output Voltage:1.25V; 825kΩ Resistor, Size 0805 ⁽⁴⁾	1
R3	CRCW080549R9 F	Vishay Dale	49.9Ω Resistor, Size 0805	1
Q1,Q2 Q3	SUB15P01-52	Vishay Siliconix ⁽⁵⁾	P-Channel MOSFET TO-263	3
U1	MIC5159BM6/YM6	Micrel, Inc. ⁽⁶⁾	Programmable Current Limit µCap LDO Regulator	1

Notes:

1. Murata Tel: 949-916-4000
2. TDK Tel: 1-888-835-6646
3. Vishay Dale Tel: 402-563-6866
4. To calculate other output voltage values:

$$R2 = \frac{R1}{\left(\frac{V_{OUT}}{1.235}\right) - 1}$$

5. Vishay Siliconix Tel: 402-563-6866
6. Micrel, Inc. Tel: 408-944-0800

Schematic K

Input/Output Combination Examples

Input	Output	Maximum Current
3.3V	2.5V	10A
3.3V	1.8V	5A
3.3V	1.5V	4.25A
3.3V	1.25V	3.75A
2.5V	1.8V	11A
2.5V	1.5V	8A
2.5V	1.25V	6A
1.8V	1.5V	7A
1.8V	1.25V	13A

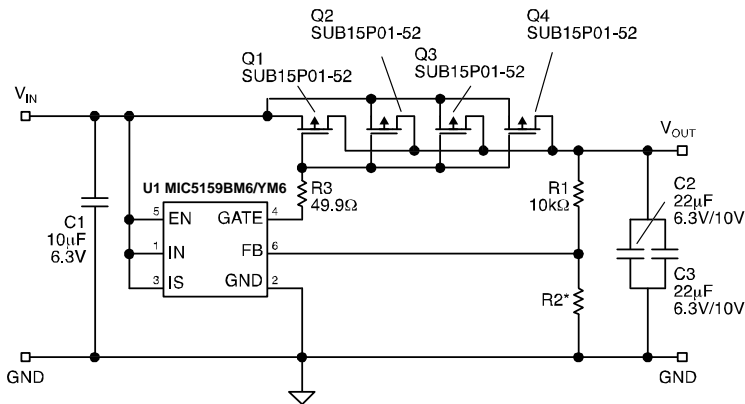

Application Circuit

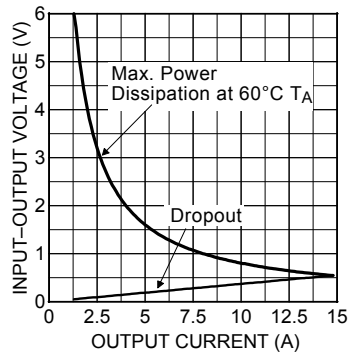

SUB15P01-52 x4 SOA

Bill of Materials

Item	Part Number	Manufacturer	Description	Qty.
C1	GRM40 X7R 106 6.3	Murata ⁽¹⁾	10µF, 6.3V Ceramic MLCC, Size 0805	1
	C2012X5RR0J106M	TDK ⁽²⁾	10µF, 6.3V Ceramic MLCC, Size 0805	
C2, C3	GRM42-2 X5R 226K 6.3	Murata	22µF, 6.3V Ceramic MLCC, Size 1210	2
	C3225X5R1A226M	TDK	22µF, 10V Ceramic MLCC, Size 1210	
R1	CRCW08051002	Vishay Dale ⁽³⁾	10kΩ Resistor, Size 0805	1
R2	CRCW08059761	Vishay Dale	Output Voltage:2.5V; 9.76kΩ Resistor, Size 0805 ⁽⁴⁾	1
	CRCW08052152	Vishay Dale	Output Voltage:1.8V; 21.5kΩ Resistor, Size 0805 ⁽⁴⁾	1
	CRCW08054642	Vishay Dale	Output Voltage:1.5V; 46.4kΩ Resistor, Size 0805 ⁽⁴⁾	1
	CRCW08058253	Vishay Dale	Output Voltage:1.25V; 825kΩ Resistor, Size 0805 ⁽⁴⁾	1
R3	CRCW080549R9 F	Vishay Dale	49.9Ω Resistor, Size 0805	1
Q1, Q2 Q3, Q4	SUB15P01-52	Vishay Siliconix ⁽⁵⁾	P-Channel MOSFET TO-263	4
U1	MIC5159BM6/YM6	Micrel, Inc. ⁽⁶⁾	Programmable Current Limit µCap LDO Regulator	1

Notes:

- Murata Tel: 949-916-4000
- TDK Tel: 1-888-835-6646
- Vishay Dale Tel: 402-563-6866
- To calculate other output voltage values:

$$R2 = \frac{R1}{\left(\frac{V_{OUT}}{1.235}\right) - 1}$$

- Vishay Siliconix Tel: 402-563-6866
- Micrel, Inc. Tel: 408-944-0800

Package Information

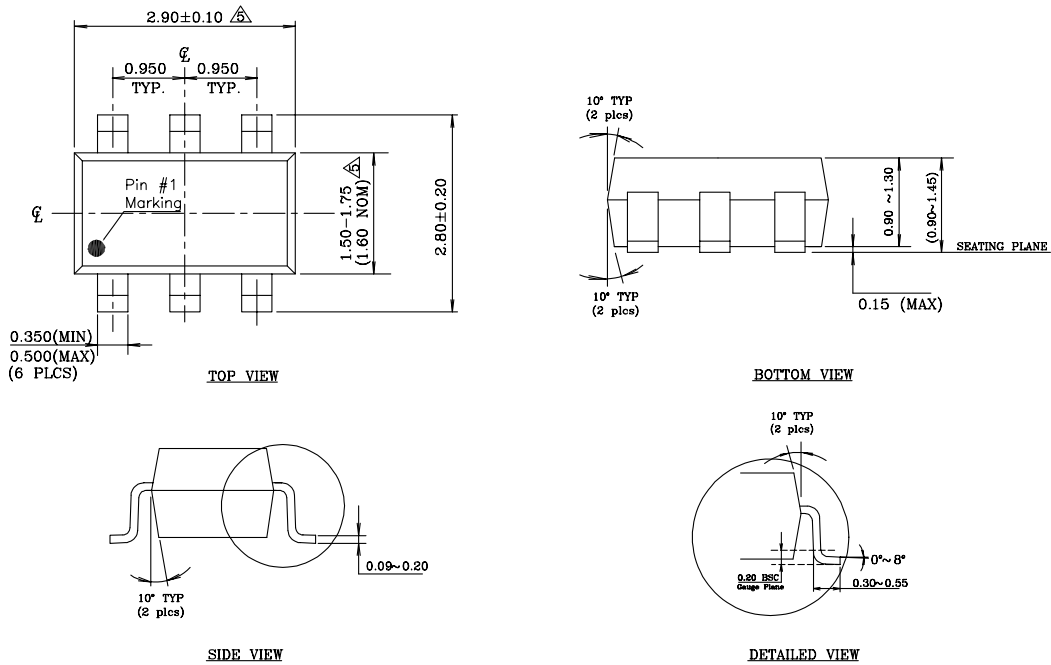

NOTE:

1. Dimensions and tolerances are as per ANSI Y14.5M, 1982.
 2. Package surface to be mirror finish.
 3. Die is facing up for mold. Die is facing down for trim/form, ie. reverse trim/form.
 4. The footlength measuring is based on the gauge plane method.
- △ Dimension are exclusive of mold flash & gate burr.

6-Pin SOT-23 (M6)

MICREL, INC. 2180 FORTUNE DRIVE SAN JOSE, CA 95131 USA
 TEL +1 (408) 944-0800 FAX +1 (408) 474-1000 WEB <http://www.micrel.com>

The information furnished by Micrel in this data sheet is believed to be accurate and reliable. However, no responsibility is assumed by Micrel for its use. Micrel reserves the right to change circuitry and specifications at any time without notification to the customer.

Micrel Products are not designed or authorized for use as components in life support appliances, devices or systems where malfunction of a product can reasonably be expected to result in personal injury. Life support devices or systems are devices or systems that (a) are intended for surgical implant into the body or (b) support or sustain life, and whose failure to perform can be reasonably expected to result in a significant injury to the user. A Purchaser's use or sale of Micrel Products for use in life support appliances, devices or systems is a Purchaser's own risk and Purchaser agrees to fully indemnify Micrel for any damages resulting from such use or sale.

© 2004 Micrel, Incorporated.